



PJM

Emergency Procedures

LCC / MOC / OPS 101

- Know where to find a copy of the procedures
 - PJM Manual References
 - M-13 - Emergency Operations
 - M-12 - Dispatching Operations
 - M-03 - Transmission Operations
- Have a good understanding and working knowledge of the procedures
- Know your responsibilities

- To help MOC/LCC Dispatchers understand:
 - The types of Emergencies encountered by PJM
 - The actions required to alleviate the emergency conditions.
 - The information and reports required by PJM

Capacity Shortages

Objectives:

- Understand the severity of Emergency Procedures
- Summarize condition of system (SSR)
- Implement appropriate responses

PJM Manual M-13 - Page 2-4

“The PJM OI dispatcher has the flexibility of implementing the emergency procedures in whatever order is required to ensure overall system reliability. The PJM OI dispatcher has the flexibility to exit the emergency procedures in a different order than they are implemented when conditions necessitate.”

- Each procedure related to one side of the scale or the other: Maximizing supply/Minimizing demand
- Categories
 - Alerts
 - Warnings
 - Actions

- Documentation found in Appendix 9B of NERC Operating Manual
- Issued by Security Coordinator (via the Security Coordinators Information System - SCIS) for capacity and energy shortages
- Three Levels
 - Provides common terminology for Security Coordinators to use when explaining energy emergencies to each other
 - Levels may be declared in whatever order necessary, not need to proceed sequentially

- **Alert Level 1**
 - Issued when a Control Area “foresees or is experiencing conditions where all available resources are committed”
- When does PJM issue??
 - Max Emergency Generation Alert

- **Alert Level 2**
 - Issued when a Control Area “foresees or has implemented procedures up to but excluding interruption of firm load commitments”
 - Public Appeals, Voltage Reduction, Load Management
- **When does PJM issue?**
 - Voltage Reduction Alert

- **Alert Level 3**
 - Issued when a Control Area “foresees or has implemented firm load obligation interruption”
 - Prior to declaring:
 - All generation on-line, regardless of cost
 - All purchases made, regardless of cost
 - All non-firm sales recalled
 - All contractually interruptible load curtailed
- **When does PJM issue?**
 - Manual Load Dump Warning

- Alerts are issued in advance of the period to allow members to prepare
- Four Alerts (for Capacity Shortages)
 - Maximum Emergency Generation Alert
 - Primary Reserve Alert
 - Voltage Reduction Alert
 - Voluntary Customer Load Curtailment Alert

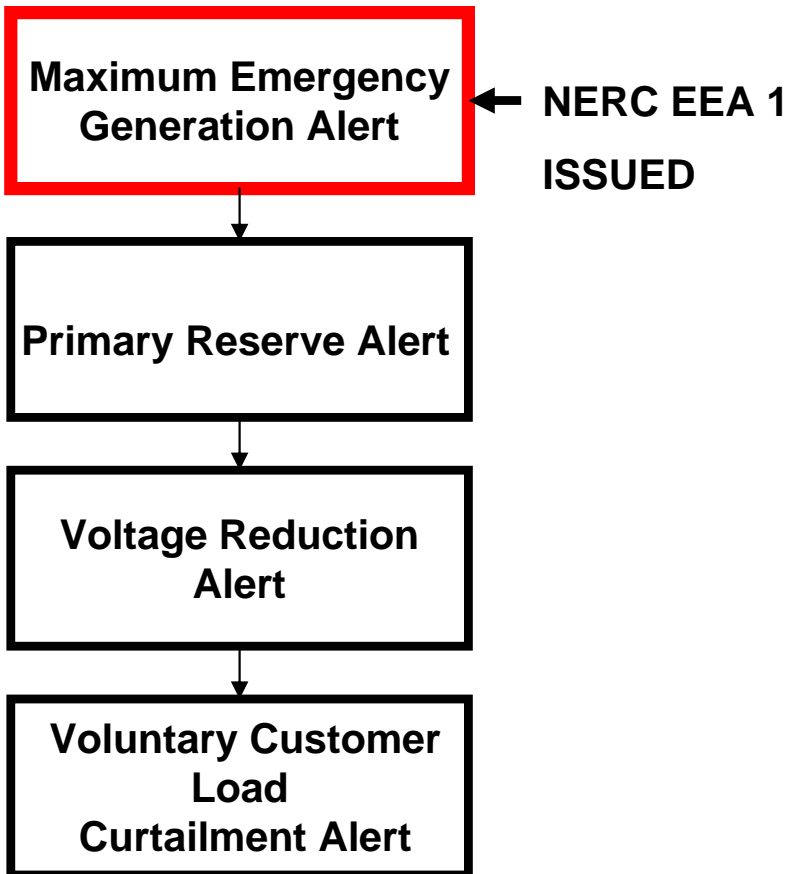

Maximum Emergency Generation Alert

- Purpose
 - To provide an early alert that PJM Emergency Procedures may be required
- Trigger
 - When Maximum Emergency Generation is called into the operating capacity
 - Operating Reserve Requirement is greater than scheduled Operating Reserve.

EEA(Energy Emergency Alert)

Load and Capacity Profile

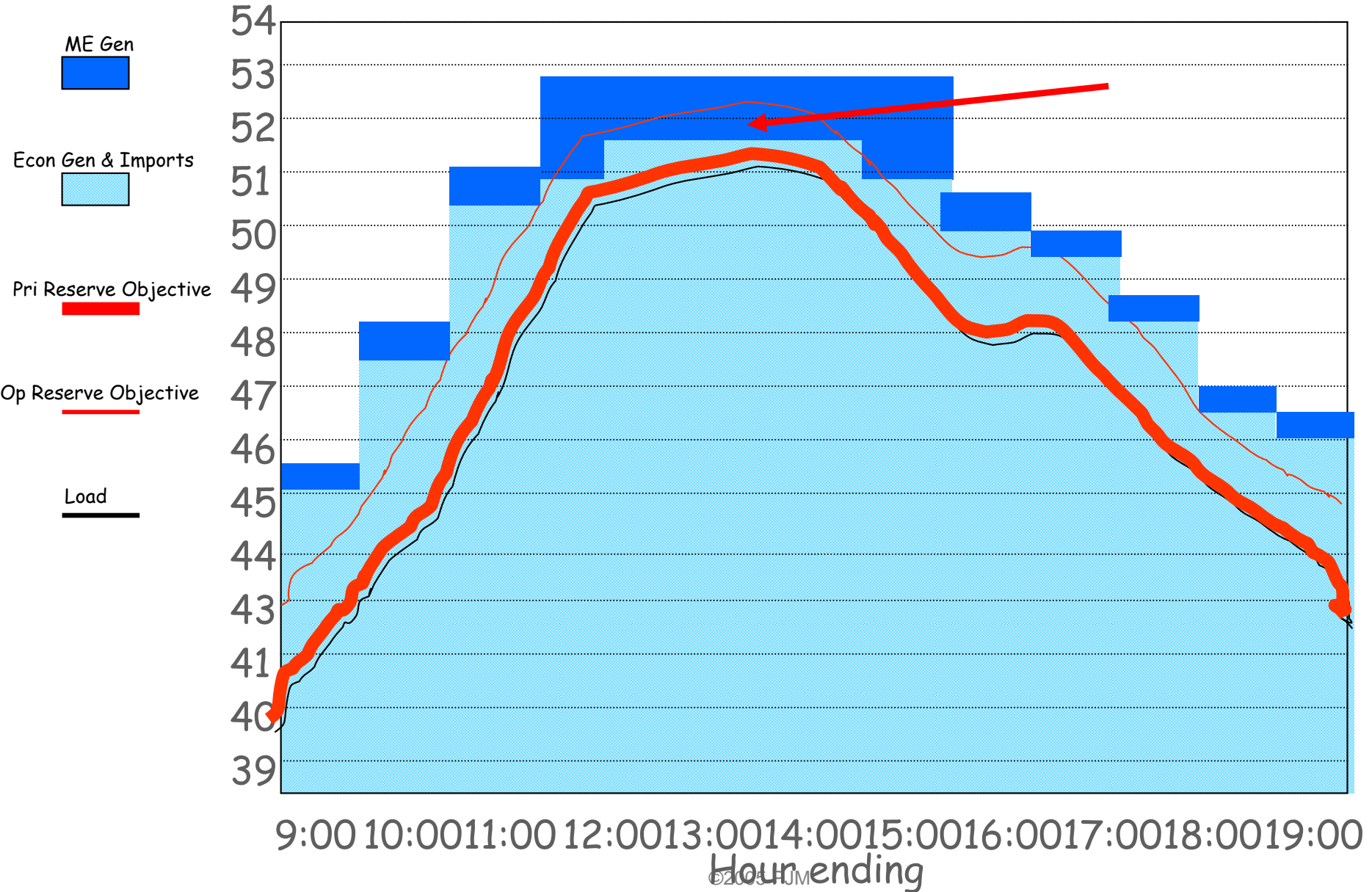

Maximum Emergency Generation Alert

- PJM Actions
 - Notifications
 - Internal / External
 - Set up SSR
- Member Actions
 - Notifications
 - Internal / External
 - Key Station Personnel
 - Suspend any high risk testing of generating or transmission equipment

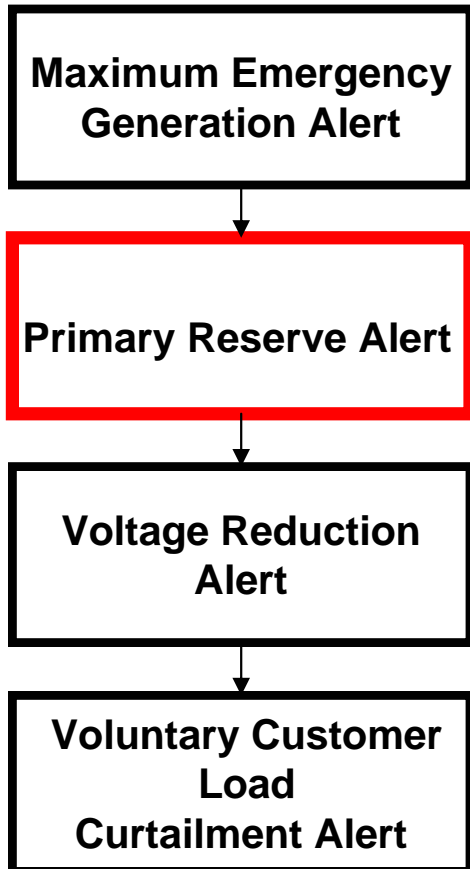

Primary Reserve Alert

- Purpose
 - To alert Local Control Centers of an anticipated shortage of operating reserve capacity in a future critical period
- Trigger
 - When the estimated operating reserve is less than the forecasted primary reserve requirement

Primary Reserve Alert

- PJM Actions
 - Notifications
 - Internal / External
- Member Actions
 - Notifications
 - Internal / External
 - Key Station Personnel
 - Defer any scheduled maintenance

Load and Capacity Profile

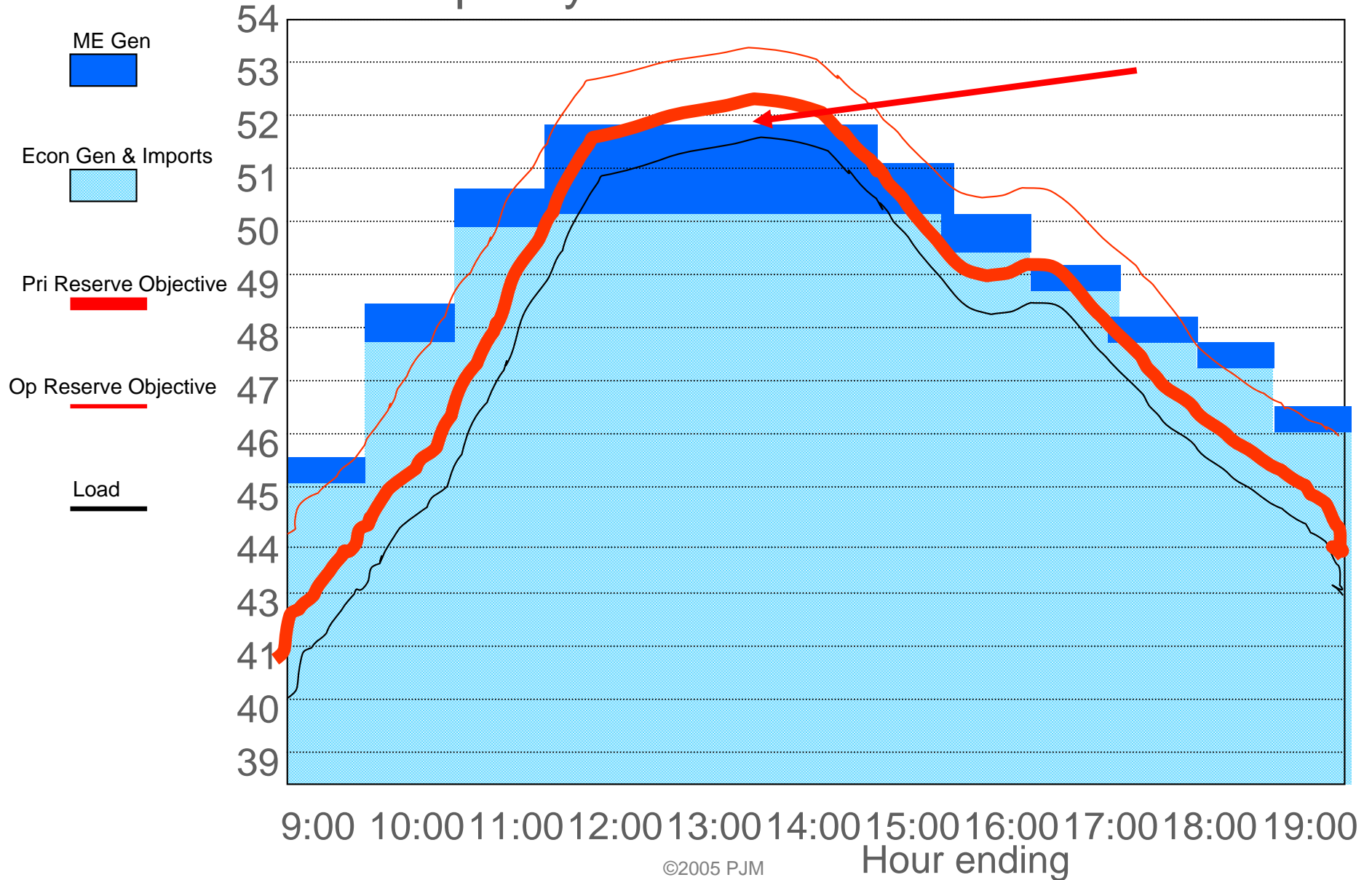

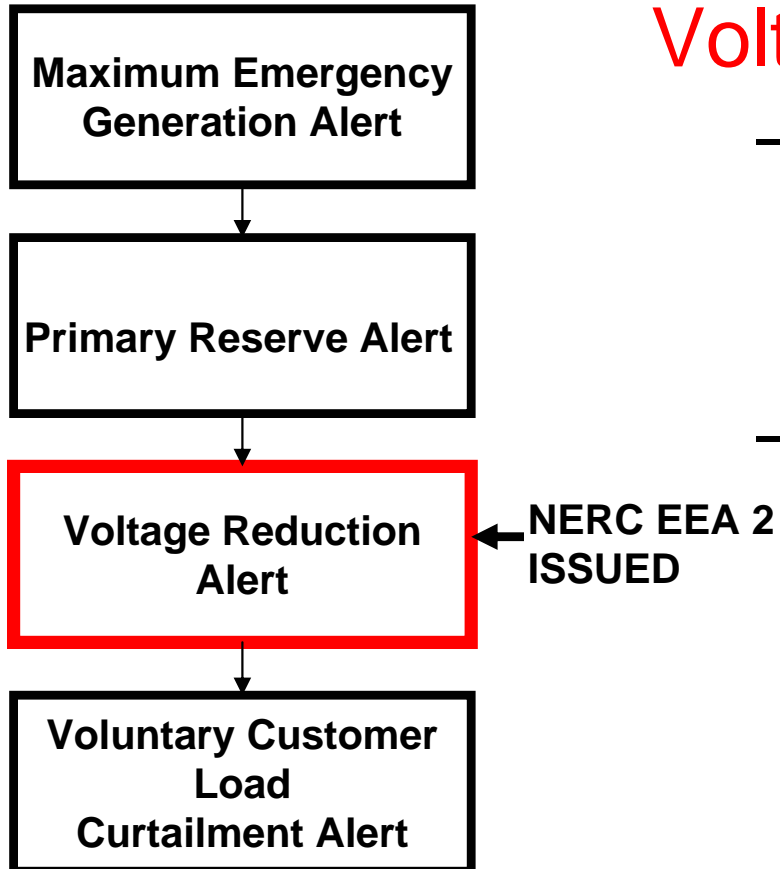

Voltage Reduction Alert

– Purpose

- To alert Members that a Voltage Reduction may be required in a future critical period

– Trigger

- When the estimated operating reserve is less than the forecasted spinning reserve requirement

Voltage Reduction Alert

- PJM Actions
 - Notifications
 - Internal / External
 - Give LCC's estimated hour of implementation
- Member Actions
 - Notifications
 - Internal / External
 - Key Station Personnel
 - Take any necessary steps to expedite implementation of voltage reduction, should one become necessary

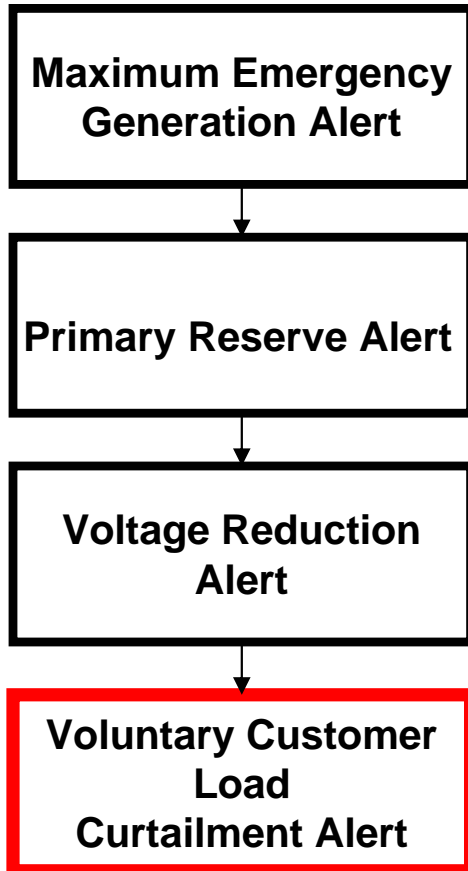

Voluntary Customer Load Curtailment Alert

- Purpose
 - Alert Local Control Centers of a probable future need to implement a VCLC
- Trigger
 - Estimated operating reserve capacity indicates a need for curtailing customer load

Voluntary Customer Load Curtailment Alert

- PJM Actions
 - Notifications
 - Internal / External
 - Give LCC's estimated hour of implementation
- Member Actions
 - Notifications
 - Internal / External
 - Key Station Personnel
 - Take any necessary steps to expedite implementation of VCLC, should it become necessary



Attachment A: Supplementary Status Report							
PJM SUPPLEMENTARY STATUS REPORT							
INFORMATION FOR:				(CONTROL CENTER NAME)			
Date: ____/____/____				Time: ____:____			
Completed By:				Phone #:			
Values are to be completed for the <i>time requested</i> by the PJM OI Dispatcher							
PART A: Instantaneous Capacity Check							
NOTE: Only generation that is synchronized, Hydro and CTs less than 10 minutes, and applicable Resource limited units reported in Part G should be included in this section.							
		Nuclear		Fossil		Hydro	CT/Diesel
On Cost Capacity	A		C		E		F
Maximum Emergency Capacity	B		D				G
PART B: Energy Loaded							
		Nuclear		Fossil		Hydro	CT/Diesel
PART C: Load Management and Inter./Curtail Customers				PART D: Voluntary Customer Load Curtailment			
PJM OI Step 1 Time < 1 Hour	H			MW Avail to Curtail	N		
PJM OI Step 2 Time > 1 Hour	I			Minimum Notification Time	O		
LCC Step 3 Time < 1 Hour	J			Time to Curtail ALL Load	P		
LCC Step 4 Time > 1 Hour	K						
Time to Implement Steps 2 & 4	L						
Total MW Interrupted so far	M						
OI Phone Number: 610-666-8810				OI Fax Number: 610-666-4287			

Exhibit A.1: Supplementary Status Report Information Reported by PJM Members - Page 1

Why??

- Used by PJM to perform capacity, load, and reserve projection when there exists potential of a bulk power emergency.
- Instantaneous “snapshot”
 - Generating capacity
 - Load management
 - Fuel limitations

**Manual Reference for
SSR:**

**M-13, Emergency Operations
Manual**

Attachment A



PJM SUPPLEMENTARY STATUS REPORT		(CONTROL CENTER NAME)					
INFORMATION FOR:							
Date: ____/____/____	Time: ____:____						
Completed By:	Phone #:						
Values are to be completed for the <i>time requested</i> by the PJM OI Dispatcher							
PART A: Instantaneous Capacity Check							
<small>NOTE: Only generation that is synchronized, Hydro and CTs less than 10 minutes, and applicable Resource limited units reported in Part G should be included in this section.</small>							
		Nuclear	Fossil	Hydro	CT/Diesel		
On Cost Capacity	A	C	E	F			
Maximum Emergency Capacity	B	D			G		
PART B: Energy Loaded							
		Nuclear	Fossil	Hydro	CT/Diesel		
PART C: Load Management and Inter./Curtail. Customers		PART D: Voluntary Customer Load Curtailment					
PJM OI Step 1 Time < 1 Hour	H	MW Avail to Curtail			N		
PJM OI Step 2 Time > 1 Hour	I	Minimum Notification Time			O		
LCC Step 3 Time < 1 Hour	J	Time to Curtail ALL Load			P		
LCC Step 4 Time > 1 Hour	K						
Time to Implement Steps 2 & 4	L						
Total MW Interrupted so far	M						
OI Phone Number: 610-666-8810		OI Fax Number: 610-666-4287					

Part A

Instantaneous Capacity Check

- Four types of generation
- Two categories
- Only generation that is synchronized
- Exception: Quick Start Hydro and CT's



PJM SUPPLEMENTARY STATUS REPORT							
INFORMATION FOR:				(CONTROL CENTER NAME)			
Date: ____/____/____				Time: ____:____			
Completed By:				Phone #:			
Values are to be completed for the <i>time requested</i> by the PJM OI Dispatcher							
PART A: Instantaneous Capacity Check							
<small>NOTE: Only generation that is synchronized, Hydro and CTs less than 10 minutes, and applicable Resource limited units reported in Part G should be included in this section.</small>							
On Cost Capacity	A	Nuclear	C	Fossil	E	Hydro	F
Maximum Emergency Capacity	B		D				G
PART B: Energy Loaded							
		Nuclear		Fossil		Hydro	CT/Diesel
PART C: Load Management and Inter./Curtail. Customers				PART D: Voluntary Customer Load Curtailment			
PJM OI Step 1 Time < 1 Hour	H			MW Avail to Curtail	N		
PJM OI Step 2 Time > 1 Hour	I			Minimum Notification Time	O		
LCC Step 3 Time < 1 Hour	J			Time to Curtail ALL Load	P		
LCC Step 4 Time > 1 Hour	K						
Time to Implement Steps 2 & 4	L						
Total MW Interrupted so far	M						
OI Phone Number: 610-666-8810				OI Fax Number: 610-666-4287			

Part B

Energy Loaded

- Output of generation
- Broken down by type
- AT TIME of SSR



PJM SUPPLEMENTARY STATUS REPORT		(LOCAL CONTROL CENTER NAME)						
Date: ____/____/____		Time: ____:____						
Completed By:		Phone #:						
Values are to be completed for the <i>time requested</i> by the PJM OI Dispatcher								
PART A: Instantaneous Capacity Check								
NOTE: Only generation that is synchronized, Hydro and CTs less than 10 minutes, and applicable Resource limited units reported in Part G should be included in this section.								
On Cost Capacity	A	Nuclear	D	Fossil	G	Hydro	H	CT/Diesel
Maximum Emergency Capacity	C		F				J	
PART B: Energy Loaded								
		Nuclear		Fossil		Hydro		CT/Diesel
PART C: Load Management and Inter./Curtail. Customers				PART D: Voluntary Customer Load Curtailment				
PJM OI Step 1 Time < 1 Hour	K			MW Avail to Curtail		O		
PJM OI Step 2 Time > 1 Hour	L			Minimum Notification Time		R		
LCC Step 3 Time < 1 Hour	M			Time to Curtail ALL Load		S		
LCC Step 4 Time > 1 Hour	N							
Time to Implement Steps 2 & 4	O							
Total MW Interrupted so far	P							
OI Phone Number: 610-666-8810				OI Fax Number: 610-666-4287				
Reported by Transmission LCC								

Part C

Load Management and Interruptible Curtailable Customers

Steps 1 & 2

PJM Controlled

Steps 3 & 4

LCC Controlled

Steps 1 & 3

< 1 Hour

Step 2 & 4

> 1 Hour



PJM SUPPLEMENTARY STATUS REPORT		(LOCAL CONTROL CENTER NAME)						
INFORMATION FOR:								
Date: ____/____/____	Time: ____:____							
Completed By:	Phone #:							
Values are to be completed for the <i>time requested</i> by the PJM OI Dispatcher								
PART A: Instantaneous Capacity Check								
NOTE: Only generation that is synchronized, Hydro and CTs less than 10 minutes, and applicable Resource limited units reported in Part G should be included in this section.								
On Cost Capacity	A	Nuclear	D	Fossil	G	Hydro	H	CT/Diesel
Maximum Emergency Capacity	C		F				J	
PART B: Energy Loaded								
		Nuclear		Fossil		Hydro		CT/Diesel
PART C: Load Management and Inter./Curtail. Customers				PART D: Voluntary Customer Load Curtailment				
PJM OI Step 1 Time < 1 Hour	K	MW Avail to Curtail			Q			
PJM OI Step 2 Time > 1 Hour	L	Minimum Notification Time			R			
LCC Step 3 Time < 1 Hour	M	Time to Curtail ALL Load			S			
LCC Step 4 Time > 1 Hour	N							
Time to Implement Steps 2 & 4	O							
Total MW Interrupted so far	P							
Reported by Transmission LCC								

Part D

Voluntary Customer Load Curtailment (VCLC)

- Report total amount of MV relief expected
- Times
 - Given in hours
 - Report time till first MW of relief achieved
 - Report time till last MW of relief achieved

Part G

Resource Limited Units

PART G: Resource Limited Unit (Any unit with less than 72 hours at maximum capacity)						
NOTE: Resource limited units should be placed under the appropriate category in PART A, if applicable. Notify the Scheduling Coordinator immediately if a Steam unit has < 32 hours or CT's has < 16 hours available						
Unit Name	Fuel Type	Maximum Capacity	Emergency Minimum	Current Energy	Total Burn Hours Remaining	Comments

- Note units that cannot cycle in comments and report emergency min level
- Note units limited for resources other than fuel in comments section

What if unit has alternate fuel??

- If alternate fuel gives > 72 hours at max capacity, do not need to report in Part G
- However if switching to secondary fuel involves a unit shut-down that introduces credible risk of not being able to restart unit, then unit should be reported if primary fuel would produce less than 72 hours of runtime at max capacity

Highlights

- PJM's Use of Collected Data
 - Used in conjunction with other collected data to assess the severity of the situation
 - Reports compiled based on the data for public distribution and to lead strategy discussions during SOS conference calls
- Confidentiality
 - Reports or group discussions will involve aggregate fuels information only - specific unit or company status will only be discussed individually with those companies
 - Once data analyzed and area of concern addressed, data and any notes will be destroyed



Highlights (continued)

- Operation of Fuel Limited Units
 - Scheduling of Units
 - Steam Units with less than 32 hours of fuel or CTs with less than 16 hours of fuel MUST be bid as Maximum Emergency if PJM is in a Hot or Cold Weather Alert
 - If PJM has particular concerns over individual unit availability due to fuel limitations, they will initiate individual communications with the units owner
 - If Unit is asked to operate differently than what was accepted in the day ahead market (in order to conserve resources), the unit would be paid its lost opportunity cost for the accepted hours it was not run

- Supplemental Status Report has been incorporated into eDART
- Transmission Owners supply Voluntary Customer Load Curtailment (VCLC) and Active Load Management (ALM) information
- Generation Owners supply Resource Limitations (fuel shortages, Emissions restrictions, etc) and Capacities
- Summary SSR Report available on eDART

https://edarttrain.pjm.com/mui/index.htm - Microsoft Internet Explorer provided by PJM Interconnection

File Edit View Favorites Tools Help

Back Forward Stop Home Search Favorites History Print Mail

Address https://edarttrain.pjm.com/mui/index.htm Go Links

mywebsearch Search Customize Cursor Mania Smiley Central Screensavers

PJM Status Report

General

- View Current System Report
- View today's Peak Report
- View previous Peak Report

Status Report

- Load Mgmt.
- Res. Limit
- On Cost Max Emerg.
- Reports

Gen Check out

- Tod...
- Tomorrow
- Historical
- Ack. Reports

Trans. Companies click on Load Mgmt

EES
eData
OASIS
CAM

EDIT

- Trans. Tickets
- TERM
- Instantaneous Reserve Check
- Minimum Gen. Report
- PJM Status Report
- NERC Data
- Restoration Data
- Logout

©1999 PJM Interconnection L.L.C.

Done Trusted sites

Start Inbo... Pow... http... PJM... 100% 10:00 AM

https://edarttrain.pjm.com/mui/index.htm - Microsoft Internet Explorer provided by PJM Interconnection

File Edit View Favorites Tools Help

Back Forward Stop Home Search Favorites History Print Mail

Address https://edarttrain.pjm.com/mui/index.htm Go Links

mywebsearch Search Customize Cursor Mania Smiley Central Screensavers

eSuite

Load Management Data Today

User Name: **supertrain** Company: **GPU Energy** Request ID: **856**

	PJMCZ	Mid Atl
ALM Step 1 & 3	<input type="text"/>	0
ALM Step 2 & 4	<input type="text"/>	0
VCLC	<input type="text"/>	0
Total	0	0

No Load **Submit Form** **Main Menu**

Trans. Companies if no load management data click on No Load

Trans. Companies enter ALM & VCLC data and click Submit Form

©1999 PJM Interconnection L.L.C.

Done Trusted sites 100% 10:02 AM

https://edarttrain.pjm.com/mui/index.htm - Microsoft Internet Explorer provided by PJM Interconnection

File Edit View Favorites Tools Help

Back Forward Stop Home Search Favorites History Print Mail

Address https://edarttrain.pjm.com/mui/index.htm Go Links

mywebsearch Search Customize Cursor Mania Smiley Central Screensavers

PJM Status Report

General

- View Current System Report
- View today's Peak Report
- View previous Peak Report

Status Report

- Load Mgmt.
- Res. Limit
- On Cost Max Emerg.
- Reports

Gen Checkout

- Today
- Tomorrow
- Historical
- Ack. Reports

Gen. Companies click on Res. Limit and On Cost Max. Emerg.

©1999 PJM Interconnection L.L.C.

Done Trusted sites 100% 10:00 AM

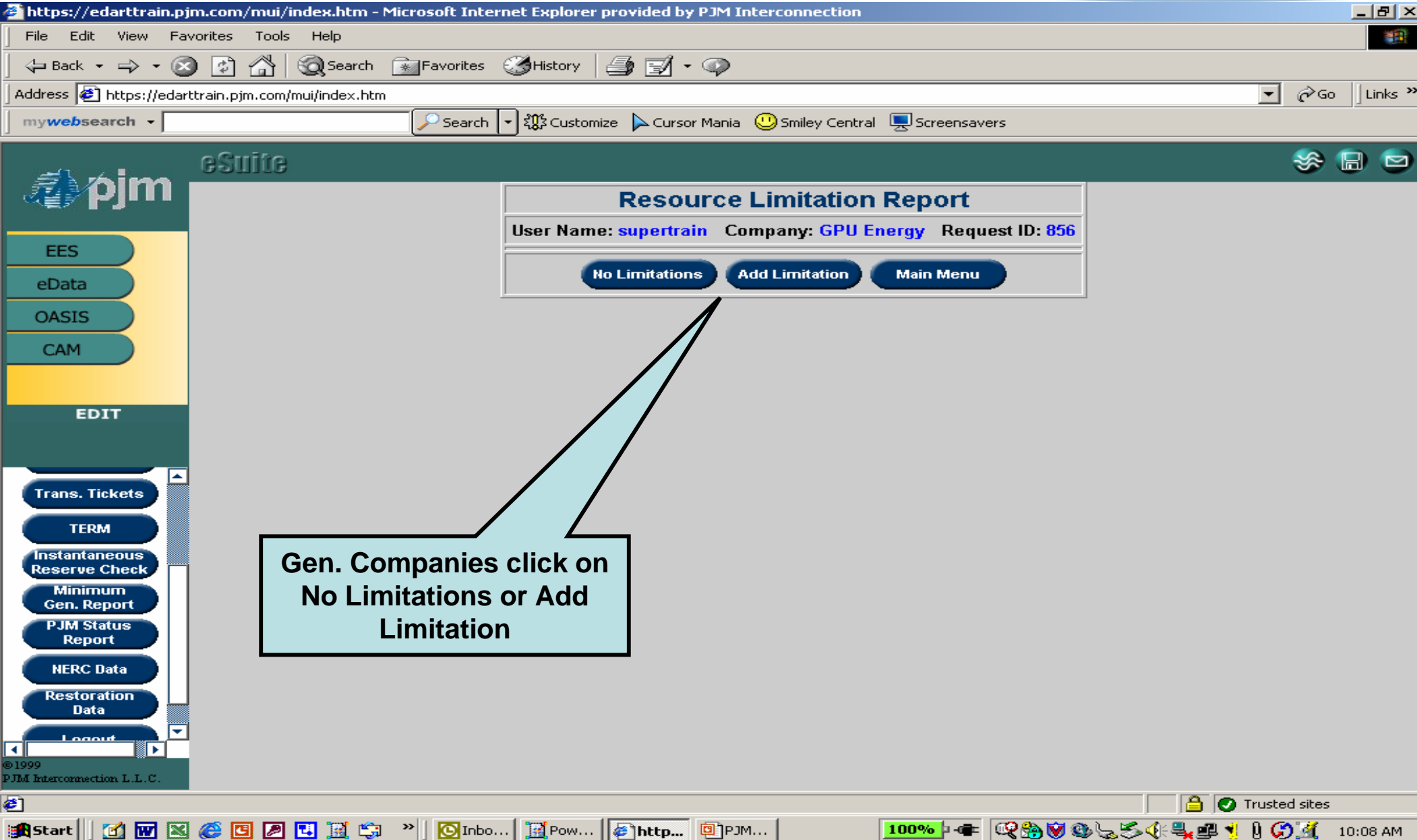

https://edarttrain.pjm.com/mui/index.htm - Microsoft Internet Explorer provided by PJM Interconnection

File Edit View Favorites Tools Help

Back Forward Stop Home Search Favorites History Print Mail

Address <https://edarttrain.pjm.com/mui/index.htm> Go Links

mywebsearch Search Customize Cursor Mania Smiley Central Screensavers

eSuite

Resource Limitation Report

User Name: **supertrain** Company: **GPU Energy** Request ID: **856**

No Limitations **Add Limitation** **Main Menu**

Gen. Companies click on No Limitations or Add Limitation

EES
eData
OASIS
CAM

EDIT

Trans. Tickets
TERM
Instantaneous Reserve Check
Minimum Gen. Report
PJM Status Report
NERC Data
Restoration Data
Logout

©1999 PJM Interconnection L.L.C.

Start Inbo... Pow... http... PJM... 100% Trusted sites 10:08 AM

https://edarttrain.pjm.com/mui/index.htm - Microsoft Internet Explorer provided by PJM Interconnection

File Edit View Favorites Tools Help

Back Forward Stop Home Search Favorites History Print Mail

Address https://edarttrain.pjm.com/mui/index.htm Go Links

mywebsearch Search Customize Cursor Mania Smiley Central Screensavers

eSuite

Add New Resource Limitation

User Name: **supertrain** Company: **GPU Energy** Request#: **856**

Generation Type:

Unit Name:

Capacity: 7

Total Remaining Hrs @ MEG:

Comments:

For Limitations select Gen Type, Name, Hrs. at Max Emerg, Comments and Submit Form

- EES
- eData
- OASIS
- CAM

EDIT

- Trans. Tickets
- TERM
- Instantaneous Reserve Check
- Minimum Gen. Report
- PJM Status Report
- NERC Data
- Restoration Data
- Logout

©1999 PJM Interconnection L.L.C.

Done Trusted sites

Start Inbo... Pow... http... PJM... 100% 10:10 AM

https://edarttrain.pjm.com/mui/index.htm - Microsoft Internet Explorer provided by PJM Interconnection

File Edit View Favorites Tools Help

Back Forward Stop Home Search Favorites History Print Mail

Address https://edarttrain.pjm.com/mui/index.htm Go Links

mywebsearch Search Customize Cursor Mania Smiley Central Screensavers

eSuite

EES

eData

OASIS

CAM

EDIT

Trans. Tickets

TERM

Instantaneous Reserve Check

Minimum Gen. Report

PJM Status Report

NERC Data

Restoration Data

Logout

On Cost Generation / Max Emerg. Today

User Name: **supertrain** Company: **GPU Energy** Request ID: **856**

	PJM CZ		Mid Atl	
	On Cost	Max Emerg.	On Cost	Max Emerg.
Diesel/CT	<input type="text"/>	<input type="text"/>	0	0
Hydro	<input type="text"/>	<input type="text"/>	0	0
Nug	<input type="text"/>	<input type="text"/>	0	0
Totals	0	0	0	0

No On Cost/Max
Submit Form
Main Menu

Gen. Owners enter On Cost and Max Emerg. Energy and Submit Form
Or
If none, click on No On Cost/Max

©1999 PJM Interconnection L.L.C.

Done Trusted sites

Start | W | E | https... | PJMDO... | 100% | 10:24 AM

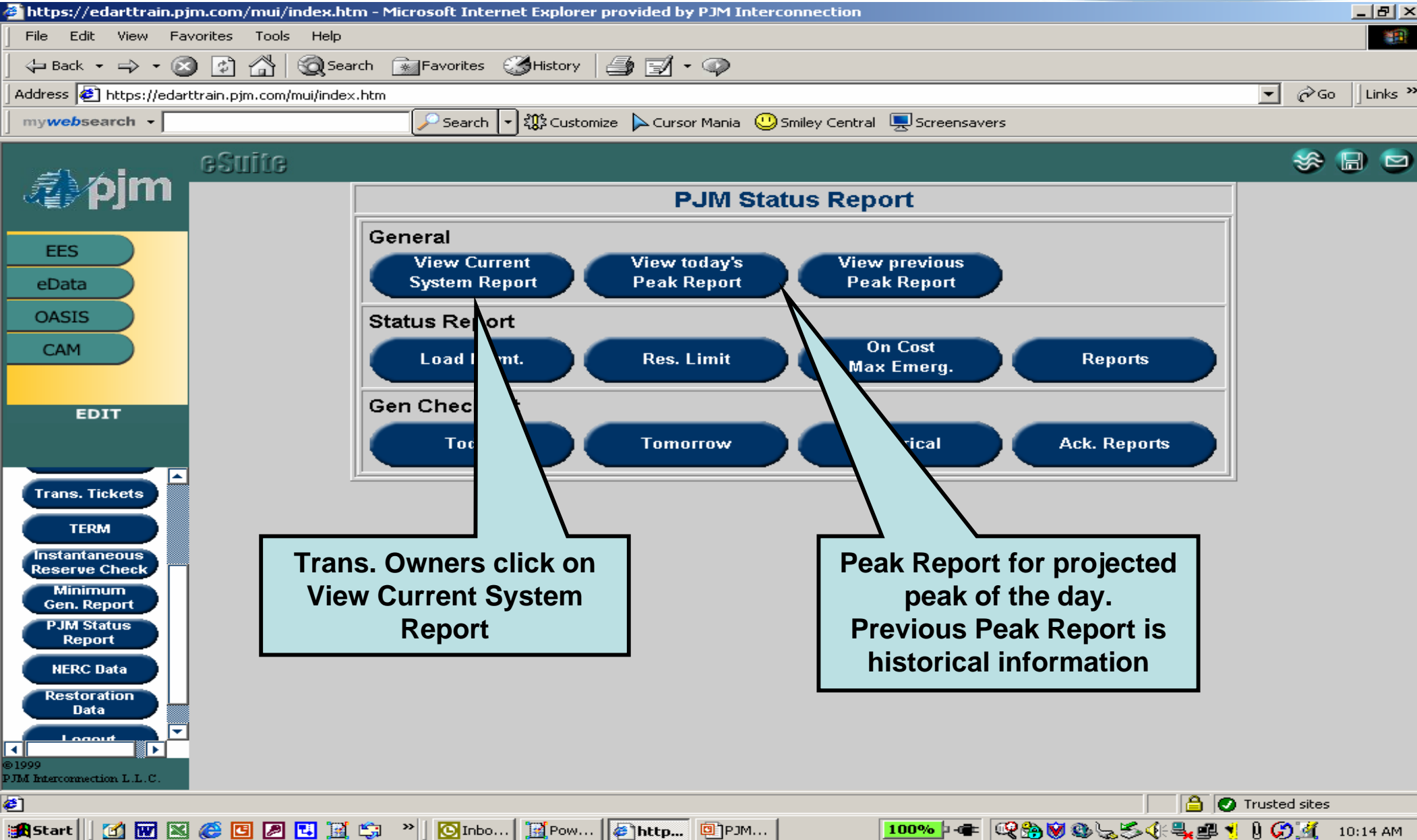

The screenshot shows the PJM eSuite web application interface. The browser address bar displays `https://edarttrain.pjm.com/mui/index.htm`. The main content area is titled "PJM Status Report" and contains several sections of buttons:

- General**
 - View Current System Report
 - View today's Peak Report
 - View previous Peak Report
- Status Report**
 - Load Limit.
 - Res. Limit
 - On Cost Max Emerg.
 - Reports
- Gen Check**
 - Today
 - Tomorrow
 - Historical
 - Ack. Reports

Two callout boxes provide additional information:

- A callout box pointing to the "View Current System Report" button states: "Trans. Owners click on View Current System Report".
- A callout box pointing to the "View today's Peak Report" button states: "Peak Report for projected peak of the day. Previous Peak Report is historical information".

The left sidebar contains navigation links for EES, eData, OASIS, CAM, and an EDIT section with various report options like Trans. Tickets, TERM, Instantaneous Reserve Check, Minimum Gen. Report, PJM Status Report, NERC Data, Restoration Data, and Logout.

©1999 PJM Interconnection L.L.C.



Supplemental Status Report - eDART

https://edarttrain.pjm.com/mui/index.htm - Microsoft Internet Explorer provided by PJM Interconnection

File Edit View Favorites Tools Help

Back Forward Stop Home Search Favorites History Print Mail

Address https://edarttrain.pjm.com/mui/index.htm Go Links

mywebsearch Search Customize Cursor Mania Smiley Central Screensavers

eSuite

pjm

EES
eData
OASIS
CAM

EDIT

Trans. Tickets
TERM
Instantaneous Reserve Check
Minimum Gen. Report
PJM Status Report
NERC Data
Restoration Data
Logout

©1999 PJM Interconnection L.L.C.

Current System Report

Date: 09/24/2004 Time: 15:31:19

Net Installed Capacity	104639	Reductions	
Reductions	19042	Unplanned	16313
Available System Capacity	85597	Planned	0
Scheduled Capacity	78001	Maintenance	2729
Unscheduled Capacity	7596	Interchange	
Scheduled Capacity	78001	AEP_CA	244
Interchange	-487	ALEXCA	-15
Load	60692	ALTECA	-100
		ALTWCA	-149
		ALWXCA	0
		AMRNCA	284
		ANALYT	-100
		CILCCA	0
		CIN_CA	0
		CPLECA	0
		CPLWCA	0
		DL_CA	53
		DUK_CA	0
		EKPCCA	0
		FE_CA	826
		IPL_CA	0
		IP_CA	823
		MECSCA	0
		MEC_CA	-316

Done Trusted sites

Start | [Icons] | [Taskbar] | 10:17 AM

- On certain forms data is split between PJM Mid-Atlantic/PJM Western/Southern Regions
- Most companies will enter data in only one of the sections based on generation location

PJM Southern Region

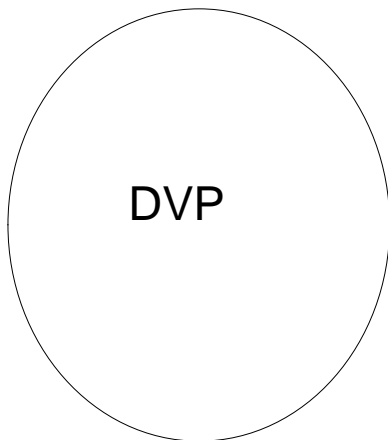

PJM Western Region

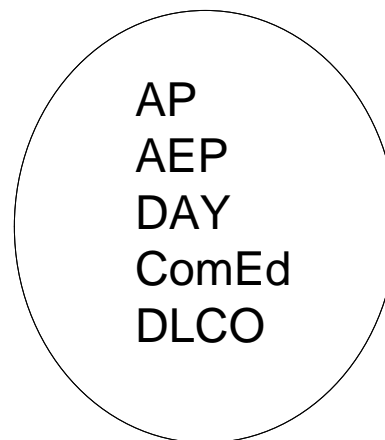

PJM Mid-Atlantic Region

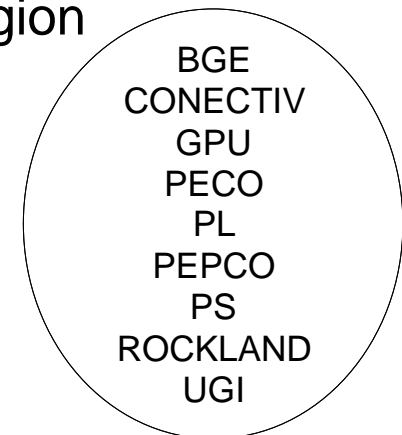

- Warnings are issued during present operations
 - To inform Members of actual capacity shortages and contingencies that may affect the reliability of the PJM Control Area
- Three Warnings:
 - Primary Reserve Warning
 - Voltage Reduction Warning and Reduction of Non-Critical Plant Load
 - Manual Load Dump Warning

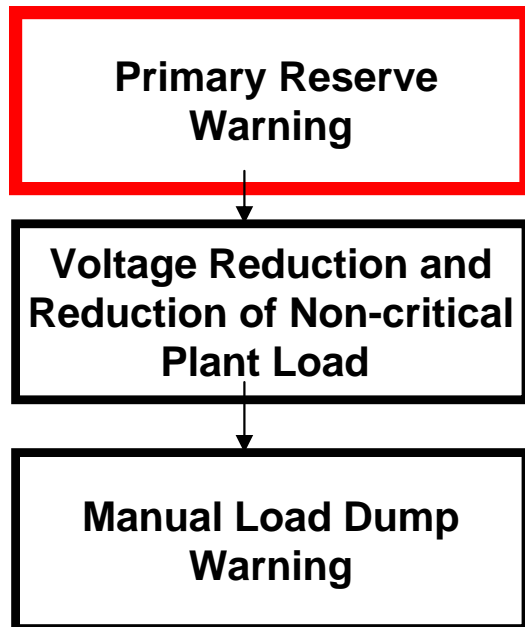

Primary Reserve Warning

- Purpose
 - To warn the Local Control Centers that the Primary Reserve is less than required and operations are getting critical
- Trigger
 - Issued when the Primary Reserve is less than the Primary Reserve requirement but greater than the Spinning Reserve requirement
 - All secondary reserve (except MW's in Max Emergency) is first moved to primary reserve status

Primary Reserve Warning

- PJM Actions
 - Notifications
 - Internal / External
 - Verify Secondary Reserve moved to Primary Status
 - Verify all deferrable maintenance or testing halted
- Member Actions
 - Notifications
 - Internal / External
 - Key Station Personnel
 - Prepare to load Primary Reserve
 - Halt any deferrable maintenance or testing

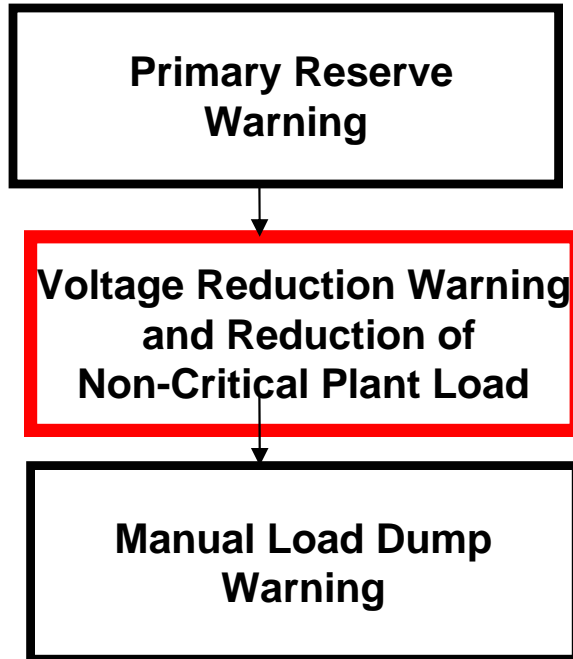

Voltage Reduction Warning

(& Reduction of Non-critical Plant Load)

- Purpose
 - To inform the Control Centers that Spinning reserve is less than required and present operation has deteriorated such that voltage reduction may be required
- Trigger
 - When Spinning Reserve is less than the requirement
 - All secondary and primary reserve (except MW's in Max Emergency) are first moved to spinning reserve status

Voltage Reduction Warning

(& Reduction of Non-critical Plant Load)

- PJM Actions
 - Notifications
 - Internal / External
 - Department of Energy (DOE)
- Member Actions
 - Notifications
 - Internal / External
 - Key Station Personnel
 - Government Agencies
 - Appropriate personnel of potential need for load management programs
 - Order all Generating Stations to curtail non-essential station light and power
 - Prepare for implementation of Voltage Reduction

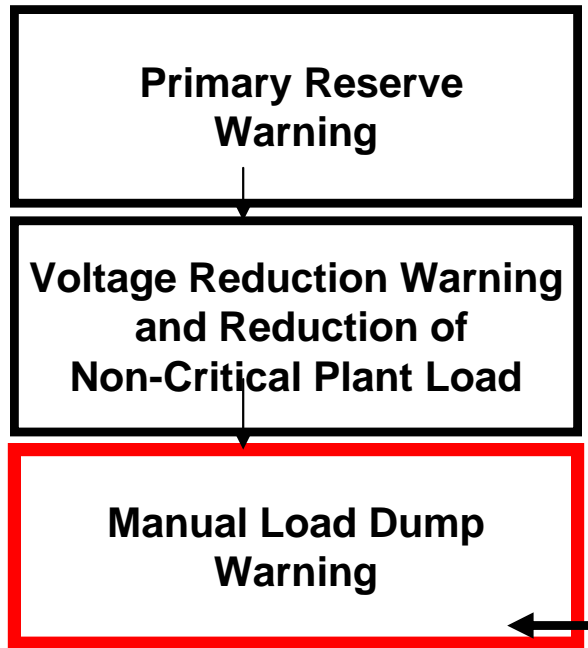

NERC EEA 3
ISSUED

Manual Load Dump Warning

– Purpose

- To warn the Local Control Centers of increasingly critical system conditions that may require manually dumping load

– Trigger

- When the Primary Reserve is less than the largest generating unit or the loss of a transmission facility jeopardizes reliability
 - All possible measures are first taken to increase reserves

Manual Load Dump Warning

- PJM Actions
 - Notifications
 - Internal / External
 - FERC Division of Reliability notified via pager
 - Establish mutual awareness with LCC's of need for action with minimum delay (post contingency)
 - Examine bulk voltages
- Member Actions
 - Notifications
 - Internal / External
 - Key Station Personnel
 - Government Agencies
 - Reinforce internal communications so load dumping can occur with minimum delay
 - Review procedures and prepare to dump load

Six Actions

- Maximum Emergency Generation
- Load Reduction Program (PJM sponsored)
- Load Management (ALM)(QIL) steps 1-4
(Company sponsored)
- Voltage Reduction/Curtailment of Non-Essential Load
- VCLC
- Manual Load Dump

Maximum Emergency Generation

- Purpose
 - To increase generation above the maximum economic level
- Trigger
 - Real-time Generation is needed to meet the load demand that is greater than the highest incremental cost level

Load and Capacity Profile

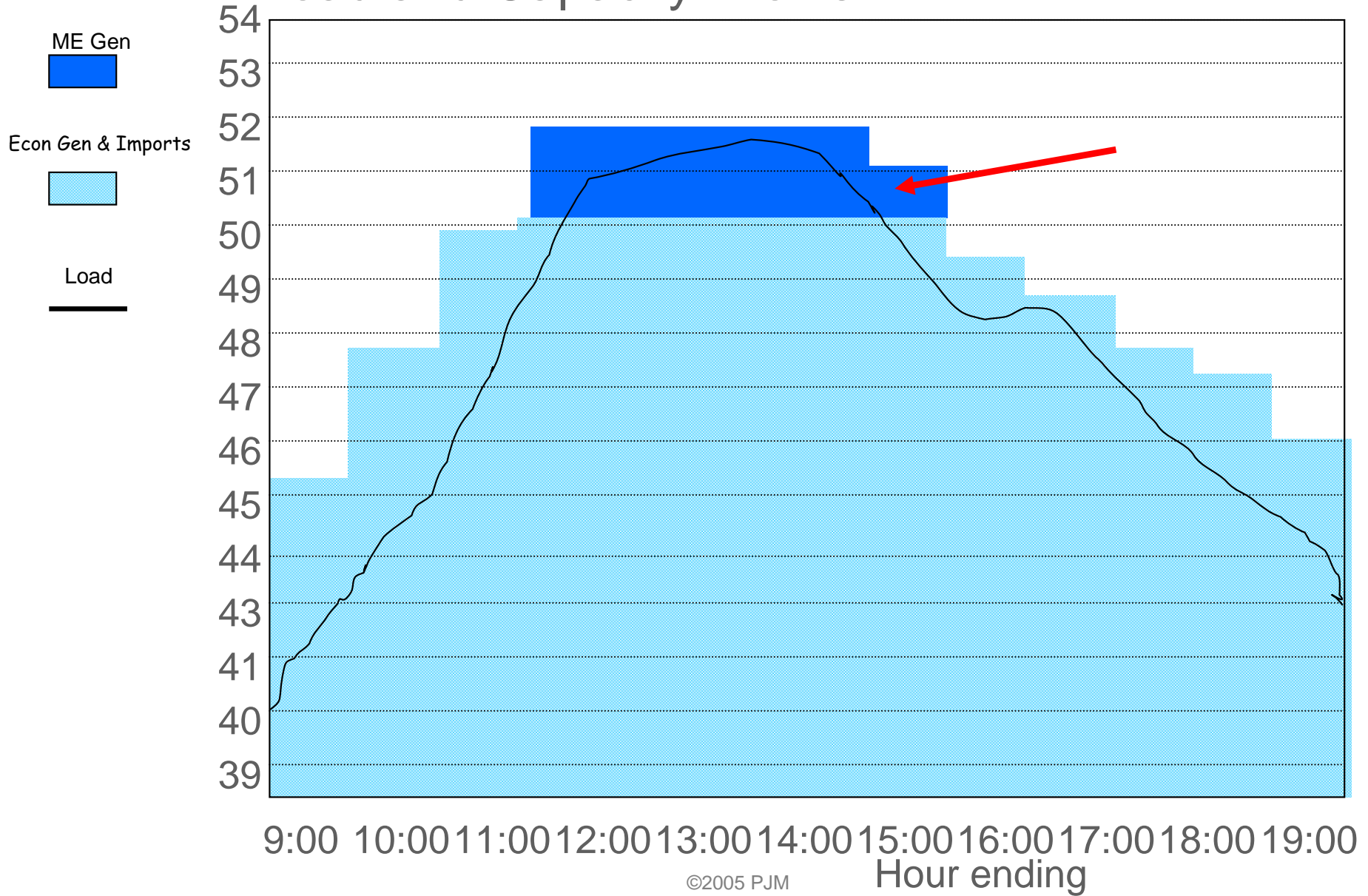

Maximum Emergency Generation

- PJM Actions

- Notifications
 - Internal / External
 - Outside Systems
 - NERC
- Request Emergency Energy (through OASIS and RCIS)
- Suspend Regulation (except hydro)
- Recall off system sales (that are recallable)
- Load Max Emergency Generation and start purchases of Emergency Bids received
 - ME CTs loaded prior to ME Steam to preserve spinning reserve

- Member Actions

- Notifications
 - Internal / External
- Recall off system sales that are recallable
- Suspend Regulation when requested
- Load Units to Max Emergency levels as requested
- Market Participants submit bids to supply Emergency Energy from sources outside PJM

- Emergency Energy Bid Form
- Found on website under Emergency Procedures
 - Purchases do not set LMP
 - Selected based on economics

Attachment H: Emergency Bid Form

Emergency Bid Form

 <small>Working to Perfect the Flow of Energy</small>	For Internal Use Emergency Energy Bid Form Phone: _____ Voice: (510) 666 - 4505 Fax: (510) 666 - 4287 ID: _____		
Date: _____ Company: _____ Representative: _____ Phone: (____) _____ - _____, Ext: _____ Control Area/Interface through which the power is being delivered: _____ NYPP Identifier (if applicable): _____ Full Path (including supplier, wheelers, marketers, brokers, receiver) _____ ¹ Notification time to accept: _____ Minimum Run Time: _____			
From – To HHMM-HHMM	Emergency Energy Available to Deliver (MW)	Bid Price of Energy (\$/MWh)	
For Capacity Baked only:			
EE# ID	From – To HHMM-HHMM	Capacity Baked Available to Cut (MW)	Bid Price of Energy (\$/MWh)
	-		
	-		
	-		
¹ Minimum time required to start the energy flowing into PJM.			

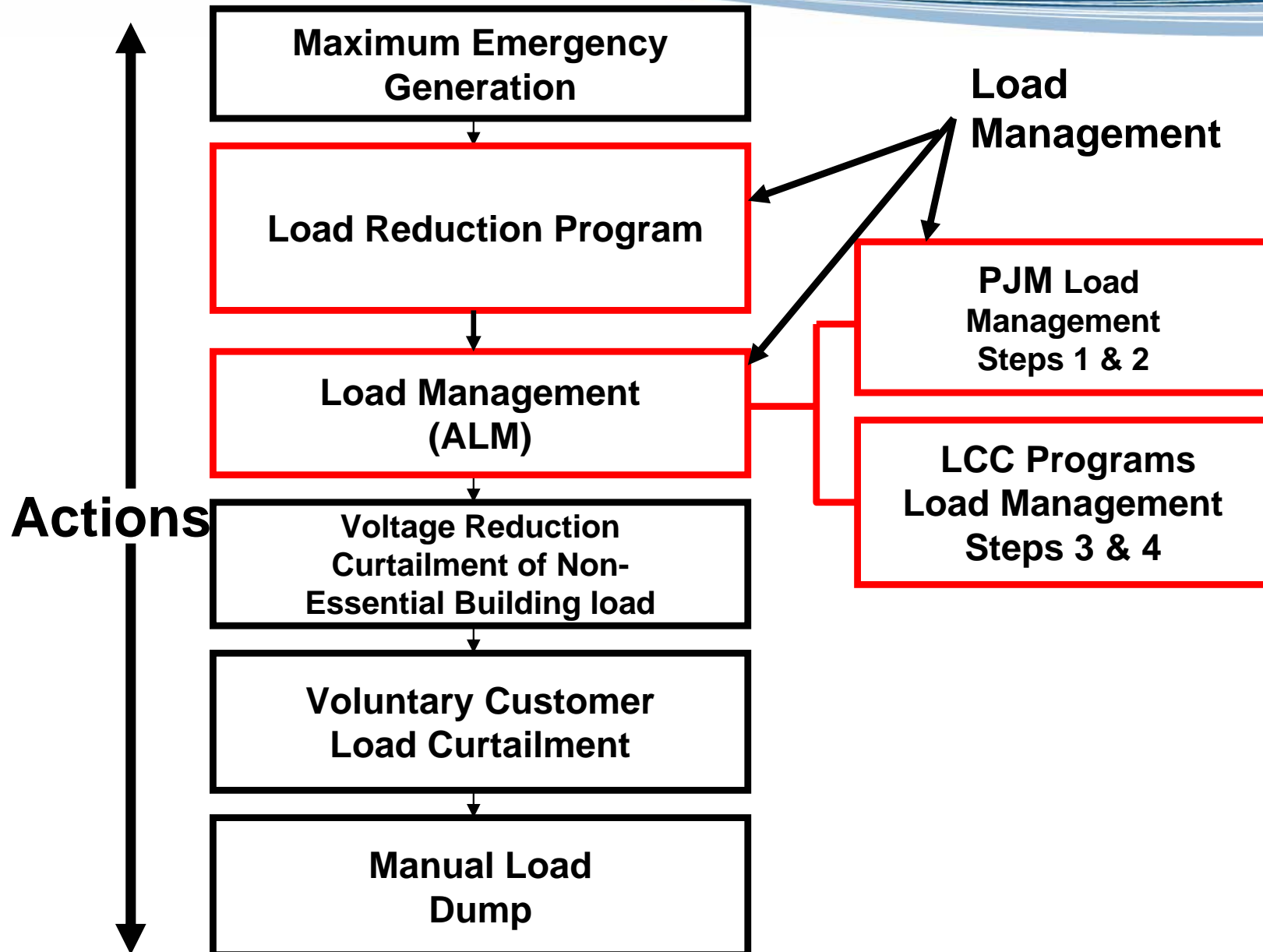

Who Can Participate?

- Any customer capable of reducing at least 100kW of load or generating at least 100kW
- Be available between 0900 and 2200 any or all days of the week.
- Achieve reduction within one hour of request.
- Be able to participate for at least 10 hrs over the course of the summer period.
- PJM offers an Emergency and Economic Load Response Program
- PJM initiates Load Reduction Program at same time ME Generation is loaded and emergency energy is purchased
- *Reduction is voluntary*



- PJM controlled and directed
- Local Control Center directed
- Have various names including, but not limited to:
 - Active Load Management (ALM)
 - Qualified Interruptible Loads (QIL)
 - Interruptibles, Curtailables, or Load Management
- To simplify operations during emergency situations all curtailments are referred to as Load Management Curtailments (or ALM).
- Can be issued system wide or by zone, depending on current or projected system conditions.
- *Reduction is mandatory (up to 10x/year)*

Load Management Curtailments

- Purpose
 - To provide additional load relief
- Trigger
 - Load Relief is required after initiating Maximum Emergency Generation
 - Note: Load Management Curtailments are not used to provide assistance to adjacent Control Areas

Load Management Curtailments

- **PJM Actions**

- Notifications
 - Internal / External
 - Outside Systems
 - NERC
- Provide LCC's an estimate of the magnitude and approximate duration of curtailment
- Suggest LCC's consider use of public appeals

- **Member Actions**

- Notifications
 - Internal / External
 - Government Agencies
- Consider use of public appeals
- Implement Load Management Programs

Voltage Reduction & Curtailment of Non-Essential Building Load

- Purpose
 - To reduce load (PJM sees about 2% decrease in load for 5% voltage reduction)
- Trigger
 - Load relief still needed to maintain ties
 - Curtailment of non-essential building load may be implemented prior to, but no later than the voltage reduction.

Voltage Reduction & Curtailment of Non-Essential Building Load

- PJM Actions

- Notifications
 - Internal / External
 - Outside Systems
 - NERC
 - DOE
- Suggest LCC's consider use of public appeals
- Request curtailment of non-essential building load
- Order 5% Voltage Reduction

- Member Actions

- Notifications
 - Internal / External
 - Government Agencies
- Consider use of public appeals
- Implement curtailment of all non-essential light and power in LSE owned commercial, operations, and administrative offices
- Implement Voltage Reduction on the Distribution level only

Voluntary Customer Load Curtailment (VCLC)

- Purpose
 - To provide further load relief
- Trigger
 - Estimated peak load, (minus relief expected from Curtailment of Non-essential Building Load and 5% Voltage Reduction) is greater than operating capacity
 - Preferably implemented at least 4 hours before peak, but can be used up to one hour before peak

Voluntary Customer Load Curtailment (VCLC)

- **PJM Actions**

- Notifications
 - Internal / External
 - Outside Systems
 - NERC
- Suggest LCC's consider use of public appeals
- Request LCC's fulfill their VCLC curtailments

- **Member Actions**

- Notifications
 - Internal / External
 - Government Agencies
- Consider use of public appeals
- Implement VCLC requirement

Manual Load Dump



- Purpose
 - To provide load relief when all other possible means have been exhausted to prevent a catastrophe within the PJM Control Area
 - Implemented only in control zone that is capacity deficient
- Trigger
 - Implemented when PJM Control Area cannot provide adequate capacity to meet load or critically overloaded transmission lines or equipment cannot be relieved in any other way

Manual Load Dump

- PJM Actions

- Notifications
 - Internal / External
 - Outside Systems
 - NERC
 - FERC
 - DOE
 - FEMA
- Suggest LCC's consider use of public appeals
- Suspend all remaining regulation
- Verify load dumping will help and not aggravate the condition
- Determine block of load required for relief
- Order LCC's to dump required amount of load

- Member Actions

- Notifications
 - Internal / External
 - Government Agencies
- Consider use of public appeals
- Suspend remaining regulation as directed by PJM
- Promptly dump an amount of load equal to or in excess of LCC's allotment of load dump order



Capacity Shortage - Actions

Example of Load shed allocation screen from PJM EMS.

PRD - Test/RealTime - PJM LFC - Regulation Availabilities

Display View Overlay Tools

	RTO	MID-ATL	AP	AEP	DPL	DLCO	CE	DOM
+ Net Zone Generation	78609	33593	6662	20053	2583	0	15719	10370
+ Net Zone Dynamic Schedules	-703	20	84	-739	-17	0	-51	0
+ Active Zone Reserve Share Energy	0	0	0	0	0	0	0	0
+ Net Zone LSE EES Schedules	0	10	10	-5	-5	0	-10	0
+ Load Share Ratio RTO Energy Schedules	-4213	-2019	-337	-1003	-109	0	-745	0
- Net Zone Load	75336	36104	6035	17938	1945	0	13314	10276
= Net Zone Energy Position (A)	-236	-4539	216	1845	540	0	1702	0
Net Zone Capacity Position (B)	-750	100	-50	0	-800	0	0	0
Net Zone Position (A + B)	-986	-4439	166	1845	-260	0	1702	0
Zone Positions		SHORT	EXCESS	EXCESS	SHORT	EXCESS	EXCESS	EXCESS
Desired Load Dump Amount	200							
Load Dump Allocation		189	0	0	11	0	0	0
+ EES Net Capacity-Backed Sales	-5							
- eCapacity Net External Capacity Sales	100							
Net Unloaded Capacity Transactions	-105							

Cancel Execute DataEntry Recall

Sep 03 2004 09:07:59



Attachment C: Manual Load Dump Allocation Tables

Winter/Summer Required Manual Load Dump PJM Mid-Atlantic Region													
MW	PS	PE	PPL Zone		BC	GPU	PEPCO Zone		AE	DPL Zone			Rockland
			PPL	UGI			PEPCO	SMECO		DPL	ODEC	Easton	
%	16.7	14.2	13.7	0.4	12.4	19.5	10.1	1.2	4.3	5.9	0.9	0.1	0.6
500	84	71	69	2	62	98	51	6	22	30	5	1	3
1000	167	142	137	4	124	195	101	12	43	59	9	1	6
1500	251	213	206	6	186	293	152	18	65	89	14	2	9
2000	334	284	274	8	248	390	202	24	86	118	18	2	12
3000	501	426	411	12	372	585	303	36	129	177	27	3	18
4000	668	568	548	16	496	780	404	48	172	236	36	4	24
5000	835	710	685	20	620	975	505	60	215	295	45	5	30

Exhibit 29: Manual Load Dump Allocation - PJM Mid-Atlantic Region

Winter/Summer Required Manual Load Dump Eastern Portion of PJM Mid-Atlantic Region Only										
MW	PS	PE	PL East	AE	DPL Zone			JC	ME East	Rockland
					DPL	ODEC	Easton			
%	29.6	25.2	5.0	7.5	10.5	1.6	0.2	18.1	1.2	1.1
500	148	126	25	38	53	8	1	91	6	6
1000	296	252	50	75	105	16	2	181	12	11
1500	444	378	75	113	158	24	3	272	18	17
2000	592	504	100	150	210	32	4	362	24	22

Exhibit 30: Manual Load Dump Allocation - Eastern Portion of PJM Mid-Atlantic Region

In PJM Mid-Atlantic Region, Manual Load Dump is allocated to each LCC on a Load Ratio Share Basis

PJM Load (Hourly Average)

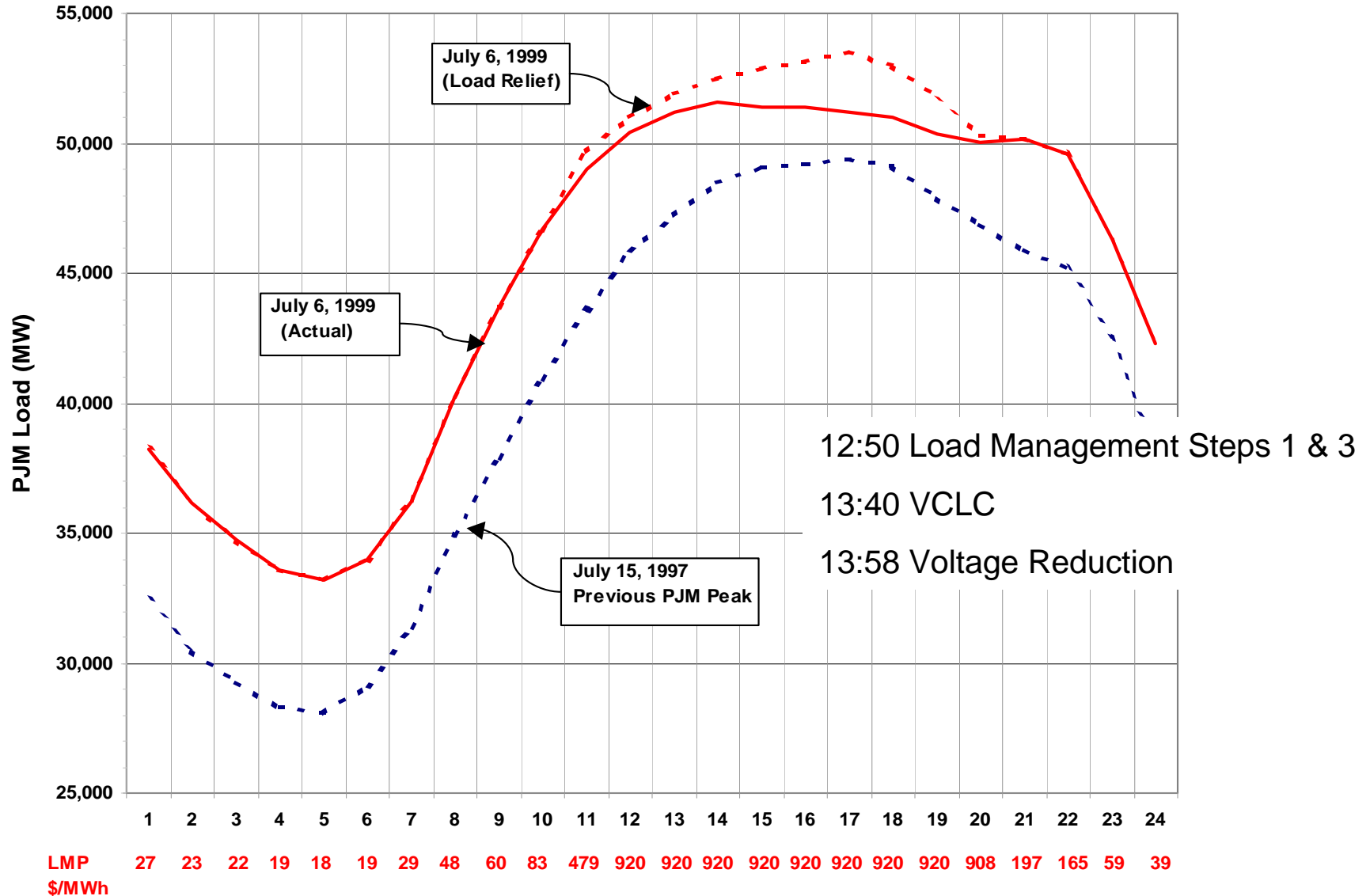



PJM - Microsoft Internet Explorer provided by PJM Interconnection

File Edit View Favorites Tools Help

Back Forward Stop Home Search Favorites History

Address <http://www.pjm.com/index.jsp> Go

Links Money.com People.com The WB Time.com Warner Bros. Online Windows Media Windows

Favorites Add... Organize >>

- Best of the Web
- Fidelity Investm...
- Business
- Entertainment
- Inside Netscape
- Lifestyle and Tr...
- Links
- Media
- Microsoft Chan...
- Microsoft Intern...
- MSNBC
- News and Tech...
- Personal Toolba...
- Search and Dire...
- The Microsoft N...
- The PointCast B...
- American Expre...
- Dispatcher Kno...
- Household Bank...
- How to Customi...
- MSN.com
- My Documents
- NabiscoWorld - ...
- notesmail01
- Online Services ...
- Radio Station G...
- WindowsMedia...

careers site map legal & privacy contact us

[pjm](#) > [About PJM](#) > [Services](#) > [Planning](#) > [eTools](#) > [Markets](#) > [Committees & Groups](#) > [Documents](#)

> search
> advanced search

Working to Perfect the Flow of Energy

PJM Interconnection is a regional transmission organization (RTO) that plays a vital role in the U.S. electric system.

- PJM ensures the reliability of the largest centrally dispatched control area in North America by coordinating the movement of electricity in all or parts of Delaware, Illinois, Maryland, New Jersey, Ohio, Pennsylvania, Virginia, West Virginia and the District of Columbia.
- PJM, acting neutrally and independently, operates the largest competitive wholesale electricity market in the world.
- PJM manages a sophisticated regional planning process for generation and transmission expansion to assure future electric reliability.
- PJM facilitates a collaborative stakeholder process. Stakeholders include participants that produce, buy, sell, move and regulate electricity.

Quick Links

Go to...

> **Emergency Procedures**

The RTO Load and LMP Data are Temporarily Unavailable

Done Trusted sites

Start In... P... PJ... PJ... ht... Mi... 98% 1:34 PM



Emergency Messages

Region: PJM - RTO
NICA - Control Area
PJMCA - Control Area
Eastern - Control Zone

Message Type: Max Emerg Gen Action Trans
Max Emerg Gen Alert
Min Gen Declaration
Min Gen Event

From: **To:**

Active Only: **Last 2 Days:** **Flowgate Number:**

Apply Filter

Reset Filter

1	Msg. ID	Msg. Type	Date/Time	Region Area	Emergency Message	Cancel Date/Time
	23436	TLR Level 0	09/13/2004 15:33	AP Transmission Zone	TLR Level 0 for AP - Transmission Zone As of 15:33 hours, a TLR Level 0 has been issued for control of flowgate 2358 , Wylie Ridge #5 345/500kV Transformer for L/O Wylie Ridge#7 345/500kv	09/13/2004 15:34
	23435	TLR Level 1	09/13/2004 08:27	AP Transmission Zone	TLR Level 1 for AP - Transmission Zone As of 08:27 hours, a TLR Level 1 has been issued for control of flowgate 2358 , Wylie Ridge #5 345/500kV Transformer for L/O Wylie Ridge#7 345/500kv	09/13/2004 15:33
	23434	TLR Level 3a	09/13/2004 07:28	AP Transmission Zone	TLR Level 3a for AP - Transmission Zone As of 07:28 hours, a TLR Level 3A has been issued for control of flowgate 2358 , Wylie Ridge #5 345/500kV Transformer for L/O Wylie Ridge#7 345/500kv	09/13/2004 08:27
	23433	TLR Level 1	09/12/2004 22:24	AP Transmission Zone	TLR Level 1 for AP - Transmission Zone As of 22:23 hours, a TLR Level 1 has been issued for control of flowgate 2358 , Wylie Ridge #5 345/500kV Transformer for L/O Wylie Ridge#7 345/500kv	09/13/2004 07:28

- Emergency Message
- Message Definition**
- Emergency Bid Form
- Logout



File Edit View Favorites Tools Help

Back Forward Stop Home Search Favorites History Print Mail

Address https://emergproc.pjm.com/ep/guest_login.htm Go

Links Money.com People.com The WB Time.com Warner Bros. Online Windows Media Windows

Favorites X

Add... >>

- Bes...
- Fid...
- Bus...
- Ent...
- Insi...
- Life...
- Links
- Media
- Mic...
- Mic...
- MS...
- Ne...
- Per...
- Se...
- Th...
- Th...
- Am...
- Dis...
- Ho...
- Ho...
- MS...
- My...
- Na...
- not...
- Onl...
- Ra...
- Wi...



Emergency Messages

Message Definition

Emergency Bid Form

Logout

Message Definitions	
Message Type	Definition
Cold Weather Alert	Is to prepare personnel and facilities for expected extreme cold weather conditions.
Curtl Bldg Load	PJM and Member facilities may be implemented at the same time.
DISREGARD -- TEST MESSAGE	Test Message, no action required
Emergency Energy Request	This is a request by PJM for emergency purchases of energy. PJM will select which offers are accepted based on price and expected duration of the need. This request is typically issued at the Max Emergency Generation emergency procedure step. The Emergency Energy Bid Form can be found on the webpage for Emergency Conditions.
HLV Action	Is issued to members (Generation and Transmission) at peak load periods via the ALL-CALL system to request maximum support of voltages on the bulk power system and increase reactive reserves on the 500kv system.
HLV Warning	Is issued to members via the ALL-CALL system (Generation and Transmission) to request members to prepare for maximum support of voltages on the bulk power system.
Hot Weather Alert	Is to prepare personnel and facilities for extreme hot and/or humid weather conditions which may cause capacity requirements/unit unavailability to be substantially higher than forecast are expected to persist for an extended period..
Load Dump Warning	To warn members of the increasingly critical condition of present operations that may require manually disconnecting firm customer load (rotating blackouts).
Load Mgmt Curtail Step 1	The purpose is to request end-use customers contracted under loadmanagement programs (ALM) to reduce load. Target: Electric Distribution Companies
Load Mgmt Curtail Step 2	The purpose is to request end-use customers contracted under loadmanagement programs (ALM) to reduce load. Target: Electric Distribution Companies
Load Mgmt Curtail Step 3	The purpose is to request end-use customers contracted under load management programs (ALM) to reduce load. Target: Electric Distribution Companies

Start | I... P... P... P... h... M... | 98% | Trusted sites | 1:38 PM

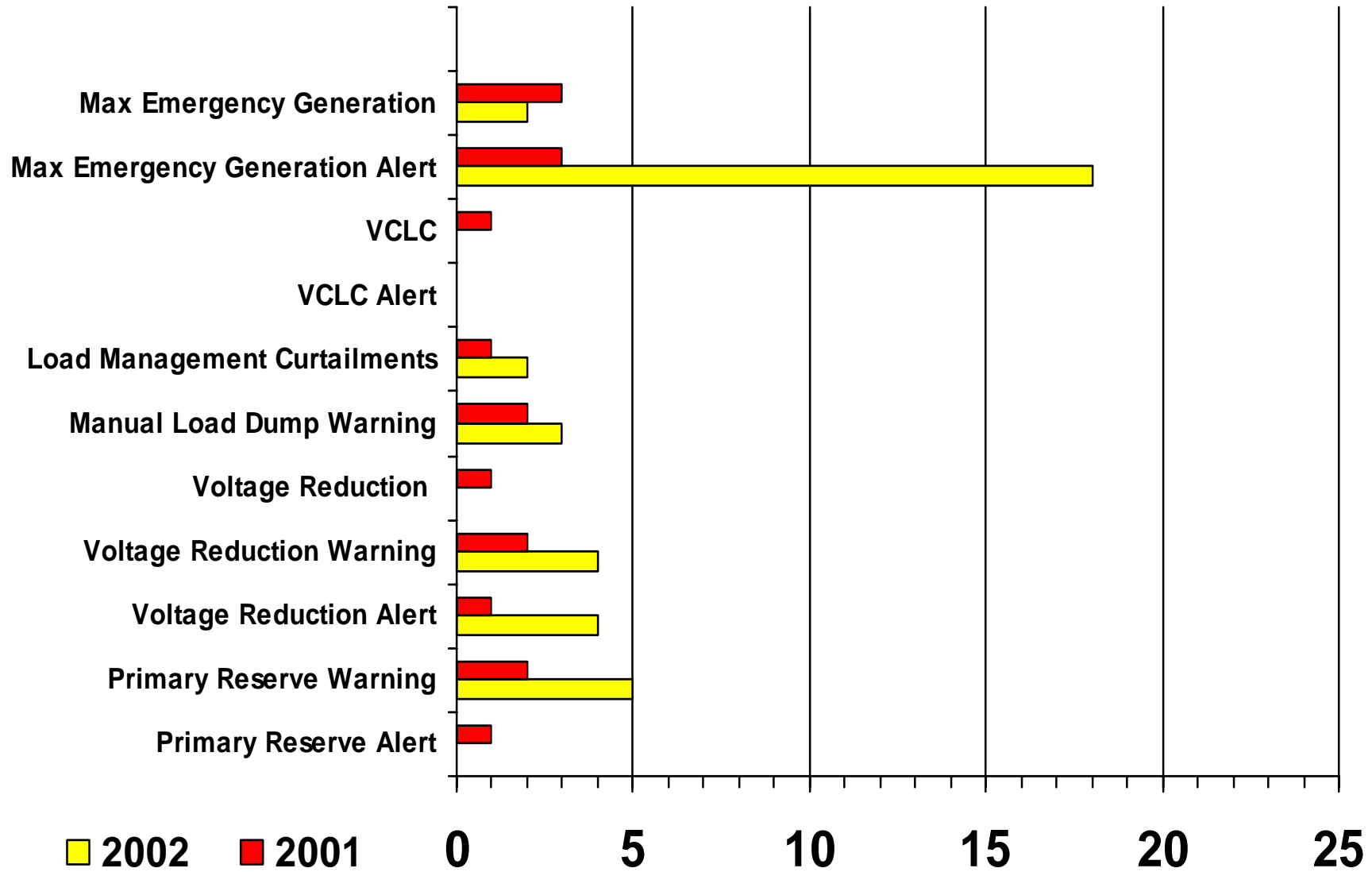

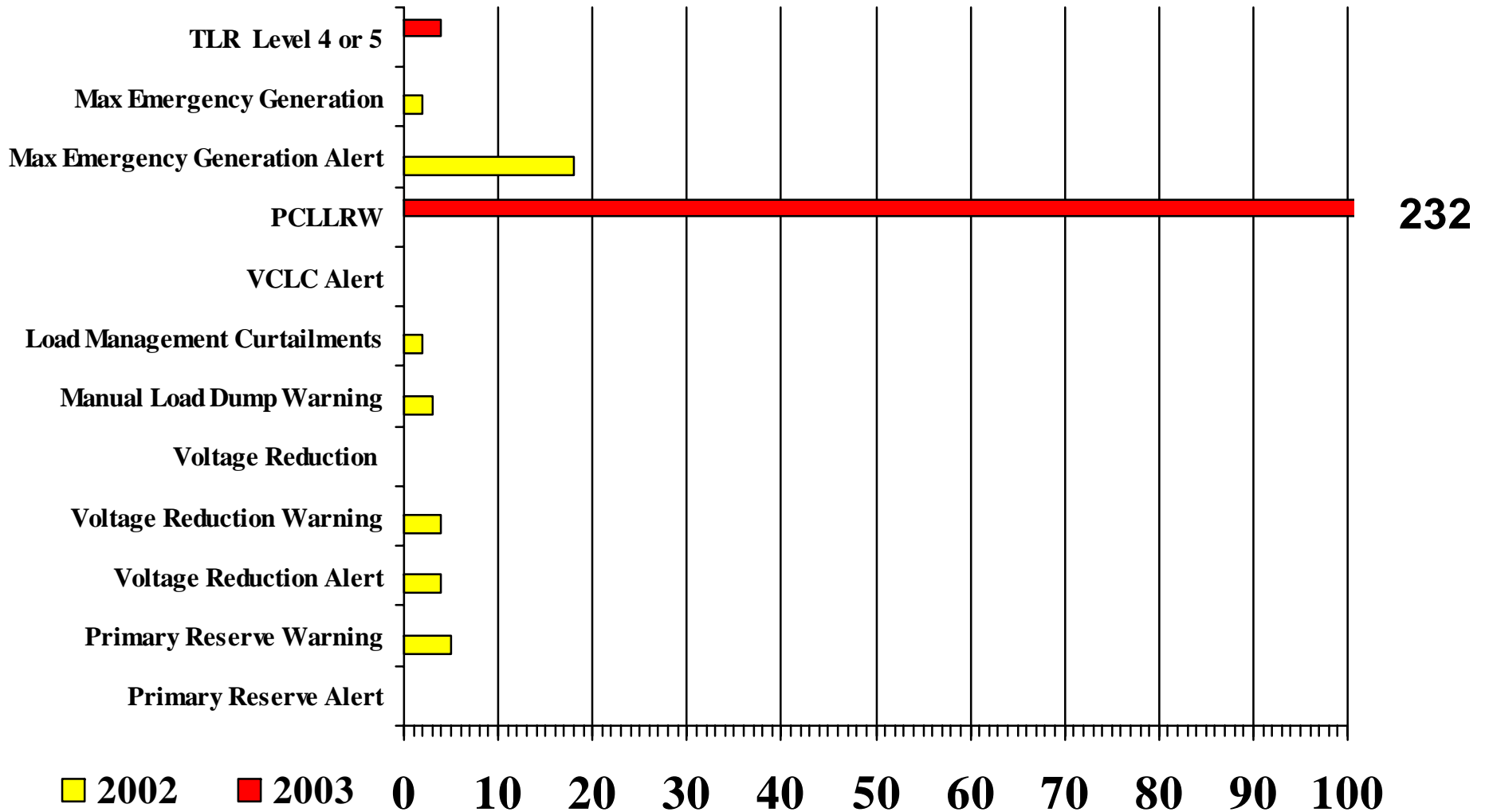



Emergency Procedures - 2003

RTO Emergency Procedures Summary

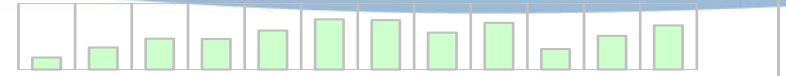

RTO Emergency Procedures Summary			Jan	Feb	Mar	Apr	May	Jun	Jul	Aug	Sep	Oct	Nov	Dec	YTD		
Events	Procedure	Dec	Description														
	100% Spinning Reserve - PJM & RTO	3	(2) Eastern Transfers, (1) Other		8	4	5	9	3	5	6	3	8	7	3	3	64
	100% Spinning Reserve - PJM West Only	1	(1) Western Transfers		7	1	1	3	6	1	2	1	2	1	1	1	27
	Shared Reserve Activation (SAR)	5	(1) NY, (4) NE		5	1	6	2	1	7	4	4	3	5	3	5	46
	APS ARS (Quarterly)						1			0			1			0	2
	Voltage Reduction Alert																0
	Voltage Reduction Warning																0
	Voltage Reduction																0
	Reactive Limitation Control																0
	Solar Magnetic Disturbances																0
	Post Contingency Local Load Relief Warning	19			16	21	12	23	18	34	20	14	24	8	23	19	232
	High Voltage																0
	Low Voltage																0
Transmission			(2) Cedar-Rose, (13) Clover-Lex, (33) Kanawha-Matt, (1) S.Canton-Star, (1) Twin-Branch-Argenta, (28) Wylie TX 5, (4) Wylie TX 7		6	34	55	51	62	68	92	63	76	34	62	82	685
	TLR Level 1	82															0
	TLR Level 2																0
	TLR Level 3	57	(1) Cedar-Rose, (7) Clover-Lex, (21) Kanawha-Matt, (24) Wylie TX 5, (4) Wylie TX 7		2	23	35	21	36	35	53	39	45	20	35	57	401
	TLR Level 4						1	4									5
	TLR Level 5						1	3									4
Generation / Capacity	Maximum Emergency Generation Alert																0
	Maximum Emergency Generation																0
	Maximum Scheduled Generation																0
	Minimum Generation Alert				1				13	21	7	9	10	2	1		64
	Minimum Generation Declaration								5	10	3	5	6	1			30
	Minimum Generation Event								4	10		2	2	0			18
	Primary Reserve Alert																0
Primary Reserve Warning																	0
System	Cold Weather Alert																0
	Hot Weather Alert																0
	Voluntary Customer Load Curtailment Alert																0
	Voluntary Customer Load Curtailment																0
	Radio & TV Load Curtailment Appeal																0
	Curtail of Non-essential Building Load																0
	Emergency Sales																0
	Load Dump Warning - System																0
Load Management Curtailments																0	
Total	167			45	84	117	116	148	191	187	140	177	78	128	167	1578	