



*Working to Perfect the Flow of Energy*

PJM Manual 14B:  
PJM Region Transmission  
Planning Process

Revision: 21

Effective Date: April 26, 2012

Prepared by  
Planning Division  
Transmission Planning Department

© PJM 2012



## PJM Manual 14B:

# PJM Region Transmission Planning Process

### Table of Contents

<b>Table of Contents</b> .....	<b>ii</b>
<b>Table of Exhibits</b> .....	<b>5</b>
<b>Approval</b> .....	<b>1</b>
<b>Current Revision</b> .....	<b>1</b>
<b>Introduction</b> .....	<b>2</b>
ABOUT PJM MANUALS.....	2
ABOUT THIS MANUAL.....	2
<i>Intended Audience</i> .....	2
<i>References</i> .....	3
USING THIS MANUAL .....	3
<i>What You Will Find In This Manual</i> .....	4
ABOUT CRITICAL ENERGY INFRASTRUCTURE INFORMATION (CEII).....	4
<i>PJM Critical Energy Infrastructure Information Release Guidelines</i> .....	4
<b>Section 1: Process Overview</b> .....	<b>7</b>
1.1 PLANNING PROCESS WORK FLOW .....	7
1.2 TEAC AND SUBREGIONAL RTEP COMMITTEE AND RELATED ACTIVITIES .....	8
1.3 PLANNING ASSUMPTIONS AND MODEL DEVELOPMENT .....	10
1.3.1 <i>Reliability Planning</i> .....	10
1.3.2 <i>Market Efficiency Planning</i> .....	10
1.4 RTEP PROCESS KEY COMPONENTS .....	11
1.5 PLANNING CRITERIA .....	12
1.5.1 <i>Reliability Planning</i> .....	12
1.5.2 <i>Market Efficiency Planning</i> .....	13
<b>Section 2: Regional Transmission Expansion Plan Process</b> .....	<b>14</b>
2.1 TRANSMISSION PLANNING = RELIABILITY PLANNING + MARKET EFFICIENCY .....	14
2.2 THE RTEP PROCESS DRIVERS .....	17
2.3 RTEP RELIABILITY PLANNING .....	20
2.3.1 <i>Establishing a Baseline</i> .....	20
2.3.2 <i>Baseline Reliability Analysis</i> .....	20
2.3.3 <i>Near-Term Reliability Review</i> .....	21
2.3.4 <i>Reference System Power Flow Case</i> .....	22
2.3.5 <i>Contingency Definitions</i> .....	22
2.3.6 <i>Baseline Thermal Analysis</i> .....	23
2.3.7 <i>Baseline Voltage Analysis</i> .....	23
2.3.8 <i>NERC Category C3 “N-1-1” Analysis</i> .....	24
2.3.9 <i>Load Deliverability Analysis</i> .....	26
2.3.10 <i>Generation Deliverability Analysis</i> .....	27
2.3.11 <i>Light Load Reliability Analysis</i> .....	28
2.3.12 <i>Baseline Stability Analysis</i> .....	28
2.3.13 <i>Long Term Reliability Review</i> .....	28
2.3.14 <i>Stakeholder review of and input to Reliability Planning</i> .....	30



2.4 RTEP INTEGRATES BASELINE ASSUMPTIONS, RELIABILITY UPGRADES AND REQUEST EVALUATIONS....	31
2.5 RTEP COST RESPONSIBILITY FOR REQUIRED ENHANCEMENTS .....	32
2.6 RTEP MARKET EFFICIENCY PLANNING .....	33
2.6.1 Market Efficiency Analysis and Stakeholder Process.....	33
2.6.2 Determination and evaluation of historical congestion drivers .....	34
2.6.3 Determination of projected congestion drivers and potential remedies.....	34
2.6.4 Evaluation of cost / benefit of advancing reliability projects .....	35
2.6.5 Determination and evaluation of cost / benefit of potential RTEP projects specifically targeted for economic efficiency .....	36
2.6.6 Determination of final RTEP market efficiency upgrades .....	36
2.6.7 Submitting Alternative Proposals .....	38
2.6.8 Ongoing Review of Project Costs .....	38
2.7 EVALUATION OF OPERATIONAL PERFORMANCE ISSUES.....	38
2.7.1 Operational Performance Metrics .....	39
2.7.2 Probabilistic Risk Assessment of PJM 500/230 kV Transformers.....	39
<b>Attachment A: PJM Baseline Cost Allocation Procedures .....</b>	<b>41</b>
A.1 PURPOSE.....	41
A.2 SCOPE.....	41
A.3 SCHEDULE 12 COST ALLOCATION PROCESS FOR BASELINE TRANSMISSION RELIABILITY AND MARKET EFFICIENCY UPGRADES .....	41
A.3.1 RTEP Baseline Cost Allocation .....	41
<b>Attachment B: Regional Transmission Expansion Plan—Scope and Procedure</b>	<b>44</b>
B.1 PURPOSE.....	44
B.2 SCOPE.....	44
B.3 PROCEDURE .....	46
B.4 SCENARIO PLANNING PROCEDURE.....	50
<b>Attachment C: PJM Deliverability Testing Methods .....</b>	<b>52</b>
C.1 INTRODUCTION.....	52
C.2 DELIVERABILITY METHODOLOGIES .....	52
C.3 OVERVIEW OF DELIVERABILITY TO LOAD.....	53
C.4 PJM LOAD DELIVERABILITY PROCEDURE—CAPACITY EMERGENCY TRANSFER OBJECTIVE (CETO) .	55
C.5 PJM LOAD DELIVERABILITY PROCEDURE—CAPACITY EMERGENCY TRANSFER LIMIT (CETL).....	55
C.6 DELIVERABILITY OF GENERATION.....	65
C.7 GENERATOR DELIVERABILITY PROCEDURE.....	66
<b>Attachment D: PJM Reliability Planning Criteria.....</b>	<b>71</b>
<b>Attachment D-1: Load Loss Definitions.....</b>	<b>73</b>
<b>Attachment D-2: PJM Reliability Planning Criteria Methods.....</b>	<b>74</b>
D-2.1 LIGHT LOAD RELIABILITY ANALYSIS.....	74
D-2.2 LIGHT LOAD RELIABILITY ANALYSIS PROCEDURE .....	74
<b>Attachment E: Market Efficiency Analysis Economic Benefit / Cost Ratio     Threshold Test .....</b>	<b>77</b>
E.1 TOTAL ANNUAL ENHANCEMENT BENEFIT .....	77
E.2 TOTAL ANNUAL ENHANCEMENT COST .....	79
<b>Attachment F: Determination of System Operating Limits used for planning the     Bulk Electric System.....</b>	<b>80</b>
<b>Attachment G: PJM Stability, Short Circuit and Special RTEP Practices and     Procedures .....</b>	<b>84</b>



G.1 STABILITY .....	84
G.2 DYNAMICS PROCEDURES .....	85
G.2.1 Dynamics Reference Cases.....	85
G.2.2 Dynamics Analysis .....	85
G.3 SYSTEM IMPACT STUDY AND INITIAL STUDY STABILITY PROCEDURES .....	88
G.3.1 Stability Data Requirements.....	88
G.3.2 System Impact Study Stability Scope and Process .....	89
G.4 SYSTEM STABILITY STUDIES.....	91
G.4.1 NERC Category C3 “N-1-1” System Stability Studies .....	92
G.5 IMPACT STUDY PROCEDURES APPLICABLE TO WIND TURBINE ANALYSES .....	94
G.5.1 Wind Project Final Impact Study Data .....	95
G.5.2 Wind Project LVRT Requirements .....	95
G.5.3 Wind Project Reactive Power Modeling.....	95
G.6 STABILITY ANALYSES OF STABILITY SENSITIVE LOCAL AREAS IN PJM.....	96
G.7 SHORT CIRCUIT .....	96
G.8 NUCLEAR PLANT SPECIFIC IMPACT STUDY PROCEDURES .....	97
G.9 APPENDIX TO MANUAL 14B ATTACHMENT G .....	98
G.9.1 Testing of Transmission Owner Criteria.....	98
G.9.2 Nuclear Station Testing.....	99
G.9.3 BG&E Specific Criteria .....	99
G.9.4 ComEd Specific Criteria .....	100
G.9.5 PPL Specific Criteria .....	100
G.9.6 Implementation of the NPIR for Planning Analysis .....	100
G.10 NERC STANDARD PRC-023 – TRANSMISSION RELAY LOADABILITY.....	136
<b>Attachment H: Power System Modeling Data.....</b>	<b>137</b>
H.1 POWER SYSTEM MODELING DATA .....	137
H.1.1 Load Flow Analysis Models.....	137
H.1.2 Load Flow Modeling Requirements.....	138
H.1.3 Submittal of Load Flow Data .....	139
H.1.4 Short Circuit Analysis Models.....	140
H.1.5 Stability Analysis Models.....	141
<b>Revision History.....</b>	<b>145</b>



<b>Table of Exhibits</b>
--------------------------

<b>Exhibit 1: 24-Month Planning Cycle .....</b>	<b>15</b>
<b>Exhibit 2: Base Case Development .....</b>	<b>17</b>



**Approval**

Approval Date: 04/26/2012  
Effective Date: 04/26/2012

Paul McGlynn, General Manager  
System Planning

**Current Revision**

***Revision 21 (04/26/2012):***

- Revised Generator Deliverability procedure to limit the “Adder” contribution based on an estimated CETO for generation in the receiving end area.

## Introduction

Welcome to the **PJM Region Transmission Planning Process Manual**. In this Introductory Section you will find information about PJM manuals in general, an overview of this PJM Manual in particular and information on how to use this manual.

### About PJM Manuals

The PJM Manuals are the instructions, rules, procedures, and guidelines established by PJM for the operation, planning, and accounting requirements of the PJM RTO and the PJM Energy Market. The manuals are grouped under the following categories:

- Transmission
- PJM Energy Market
- PJM Regional Transmission Expansion
- Reserve
- Accounting and billing
- PJM administrative services

For a complete list of all PJM manuals, go to [www.pjm.com](http://www.pjm.com) and select “Manuals” under the “Documents” pull-down menu.

### About This Manual

The **PJM Region Transmission Planning Process Manual** is one of the PJM manuals in the PJM Regional Transmission Expansion group. This manual focuses on the process for planning baseline expansion facilities under the PJM Region Transmission Planning Process. Capitalized terms not defined as they are used have the meaning defined in the PJM’s Open Access Transmission Tariff (OATT) and in the Operating Agreement (OA.)

This **PJM Region Transmission Planning Process Manual** consists of two sections and related attachments. All sections and attachments are listed in the Table of Contents.

**NOTE:** While the PJM Manuals provide instructions and summaries of the various rules, procedures and guidelines for all phases of PJM’s planning process, the PJM Operating Agreement and the PJM Open Access Transmission Tariff (OATT) contain the authoritative provisions.

### Intended Audience

The intended audiences for this PJM Region Transmission Planning Process Manual include:

- Generation and Transmission Interconnection Customers and their engineering staff

**NOTE:** The term “**Transmission Interconnection Customer**”, as defined in the PJM Open Access Transmission Tariff, refers to those separate and independent entities proposing to install new or upgrade existing transmission facilities rather than an existing Transmission Owner on the PJM System that installs Regional Transmission Expansion Plan “baseline,” “economic,” “system performance” or “Supplemental projects”.

- Transmission Customers

**NOTE:** The term “**Transmission Customer**” refers to any entity requesting or utilizing transmission service on the PJM Transmission System, as defined in the PJM Open Access Transmission Tariff.

- Transmission Owners and their respective engineering staff
- Federal and state regulatory bodies
- PJM Members
- PJM staff

## References

There are other PJM documents that provide both background and detail on specific topics that may be related to topics in this manual. References with related information include:

- [PJM Manual 1: Control Center and Data Exchange Requirements](#)
- [PJM Manual 2: Transmission Service Request](#)
- [PJM Manual 3: Transmission Operations](#)
- [PJM Manual 14A: Generation and Transmission Interconnection Process](#)
- [PJM Manual 14C: Generation and Transmission Interconnection Facility Construction](#)
- [PJM Manual 14D: Generator Operational Requirements](#)
- [PJM Manual 14E: Merchant Transmission Specific Requirements](#)
- [PJM Manual 21: Rules and Procedures for Determination of Generating Capability](#)

## Using This Manual

We believe that explaining concepts is just as important as presenting procedures. This philosophy is reflected in the way we organize the material in this manual. We start each section with an overview. Then we present details, procedures or references to procedures found in other PJM manuals. The following provides an orientation to the manuals’ structure.

## What You Will Find In This Manual

- A table of contents.
- An approval page that lists the required approvals and a brief outline of the current revision.
- This Introduction and sections containing the specific transmission planning process details including assumptions, criteria, procedures and stakeholder interactions.
- Attachments that include additional supporting documents, forms, or tables.
- A section at the end detailing all previous revisions of this PJM Manual.

## About Critical Energy Infrastructure Information (CEII)

### PJM Critical Energy Infrastructure Information Release Guidelines

#### Background

The Federal Energy Regulatory Commission (“FERC” or “Commission”) considers the information filed in the FERC-715, Part 2, Part 3, and Part 6 (<http://www.ferc.gov/legal/ceii-foia/ceii.asp>) to be Critical Energy Infrastructure Information (CEII). This information contains electrical models, detailed one-line diagrams and analysis of the filer’s actual transmission system including potential weaknesses of the filer’s transmission system. PJM treats all such power flow and associated system modeling data as CEII. This includes all power flow models that are developed using or including filed data and related information used in transmission analysis such as contingency and monitored element files. Power flows specifically configured for short circuit analysis that do not contain load and typical generation dispatch are not considered CEII. Regarding all types of PJM information, however, additional consideration must be given to whether or not PJM received or originated the information as Confidential Information prior to decisions regarding its release. Confidential information is discussed in PJM documents including the Operating Agreement §18.17 and the Open Access Transmission Tariff §§222 – 223. Power flows may but generally do not contain Confidential information. Confidential information of individual members, if any, will be redacted prior to release. Some PJM power flows are special cases that contain both confidential information and CEII. For example PJM power flows originating from system operations and used for near-term operational studies often contain confidential information in addition to CEII. These cases can only be obtained with authorization through the CEII process and authorization from the responsible Operating Committee and/ or working group.

The events of 2001 prompted the Commission to reconsider its previous policy of making the FERC form 715 report publicly available. Subsequent to September 11, 2001, the Commission removed from public files all documents likely to contain detailed specifications of facilities licensed or certified by the Commission. This restriction was later expanded to include information about proposed facilities as well as those already licensed or certificated by the Commission, excluding information that simply identified the location of the infrastructure. After the events of September 11, 2001, FERC Form 715 information became subject to CEII review prior to its release. In its October 2007 Order, the Commission issued revisions to the treatment of CEII and reclassified FERC Form No. 715, Parts 1, 4, and 5 as

public. The remaining portions of the report are CEII. In the FERC Order Nos. 890 and 890A the Commission directed Transmission Providers to develop a process for handling CEII while implementing the Orders' requirements for open, transparent and participatory planning.

The PJM power flow information is a combination of CEII information filed or provided by a number of "owners" and additional information introduced by PJM, PJM Members, and non-members.

The Commission's treatment of CEII has evolved over a progression of Orders that must be read together to understand the procedures applicable to the determination and handling of CEII. In consideration of the multiple-owner nature, the sensitivity of the information, and the essential role of this information in PJM's Tariff procedures and participatory planning, PJM has implemented a process for handling and documenting such material. PJM's intent is to provide a process for eligible recipients to access CEII consistent with the Commission's standards for handling CEII material.

### **Procedure to Request Access to PJM CEII**

PJM will act as the first point of contact to process CEII requests from Members, Interconnection Customers (as defined in the PJM OATT) or active participants in PJM's eFTR or eRPM markets. In addition, employees of other RTO's, similar independent transmission organizations recognized by FERC, and NERC Planning Coordinators (interregional planning entity) may also come to PJM as a first point of contact for access to PJM CEII. PJM accommodates other RTO's and Planning Coordinators in order to carry out interregional planning responsibilities pursuant to applicable FERC orders and interregional planning agreements between and among the parties. These interregional planning entities, similar to PJM, are those that have primary responsibility for creating and protecting CEII and have their own FERC compliant processes for handling CEII in their possession. Interregional transmission planning creates the need for unique interregional business processes that accommodate Interconnection-wide exchange and sharing of CEII among eligible persons while enforcing the standards for non-disclosure of such information. When necessary, PJM establishes interregional CEII procedures that uphold the essential underlying tenants of PJM's process.

All CEII requests must be from individuals. Each individual who may view or discuss the requested CEII must complete the PJM process. To request CEII in PJM's possession, a requestor must complete a PJM CEII Request Form identifying the requestor and the need for and planned use of the requested information. The request must also be accompanied by an executed CEII Non-disclosure Agreement (NDA). These two PJM CEII documents are available from your PJM Planning contacts, the PJM CEII Contact in the NERC and Regional Coordination department or the Planning area of the PJM website. If a PJM Member or PJM Interconnection Customer desires to coordinate a consultant's access to CEII on behalf of the organization, the organization's authorized representative must submit an Authorization Form (in addition to the authorized representative's Request and CEII NDA) that identifies each individual consultant who may make individual requests for CEII on the organization's behalf. The consultant additionally must submit a Request Form and CEII NDA requesting access to the same information specified on the form of the organization's authorized representative. Entities who are not PJM members, Interconnection Customers, registered PJM auction participants, or employees of another RTO are encouraged to first seek authorization from FERC by following the procedures outlined at [www.ferc.gov/legal/ceii-foia.asp](http://www.ferc.gov/legal/ceii-foia.asp).

The field on the PJM Request Form for the FERC CEII Identification Number must be completed by individuals who have first received authorization from the Commission. This field is not applicable for any requestor who uses PJM as the first point of contact for a request. The FERC link is also useful to review the definition of CEII and the Commission's process for handling CEII and useful in understanding the PJM process.

**Requirements to become an Authorized Recipient of CEII**

PJM's process provides for release of CEII information to authorized individuals of organizations engaged in business with PJM, as detailed above. The information provided on the required documents should be sufficiently detailed to enable PJM's CEII Contact to identify the individual, the specific information requested, the need for the information, and the proposed use of the information. The requester's explanations will be used by PJM staff (i) to establish whether a requester has presented a legitimate need for the information and (ii) to weigh the need for the information against the potential harmful effects of its release. PJM reserves the right to revise its process from time-to-time, to limit access to CEII as may be appropriate in any specific instance, and to require any requestor to first seek authorization for CEII access from the Commission.

## Section 1: Process Overview

In this section you will find an overview of PJM's transmission planning process that culminates in the Regional Transmission Expansion Plan (RTEP). This process (referred to in this Manual interchangeably as the RTEP process or more generically as the PJM Region transmission planning process) is one of the primary functions of Regional Transmission Organizations (RTOs.) As such, PJM implements this function in accordance with the Regional Transmission Expansion Planning Protocol set forth in Schedule 6 of the PJM Operating Agreement.

As further described in following portions of this manual, the PJM RTEP process consists of baseline reliability reviews as well as analysis to identify the transmission needs associated with generation interconnection and merchant transmission interconnection. PJM implements the planning of interconnections as part of the broader RTEP process pursuant to the PJM Open Access Transmission Tariff (OATT.) The relationship between Interconnection planning and the RTEP is discussed in later sections of this manual and in related manuals.

### 1.1 Planning Process Work Flow

The Manual 14 series provides information regarding PJM's Planning Process to complement Schedule 6 of the PJM Operating Agreement and the planning provisions of the PJM Open Access Transmission Tariff (OATT.) These agreements can be found on-line at <http://www.pjm.com/documents/agreements.aspx>.

The PJM planning process activities, culminating in PJM's annual Regional Transmission Expansion Plan, constitute PJM's single, Order No. 890 compliant, transmission planning process. All PJM Open Access Transmission Tariff (OATT) facilities are planned through and included in this open, fully participatory, and transparent process.

PJM planning is implemented through an annual cycle centered on activities of PJM's Planning and Market Simulation functions and their interactions with members, regulatory bodies, and other interested parties primarily through the PJM Transmission Expansion Advisory Committee (TEAC), the Subregional RTEP Committee, and the PJM Planning Committee (PC) forums. This ongoing process has continued to evolve since 1997, when PJM's Regional Transmission Expansion Planning (RTEP) Protocol (codified in Schedule 6 of PJM's Operating Agreement) was approved by the Federal Energy Regulatory Commission. Since that time, the process has been expanded and enhanced in response to member and regulatory input as documented in the revisions to the OATT, PJM Manual 14 series, and the Operating Agreement Schedule 6. The current PJM Region transmission planning process includes ample opportunity for Stakeholder input through frequent oral and written exchange of information and reviews via the TEAC organizational structure. The process culminates in PJM's presentation of the RTEP for approval by the PJM Board of Managers.

There are four planning paths that ultimately culminate in the PJM RTEP. Facilities in each path allow the opportunity for early, full and transparent participation by interested PJM stakeholders. The four paths are reliability planning, economic planning, interconnection planning, and local planning.

Reliability and economic planning facilities are produced from PJM's annual planning cycle activities described in this manual, Operating Agreement Schedule 6, and portrayed in Exhibit 1. PJM leads this analysis and development of upgrades related to reliability and market efficiency planning for all facilities 100 kV and above. These facilities are designated as Bulk Electric System (BES) facilities and are subject to the NERC requirements and criteria for such facilities. The PJM analyses ensure compliance with NERC, PJM and regional criteria. In addition, the PJM led analyses also include analysis and upgrade of transmission facilities with nominal voltages below 100kV to the extent they are under PJM's operational control (see <http://www.pjm.com/markets-and-operations/transmission-service/transmission-facilities.aspx>). The TEAC, Subregional RTEP Committee, and stakeholder opportunities to engage the process are described in this manual. The analysis of OATT transmission facilities below 100kV and not under PJM operational control is led by the Transmission Owner (TO.) This is appropriate since local Transmission Owner operations, maintenance and planning personnel oversee these local systems. These facilities typically provide only local transmission function of interest to the customers in the nearby electrical vicinity. The TO analysis ensures local facilities meet NERC and local reliability criteria. In addition, the local Transmission Owner personnel may also develop recommended modifications to transmission facilities that are not required by PJM reliability, market efficiency or operational performance criteria (the non-criteria based upgrades are called Supplemental RTEP Projects.) The Transmission Owner will initiate all reliability-based and supplemental upgrade requests for facilities not under PJM's control. All such projects will be introduced to the PJM Regional planning process through PJM's TEAC and Subregional RTEP Committees. In this way these TO initiated projects will be subject to the same open, transparent and participatory PJM committee activities as PJM initiated projects (see discussion of TEAC and Subregional RTEP Committee.)

Interconnection planning encompasses generator and merchant transmission requests for Interconnections and rerates as well as requests for long-term firm transmission service. Studies of these transmission requests and any resulting transmission modifications are posted to PJM's website in the project queue area (<http://www.pjm.com/planning/generation-interconnection.aspx>). In addition, any necessary facility modifications are brought to the TEAC for presentation and stakeholder participation. Interconnection planning is discussed in more detail in Manual 14A.

## 1.2 TEAC and Subregional RTEP Committee and Related Activities

The PJM TEAC functions in accordance with its established charter and provisions of Schedule 6 of the Operating Agreement. Additionally, in 2008 PJM began to facilitate more localized planning functions through the Subregional RTEP Committee. The Subregional RTEP Committee, including any local reviews that may be initiated, will follow TEAC procedures and other applicable PJM committee procedures. All PJM stakeholders will be provided with the opportunity for participation in the TEAC and Subregional RTEP Committees and related activities.

The subregional and any related meetings allow more focused and meaningful stakeholder participation and attention to subregional and local transmission issues. RTEP projects are labeled as Regional RTEP Projects and Subregional RTEP Projects, as defined in the Operating Agreement, to make an initial categorization and posting of violations and upgrades that will enable stakeholders to more easily sort through and review issues of interest. Regional RTEP Projects are those transmission expansions or enhancements rated

at voltages 230 kV and above. Subregional RTEP Projects are those rated below 230 kV. This differentiation by voltage between Regional RTEP Projects and Subregional RTEP Projects is made only for administrative convenience.

The Subregional RTEP Committee is responsible for the initial review of Subregional RTEP Projects. PJM will facilitate meetings as necessary for TEAC and Subregional RTEP Committee review and evaluation of reliability and market efficiency reinforcements. The Subregional RTEP Committee will forward all Subregional RTEP Projects to the TEAC. TEAC or the Subregional RTEP Committee, as appropriate will also have the opportunity to provide advice and recommendations regarding the study scope, assumptions and procedures at an initial assumptions setting meeting. This meeting will cover both reliability and market efficiency assumptions, as appropriate. Initially, a minimum of three PJM RTEP subregions will be established: one each for the Mid Atlantic, South, and West subregions of PJM. When a Subregional RTEP Committee meeting is scheduled it is understood that this generally will be implemented as a separate meeting for each subregion. In this way, the TEAC and Subregional RTEP Committees provide a transparent and participatory planning process throughout the RTEP development, from early assumptions-setting stages, through discussion of criteria violations, review of recommendations for alternative solutions, and review and comment on the final RTEP facilities.

All RTO stakeholders can participate in any or all subregional activities on a voluntary basis, with one exception. The Transmission Owners that comprise each of the various subregions must participate in the subregional meeting that includes their area. PJM, with stakeholder input, may initiate additional subregional or local review as may be necessary or beneficial. Local meetings or more localized review occurs in the event that PJM, taking into account stakeholder input, decides that it is appropriate to address issues in a forum other than or in addition to the context of one of the initial subregions. In addition to their participation in the TEAC and Subregional RTEP Committee meetings, stakeholders can also provide written comments on the development of the RTEP. Written comments can be forwarded to RTEP@pjm.com.

There are various categories of facilities that enter the PJM plan through distinct paths, however, each path is transparent and open to all interested stakeholder participation through TEAC and Subregional RTEP Committee processes. All four planning paths to the PJM RTEP; reliability planning, economic planning, interconnection planning, and local Transmission Owner Planning; flow through the TEAC and Subregional RTEP Committee planning process.

PJM Committee review of all RTEP projects, regardless of the path of origin of the project, will occur during the February through August RTEP Stakeholder analysis and review periods (see Exhibit 1.) Stakeholders will be provided all the information necessary for full participation in the discussions and evaluations, including: (1) the criteria and assumptions used as the basis for projects, (2) the procedure to access the study information necessary to participate in the project's evaluation and discussion, (3) a detailed description of the timing, need and justification of the project, (4) a description of the cost and construction responsibility for the project, and (5) a detailed description of the proposed modifications to facilities.

In addition, projects that originate through local Transmission Owner planning will be posted on the PJM web site. This site will include all currently planned transmission owner RTEP projects (including both newly planned Supplemental RTEP projects and Transmission

Owner Initiated projects from past RTEP cycles that are yet to be placed in-service.) This website will provide tracking information about the status of listed projects and planned in-service dates. It will also include information regarding criteria, assumptions and availability of study cases related to local planning.

## 1.3 Planning Assumptions and Model Development

### 1.3.1 Reliability Planning

PJM's planning analyses are based on a consistent set of fundamental assumptions regarding load, generation and transmission built into power flow models. Load assumptions are based on the annual PJM entity load forecast independently developed by PJM (found at <http://www.pjm.com/planning/resource-adequacy-planning/load-forecast-dev-process.aspx>.) This forecast includes the basis for all load level assumptions for planning analyses throughout the 15 year planning horizon. Generation and transmission planning assumptions are embodied in the base case power flow models developed annually by PJM and derived from the Eastern Reliability Assessment Group processes and procedures pursuant to NERC standards MOD-010-0, -011-0, and -012-0. As necessary, PJM updates those models with the most recent data available for its own regional studies. All PJM base power flow and related information are available pursuant to applicable Critical Energy Infrastructure Information, Non-Disclosure and OATT-related requirements (accessible via <http://www.pjm.com/planning/rtep-development/powerflow-cases.aspx> or by contacting the PJM Planning Committee contacts.) Each type of RTEP analysis (e.g., load deliverability, generator deliverability etc.) encompasses its own methodological assumptions as further described throughout the rest of this Manual. Additional details regarding the reliability planning criteria, assumptions, and methods can be found in following sections and this manual's Attachments.

### 1.3.2 Market Efficiency Planning

PJM will perform a market efficiency analysis each year, following the completion of the near-term reliability plan for the region. PJM's market efficiency planning analyses are based on the same starting assumptions applicable to the reliability planning phase of the RTEP development. In addition, key market efficiency input assumptions, used in the projection of future market inefficiencies; include load and energy forecasts for each PJM zone, fuel costs and emissions costs, expected levels of potential new generation and generation retirements and expected levels of demand response. PJM will input its study assumptions into a commercially available market simulation data model that is available to all stakeholders. The data model contains a detailed representation of the Eastern Interconnection power system generation, transmission and load. In addition, the market efficiency analysis of the cost/benefit of potential market efficiency upgrades will also include the discount rate and annual revenue requirement rate. The discount rate is used to determine the present value of the enhancements' annual benefits and annual cost. The annual revenue requirement rate is used to determine the enhancements' annual cost. PJM will finalize the market efficiency analysis input assumptions soon after the development of the PJM load forecast that is generally available approximately in late January. Prior to finalizing, PJM will review the proposed assumptions at the same PJM Subregional RTEP Committee assumptions meetings that address the reliability analysis assumptions, expected to occur in December preceding the year of the annual RTEP cycle. This review will provide the opportunity for stakeholder review of and input to all of the key assumptions

that form the basis of the market efficiency analysis. In this way, PJM will facilitate a comprehensive stakeholder review and input regarding RTEP study assumptions. All final assumptions and analysis parameters will be presented to the TEAC for discussion and review and to the PJM Board for approval.

## 1.4 RTEP Process Key Components

PJM's goal is to ensure electric supply adequacy and to enhance the robustness of energy and capacity markets. Achieving these objectives requires the successful completion of PJM's planning, facility construction and operational and market infrastructure requirements.

Key components of PJM's 15-year transmission planning process discussed in this Manual include:

1. Baseline reliability analyses:

The PJM Transmission System ("PJM System") provides the means for delivering the output of interconnected generators to the load centers in the PJM energy and capacity markets. Baseline reliability analyses ensure the security and adequacy of the Transmission System to serve all existing and projected long term firm transmission use including existing and projected native load growth as well as long term firm transmission service. RTEP baseline analyses include system voltage and thermal analysis, and stability, load deliverability, and generation deliverability testing. These tests variously entail single and multiple contingency testing for violations of established NERC reliability criteria regarding stability, thermal line loadings and voltage limits. Baseline reliability analyses are discussed in more detail in Section 2 and Attachment C.

2. Generation and transmission interconnection analyses:

All entities requesting interconnection of a generating facility (including increases to the capacity of an existing generating unit) or requesting interconnection of a merchant transmission facility within the PJM RTO must do so within PJM's defined interconnection process. In addition to the baseline analyses discussed above, as resources or merchant transmission requests interconnection, deliverability in the local area of the request is restudied and updated. The generation and transmission interconnection process and deliverability testing procedures are discussed in Attachment C and Manual 14A. The evaluation of generation and merchant transmission interconnection requests is codified in the PJM Open Access Transmission Tariff (available on the PJM Web site at [www.pjm.com](http://www.pjm.com)).

3. Market efficiency analyses:

In addition to reliability based analyses PJM also evaluates the economic merit of proposed transmission enhancements. These analyses focus on the economic impacts of security constraints on production cost, congestion charges to load and other econometric measures of market impacts. PJM's market efficiency analyses are discussed in Section 2 of this Manual and Attachment E. PJM development of economic transmission enhancements is also codified under Schedule 6 of the PJM Operating Agreement.

4. Operational performance issue reviews and accompanying analyses:

Maintaining a safe and reliable Transmission System also requires keeping the transmission system equipment in safe, reliable operating condition as well as addressing actual operational needs. On an ongoing basis, PJM operating and planning personnel assess the PJM transmission development needs based on recent actual operations. This may lead to special studies or programs to address actual system conditions that may not be evident through projections and system modeling.

To ensure that system facilities are maintained and operated to acceptable reliability performance levels, PJM has implemented an Aging Infrastructure Initiative to evaluate appropriate spare transformer levels and optimum equipment replacement or upgrade requirements. This initiative, based on a Probability Risk Assessment (PRA) process, is intended to result in a proactive, PJM-wide approach to assess the risk of facility failures and to mitigate operational and market impacts. Section 2 of this manual provides further discussion of the PRA process.

5. The final RTEP Plan:

Based on all of the requirements for firm transmission service on the PJM System, PJM annually develops a Regional Transmission Expansion Plan to meet those requirements on a reliable, economic system development and environmentally acceptable basis. Furthermore, by virtue of its regional scope, the RTEP process assures coordination of expansion plans across multiple transmission owners' systems, permitting the identification of the most effective and efficient expansion plan for the region. The RTEP plan developed through this process is reviewed by PJM's independent Board of Managers who has the final authority for plan's approval and implementation. The following Section 2 describes the PJM RTEP Process analysis.

## 1.5 Planning Criteria

### 1.5.1 Reliability Planning

Stakeholders have the opportunity at a national level through the participatory standards development process of the North American Electric Reliability Corporation (NERC) to influence the industry planning criteria that form the basis of PJM's planning process (found at <http://www.nerc.com/page.php?cid=2>.) NERC regional criteria development, applicable to PJM, is also open to stakeholder input through the open and participatory process of ReliabilityFirst Corporation (found at <https://www.rfirst.org/standards/Pages/StandardsDocuments.aspx>.)

Additionally, regional and local criteria that go beyond and complement the NERC obligations can be created and incorporated into PJM planning through participation in PJM's Planning Committee and other related stakeholder processes (please refer to <http://www.pjm.com/committees/pjm.html>.) In this manner, PJM, as the independent planning authority, avails stakeholders full opportunity to participate in the planning process from assumptions setting to the final plan. The PJM annual regional plan is based on the effective criteria in place at the time of the analyses, including applicable standards and

criteria of the NERC and the applicable regional reliability council<sup>1</sup>, the various Nuclear Plant Licensees' Final Safety Analysis Report grid requirements and the PJM and local Reliability Planning Criteria (Attachment D.) Section 2 details the specific criteria applicable to each transmission planning process study phase. Criteria are comparably applicable to all similarly situated Native Load Customers and other Transmission Customers.

### 1.5.2 Market Efficiency Planning

Market efficiency planning is an evaluation process that results in facilities planned to achieve economic efficiencies rather than an analysis that produces violations measured against criteria. This process compares alternative plans' cost effectiveness in improving transmission efficiency and produces RTEP recommendations from this process. The metrics of economic inefficiency include historic and projected congestion. The measures of historic congestion are gross congestion, unhedgeable congestion, and pro-ratio of auction revenue rights. The measure of projected congestion is based on a market analysis of future system conditions performed with a commercially available security constrained, economic dispatch market analysis tool. This market analysis results in future projections of the congestion and its binding constraint drivers. These congestion measures are posted and available to stakeholders by binding constraint and form the basis for PJM and stakeholder development of remedies. Transmission plans from the reliability analysis or a new plan presented that economically relieves historical or projected congestion are candidates for market efficiency solutions. The successful candidates will be those facilities that pass PJM's threshold test and bright line economic efficiency test. This test specifies that a proposed solution's savings in the sum of the weighted production cost of energy and capacity plus the weighted load cost of energy and capacity (weighted 70%, 30% respectively) must exceed its projected revenue requirements, on a 15 year present worth basis, by at least 25% (the threshold cost/benefit test.) Each of this process' elements, its underlying assumptions and its methods is described in more detail in the accompanying sections of this manual 14B and in Attachment E.

---

<sup>1</sup> The ReliabilityFirst Regional Reliability Corporation (RRC) for the PJM Mid-Atlantic and Western Regions (which replaced the former ECAR, MAAC and MAIN RRCs on January 1, 2006) and the Virginia-Carolinas (VACAR) Area Reliability subregion of the SERC Reliability Corporation for PJM Southern Region.

## Section 2: Regional Transmission Expansion Plan Process

In this section you will find an overview of the PJM Region transmission planning process, covering the following areas:

- Components of PJM's 15-Year planning
- The need and drivers for a regional transmission expansion plan
- Reliability planning overview
- Specific components of reliability planning and the Stakeholder process
- Interconnection request drivers of RTEP
- Cost responsibility for reliability related upgrades
- Market efficiency planning review
- Specific components of market efficiency planning and the Stakeholder process.
- Operational performance driven planning
- Specific components of operational performance driven planning

### 2.1 Transmission Planning = Reliability Planning + Market Efficiency

Effective with the 2006 RTEP, PJM, after stakeholder review and input, expanded its RTEP Process to extend the horizon for consideration of expansion or enhancement projects to fifteen years. This enables planning to anticipate longer lead-time transmission needs on a timely basis.

Fundamentally, the Baseline reliability analysis underlies all planning analyses and recommendations. On this foundation, PJM's annual 15-year planning review now yields a regional plan that encompasses the following:

1. Baseline reliability upgrades, discussed in this Section 2;
2. Generation and transmission interconnection upgrades, discussed in Attachment C and Manual 14A.
3. Market efficiency driven upgrades, discussed in this Section 2.
4. Operational performance issue driven upgrades, discussed in this Section 2.

**Exhibit 1** shows the 24-month planning process used for the 15-year RTEP horizon. This 24-month planning process integrates the upgrades noted above with information transparency, stakeholder input and review and PJM Board of Manager approvals. Activities shown on this diagram and their timing are for illustrative purposes. The actual timeline may vary to some degree to be responsive to the RTEP and stakeholder needs.

The 24-month planning process is made up of two similar 12-month planning cycles to identify and develop shorter lead-time transmission upgrades and one 24-month planning cycle to provide sufficient time for the identification and development of longer lead-time transmission upgrades that may be required to satisfy planning criteria. Consistent with the

requirements of the NERC TPL Reliability Standards the 24-month planning process includes both near-term (years one through five) and long-term (years six through fifteen) assessments of the transmission system as described below.

The first step in the process is to develop the set of assumptions that will be used for the subsequent analyses. These assumptions are vetted with stakeholders at TEAC and Subregional RTEP Committee meetings. A series of power-flow base cases are then developed based on the assumptions. The yearly series of cases include the latest information and assumptions available related to load, resources and transmission topology. A new 5-year base case is developed for near-term baseline reliability analysis. Base cases for retool analyses of years closer than 5-years are developed as required.

In addition to these near-term base cases additional power-flow base cases are developed for long-term planning. These long-term cases are used to evaluate the need for more significant projects requiring a longer time to develop. These longer lead time projects generally provide a more regional benefit. The long-term base case developed at the start of each 24-month planning cycle is based on the system conditions that are expected to exist in 8 years. As noted in Exhibit 1, this 8-year out base case is updated and retooled at the start of the second year of the 24-month planning cycle (i.e. at that point a 7-year out base case), with additional criteria analysis being run to validate the findings from the analysis that was conducted during the first year of the 24-month planning cycle.

**Exhibit 1: 24-Month Planning Cycle**

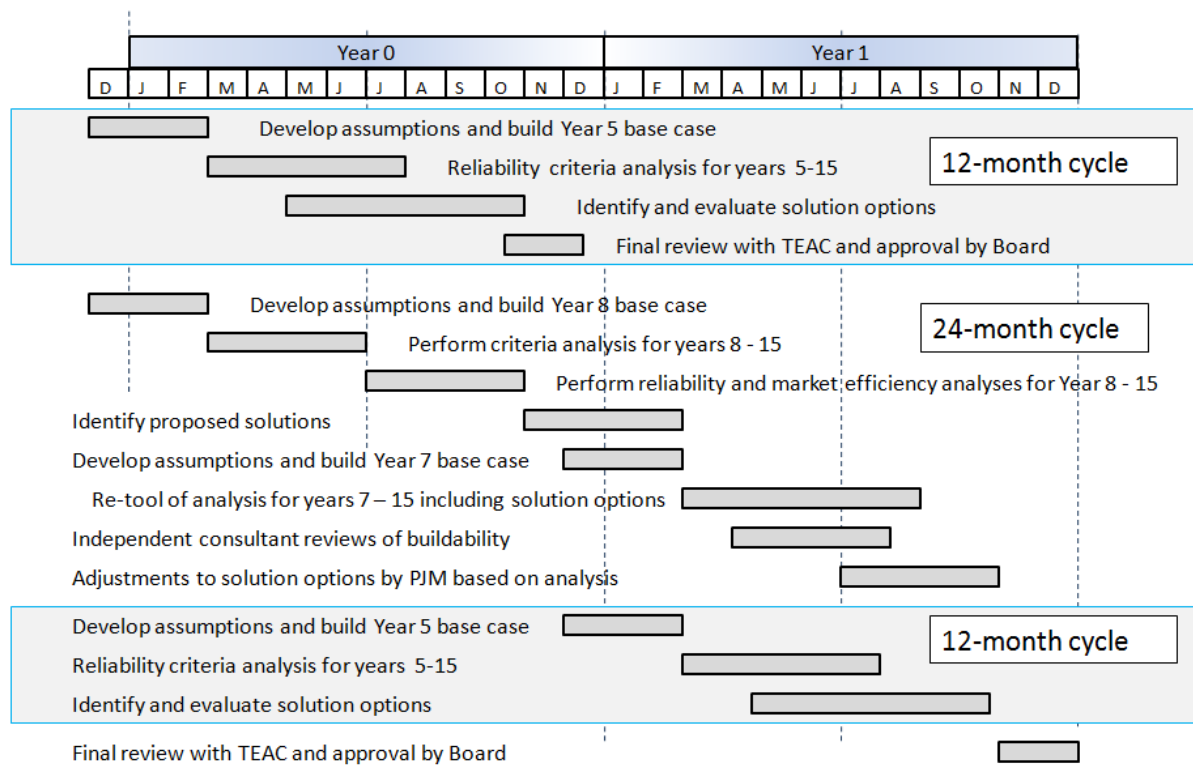

The scope of the near-term baseline analysis that is completed as part of each 12-month planning cycle includes an exhaustive review of applicable reliability planning criteria on all BES facilities as described in section 2.3 of this manual. As noted above, PJM typically performs this near-term analysis on a 5-year out base case. Retool analyses of previous near-term assessments are also completed, as required. Any identified criteria violations are reviewed with stakeholders throughout the planning process. Ultimately, solutions to address the criteria violations are developed, reviewed with the TEAC and/or Sub-regional RTEP Committee as applicable, and submitted to the PJM Board of Managers for approval. Through this planning process, a baseline system without any criteria violations is developed for the near-term (i.e., 5-year baseline). This baseline system, without any criteria violations, is then used for subsequent interconnection queue studies.

Long-term planning is also completed as part of the development of the RTEP to identify solutions to planning criteria violations that require longer lead times to implement. As part of the 24-month planning cycle PJM initially develops an 8-year out base case that is used to evaluate planning criteria for the long-term planning horizon. Long term criteria analysis is completed on this base case during the first year of the 24-month cycle. A combination of a full AC powerflow solution and linear analysis, as described in this manual, is used to determine the loading on facilities for years 8 through 15. Violations and proposed solutions to address them are developed by stakeholders and PJM staff during the first year of the 24-month planning cycle. As shown in Exhibit 2, during the second year of the 24-month planning cycle, the base case used for the long-term analysis during the first year (i.e., now year 7) is updated to reflect the latest assumptions about load, generation, DR, EE, and transmission topology. Long term criteria analysis is completed on this base case during the second year of the 24-month cycle. A combination of a full AC powerflow solution and linear analysis, as described in this manual, is again used to determine the loading on facilities for years 7 through 15. Potential violations identified during the first year are validated and the proposed solutions to address those violations are refined during the second year of the 24-month planning cycle. An independent consultant may be used to develop an independent cost estimate and evaluate the buildability of proposed solutions. Results from these long-term analyses, including potential violations and their solutions, are reviewed with the TEAC throughout the 24-month planning process. Ultimately, any required long-lead time solutions that are identified through this planning process are presented to the PJM Board of Managers for approval.

**Exhibit 2: Base Case Development**

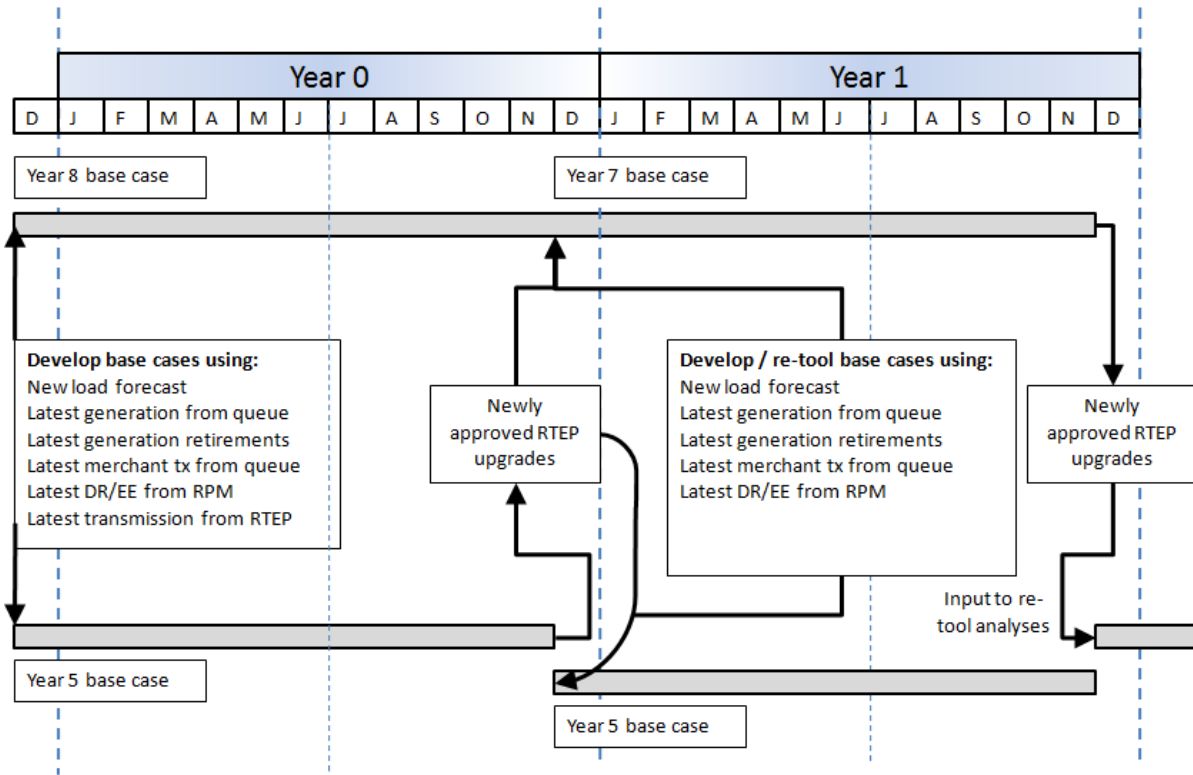

**2.2 The RTEP Process Drivers**

The continuing evolution and growth of PJM’s robust and competitive regional markets rests on a foundation of bulk power system reliability, ensuring PJM’s ongoing ability to meet control area load-serving obligations. It also includes a commitment to enhance the robustness and competitiveness of Energy and Capacity markets by incorporating analysis and development of market efficiency projects. Schedule 6 of the PJM Operating Agreement describes the PJM RTEP process, governing the means by which PJM coordinates the preparation of a plan for the enhancement and expansion of the Transmission Facilities – on a reliable and environmentally sensitive basis and in full consideration of available economic and market efficiency factors and alternatives - in order to meet the demands for firm transmission service in the PJM region. PJM’s FERC-approved RTEP process preserves this foundation through independent analysis and recommendation, supported by broad stakeholder input and approval by an independent RTO Board in order to produce a single RTEP.

The PJM Region transmission planning process is driven by a number of planning perspectives and inputs, including the following:

- ReliabilityFirst Regional Reliability Corporation<sup>2</sup> (RFC) Reliability Assessment – forward-looking assessments performed to assure compliance with NERC and applicable regional reliability corporation

<sup>2</sup> ReliabilityFirst, a new regional reliability corporation under the North American Electric Reliability Corporation (NERC), replaced three existing PJM-related reliability councils (ECAR, MAAC and MAIN) on January 1, 2006.

(ReliabilityFirst or SERC Reliability Corporation) reliability standards, as appropriate.

- SERC Reliability Corporation (SERC) Reliability Assessment
- PJM Annual Report on Operations – an assessment of the previous year’s operational performance to assure that any bulk power system operational conditions which have emerged, e.g., congestion, are adequately considered going forward.
- PJM Load Serving Entity (LSE) capacity plans
- Generator and Transmission Interconnection Requests – submitted by the developers of new generating sources and new Merchant Transmission Facilities, these requests seek interconnection in the PJM Region (or seek needed enhancements as the result of increases in existing generating resources.)
- Transmission Owner and other stakeholder transmission development plans
- Interregional transmission development plans – the transmission expansion plans of those power systems adjoining PJM, and in some cases, beyond.
- Long-term Firm Transmission Service Requests
- Activities under the PJM committee structure especially, the Planning Committee (PC), the Transmission Expansion Advisory Committee (TEAC), the Subregional RTEP Committee, and local groups facilitated by PJM within the TEAC established processes (see section 1 “TEAC, Subregional RTEP Committee, and related planning activities”.)
- PJM Development of Economic Transmission Enhancements based on Economic and Market Efficiency factors
- Operational performance assessments and reviews such as the aging Infrastructure Initiative – a Probabilistic Risk Assessment of equipment that poses significant risk to the Transmission System.

The cumulative effect of these drivers is analyzed through the PJM Region transmission planning process to develop a single RTEP which recommends specific transmission facility enhancements and expansion on a reliable and environmentally sensitive basis and in full consideration of economic and market efficiency analyses. See Attachment B for details of the RTEP – Scope and Procedure.

**NOTE:** The most recent version of the PJM RTEP is available PJM Web site at <http://www.pjm.com/planning/rtep-upgrades-status.aspx>.

These analyses are conducted on a continual basis, reflecting specific new customer needs as they are introduced, but also readjusting as the needs of Transmission Customers and Developers change. One such RTEP baseline regional plan will be developed and approved each year.

**NOTE:** Generation withdrawals have the potential to impact study results for any generation or merchant transmission project that doesn't have an executed ISA.

Generation retirements will not affect the study results for any generation or merchant transmission project that has received an Impact Study Report (i.e., No Retool – the generator retirements are applied at the next baseline update.)

Generation retirements included in interconnection project studies will be those announced as of the date a project enters the interconnection queue.

In this way, the plan continually represents a reliable means to meet the power system requirements of the various Transmission Customers and Interconnection Customers in a fully integrated fashion, at the same time preserving the rights of all parties with respect to the Transmission System. The assurance of a reliable Transmission System and the protection of the Transmission Customer/Developer rights with respect to that system coupled with the timely provision of information to stakeholders are the foundation principles of the PJM transmission planning process.

The PJM Region transmission planning process also establishes the cost responsibility for the following types of facility enhancements as defined in the PJM Tariff:

- Attachment Facilities
- Direct Assignment Facilities
- Network Upgrades (Direct and Non-direct)
- Local Upgrades
- Merchant Network Upgrades

Each RTEP encompasses a range of proposed power system enhancements: circuit breaker replacements to accommodate increased current interrupting duty cycles; new capacitors to increase reactive power support; new lines, line reconductoring and new transformers to accommodate increased power flows; and, other circuit reconfigurations to accommodate power system changes as revealed by the drivers discussed above.

Requests for interconnection of new generators or transmission facilities, while not the sole drivers of the PJM Region transmission planning process, are a key component of the RTEP. Analyzing these requests has required adoption of an approach that establishes baseline system improvements driven by known inputs, followed by separate queue-defined, cluster-based impact study analyses. Overall, PJM's RTEP process – under a FERC-approved RTO model – encompasses independent analysis, recommendation and approval to ensure that facility enhancements and cost responsibilities can be identified in a fair and non-discriminatory manner, free of any market sector's influence. All PJM market participants can be assured that the proposed RTEP was created on a level playing field.

## 2.3 RTEP Reliability Planning

### 2.3.1 Establishing a Baseline

In order to establish a reference point for the annual development of the RTEP reliability analyses a 'baseline' analysis of system adequacy and security is necessary. The purpose of this analysis is threefold:

- To identify areas where the system, as planned, is not in compliance with applicable NERC and the applicable regional reliability council (ReliabilityFirst or SERC) standards, Nuclear Plant Licensee requirements and PJM reliability standards including equipment replacement and/or upgrade requirements under PJM's Aging Infrastructure Initiative. The baseline system is analyzed using the same criteria and analysis methods that are used for assessing the impact of proposed new interconnection projects. This ensures that the need for system enhancements due to baseline system requirements and those enhancements due to new projects are determined in a consistent and equitable manner.
- To develop and recommend facility enhancement plans, including cost estimates and estimated in-service dates, to bring those areas into compliance.
- To establish the baseline facilities and costs for system reliability. This forms the baseline for determining facilities and expansion costs for interconnections to the Transmission System that cause the need for facilities beyond those required for system reliability.

The system as planned to accommodate forecast demand, committed resources, and commitments for firm transmission service for a specified time frame is tested for compliance with NERC and the applicable regional reliability council (ReliabilityFirst or SERC) standards, Nuclear Plant Licensee requirements, PJM Reliability Standards and PJM design standards. Areas not in compliance with the standards are identified and enhancement plans to achieve compliance are developed.

The 'baseline' analysis and the resulting expansion plans serve as the base system for conducting Feasibility Studies for all proposed generation and/or merchant transmission facility interconnection projects and subsequent System Impact Studies.

### 2.3.2 Baseline Reliability Analysis

PJM's most fundamental responsibility is to plan and operate a safe and reliable Transmission System that serves all long term firm transmission uses on a comparable and not unduly discriminatory basis. This responsibility is addressed by PJM RTEP reliability planning. Reliability planning is a series of detailed analyses that ensure reliability under the most stringent of the applicable NERC, PJM or local criteria. To accomplish this each year, the RTEP cycle extends and updates the transmission expansion plan with a 15 year review. This cycle entails several steps. The following sections describe each step's assumptions, process and criteria. Attachments A through F of this manual add essential details of various aspects of the reliability planning process.

Reliability planning involves a near-term and a longer term review. The near term analysis is applicable for the current year through the current year plus 5. The longer term view is applicable for the current year plus 6 through plus 15. Each review entails multiple analysis steps subject to the specific criteria that depend on the specific facilities and the type of analysis being performed.

The analysis is initiated in December prior to each annual cycle and concludes with review by the TEAC and approval by the PJM Board about October (TEAC and the PJM Board are appraised regularly throughout the process and partial reviews and approvals of the plan may occur throughout the year.) The TEAC, Subregional RTEP and PJM Planning Committee roles in the development of the reliability portion of the RTEP are described in Schedule 6 of the PJM Operating Agreement.

### **2.3.3 Near-Term Reliability Review**

The near-term reliability review (current year plus 5) provides reinforcement for criteria violations that are revealed by applicable contingency analysis. Limits used in the analysis are established consistent with the requirements of NERC standards FAC-010 and FAC-014. The methodology used to determine system operating limits is included in Attachment-F of this manual. System conditions revealed as near violations will be monitored and remedied as needed in the following year near-term analysis. Violations that occur in many deliverability areas or severe violations in any one area will be referred to the long term analysis for added study of possible more robust system enhancement. PJM annually conducts this detailed review of the current year plus 5. Each year of the period through the current year plus 4 (“in-close” years) has been the subject of previous years’ detailed analyses. In addition, for each of these “in-close” years, PJM updates and issues addendum to address changes as necessary throughout the year. For example planned generation modifications or changes in transmission topology can trigger restudy and the issuance of a baseline addendum. This is referred to as a “retool” study. (For example generators that drop from the Q’s cause restudy and an addendum to be issued for affected baseline analyses.) Also each year during the establishment of the assumptions for the new annual baseline analysis, current updated views of load, transmission topology, installed generation, and generation and transmission maintenance are assessed for the “in-close” range of years to validate the continued applicability of each of the “in-close” baseline analyses and resulting upgrades (including any addendum.) Adjustments in the “in-close” analyses are performed as deemed necessary by PJM. PJM, therefore, annually verifies the continued need for or modification of past recommended upgrades through its retool studies, reassessment of current conditions and any needed adjustments to analyses. All criteria thermal and voltage violations resulting from the near term analyses are produced using solved AC power flow solutions. Initial massive contingency screening may use DC power flow solution techniques.

There are seven steps in an annual near-term reliability review. They are:

- Develop a Reference System Power Flow Case
- Baseline Thermal
- Baseline Voltage
- Load Deliverability - Thermal
- Load Deliverability - Voltage

- Generation Deliverability - Thermal
- Baseline Stability

These reliability related steps are followed by a scenario analysis that ensures the robustness of the plan by looking at impacts of variations in key parameters selected by PJM. Each of these steps are described in more detail in the following material.

### **2.3.4 Reference System Power Flow Case**

The reference power flow case and the analysis techniques comprise the full set of analysis assumptions and parameters for reliability analysis. Each case is developed from the most recent set of Eastern Reliability Assessment Group system models. PJM transmission planning revises this model as needed to incorporate all of the current system parameters and assumptions. These assumptions include current loads, installed generating capacity, transmission and generation maintenance, system topology, and firm transactions. These assumptions will be provided to and reviewed by the Subregional RTEP Committee. The subregional modeling review and modeling assumptions meeting provides the opportunity for stakeholders to review and provide input to the development of the reference power system models used to perform the reliability analyses.

The results of any locational capacity market auction(s) will be used to help determine the amount and location of generation or demand side resources to be included in the reliability modeling. Generation or demand side resources that are cleared in any locational capacity market auction will be included in the reliability modeling, and generation or demand side resources that either do not bid or do not clear in any locational capacity market auction will not be included in the reliability modeling. All such modeling described here will comport with the capacity construct provisions approved by the FERC.

Subsequent to the subregional stakeholder modeling reviews facilitated by PJM, PJM will develop the final set of reliability assumptions to be presented to TEAC for review and comment, after which PJM will finalize the reliability review reference power flow. This model is expected to be available in early January of each year to interested stakeholders, subject to applicable confidentiality and CEII requirements, to facilitate their review of the results of the reliability modeling analyses.

### **2.3.5 Contingency Definitions**

Contingency definitions used in RTEP analysis are the same as applicable NERC TPL contingency definitions. Where the physical design of connections or breaker arrangements results in the outage of more than the faulted equipment when a fault is cleared, the additional facilities are also taken out of service in the contingency definition. For example, if a transformer is tapped off a line without a breaker, both the line and transformer are removed from service as a single contingency event.

Contingency definitions for double circuit tower line outages shall include any two adjacent (vertically or horizontally) circuits on a common structure, but shall exclude circuits that share a common structure for one mile or less. The loss of more than two circuits on a common structure constitutes a NERC extreme event.

### **2.3.6 Baseline Thermal Analysis**

Baseline thermal analysis is a thorough analysis of the reference power flow to ensure thermal adequacy based on normal (applicable to system normal conditions prior to contingencies) and emergency (applicable after the occurrence of a contingency) thermal ratings specific to the Transmission Owner facilities being examined. It is based on a 50/50 load forecast from the latest available PJM Load Forecast Report (50% probability that the actual load is higher or lower than the projected load.) It encompasses an exhaustive analysis of all NERC category A, B and C events and the most critical common mode outages. Final results are supported with AC power flow solutions. The PJM Load Forecast uses a 50/50 distribution minus Energy Efficiency. Demand Response is not considered in the Load Forecast.

For normal conditions (NERC category A), all facilities shall be loaded within their normal thermal ratings. For each single contingency (NERC Category B), all facilities shall be loaded within their emergency thermal ratings. After each single contingency and allowing phase shifter, re-dispatch and topology changes to be made, post-contingency loadings of all facilities shall be within their applicable normal thermal ratings.

For the more severe NERC category C contingencies, along with only transformer tap and switched shunt adjustments enabled, post-contingency loadings of all facilities shall be within their applicable emergency thermal ratings as required by the PJM or the Transmission Owner planning criteria. The study procedure for the NERC category C.3 contingencies (N-1-1) is described in detail in section 2.3.8.

### **2.3.7 Baseline Voltage Analysis**

Baseline voltage analysis parallels the thermal analysis. It uses the same power flow and examines voltage criteria for all the same NERC category A, B, and C events. Also, voltage criteria are examined for compliance. PJM examines system performance for both a voltage drop criteria (where applicable) and an absolute voltage criteria. The voltage drop is calculated as the decrease in bus voltage from the initial steady state power flow to the post-contingency power flow. The post-contingency power flow is solved with generators holding a local generator bus voltage to a pre-contingency level consistent with specific Transmission Owner specifications. In most instances this is the pre-contingency generator bus voltage. Additionally, all phase shifters, transformer taps, switched shunts, and DC lines are locked for the post-contingency solution. SVC's are allowed to regulate and fast switched capacitors are enabled.

The absolute voltage criteria is examined for the same contingency set by allowing transformer taps, switched shunts and SVC's to regulate, locking phase shifters and allowing generators to hold steady state voltage criteria (generally an agreed upon voltage on the high voltage bus at the generator location.)

In all instances, specific Transmission Owner voltage criteria are observed. All violations are recorded and reported and tentative solutions will be developed. These study results will be presented to and reviewed with stakeholders.

### 2.3.8 NERC Category C3 “N-1-1” Analysis

#### Purpose:

N-1-1 studies are conducted as part of the annual RTEP to determine if all monitored facilities can be operated:

- Within normal thermal and voltage limits after N-1 (single) contingency assuming re-dispatch and system adjustments, and
- Within the applicable emergency thermal ratings and voltage limits after an additional single contingency (N-1-1) condition.

All violations of the applicable thermal ratings are recorded and reported and tentative solutions will be developed. These study results will be presented to and reviewed with stakeholders.

#### Model:

Annually, the N-1-1 study is conducted on a 50/50 non-diversified summer peak case. The case building details are defined in Attachment C (C7 3.0 Step 1: Develop Base Case). Non-firm Merchant Transmission withdrawals can be removed. All BES facilities in PJM and ties to PJM will be monitored. Areas of the system that become radial post-contingency will be excluded from monitoring, with the following exceptions

- If the radial system contains greater than 300 MW of load, or
- Specific local TO Planning Criteria require that it be monitored.

#### Contingencies considered:

- All BES single contingencies as defined in NERC category C.3 as well as lower voltage facilities that are monitored by PJM Operations will be included in the assessment. Non-BES contingencies, defined by Transmission Owners, need to be included to check for greater than 300 MW load loss. Non-BES facilities that are included in the assessment will also have corresponding contingencies defined.

#### AC Solution Options in the PSS/E program:

- For the first single contingency (N-1 Condition) and to ensure the system remains within emergency thermal ratings
  - Transformer tap adjustment enabled
  - Switched shunt adjustment enabled
- After the first single contingency (N-1 Condition) and to return the system back within normal thermal ratings
  - Phase shifter adjustment enabled
  - System re-dispatched
  - Topology changes implemented
- For the second single contingency (N-1-1 Condition) – Voltage Drop Test (if applicable)

- Transformer tap adjustment disabled
- Phase shifters locked to control angle, not flow
- Switched shunt adjustment disabled except for fast switched capacitors
- Generators are set to regulate their terminal bus
- SVC's are allowed to regulate
- Automatic shunt adjustment disabled
- For the second single contingency (N-1-1 Condition) – Thermal and Voltage Magnitude Test
  - Transformer tap adjustment enabled
  - Phase shifters locked to control angle, not flow
  - Switched shunt adjustment enabled
  - Automatic shunt adjustment enabled

#### PJM NERC Category C3 “N-1-1” Methodology:

##### Thermal Test Methodology:

The PJM NERC Category C3 “N-1-1” Analysis will test the outage of every single contingency (N-1 condition)

1. The first step of the test is to ensure that post-contingency loadings of all facilities shall be within their emergency thermal ratings immediately following the first N-1 contingency
2. The second step of the test is to ensure that post contingency loadings of all facilities shall be within their normal thermal ratings after the first N-1 contingency and subsequent re-dispatch and system adjustments. Allowable system adjustments include generation dispatch, phase shifter adjustment, system reconfiguration and load throwover.
3. The third step is to take the second N-1-1 contingency. Every second N-1-1 contingency is taken on every optimized N-1 scenario case to model the N-1-1 condition. After the second N-1-1 contingency, the thermal loading of any monitored facility that is above the applicable emergency thermal rating (long-term or short-term) is considered a reliability criteria violation and a mitigation plan will be needed.

##### Voltage Drop Test Methodology:

The N-1-1 Voltage Drop Test procedure follows a similar method as the thermal test method, except all monitored facilities are monitored for the emergency voltage drop limit after the second contingency (N-1-1 condition.) The calculation of voltage drop is defined in section 2.3.7.

##### Voltage Magnitude Test:

The N-1-1 Voltage Magnitude Test procedure follows a similar method as the thermal test method, except all monitored facilities are monitored for the emergency low limit after the second contingency (N-1-1 condition.)

Voltage Collapse:

Voltage collapse is considered to be a severe reliability violation, and consequently each N-1-1 condition that exhibits voltage collapse needs to be investigated, validated, and resolved with remedial actions, or network upgrades.

System Adjustments:

Allowable System Adjustments following the first contingency (N-1 condition):

- Application of all effective actions and emergency procedures, with the exception of load shedding
- Redispatch using only PJM generators with capacity rights during the generation redispatch process
- Application of a PJM pool-wide generation availability rate during generator re-dispatch to ensure that the re-dispatch is statistically possible
- Un-faulted facilities in multiple facility outages may be restored
- Manual system switching and re-configuration
  - Opening of transmission facilities
    - Including bus-ties
  - Closing of non-faulted transmission facilities
    - Including bus-ties
- Adjustment of Static Var Compensators (SVCs)
- Phase shifter adjustment
- Wind, solar, and other variable resources will be dispatchable up to their capacity delivery rights if they back off simulated facility loadings.
- The rest of resources can be either off line or dispatched between  $P_{min}$  and  $(1 - \text{PJM generator average outage rate}) * P_{max}$

Allowable System Adjustments following the second contingency (N-1-1 condition):

No manual system adjustments permitted

### **2.3.9 Load Deliverability Analysis**

The load deliverability tests are a unique set of analyses designed to ensure that the Transmission System provides a comparable transmission function throughout the system. These tests ensure that the Transmission System is adequate to deliver each load area's requirements from the aggregate of system generation. The tests develop an "expected value" of loading after testing an extensive array of probabilistic dispatches to determine thermal limits. A deterministic dispatch method is used to create imports for the voltage criteria test. The Transmission System reliability criterion used is 1 event of failure in 25 years. This is intended to design transmission so that it is not more limiting than the generation system which is planned to a reliability criterion of 1 failure event in 10 years.

Each load areas' deliverability target transfer level to achieve the transmission reliability criterion is separately developed using a probabilistic modeling of the load and generation system. The load deliverability tests described here measure the design transfer level

supported by the Transmission System for comparison to the target transfer level. Transmission upgrades are specified by PJM to achieve the target transfer level as necessary. Details of the load deliverability procedure can be found in Attachment C.

### Thermal

This test examines the deliverability under the stressed conditions of a 90/10 summer load forecast. That is, a forecast that only has a 10% chance of being exceeded. The transfer limit to the load is determined for system normal and all single contingencies (NERC category A and B criteria) under ten thousand load study area dispatches with calculated probabilities of occurrence. The dispatches are developed randomly based on the availability data for each generating unit. This results in an expected value of system transfer capability that is compared to the target level to determine system adequacy. As with all thermal transmission tests applied by PJM the applicable Transmission Owner normal and emergency ratings are applied. The steady state and single contingency power flows are solved consistent with the similar solutions described for the baseline thermal analyses.

### Voltage

This testing procedure is similar to the thermal load deliverability test except that voltage criteria are evaluated and that a deterministic dispatch procedure is used to increase study area imports. The voltage tests and criteria are the same as those performed for the baseline voltage analyses.

## **2.3.10 Generation Deliverability Analysis**

The generator deliverability test for the reliability analysis ensures that, consistent with the load deliverability single contingency testing procedure, the Transmission System is capable of delivering the aggregate system generating capacity at peak load with all firm transmission service modeled. The procedure ensures sufficient transmission capability in all areas of the system to export an amount of generation capacity at least equal to the amount of certified capacity resources in each “area”. Areas, as referred to in the generation deliverability test, are unique to each study and depend on the electrical system characteristics that may limit transfer of capacity resources. For generator deliverability areas are defined with respect to each transmission element that may limit transfer of the aggregate of certified installed generating capacity. The cluster of generators with significant impacts on the potentially limiting element is the “area” for that element. The starting point power flow is the same power flow case set up for the baseline analysis. Thus the same baseline load and ratings criteria apply. The flowgates ultimately used in the light load reliability analysis are determined by running all contingencies maintained by PJM planning and monitoring all PJM market monitored facilities and all BES facilities. As already mentioned the same contingencies used for load deliverability apply and the same single contingency power flow solution techniques also apply. Details of the generation deliverability procedure can be found in Attachment C.

One additional step is applied after generation deliverability is ensured consistent with the load deliverability tests. The additional step is required by system reliability criteria that call for adequate and secure transmission during certain NERC category C common mode outages. The procedure mirrors the generator deliverability procedure with somewhat lower deliverability requirements consistent with the increased severity of the contingencies.

The details of the generator deliverability procedure including methods of creating the study dispatch can be found in Attachment C.

### **2.3.11 Light Load Reliability Analysis**

The light load reliability analysis ensures that the Transmission System is capable of delivering the system generating capacity at light load. The 50% of 50/50 summer peak demand level was chosen as being representative of an average light load condition. The system generating capability modeling assumption for this analysis is that the generation modeled reflects generation by fuel class that historically operates during the light load demand level.

The starting point power flow is the same power flow case set up for the baseline analysis, with adjustment to the model for the light load demand level, interchange, and accompanying generation dispatch. The PJM portion of the model is adjusted as well as areas surrounding PJM that impact loadings on facilities in PJM. Interchange levels for the various PJM zones will reflect a statistical average of typical previous years interchange values for off-peak hours. Load level, interchange, and generation dispatch for non-PJM areas impacting PJM facilities are based on statistical averages for previous off-peak periods. Thus the same baseline network model and criteria apply. The flowgates ultimately used in the light load reliability analysis are determined by running all contingencies maintained by PJM planning and monitoring all PJM market monitored facilities and all BES facilities. The contingencies used for light load reliability analysis will include NERC TPL category B and category C, with the exception of the C3 “N-1-1” criteria. NERC TPL Category A, normal system conditions will also be studied. All BES facilities and all non-BES facilities in the PJM real-time congestion management control facility list are monitored. The same single contingency power flow solution techniques also apply. Details of the light load reliability analysis procedure, including methods of creating the study dispatch, can be found in Attachment D.1.

### **2.3.12 Baseline Stability Analysis**

PJM ensures generator and system stability during its interconnection studies for each new generator. In addition, PJM annually performs stability analysis for approximately one third of the existing generators on the system. Analysis is performed on the RTEP baseline stability cases. These analyses ensure the system is transiently stable and that all system oscillations display positive damping with damping ratio consistent with section G.2.2. Generator stability studies are performed for critical system conditions, which include light load and peak load for three phase faults with normal clearing plus single line to ground faults with delayed clearing. Also, specific Transmission Owner designated faults are examined for plants on their respective systems.

Finally, PJM will initiate special stability studies on an as needed basis. The trigger for such special studies commonly includes but is not limited to conditions arising from operational performance reviews or major equipment outages.

### **2.3.13 Long Term Reliability Review**

The PJM RTEP reliability review process examines the longer term planning horizon using a current year plus 15 power flow model and a current year plus 10 power flow model. Assumptions and model development regarding this longer term view will be presented and

reviewed and stakeholder input will be considered in the same process used for the near-term review. The longer term view of system reliability is subject to increased uncertainty due to the increased likelihood of changes in the analysis as time progresses. The purpose of the long term review is to anticipate system trends which may require longer lead time solutions. This enables PJM to take appropriate action when system issues may require initiation during the near term horizon in anticipation of potential violations in the longer term. System issues uncovered that are amenable to shorter lead time remedies will be addressed as they enter into the near-term horizon.

#### Current Year Plus 15 Analysis

The Longer term reliability review involving single and multiple contingency analyses is conducted to detect system conditions which may need a solution with a lead-time to operation exceeding five years. Two processes will be used as indicators to determine the need for contingency analysis in the longer term horizon. The first is a review of the near-term results to detect violations that occur for multiple deliverability areas or multiple or severe violations clustered in a one area of the system. This review may suggest larger projects to collectively address groups of violations. The second is a thermal analysis including double circuit towerline outages at voltages exceeding 100 kV performed on the current year plus fifteen system. All of the current year plus fifteen results produced will be reviewed to determine if any issues may require longer lead time solutions. If so such solutions will be determined and considered for inclusion in RTEP.

This evaluation of the need for longer lead time solutions considers that the NERC category C results may employ load shedding and/or curtailment of firm transactions to ease potential violations. Also this review considers that the current year plus fifteen planning horizon exceeds the required NERC planning horizon. The main effect of this extension to 15 years is to examine a load level that is significantly higher than the base forecast year-ten planning load level. This year fifteen analysis, therefore, captures the equivalent (in a 10-year horizon) of a higher load forecast plus weather sensitivity. To the extent that this long term reliability thermal review indicates marginal system conditions that may require a longer lead time solution, PJM will undertake additional longer term analyses as may be needed.

The long term deliverability analyses follow a similar pattern to the near-term load and generation deliverability analyses. The long term, however, relies solely on linear DC analysis whereas all near term violations result from analysis solutions that rely on the full AC power flow. The load deliverability case is set up for a 90/10 load level and the generation deliverability case is set up for a 50/50 load level. Generation dispatches are determined consistent with the methods for the near term analyses. The analysis for the longer term horizon evaluates all NERC category A and B single contingencies against the same normal and emergency thermal ratings criteria used for the near term (subject to any upgrades that may be applicable for the longer term.)

#### Reactive Analysis

In addition, the longer term review includes a current year plus 10 reactive analysis. This focuses on contingencies involving facilities above 200 kV in areas where the preceding year-15 analysis uncovered thermal violations. Areas experiencing thermal violations that also show earlier reactive deficiencies will be reviewed for possible acceleration of any longer lead time thermal solutions that were suggested by the year-15 analysis. This analysis, as necessary from year to year, will also consider long-term upgrade sensitivity to key variables such as load power factor delivered from the Transmission System or heavy

transfers. If uncovered violations are insufficient to justify acceleration of upgrades and are all amenable to shorter lead-time upgrades, then the violations will continue to be monitored in future RTEP analyses.

### **2.3.14 Stakeholder review of and input to Reliability Planning**

RTEP reliability planning, through the operation of the TEAC and Subregional RTEP Committees, provides interested parties with the opportunity to review and provide meaningful and timely input to all phases of the reliability planning analyses. This section extends the Section 1 discussion of the TEAC and Subregional RTEP Committee process specifically as it relates to reliability planning. Exhibit 1 shows the workflow and timing for the reliability planning process steps. PJM anticipates at least two Subregional RTEP Committee reliability reviews. The initial subregional meeting will present and address reliability study assumptions and parameters. The second meeting will provide the opportunity for stakeholder comment and input on criteria violations and presentations of alternative remedies to identified violations. Between the two meetings PJM will provide feedback on interim study progress sufficient to enable stakeholder preparation for the second set of subregional meetings. Additional subregional meetings will be facilitated as PJM determines is necessary for adequate input and review. The relative timing of the TEAC and subregional activities are illustrated in Exhibit 1.

#### Subregional RTEP Committee initial assumptions meeting

This meeting is expected to occur in **December** of each year in preparation for the upcoming annual RTEP review. Prior to the meeting PJM will post its anticipated inputs and assumptions to enable stakeholder review and preparation for the meeting. At the meeting PJM will present the assumptions for discussion and input by all interested parties. Subsequent to this meeting stakeholders will have additional opportunity to provide input to PJM in preparation for the next TEAC meeting, at which PJM will present the final reliability assumptions for TEAC review. Although the initial Subregional assumptions meeting will discuss anticipated assumptions for both the reliability and market efficiency phase of the RTEP, The final TEAC review of each will likely occur at separate TEAC meetings (see also the market efficiency discussion following.) The TEAC endorsement of final RTEP reliability assumptions is expected to occur in early **January**.

#### PJM development of criteria violations and stakeholder participation

After the TEAC endorsement of PJM's RTEP analysis assumptions, PJM will finalize its reference system power flow which is the starting point of its series of reliability analyses. This power flow is available to stakeholders subject to applicable confidentiality and CEII requirements. PJM will perform its series of detailed RTEP reliability analyses encompassing the 15-year planning horizon. Details of the methods and procedures for the reliability analyses can be found elsewhere in this Manual 14B and its attachments. The five-year and longer time-frame criteria violations will be posted for review, evaluation and development of remedy alternatives by all interested parties. The PJM production of the reliability analysis raw results is expected to occur about **January through July** of each year. Posting of the results and stakeholder review and consideration of alternative remedies is expected to occur about **February through August** of each year. PJM will post TO and other stakeholder alternative upgrade remedies made available throughout this process. Throughout this time frame, TEAC typically has monthly or more frequent regularly scheduled meetings. PJM will periodically apprise TEAC of the progress of the violations

identification and production of upgrade alternatives. Stakeholders may use these meetings to raise and discuss issues found in their reviews. Depending on the issues raised and input from stakeholders PJM may facilitate Subregional RTEP Committee meetings instead of or in addition to a scheduled TEAC meeting. These subregional meetings are intended for more focused review of subregional violations and alternative solutions.

#### Subregional RTEP Committee criteria violations and upgrade alternative meeting

This meeting is expected to occur, as may be necessary in various subregions, in the **July / August** timeframe each year. If a subregional meeting is unnecessary, the regularly scheduled TEAC meetings will provide the opportunity for that subregion's participants open discussion of violations and upgrades. In any event, all regional and subregional projects will be appropriately presented and reviewed at a TEAC meeting. Prior to a subregional violations and upgrade meeting, PJM will post the upgrade solutions that it proposes to remedy the identified criteria violations. At this subregional meeting PJM will present the reliability upgrades of specific violations and alternative upgrades as may be appropriate. By this Subregional RTEP Committee meeting, interested parties will have had the opportunity for ongoing participation in the **February through August** process of violation review and solution identification along with PJM and Transmission Owners. This subregional criteria violations and upgrade meeting is the forum for a final open discussion of the subregional reviews which have been occurring, prior to presentation to TEAC.

#### PJM TEAC Committee RTEP review

PJM expects that about **August** of each year, the final RTEP upgrade facilities will be available for presentation, review and endorsement at a scheduled TEAC meeting. PJM will post its recommendations of RTEP upgrades for identified violations as early as possible in the month prior to the TEAC meeting at which the final RTEP facilities will be reviewed (see [RTEP@pjm.com](mailto:RTEP@pjm.com)). This posting will distinguish facilities that are deemed Supplemental RTEP Projects. After the TEAC RTEP review meeting, there will be about a month of additional time for final written comments on the proposed RTEP facilities, after which the PJM Board will consider the final RTEP plan excluding Supplemental Projects for approval.

## **2.4 RTEP integrates Baseline Assumptions, Reliability Upgrades and Request Evaluations**

PJM's robust energy market has attracted numerous requests from generator and transmission developers for interconnections with the Transmission System. These generator and transmission Interconnection Requests constitute a significant driver of regional transmission expansion needs. This subsection discusses this driver in the context of the RTEP preparation. Details of this process are contained in Manual 14A.

Requests for Long Term Firm Transmission Service and generator deactivations are other types of request that are evaluated and incorporated into RTEP.

Demand Response (DR) can be a load response solution to the need for transmission upgrades. DR solutions enter the PJM process in the Reliability Pricing Model (RPM) through the associated base residual and incremental auctions. The DR cleared in the auction is included in the assumptions for RTEP development and physically modeled in the baseline power flows. In this manner, load can mitigate or delay the need for RTEP upgrades.

The RTEP process baseline analyses include previously processed generators and transmission modifications as starting point assumptions. The current year RTEP evaluations performed on this baseline case are incremental to the baseline and establish a “revised” baseline for the year of the annual RTEP analysis. This revised baseline forms the starting case for the reviews of new interconnection requests. The new interconnection request analyses result in system modifications beyond RTEP upgrades that are caused by each interconnection request. New interconnection request evaluations also include a review of their effects on newly approved RTEP upgrades that are not yet committed to construction. If previously identified RTEP upgrades can be delayed because of a new interconnection request, the projects responsible for the upgrade deferrals will be credited for the benefits of the delayed need for the upgrades.

The RTEP integrates reliability upgrades, interconnection request upgrades and plan modifications and DR effects into a single process that accounts for the mutual interaction of the various market forces. In this way, transmission upgrades, interconnection requests and DR receive comparable treatment with respect to their opportunity to relieve transmission constraints.

Timing of Long-Term Firm Transmission Service Requests, and Generation and Transmission Interconnection Requests are based on the business needs of the party requesting the service. Such Requests, therefore, enter the RTEP planning process throughout the RTEP planning year. Expansion plans that result from these individual project evaluations are incorporated into the RTEP after the system impact study stage. In addition, if needed to satisfy assumed planning reserve requirements for future planning year analyses, queue generators in earlier stages of the queue process may also be included. Only the queue generators with completed signed Interconnection Service Agreements, however, are allowed to be used to alleviate constraints.

This manual contains the details regarding the RTEP reliability planning process procedures. Refer to the introductory Manual 14 for references to the details associated with other elements of RTEP including the request and RPM processes.

## **2.5 RTEP Cost Responsibility for Required Enhancements**

The RTEP encompasses two types of enhancements: Network Reinforcements and Direct Connection Attachment Facilities. Network Reinforcements can be required in order to accommodate the interconnection of a merchant project (generation or transmission) or to eliminate a Baseline problem as a result of system changes such as load growth, known transmission owner facility additions, etc. Merchant project driven upgrades are addressed in Manual 14A. The cost responsibility for each baseline-revealed Network Reinforcement is borne by transmission owners based on the contribution to the need for the network reinforcement. Such costs are recoverable by each transmission owner through FERC-filed transmission service rates. Network reinforcements may also be proposed by PJM to mitigate unhedgeable congestion. Allocation procedures for Baseline and Market Efficiency upgrades are discussed in Attachment A.

Overall, the RTEP is best understood from the perspective of the studies that revealed the recommended Plan enhancements. To that end, the Baseline Analysis and Impact Studies identify the enhancements required to meet defined NERC and applicable regional reliability council (Reliability First or VACAR/SERC) standards, Nuclear Plant Licensee requirements and PJM reliability standards.

## 2.6 RTEP Market Efficiency Planning

Market efficiency analysis is performed as part of the overall PJM Regional Transmission Expansion Planning (RTEP) process to accomplish the following two objectives:

1. Determine which reliability upgrades, if any, have an economic benefit if accelerated.
2. Identify new transmission upgrades that may result in economic benefits.

PJM will perform a market efficiency analysis each year, following the availability of the appropriate updated RTEP power flow resulting from the reliability analysis process. As a result, there is a mechanism in place for regularly identifying transmission enhancements or expansions that will relieve transmission reliability violations that also have an economic impact. Constraints that have an economic impact include, but are not limited to, constraints that cause: (1) significant historical gross congestion; (2) significant historical unhedgeable congestion; (3) pro-ration of Stage 1B ARR; or (4) significant future congestion as forecast in the market efficiency analysis.

In the market efficiency analysis, PJM will compare the costs and benefits of the economic-based transmission improvements. To calculate the benefits of these potential economic-based enhancements, PJM will perform and compare market simulations with and without the proposed accelerated reliability-based enhancements or the newly proposed economic-based enhancements for selected future years within the planning horizon of the RTEP. The relative benefits and costs of the economic-based enhancement or expansion must meet the benefit/cost ratio threshold test to be included in the RTEP recommended to the PJM Board of Managers for approval (This test and its implementation is described in detail in Attachment E.) PJM will also consider potential individual plans meeting objectives 1 or 2 resulting from the analyses of the posted congestion data by all stakeholders. PJM will present all the RTEP market efficiency enhancements to the TEAC Committee for review, comment and endorsement. Subsequent to TEAC review, PJM will address the TEAC review and present the final RTEP market efficiency plan to the PJM Board, along with the advice, comments, and recommendations of the TEAC Committee, for Board approval.

### 2.6.1 Market Efficiency Analysis and Stakeholder Process

PJM's market efficiency analysis involves several phases. The process begins with the determination of the congestion drivers that may signal market inefficiencies. PJM will collect and publicly post relevant drivers. These metrics will be reviewed by PJM and all stakeholders to assess the system areas that are most likely candidates for market efficiency upgrades. In addition, PJM will perform market simulations to determine projections of future market congestion based on the anticipated RTEP upgraded system. This process facilitates concurrent PJM and stakeholder review of the same information considered by PJM in preparation for PJM's solicitation of stakeholder input for upgrades that may economically alleviate market inefficiencies. This solicitation of input will be to the appropriate TEAC or Subregional RTEP Committee. Following the evaluation of congestion drivers and solicitation of remedies, PJM will initiate an analysis phase which first examines the potential economic costs and benefits that may be associated with any upgrades specified during the reliability analysis. After this assessment, PJM will evaluate the economic costs and benefits of any identified new potential upgrades target specifically at economic efficiency. The following information looks at each of these phases in more detail.

### 2.6.2 Determination and evaluation of historical congestion drivers

All PJM metrics of historical congestion drivers will be posted monthly throughout the year, except that AAR information will be posted as specified by the AAR auction process. This information can be found at:

<http://www.pjm.com/planning/rtep-development/market-efficiency.aspx>

<http://www.pjm.com/markets-and-operations/ptr.aspx>

PJM will calculate and post gross congestion costs by constraint for each constraint causing real-time off-cost operations. Gross congestion will be calculated as the product of the constraint shadow price times the load MWs at each load bus in the affected area times the load bus dfax where the affected area is defined as any bus with a dfax of 3% or greater.

PJM will calculate and post the Unhedgeable congestion cost statistics and associated constraints. Unhedgeable congestion costs will be calculated by taking the sum of load MWs at each load bus in the affected area times the relevant load bus dfax minus the sum of economic generation MWs at each generator bus in the affected area times the relevant generator bus dfax minus the sum of FTR MWs, and multiplying the resulting MW by the constraint shadow price. Economic generation is generation which is available and on-line and which, at its current level of output, has a bid price no greater than the PJM system marginal price. Self-scheduled generation is assigned a bid price of zero in the determination of economic generation MW.

Congestion causing a pro-ration of Stage 1A ARR requests will be determined and recommended for inclusion in the RTEP with a recommended in-service date based on the 10-year Stage 1A simultaneous feasibility analysis results. This recommendation will also include a high-level analysis of the cost and economic benefits of the upgrade as additional information but such upgrades will not be subject to market efficiency cost/benefit analysis. More information on the ARR allocation auction process can be found in Manual 6 titled PJM Capacity Market.

Congestion causing pro-ration of Stage 1B ARR requests will be addressed using the “with and without” analysis and the benefit/cost ratio threshold described previously in this market efficiency material.

### 2.6.3 Determination of projected congestion drivers and potential remedies

PJM will provide all stakeholders with estimates of the projected congestion by performing annual hourly market simulations of future years using a commercially available market analysis software modeling tool (see assumptions and criteria material in Section 1.) This simulation will produce and PJM will post projected binding constraints, binding hours, average economic impact of binding constraints, and cumulative economic impact of binding constraints for the four RTEP market efficiency analyses (current year plus 1, current year plus 4, current year plus 7 and current year plus 12).

This analysis is expected to be completed about the **third quarter** of the RTEP cycle year. At this time PJM will also facilitate a TEAC or Subregional RTEP Committee meeting, as appropriate, to review congestion and solicit feedback from the stakeholders’ review of the projected congestion data as well as the historical congestion data. All stakeholders can provide input to PJM’s consideration of the congestion data and potential upgrades to be considered for market efficiency solutions to identified economic issues.

The timing of this meeting will depend, to some extent, on the complexity of the analysis, however, it is anticipated that this meeting will occur during the **third quarter** of each year. At this meeting, PJM will provide a summary of the analysis results and a description of any congested areas that will be analyzed using Market Efficiency analysis. PJM will also provide a high-level estimate of the transmission upgrades then being considered. At the completion of this stakeholder review, any member of the TEAC can provide additional written comments within sixty (60) days of this meeting.

#### Stakeholder Written Comments

These written comments will consist of three (3) sections:

- Introduction, which will describe the party submitting the comments and their reason for submitting these comments
- Summary, which will consist of no more than 3 pages summarizing the positions described in the written comments
- Discussion, which will consist of no more than 20 pages describing in detail the positions taken by the party

Parties wishing formally to submit alternative proposals of their own are encouraged to do so separately, as described further, below.

The Office of the Interconnection will have the responsibility of compiling comments from TEAC participants. All written comments will be posted to the PJM web site and provided to the PJM Board of Managers together with a PJM staff summary that will focus on conveying the following: (1) the issues; (2) the parties raising the issues; and, (3) as may be appropriate, PJM's discussion of ramifications of the issues. Communication to the Board of Managers will not include results of any voting.

### **2.6.4 Evaluation of cost / benefit of advancing reliability projects**

PJM will perform annual market simulations and produce cost / benefit analysis of advancing reliability projects. An initial set of simulations will be conducted for each of the four years (current year plus 1, current year plus 4, current year plus 7 and current year plus 10) using the "as is" transmission network topology without modeling future RTEP upgrades. A second set of simulations will be conducted for each of the four years using the as planned RTEP upgrades. A comparison of the "as is" and "as planned" simulations will identify constraints which have caused significant historical or simulated congestion costs but for which an as-planned upgrade will eliminate or relieve the congestion costs to the point that the constraint is no longer an economic concern. A comparison of these simulations will also reveal if a particular RTEP upgrade is a candidate for acceleration or expansion. For example, if a constraint causes significant congestion in year 7 but not in year 10 then the upgrade which eliminates this congestion in the year 10 simulation may be a candidate for acceleration. The benefit of accelerating this upgrade would then be compared to the cost of acceleration as described below before recommendation for acceleration is made.

When the reliability project economic acceleration analyses have been completed, PJM will schedule a TEAC or Subregional Committee meeting, as appropriate, to review the results. The timing of this meeting will depend, to some extent, on the amount and complexity of analysis that must be performed. However, it is anticipated that this meeting will take place during the **fourth quarter** of each year. At this meeting PJM will provide a summary of the

analysis results, including an update of the Market Efficiency analysis and a description of any recommendations for accelerating reliability projects based on economic considerations.

### **2.6.5 Determination and evaluation of cost / benefit of potential RTEP projects specifically targeted for economic efficiency**

PJM will perform annual market simulations and produce cost / benefit analysis of projects specifically targeted for economic efficiency. The net present value of annual benefits will be calculated for the first 15 years of upgrade life and compared to the net present value of the upgrade revenue requirement for the same 15 year period.

An initial set of simulations will be conducted for each of four years (current year plus 1, current year plus 4, current year plus 7 and current year plus 10) using the as planned transmission network topology as defined by the most recent RTEP. A second set of simulations will be conducted for each of the four years using the as planned transmission network topology plus the upgrade being studied. The upgrade will be included in each of the four simulation years regardless of the actual anticipated in-service date of the upgrade. A comparison of these simulations will identify the benefit of the upgrade in each of the four years analyzed. Annual benefits within the 10-year time frame for years which were not simulated would be interpolated using these simulation results. A forecast of annual benefits for years beyond the 10-year simulation time frame would be based on an extrapolation of the market simulation results from the studied years. A higher-level annual market simulation will be made for future year 15 to validate the extrapolation results and the extrapolation of annual benefits for years beyond the 10-year simulation time frame may be adjusted accordingly. This high level simulation of future year 15 may require a less detailed model of the transmission system below the 500 kV level.

An extrapolation of the simulation results will provide a forecast of annual upgrade benefits for each of the anticipated first 15 years of upgrade life, beginning from the projects anticipated in-service date. The present value of annual benefits projected for the first 15 years of upgrade life will be compared to the present value of the upgrade revenue requirement for the same 15 year period to determine if the upgrade is cost beneficial and recommended for inclusion in the PJM RTEP. If the ratio of the present value of benefits to the present value of costs exceeds 1.25 then the upgrade is recommended for inclusion in the RTEP.

For each upgrade which is recommended for inclusion in the RTEP, PJM will provide the level of new generation or DSM per region that would eliminate the need for the transmission upgrade.

When the economic efficiency project evaluations have been completed, PJM will schedule a TEAC or Subregional Committee meeting, as appropriate, to review the results. The timing of this meeting may depend on the amount and complexity of analysis that must be performed. It is, however, anticipated that this meeting will take place **by April** of the calendar year that begins the subsequent RTEP planning cycle. At this meeting PJM will provide a summary of the analysis results, including an update of the Market Efficiency analysis, and a description of any recommendations for economic efficiency projects.

### **2.6.6 Determination of final RTEP market efficiency upgrades**

PJM will perform a combined review of the accelerated reliability projects and new market efficiency projects that passed the economic screening tests to determine if there are

potential upgrades with electrical similarities. This may result in new projects to replace the original projects to form a more efficient overall market solution. Stakeholders may also suggest such potential synergies. PJM will evaluate the cost / benefits of any such resulting “hybrid” projects<sup>3</sup>. The final list of reliability projects and market efficiency projects, including any “hybrid” projects will be presented and discussed at a **second quarter (April)** TEAC meeting. At this TEAC meeting PJM will review all the Market efficiency plans resulting from this cycle of market efficiency studies. Recommended projects will be taken to the PJM Board for endorsement, and will either be included in subsequent RTEP analysis if there is a “volunteer” to build the project, or a report will be filed with FERC in accordance with Schedule 6 of the PJM Operating Agreement. As part of this request for endorsement, PJM will provide the written comments submitted by the parties, and will discuss these written comments with the PJM Board.

Within the limits of confidential, market sensitive, trade secret, and proprietary information, PJM will make all of the information used to develop the Market Efficiency recommendations available to market participants to use in their own, independent analyses.

For each enhancement which is analyzed, PJM will calculate and post on its website changes in the following metrics on a zonal and system-wide basis: (i) total energy production costs (fuel costs, variable O&M costs and emissions costs); (ii) total load energy payments (zonal load MW times zonal load Locational Marginal Price); (iii) total generator revenue from energy production (generator MW times generator Locational Marginal Price); (iv) Financial Transmission Right credits (as measured using currently allocated Auction Revenue Rights plus additional Auction Revenue Rights made available by the proposed acceleration or modification of a planned reliability-based enhancement or expansion or new economic-based enhancement or expansion); (v) marginal loss surplus credit; and (vi) total capacity costs and load capacity payments under the Reliability Pricing Model construct.

For each market efficiency project proposed for RTEP, PJM will also post, as soon as practical, the following:

- a. Anticipated high-level project schedule and milestone dates
- b. Final commitment date after which any change to input factors or drivers will not result in transmission project deferral or cancellation.

After this TEAC meeting, any member of the TEAC can provide written comments within sixty (60) days of this meeting. These written comments will consist of three (3) sections:

- Introduction, which will describe the party submitting the comments and their reason for submitting these comments
- Summary, which will consist of no more than 3 pages summarizing the positions described in the written comments
- Discussion, which will consist of no more than 20 pages describing in detail the positions taken by the party

---

<sup>3</sup> Hybrid transmission upgrades include proposed solutions which encompass modification to reliability-based enhancements already included in RTEP that when modified would relieve one or more economic constraints. Such hybrid upgrades resolve reliability issues but are intentionally designed in a more robust manner to provide economic benefits in addition to resolving those reliability issues.

### 2.6.7 Submitting Alternative Proposals

Any TEAC member or other entity (consistent with PJM Operating Agreement Schedule 6 provisions), may formally submit alternative proposals for evaluation under the Market Efficiency analysis at any time, but no later than **December 31<sup>st</sup>** of each year RTEP cycle year in order to be considered in the then-current planning cycle (the RTEP market efficiency planning analysis carries over from the RTEP cycle year into the first quarter of the following RTEP planning cycle year.) These alternatives will be posted on the PJM Website. PJM will consider these alternatives, and establish the final set of proposals to be included in market efficiency analysis. The process of formally submitting proposals is not limited to transmission solutions but may also include generation solutions via PJM's established interconnection queue process; or, demand side management and load management proposals as well. Alternatively, market projects to relieve congestion can be submitted by market participants through the queue process at any time. PJM will evaluate these projects under the then current business rules contained in the PJM Tariff and Operating Agreement.

Regardless of all proposals considered – whether proposed by PJM or other parties - PJM will establish a “go/no-go” decision-point deadline (or final commitment date) after which existing RTEP transmission components will not be deferred or cancelled. This will provide certainty to developers, owners and investors.

### 2.6.8 Ongoing Review of Project Costs

To assure that projects selected by the PJM Board for Market Efficiency continue to be economically beneficial, both the costs and benefits of these projects will periodically be reviewed, nominally on an annual basis. Substantive changes in the costs and/or benefits of these projects will be reviewed with the TEAC at a subsequent meeting to determine if these projects continue to provide measurable economic benefit and should remain in the RTEP.

For projects with a total cost exceeding \$50 million, an independent review of project costs and benefits will be performed to assure both consistency of estimating practices across PJM and that the scope of the project is consistent with the project as proposed in the Market Efficiency analysis.

## 2.7 Evaluation of Operational Performance Issues

As per Schedule 6, section 1.5 of the PJM Operating Agreement, PJM is required to address operational performance issues and include system enhancements, as may be appropriate, to adequately address identified problems. To fulfill this obligation, PJM Transmission Planning staff and Operations Planning staff annually review actual operating results to assess the need for transmission upgrades that would address identified issues. Typical operating areas of interest in these reviews include Transmission Loading Relief (TLR) and Post Contingency Local Load Relief Warning (PCLLRW) events.

The first operational performance issue to be addressed through the RTEP was an upgrade of the Wylie Ridge 500/345 kV transformation. The metric applied to designate Wylie Ridge an operational performance issue was the TLR metric. This same metric is applied consistently across the PJM footprint.

In addition, PJM has also developed and initiated use of a tool for Probabilistic Risk Assessment (PRA) of transmission infrastructure. PJM's 500/230 kV transformer

infrastructure has been identified as particularly suited for assessment using this tool. PRA is further discussed in following sections.

### **2.7.1 Operational Performance Metrics**

Events and metrics considered in the annual operational performance reviews are not limited to a specifically defined list and will be responsive to events and conditions that may arise. In addition, PJM stakeholders may raise operational issues to PJM's attention for consideration during the RTEP process through interactions with the Planning, TEAC or Subregional RTEP Committees.

The PJM TLR metric identifies facilities that result in over 1,000 hours or 100 occurrences of TLR level 3 or higher on an annual basis. These facilities will be evaluated through the RTEP process for system enhancement.

For PCLLRW events, PJM will review all such events after the conclusion of the peak season. The initiating facilities will be determined and the expected impacts of planned RTEP upgrades will be reviewed and the need for additional planned upgrades will be evaluated.

PRA evaluation uses an economic analysis of the cost of the investment that mitigates a risk and the dollar value of the avoided risk. The mitigation strategy cost, prime rate and payback period are used to determine if the strategy cost is less than the value of risk. Projects with lower cost than risk are candidates for the RTEP.

### **2.7.2 Probabilistic Risk Assessment of PJM 500/230 kV Transformers**

One significant element of PJM's operational performance reviews involves a risk evaluation aimed at anticipating significant transmission loss events. PJM integrates aging infrastructure decisions into the ongoing RTEP process: analysis, plan development, stakeholder review, PJM Board approval, and implementation, over PJM's entire footprint. Thus, the aging infrastructure initiative implements a proactive, PJM-wide approach to assess the risk of transmission facility loss and to mitigate operational and market impacts of such losses.

PRA's initial implementation at PJM is a risk management tool employed to reduce the potential economic and reliability consequences of transmission system equipment losses. In collaboration with academia, vendors and member TOs, PJM integrated various input drivers into a transformer PRA initiative to manage 500/230 kV transformer risk. In the case of the 500/230 kV transformers, risk is the product of the probability of incurring a loss and the economic consequence of the loss. Probability of loss is determined based on the individual transformer unit's condition assessments and vintage history. Economic loss impact is based upon the duration of the loss and the accumulation of unhedgeable congestion costs, or the increased cost of running out of merit generation to meet load requirements after a transformer loss. If lead times for 500/.230 kV transformer units are as great as eighteen months, then outage durations can be long if adequate loss mitigation is not in place. The PRA outputs the annual risk to the PJM system of each transformer unit in terms of dollars. The annual risk dollars are then used to justify mitigating solutions such as redundant bank deployment, proactive replacement or adding spares. The deployment strategy chosen will depend on the level of risk mitigation and reliability benefit.



While initially developed for aging 500/230 kV transformers, the PRA tool is capable of assessing other equipment types and other transformer voltage classes. The PRA tool is commercially available software.

## Attachment A: PJM Baseline Cost Allocation Procedures

### A.1 Purpose

One of the responsibilities of PJM as an RTO is to allocate the cost responsibility for all system reinforcement projects including projects required for Customer interconnection requests, baseline transmission reliability upgrades and market efficiency upgrades. The cost allocation procedures used by PJM for baseline upgrades are described below. Manual 14A addresses request-driven upgrade cost allocation procedures.

### A.2 Scope

The PJM Cost Allocation Procedures are presented in two parts: “PJM Generation and Transmission Interconnection Cost Allocation Methodologies” discusses the cost allocation methodology for projects required for generator and transmission interconnections in Manual 14A and: “Schedule 12 Cost Allocation Process for Baseline Transmission Reliability and Market Efficiency Upgrades” describes the cost allocation process for baseline transmission reliability and market efficiency upgrade project requirements.

### A.3 Schedule 12 Cost Allocation Process for Baseline Transmission Reliability and Market Efficiency Upgrades

In addition to allocating the costs of interconnection projects (described above), PJM is responsible, under Schedule 6 of the Operating Agreement and Schedule 12 of the Tariff, for determining the cost allocation of all RTEP upgrades and submitting them to the PJM Board for approval. Allocation of transmission upgrades for reliability is cost-causation based. With respect to reliability, the determination of benefit is based on the elimination of a reliability criteria violation. The parties causing the violation are the parties that benefit through the elimination of the violation and the quantification of the benefit is based on the relative contribution to the violation being eliminated. Accordingly, each cost allocation calculation is based on the particular assumptions used to determine whether or not a violation exists of a particular criterion.

#### A.3.1 RTEP Baseline Cost Allocation

PJM’s allocation of cost responsibility for RTEP reliability baseline upgrades in accordance with these provisions is based on cost causation. The market participants (typically load) that create the circumstances that would constitute a violation of reliability criteria are those that will benefit from elimination of that violation. Therefore, the quantification of the relative benefits of eliminating the violation, and thus the quantification of relative responsibility for the cost of the system upgrade(s) needed to remove the violation, is based on the relevant market participants’ relative contribution to the violation to be eliminated.

The planning (modeling) assumptions associated with each reliability criterion in PJM are highly prescriptive, such that discretion cannot be applied to manipulate the determination that a violation does or does not exist. The reliability criteria and the associated modeling rules were established in this way specifically to ensure consistency of application and ability to replicate results. In this way, once it is determined that an applicable criterion has been violated, it is a simple matter to determine the extent to which load within each

transmission zone contributes to that violation. That relative contribution then establishes the appropriate, proportional allocation to each zone of the costs required to remove the violation.

To the extent that a criteria violation is based on the thermal limits of a transmission facility, the cost allocation is based directly on the relative contribution of the load in each zone to the flow on that facility. For criteria violations based on voltage criteria, thermal surrogates are determined, such that the flow on a transmission facility or group of facilities best correlates to the reactive performance of the system at the point of the criteria violation. The same approach described above is then utilized to simulate incremental flows on the limiting facilities, i.e., the thermal surrogate that best correlates to the violation. Accordingly, the cost allocation for the solution to the voltage criteria violation is, again, based on the relative contribution of load in each zone to flow on the limiting facility, in these cases, the thermal surrogates.

Under this approach to cost allocation, it is entirely possible, and certainly consistent with the philosophy of assessing relative cost-causation, that the costs of upgrades that are required to mitigate criteria violations in one transmission zone may be allocated in significant part to load in other transmission zones. While many required transmission upgrades are allocated entirely to load within the same zone where the criteria violation and the related upgrade are located, the nature of large, integrated transmission systems like the PJM system is such that the needs of one area can cause or contribute to problems in other areas. The planning process identifies the most effective solutions to criteria violations without regard to the location of the load that causes such violations. Therefore, responsibility for the costs of baseline upgrades likewise must be allocated to those who cause such costs to be incurred, regardless of their physical location relative to the location of the baseline upgrade required to ensure the reliability of their service.

The basic steps for calculating the cost allocations for baseline upgrades can be summarized as follows:

#### Generator Deliverability and NERC Category C Load Flow Violations

Calculate the Distribution Factor (DFAX), where DFAX represents a measure of the effect of each zone's load on the transmission constraint that requires the mitigating upgrade, as determined by power flow analysis. The source used for the DFAX calculation is the aggregate of all PJM generation and the sink is each Transmission Owners peak zonal load.

Multiply each DFAX by each zonal load to determine the zone's MW impact on the facility that requires upgrading.

Divide MW impact for each zone by sum of all MW impacts to yield baseline cost allocation factors.

#### Load Deliverability Violations

Calculate the Distribution Factor (DFAX), where DFAX represents a measure of the effect of each zone's load on the transmission constraint that requires the mitigating upgrade, as determined by power flow analysis. The source used for the DFAX calculation is the aggregate of all generation external to the study area and the sink is the peak zonal load for each Transmission Owner within the study area.

Multiply each DFAX by each zonal load to determine the zone's MW impact on the facility that requires upgrading.



Divide MW impact for each zone by sum of all MW impacts to yield baseline cost allocation factors.

Market Efficiency Allocation

[As of the effective date of this Revision 12 of Manual 14B, the cost allocation method for transmission upgrades is currently being debated at the FERC and is yet to be determined. Neither the RPPWG nor Planning Committee are recommending or endorsing any cost allocation method, pending the outcome of the proceedings at the FERC.]

The dollar benefit in all zones with affected load is summed and the final allocation is the zonal dollar benefit divided by the total dollar benefit.

**RTEP Baseline Cost Allocation Representative Example**

In order to explain the derivation of baseline cost allocation factors, PJM offers the following representative example based on Upgrade # b0174, an upgrade to the Portland – Greystone 230 kV circuit.

Cost Allocation Procedure	AE	JCPL	Neptune	PSE&G	RECo
1. Calculation of Distribution Factors (DFAX), representing a measure of the impact of each zone's load on the constraint requiring the mitigating upgrade in the first place, as determined by power flow analysis.	0.27%	2.42%	3.57%	2.76%	3.02%
2. Transmission Owner Load (MW)	2995	6713	685	10760	445
3. Calculate MW Impact (MW) of each TO zone by multiplying DFAX by TO Load.	8.09	162.45	24.45	296.98	13.44
4. Total MW Impacts (MW) across zones	505.41				
5. Calculate cost allocation factors by dividing each zone's MW Impact by the Total MW Impact across all zones. (Values rounded)	1.00%	32.00%	5.00%	59.00%	3.00%

## Attachment B: Regional Transmission Expansion Plan—Scope and Procedure

### B.1 Purpose

The purpose of the Regional Transmission Expansion Plan (RTEP) is to develop plans which will assure reliability and meet the demands for firm transmission service in the PJM Region as described in Schedule 6 of the Operating Agreement.

### B.2 Scope

As part of its ongoing responsibility, PJM Interconnection, LLC (PJM) will prepare a Regional Transmission Expansion Plan (RTEP) which shall consolidate the transmission needs of the region into a single plan. The RTEP shall reflect transmission enhancements and expansions, load and capacity forecasts, and generation additions and retirements for the ensuing five years. The RTEP shall also reflect new transmission construction and right-of-way acquisition required to support load growth in years 6 through 15.

The RTEP will:

- A. Provide a 5-year plan (“near term plan”) to address needs for which a commitment to expand or enhance the transmission system must be made in the near term in order to meet scheduled in service dates.
- B. PJM will develop the necessary documentation of previous year’s RTEP analyses and updates to demonstrate compliance with applicable criteria. Such documentation may include the most recent Baseline study for each year in the near-term planning horizon (current year through current year plus 5,) annual changes to each year’s baseline study assumptions for generation, transmission and load compared to the current year’s assumptions for each respective study year, and retool studies to evaluate and ensure compliance with applicable standards and criteria for significant changes proposed to the system (Interconnection and New Service Requests.) The need for additional baseline retools will be considered and any needed restudy will be performed and reported.
- C. Provide a 15-year plan (“long term plan”) to address new transmission construction and right-of-way acquisition. System evaluations will be performed to:
  - Identify overloads 230 kV and above due to load growth for years 6 through 15. This will be completed using DC analysis only.
  - Include in the RTEP any new 230 kV or 345 kV circuits identified as required to support load growth in years 6 through 8.
  - Include in the RTEP any right-of-way acquisition required for any new 230 kV or 345 kV circuits identified as required to support load growth in years 9 and 10.
  - Include in the RTEP any new circuits 500 kV or greater identified as required to support load growth in years 6 through 12.

- Include in the RTEP any right-of-way acquisition required for any new circuits 500 kV or greater identified as required to support load growth in years 13 through 15.
- D. Include reactive planning to determine if any new transmission identified in the 15-year plan should be accelerated to mitigate identified voltage criteria violations. Additional details for the reactive planning follow:
- Development of a 10-year RTEP base case that will include Transmission Owner reactive plans.
  - The long term plan voltage analysis will be performed using contingencies 345 kV and greater and monitoring substation voltages 345 kV and greater. Analysis of lower voltage systems will be completed on an exception basis only.
  - Voltage analysis will be performed for areas where PJM identified thermal problems in years 6 through 15 or other areas as identified by PJM.
  - Based on the results of the voltage analysis, PJM will recommend appropriate modifications to the RTEP through the Transmission Expansion Advisory Committee.
- E. Provide an assessment based on maintaining the PJM region’s reliability in an economic manner.
- F. Avoid any unnecessary duplication of facilities.
- G. Avoid the imposition of unreasonable costs on any Interconnected Transmission Owner (ITO) or any user of transmission facilities.
- H. Take into account the legal and contractual rights and obligations of the Interconnected Transmission Owners.
- I. Provide, if appropriate, alternative means for meeting transmission needs in the PJM Region.
- J. Provide for coordination with existing transmission systems and with appropriate interregional and local expansion plans.
- K. Include a designation of the Interconnected Transmission Owner or Owners or other entity that will own a transmission facility and how all reasonably incurred costs are to be recovered.
- L. Identify local system limitations discovered in analyzing the Transmission System.
- M. Include Scenario Planning evaluations beginning in mid-2006. Scenario Planning examines the long-term impacts on the reliability of the PJM system from uncertainty with respect to certain assumptions implicit in the development of the RTEP. PJM will examine the effects of uncertainty with respect to selected variables such as economic growth effect on the Load Forecast, Circulating transmission flow effects on system deliverability and generation scaling sensitivities.
- N. Include Probabilistic Risk Assessment (PRA) of Aging Transmission System Infrastructure beginning in 4Q, 2006. PRA is employed to mitigate transformer risk on the bulk power system. The consequences of a failure, both reliability and economic impacts, are then considered to implement, when appropriate, a

proactive, PJM-wide approach to mitigate operational and market impacts to such failures.

The RTEP will not:

- A. Include an evaluation of Transmission Owner transmission expansion or enhancement plans for local area load supply, which are not needed for reliability, market efficiency or operational effectiveness of the Transmission System and do not otherwise negatively impact the Transmission System. These Transmission Owner projects (Supplemental Projects) will be identified in the RTEP for information purposes and tracked for possible future impact implications.
- B. Include any upgrades based solely on scaling up of generation to solve load flow studies for years 6 through 15.

### **B.3 Procedure**

- I. Solicit input and coordinate with Transmission Expansion Advisory Committee (TEAC) and, as appropriate, TEAC's Subregional RTEP Committee.
  - A. Present the preliminary results of the most recent, applicable NERC regional reliability council (ReliabilityFirst and SERC) Reliability Assessments and the most recent PJM Regional Transmission Expansion Plan (RTEP).
  - B. Present a summary of the transmission expansion or enhancement needs that will be addressed in the RTEP.
  - C. Provide periodic updates to the TEAC on status of the RTEP.
  - D. Solicit input on future transmission needs and requirements from those who will not be contacted directly as listed below.
  - E. Schedule and facilitate Subregional RTEP committee reviews as may be needed to foster the goal of a transparent and participatory planning process.
- II. Identify known Transmission System expansion or enhancement needs from the following plans and analysis results:
  - A. Most recent, applicable Reliability Assessments (ReliabilityFirst and SERC) – (on PJM website)
  - B. Most recent PJM Annual Report on Operations – (on PJM website)
  - C. PJM Load Serving Entity (LSE) capacity plans
  - D. Generator and Transmission Interconnection requests
  - E. Transmission Owner transmission plans
  - F. Interregional transmission plans.
  - G. Firm Transmission Service Requests
  - H. PJM Transmission Expansion Advisory Committee (TEAC) and Subregional RTEP Committee input
  - I. PJM Development of Economic Transmission Enhancements

- III. PJM will consider the RTEP impacts of each Generation Interconnection Customer (“GIC”) and/or Transmission Interconnection Customer that is currently engaged in discussion with PJM concerning plans for siting generating and/or transmission facilities.

Typical items to be included are as follows:

- A. GIC and/or Merchant Transmission Facilities developer project status, schedule, and milestones.
  - B. PJM will review the status of studies currently being performed or scheduled to be performed by PJM for the GIC and/or Merchant Transmission Facilities developer.
- IV. GIC and/or Merchant Transmission Facilities developer plans will be included in the RTEP based on the following criteria:
- A. Developer must be presently engaged in discussion with PJM concerning their plans for siting generating and/or transmission facilities and actively pursuing those plans. Interconnection Studies in response to requests for Generator and/or Transmission Interconnections will be conducted in accordance with the following scope:
    - Identify transmission enhancements required to meet reliability requirements over the next 5 years.
    - No studies will be conducted beyond 5 years for interconnection projects.
    - “But-for” costs will be applicable toward all system upgrades identified in the RTEP Baseline.
  - B. GIC and/or Merchant Transmission Facilities developer plans will be treated equal to LSE plans submitted via EIA 411 in that they will be explicitly modeled and explicitly included in the RTEP report.
  - C. GIC and/or Merchant Transmission Facilities developer plans, which have not been released publicly, will be masked to the greatest extent possible to preserve the confidentiality of the developer’s identity and specific site location(s).
  - D. GIC and/or Merchant Transmission Facilities developer plans, which were developed as a result of a PJM feasibility study or are being developed in conjunction with a PJM feasibility study being performed concurrent with the RTEP process, will be evaluated explicitly during the RTEP.
  - E. GIC and/or Merchant Transmission Facilities developer plans which have not undergone a PJM feasibility study or are not actively being developed as a result of an agreement executed with PJM to perform a feasibility study concurrent with the RTEP process, will only be considered to the extent that the GIC generator installation or Merchant Transmission Facilities developer facility may affect the sensitivity of transmission enhancement or expansion alternatives which are being evaluated.
- V. PJM will exchange information and data with each Transmission Owner (TO) for the purpose of developing RTEP assumptions in preparation for the Subregional RTEP Committee assumptions meeting. Typical items to be included are as follows:
- A. TOs will verify their transmission and capacity plans.

- B. TOs and PJM will discuss the status, impact, and schedule of relevant studies in which they are mutually engaged in performing.
  - C. TOs will provide information concerning the contractual rights and obligations which PJM must consider per the RTEP protocol as listed in Schedule 6 of the PJM Operating Agreement.
  - D. TOs will provide PJM with any information related to concerns, operating procedures, or special conditions for each of the TO's systems that PJM should consider related to the analysis to be performed for the RTEP.
  - E. TOs will discuss the accuracy of PJM's load flow representation for each of the TO's systems including the impact of using the present representation for each of the TO's underlying systems.
  - F. TOs will identify system needs which are currently not identified by published transmission plans but could be included for consideration during the RTEP analysis.
  - G. TOs will provide the names, addresses, telephone numbers, FAX number, and email address for personnel identified to interact with PJM on matters dealing with the RTEP process.
  - H. TOs will provide a confidentiality statement regarding all information released to the TO by PJM during the course of the RTEP process.
  - I. TOs will provide information on new loads or changing loads that will impact the transmission plan.
- VI. PJM will include available information from neighboring TOs / Regional Transmission Operators, gained in the course of interregional planning activities, related to plans in other regions which may impact the PJM RTEP.
- VII. RTEP Analysis General Assumptions:
- A. PJM System Models will be drawn from the PJM and applicable regional reliability council (ReliabilityFirst and SERC) central planning database which includes transmission plans consistent with the most recent FERC 715 Report and most recent Regional EIA-411 Reports.
  - B. LSE capacity models are to be based on the most recent Regional EIA-411 Reports.
  - C. GIC capacity plans will be modeled as described in Procedures III and IV.
  - D. When the PJM load in the RTEP model exceeds the sum of the available in-service generation plus generation with an executed ISA, PJM will model new generation to accommodate additional load growth by including queued generation that has received an Impact Study.
  - E. PJM Load Forecasts are to be based on the most recent LAS Report.
  - F. Power Flow models for world load, capacity, and topology will be based on the most recent Eastern Reliability Assessment Group (ERAG) power flow base cases.
  - G. Generation outage rates will be based on the most recent generator unavailability data available to PJM. Estimates, based on historical outage rates for similar in-

- service units, will be used for all generating units in the neighboring regions and for all future PJM units.
- H. Firm sales to, and firm purchases from, regions external to PJM will be modeled consistent with the ERAG base interchange schedule.
  - I. Only PJM's share of generation will be modeled to serve PJM load. Generation located within PJM, but not committed to PJM, will be accounted for in the interchange schedule.
  - J. The Reliability Principles and Standards as shown on Attachment D to this Manual 14B, "PJM Reliability Planning Criteria."
  - K. Stability analysis and short circuit studies will also be performed.
  - L. All PJM Transmission System facilities 100 kV and greater, and all tie lines to neighboring systems will be monitored.
  - M. Contingency analysis will include all facilities operated by PJM.
  - N. The published line and transformer thermal ratings at ambient temperatures of 50°F (10°C) winter and 95°F (35°C) summer will be used for all facilities.
  - O. The voltage limits applied for planning purposes will be the same as applied in PJM Operations.
  - P. PS/ConEd PAR Flows: Model a 1000MW import at Waldwick and 1000MW Export at Goethals and Farragut with Ramapo PARS controlling 920 MW to NYPP. Except, for load deliverability testing, the export to ConEd at Goethals and Farragut may be decreased to 600 MW to represent a 400 MW emergency PJM purchase from NY for the capacity deficiency conditions being modeled. Likewise, the Ramapo setting is changed to 1000 MW into New Jersey.
  - Q. Assumptions used for the economic analysis and comparison of alternatives will be included in the report.
  - R. Planning and Markets will, annually based on historical data, develop a circulation model to be applied to the 5 year RTEP base case. This assumption will be reviewed with the PJM Planning Committee prior to implementation.
- VIII. Evaluate Transmission enhancement and expansion alternatives and develop a coordinated Regional Transmission Expansion Plan.
- A. Develop solution alternatives for regional and subregional transmission needs.
  - B. Evaluate solutions on a regional basis and optimize solutions to address needs on a coordinated regional basis in a single plan.
  - C. Test the single regional plan for reliability, economy, flexibility, and operational performance based on forecasts for future years.
- IX. RTEP Deliverables
- A. A 5-year plan, which includes recommended regional transmission enhancements, including alternatives if applicable, that address the transmission needs for which commitments need to be made in the near term in order to meet scheduled in-service dates.

- B. The 5-year plan will include planning level cost estimates and construction schedules.
- C. The 5-year plan will specify the level of budget commitments which must be made in order to meet scheduled in-service dates. The commitment may include facility engineering and design, siting and permitting of facilities, or arrangements to construct transmission enhancements or expansions.
- D. The 15-year plan will identify new transmission construction and right-of-way acquisition requirements to support load growth.

## B.4 Scenario Planning Procedure

Beginning in mid-2006, PJM will include scenario planning evaluations as part of the RTEP process. Scenario planning examines the long-term impacts on the reliability of the PJM system due to uncertainty with respect to certain assumptions implicit in the development of the RTEP. PJM will examine the effects of uncertainty with respect to selected variables such as economic growth effect on the load forecast, circulating transmission flow effects on system deliverability and generation sensitivities. In the course of the RTEP planning cycle scenario planning will evaluate Transmission System requirements, as may be necessary to ensure the robustness of the RTEP. The following sensitivities will be considered:

### I. Load forecast for economic growth

The current 90/10 load values only account for weather uncertainty and do not consider economic growth deviations. An economic growth sensitivity may consider the effects of high economic growth factors and higher than forecast loads to determine the impact on RTEP baseline upgrades identified for years 6 through 10 for:

- Eastern PJM Mid-Atlantic Region (PSE&G, JCP&L, PECO, Delmarva, AE and RECO).
- Southwestern PJM Mid-Atlantic Region (PEPCO and BG&E).
- Western PJM Mid-Atlantic Region (MetEd, PPL, UGI and Penelec).
- PJM Western Region (ComEd, AEP, Dayton, Duquesne and AP).
- PJM Southern Region (Dominion).

System upgrades identified as required in years 6 through 10 may be advanced if the initiating overload occurs in an earlier year due to the high economic growth factor scenario.

### II. Circulation

Circulation assumptions included in the RTEP baseline analysis will be reviewed for appropriate sensitivities.

### III. Generation sensitivities

When the PJM load in the RTEP model exceeds the sum of the available in-service generation plus generation with an executed ISA, PJM will model new generation to accommodate additional load growth by including queued generation that has received an Impact Study. This newly added generation could affect the load deliverability results either by advancing or mitigating limits. Generation sensitivities may be examined as appropriate to add information regarding the impacts of any such generators with less



certain in-service dates. In addition, in areas that are experiencing load deliverability issues, sensitivities to the mitigating effects of new local generation may also be quantified.

PJM will analyze the results of any generation sensitivities for consideration of adjustments to any new transmission or ROW acquisition previously identified in the RTEP for years 6 through 15.

#### IV. Additional Information

For any overloads that resulted in transmission or ROW acquisition in years 6 through 15, PJM will provide the level of new generation or DSM per region that would eliminate the need for the transmission or ROW acquisition.

## Attachment C: PJM Deliverability Testing Methods

### C.1 Introduction

Schedule 10 of the PJM Reliability Assurance Agreement states that Capacity Resources must be deliverable, consistent with a loss of load expectation as specified by the Reliability Principles and Standards, to the total system load, including portion(s) of the system in the PJM Control Area that may have a capacity deficiency at any time. Certification of deliverability means that the physical capability of the transmission network has been tested by the Office of the Interconnection and found to provide service consistent with the assessment of transfer capability internal to PJM as set forth in the PJM Tariff and, for Capacity Resources owned or contracted for by a Load Serving Entity, that the Load Serving Entity has obtained Network Transmission Service or Firm Point-to-Point Transmission Service to have capacity delivered on a firm basis under specified terms and conditions .

PJM determines the Capacity Requirement for the entire PJM footprint to achieve this reliability objective assuming sufficient network transfer capability will exist. The energy from generating facilities that are ultimately committed to meet this capacity requirement must be deliverable to wherever they are needed within PJM in a capacity emergency. Therefore, there must be sufficient transmission network transfer capability within PJM. PJM determines sufficiency of network transfer capability through a series of Deliverability tests.

It is important to point out that deliverability ensures that the PJM Transmission System is adequate for delivery of energy from the aggregate of capacity resources to the aggregate of PJM load. Additionally, the generator deliverability test determines whether a generator qualifies for the status of a "certified" capacity resource with respect to the installed capacity obligations imposed under the Reliability Assurance Agreement. It does not guarantee any rights to specific generators to deliver energy to specific loads within PJM. Nor does it guarantee any rights to generators to produce energy during any particular set of operational circumstances. Deliverability ensures that the Transmission System within PJM can be operated within applicable Reliability Criteria and, ensures within those criteria that regional load will receive energy, with no guarantee as to price, from the aggregate of capacity resources available to PJM.

Failure of the deliverability test for a new capacity resource will result in denial of full capacity rights for the generator until such generator deliverability deficiencies are corrected. Failure of load deliverability tests will result in the initiation of appropriate mitigation actions including securing additional capacity resources, reduction of peak load and/or an enhancement to the Transmission System to increase the load area's ability to import power.

### C.2 Deliverability Methodologies

To maintain reliability in a competitive capacity market, capacity resources must contribute to the deliverability of energy within PJM in two ways. First, within an area experiencing a localized capacity emergency, or deficiency, energy must be deliverable from the aggregate of the available capacity resources to load. Second, capacity resources within a given electrical area must, in aggregate, be able to be exported to other areas of PJM. PJM has

developed testing methodologies to verify compliance with each of these deliverability requirements.

### C.3 Overview of Deliverability to Load

The first of these tests, the delivery of energy from the aggregate of available capacity resources in one PJM electrical area and adjacent non-PJM areas (support from external areas may be considered to meet deliverability to the extent such support may be reasonably expected) to another PJM electrical area experiencing a capacity deficiency, is the more common deliverability test that has been utilized within PJM for some time. It is often discussed in the context of demonstrating the "deliverability to the load" as opposed to the "deliverability of individual generation resources". This ensures that, within accepted probabilities, energy can be delivered to each PJM load area from the aggregate of capacity resources available to PJM (regardless of ownership). These tests address reliability only and do not address the economic performance of the system.

For the adequacy of generating capacity of the entire PJM footprint, the acceptable loss of load expectation (LOLE) is based on load exceeding available capacity, on average, during only one occurrence in ten years (1/10). This concept of deliverability coincides with the assumptions inherent in the determination of the PJM Installed Reserve Margin (IRM), i.e. the total amount of installed capacity necessary to be at the disposal of the PJM operator to ensure delivery of energy to load consistent with an LOLE of 1/10. The determination of the IRM is based on the assumption that the delivery of energy from the aggregate of available capacity resources to load within the PJM footprint will not be limited by transmission capability. This assumption depends on the existence of a balance between the distribution of generation throughout PJM and the strength of the Transmission System to deliver energy to portions of PJM experiencing capacity deficiencies.

The specific procedures utilized to test deliverability from the load perspective involve the calculation of Capacity Emergency Transfer Objectives (CETO) and Capacity Emergency Transfer Limits (CETL) for the various electrical areas of PJM. A CETO value represents the amount of energy that a given area must be able to import in order to remain within an LOLE of 1 event in 25 years (1/25) when that area is experiencing a localized capacity emergency. The LOLE calculation takes into account all generation within the study area including that which may not be a PJM capacity resource. The CETL represents the actual ability of the Transmission System to support deliveries of energy to an electrical area experiencing such a capacity emergency. Providing that the CETL for a given area exceeds the CETO for that area, the test is passed and, on a probabilistic level, the area will be able to import sufficient energy during emergencies. The Transmission System is tested at a LOLE of 1/25 so that the transmission risk does not appreciably diminish the overall target of a 1/10 LOLE for PJM.

To test the assumptions used in the development of the PJM Installed Reserve Margin, electrically cohesive load areas must first be defined. The historical implementation of this test based these areas on Transmission Owner service territories and larger geographical zones comprised of a number of those service territories. Current study areas include the definition of smaller areas, within service territory boundaries. These areas, known as Locational deliverability Areas (LDAs) were defined based on the impact of generators, potentially within the area and on the contingencies known to limit operations in the area. Similar techniques may be used to form future new areas to establish incentives for infrastructure that promotes reliability.

PJM will analyze the need for the addition of an LDA if either of the following criteria is met:

- RTEP Market Efficiency Analysis

Constrained facilities will be identified utilizing the market efficiency analysis. Facility constraints that are not resolved by an existing approved RTEP upgrade are identified for further consideration. PJM may propose a new LDA when annual market efficiency analysis identifies persistent congestion on a 500 kV or above facility or interface for multiple years beyond the next BRA.

- RTEP Long Term Planning

Future constrained facilities or clusters of facilities are identified utilizing the long term planning analysis. Potential facilities are screened using thresholds that are utilized in the RTEP long-term planning studies. This analysis is updated annually based on approved RTEP upgrades. 500 kV and above facilities that advance more than three years between RTEP cycles are identified for further consideration. If the driver for a 500 kV facility advancing more than three years is linked to a specific event (e.g. significant generation retirement), it may require further analysis.

Once a facility has been identified utilizing the above methods, distribution factor analysis is utilized to determine the specific busses included in the analyzed LDA. The model used to determine the load bus distribution factors would include all approved RTEP upgrades. A distribution factor cutoff is established based on one of the existing LDA's, and is dependent upon an analysis of the specific system topology and the identified constrained facility(ies).

These procedures are consistent with the changing nature of load responsibility under wholesale and retail access and provide a wider range of information about the performance of the Transmission System as electrical areas of different sizes are evaluated. The sequence of evaluating areas of differing size involves nesting small sub-areas into larger areas and finally areas into larger geographical areas of PJM to help identify the interrelationships between local and large geographical area deliverability problems.

After an area is defined, two generation patterns must be established. The first represents the capacity resource deficiency within the area. Based on the calculated CETO for the area, sufficient resources must be removed from service to create a need to import energy into the area. As the magnitude of the deficiency is adjusted, single contingency analysis is used to establish the CETL value. The second generation pattern required represents the dispatch of the remainder of PJM and surrounding non-PJM areas, comprised of a much larger number of generators not experiencing any emergency conditions. The larger area in PJM is modeled as experiencing only normal levels of unit outages simulated through a uniform reduction of all on-line generation. The reduction is based on an average Equivalent Forced Outage Rate (EFORd) as that term is defined by NERC standards (<http://www.nerc.com/page.php?cid=4|43|47>) for PJM capacity resources.

Thermal studies to determine potential overload conditions are evaluated using a probabilistic approach whereby up to 10,000 different generation outage scenarios within the study area are simulated to determine an expected value for the various facility loading levels under test at the CETO. Voltage analysis uses a combination of discrete generator outages and scaled generator output under test at the CETO.

## **C.4 PJM Load Deliverability Procedure—Capacity Emergency Transfer Objective (CETO)**

The Capacity Emergency Transfer Objective (CETO) analysis determines a target MW import value for a test area that ensures sufficient transmission capability to access available external capacity reserves. The import value determined is a measure of the transmission capability required by the test area so that the area does not experience a modeled, transmission induced loss of load event more frequently, on average, than 1 in 25 years. This test ensures comparability of transmission service to all areas within the PJM Region.

The CETO for each sub-area in PJM is determined separately using PJM's reliability software to perform a single area reliability study for each load area. The system models are based on the latest RTEP load and capacity data available at the time of the study. Only the load and capacity within the study area are modeled while the capacity supply from outside the study area is assumed unlimited. The transmission system is not modeled. The CETO is the import capability value that is necessary for the study area to achieve the CETO reliability standard. The CETO reliability standard is one event in 25 years.

More detail is available by referring to PJM Manual 20 – Resource Adequacy Analysis at <http://www.pjm.com/documents/manuals.aspx>

## **C.5 PJM Load Deliverability Procedure—Capacity Emergency Transfer Limit (CETL)**

### **1.0 Introduction**

PJM specifies a reliability objective regarding each study area's ability to import needed and available capacity assistance. The purpose of performing a Capacity Emergency Transfer Objective/Limit Study (CETO/CETL) also known as a Load Deliverability study is to verify that this objective is met. Load Deliverability analysis is therefore one of the tests applied to validate the deliverability of PJM capacity resources to PJM load. Load Deliverability analysis is performed for a study area. At present, load deliverability study areas consist of individual zones, sub-zones and the geographical combinations of zones. Eighteen zones and sub-zones have thus far been identified. The zones correspond to the present power flow areas of the PJM operating companies. Five global study areas which are geographical combinations of power flow zones have thus far been identified.

### **2.0 Study Objectives**

The goal of a PJM Load Deliverability study is to establish the amount of emergency power that can be reliably transferred to the study area from the remainder of PJM and the areas adjacent to PJM in the event of a generation deficiency within the study area (the study area's CETL). This transfer limit, in combination with its corresponding CETO, is then used to determine if the import capability required to meet the reliability objective is sufficient. An indicator of the amount of reserve transfer capacity (if any) available is also provided.

### 3.0 General Procedures and Assumptions

#### 3.1 Independent Study Area Generation Capacity Deficiency

For the purposes of analysis, each tested study area within the PJM control area is assumed to be experiencing a generation deficiency independently. Thus, the remainder of PJM and adjacent non-PJM areas are operating normally and are assumed to be able to supply the study area with emergency power up to the limit of their available reserves. Load in all other areas beyond the area under test will be modeled at 50/50 load level reduced by forecast energy efficiency. The amount of reserves considered available from any adjacent non-PJM area may be changed to reflect historical data. Generally the procedure first tests the limit based on PJM reserves. The resource supply is opened to areas external to PJM as necessary, based on a reasonable expectation of such external support.

#### 3.2 Consistency with PJM Emergency Operations Procedures

In all cases, the study area CETL analysis should reflect actual PJM emergency operations procedures designed to make as much power available to the deficient study area as possible under the prevailing system conditions. This should include (but is not limited to):

- The operation of any available PJM generation regardless of system economics.
- The activation of any PJM Load Management (LM) schemes that may serve to unload limiting facilities to the extent that it does not reduce the load in the area under test below expected 50/50 load reduced by forecast energy efficiency levels.
- The modification of any transfers modeled in the base case.
- The adjustment of any Phase Angle Regulators (PARs) which PJM or PJM member companies control (within existing agreements for emergency operation).
- The activation of any approved PJM or PJM member company operating procedure (procedure descriptions are available in Manual 3.)
- Re-dispatch of capacity resources in PJM are allowed internal to the study area to relieve an overload provided that the CETO is increased by the amount of generation re-dispatch required to eliminate the internal overload.

#### 3.3 Study Area Definitions—Zonal and Global

A study area may consist of a single PJM transmission owner's transmission system (230 kV and below for the Mid-Atlantic system) with its connected load and generation. In this case, the study area is referred to as a **Zonal** study area. A study area may also consist of a geographical combination of various transmission systems (with all connected load and generation) sharing common bulk facilities for importing power. For this combination type of study area, a **Global** CETL analysis will be performed in which all load and generation in the area will be modeled internal to the study area. Assessment of both Global and Zonal Load Deliverability analyses will identify the most restrictive emergency import margins with respect to reliability criteria and deliverability of capacity resources.

### **PJM Global CETL Study Areas**

Eastern Mid-Atlantic Area – Comprises all load and generation connected 500 kV and lower in PECO, PSE&G, JCP&L, Delmarva, AE, and RECO.

Southern Mid-Atlantic Area – Comprises all load and generation connected 500 kV and lower in BG&E and PEPCO.

Western Mid-Atlantic Area – Comprises all load and generation connected 500 kV and lower in Penelec, Met-Ed and PP&L.

Mid-Atlantic Region – Comprises all load and generation connected 500 kV and lower in Penelec, Met-Ed, PP&L, BG&E, PEPCO, PECO, PSE&G, JCP&L, Delmarva, AE and RECO.

Western Region – Comprises all load and generation connected 765 kV and lower in ComEd, ATSI, AEP, Dayton, DEOK, Duquesne and AP. Note that CPP is within the ATSI transmission Zone.

### **PJM Zonal CETL Study Areas**

Penelec – All load and generation connected at 230 kV and below.

AP – All load and generation connected at 500 kV and below.

ATSI – All load and generation connected at 345kV and below.

DEOK – All load and generation connected at 345kV and below.

Met-Ed - All load and generation connected at 230 kV and below.

PP&L - All load and generation connected at 230 kV and below.

BG&E - All load and generation connected at 230 kV and below.

PEPCO - All load and generation connected at 230 kV and below.

JCP&L - All load and generation connected at 230 kV and below.

PECO - All load and generation connected at 230 kV and below.

AE - All load and generation connected at 230 kV and below.

PSE&G - All load and generation connected at 230 kV and below.

Delmarva - All load and generation connected at 230 kV and below.

ComEd - All load and generation connected at 765 kV and below.

AEP - All load and generation connected at 765 kV and below.

Dayton - All load and generation connected at 345 kV and below.

Duquesne - All load and generation connected at 345 kV and below.

Dominion – All load and generation connected at 500 kV and below.

Delmarva South - All load and generation connected at 230 kV and below as defined in Figure E-1.

PSE&G North - All load and generation connected at 230 kV and below as defined in Figure E-2.

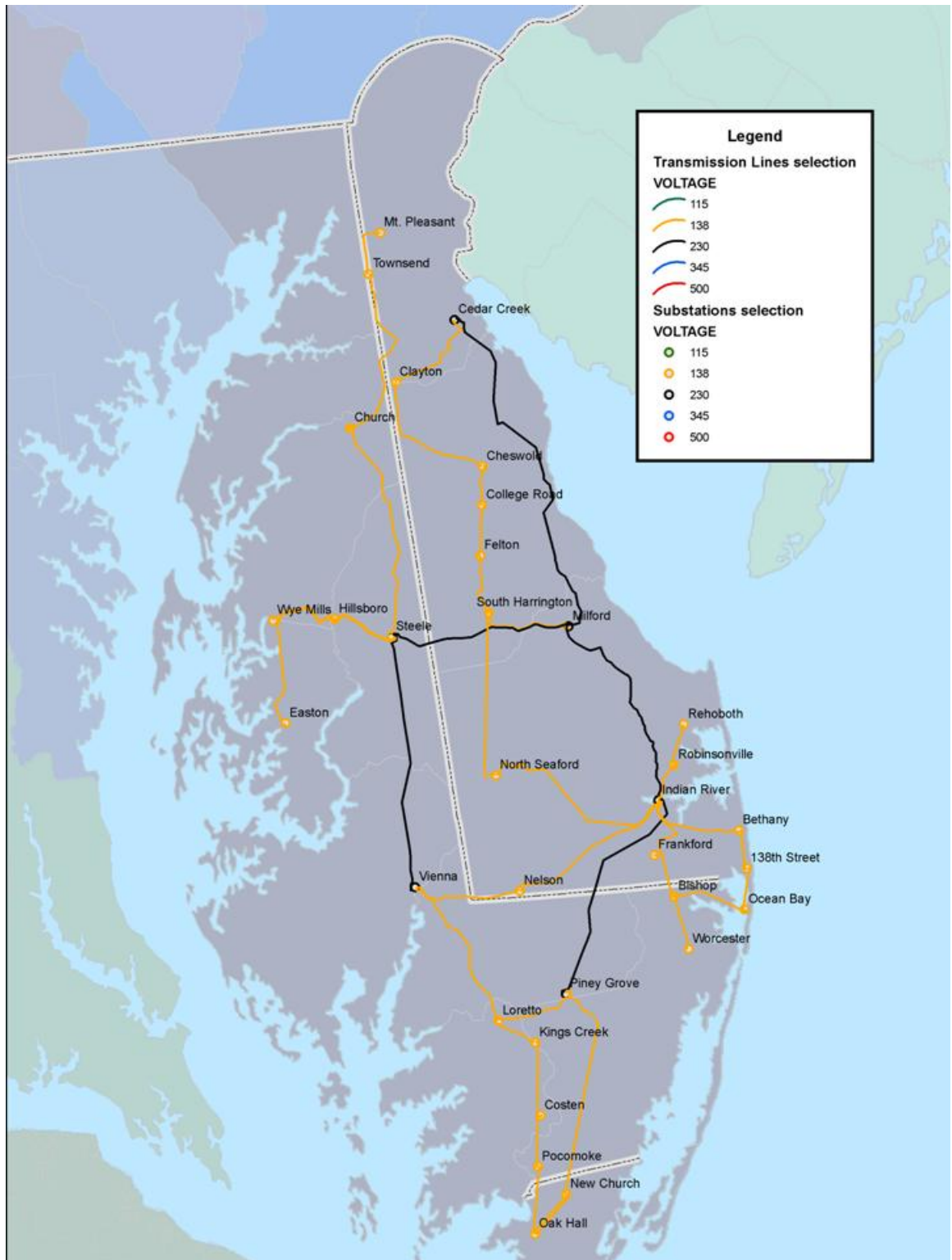

Figure E-1 (Delmarva South)

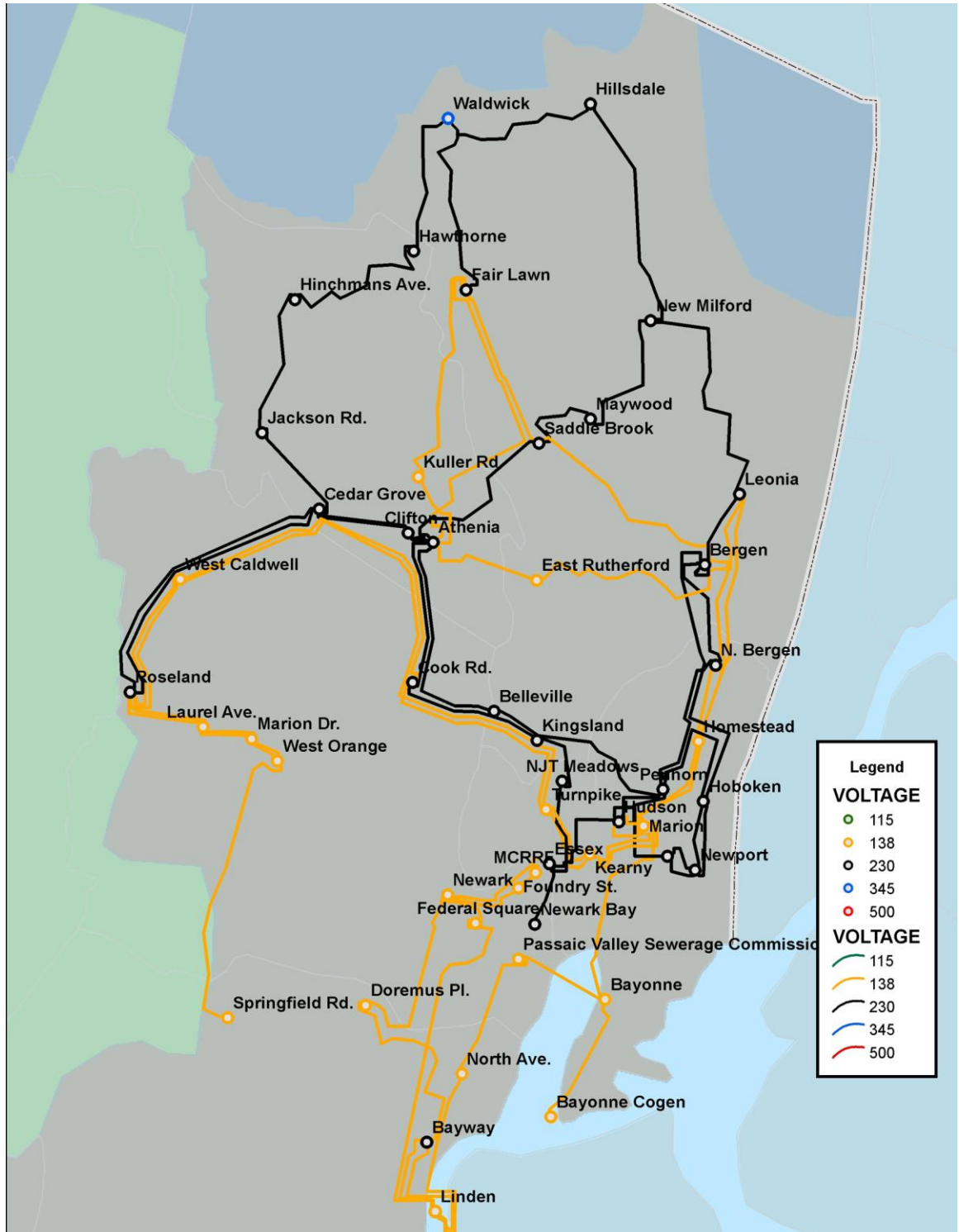

Figure E-2 (PSE&G North)

## 4.0 Base Case Development

Two separate base case models are developed as may be necessary; a PJM summer peak case to study summer-peaking study areas and a PJM winter peak case to study winter-peaking study areas (The need for a winter case is assessed annually. Currently the only PJM winter peaking area has summer and winter peaks sufficiently close to enable the analysis on only a summer peak case). The RTEP load flow case nearest to the study time period should be selected and modified as required (modeling the projected load, generation, and transmission system configuration for the target study period).

To calculate plausible generator outage scenarios, a file containing the installed MW capacity and the Generator Unavailability Subcommittee (GUS) five-year planning equivalent forced outage rate demand (EFORd) for every PJM capacity resource will be developed. Related data is available at <http://www.nerc.com/page.php?cid=4|43|47>.

### 4.1 Study Area Capacity Deficiency Assumptions

The study area being evaluated is assumed to be experiencing the generation deficiency due to a combination of higher-than-expected load demand (a 90/10 load forecast) and greater-than-expected generator unavailability. The 90/10 load forecast level is modeled by using the value of the 90/10 load contained in the latest LAS report along with generator outage scenario(s) that would lead to a generation deficiency which cause a transmission limitation.

### 4.2 Study Area CETL Base Case Modeling Summary

- Behind the Meter and energy only generation should be modeled at the average historic MW output during the previous year's 10 highest load hours for the study area each hour being selected from a different day.
- No study areas will be defined less than a peak load of 1500 MW.
- Generator reactive output will be reduced in proportion to the MW scaling reduction for any generation that is modeled below the rated capability.
- The 90/10 load adder is assumed to be at 0.8 power factor.
- Normal and emergency ratings included in the power flow will be those applied in Operations (at 35°C).
- PAR setting should be 1000 MW to NJ at Ramapo, 1000 MW to NJ at Waldwick, and 1000 MW into ConEd at Goethals and Farragut. PARs located within PJM may be operated as needed subject to the appropriate agreements (if any) and PJM Operating Company practices. Except as follows.
- PAR settings during subsequent contingency analysis can decrease the 1000 MW delivery to ConEd at Goethals and Farragut to as low as 600 MW delivery as required to enhance deliverability to the eastern study areas.
- The forecast 90/10 MW load for the area under test will be reduced by the available energy efficiency and DR (both in MW). The greater of the 90/10 MW load in the area under test reduced by the total amount of energy

efficiency and DR or the 50/50 load reduced by forecast energy efficiency, will be used as the MW load in the area being tested.

- If the 50/50 load reduced by energy efficiency is used to model the load in the test area, the forecast 90/10 MW load reduced by the amount of energy efficiency and DR needs to be adjusted by a MW adder to reach the level of 50/50 MW load minus the energy efficiency. The MVAR load associated with the 50/50 load minus the energy efficiency also needs to be increased by an amount equal to the difference between the MVAR associated with the 90/10 load adder at an 80% power factor and at the power factor in the 50/50 load forecast. The MVAR adder is to account for the assumption that the incremental MW (90/10 load adder) between the 90/10 and 50/50 load forecast is at an 80% power factor.

Note that the above assumes that the 90/10 forecast contains only a MW value. If the 90/10 forecast contains both a MW and a MVAR value, the power factor of this forecast 90/10 load needs to be used for the adjustment instead of the 80% power factor.

#### 4.3 Procedure for Determining Load Deliverability Facility List

The following procedures outline the process for determining which facilities will be monitored for the PJM Load Deliverability test. The first procedure provides the details for internal PJM facilities and the second procedure concentrates on external PJM facilities.

##### Internal PJM Load Deliverability Facility List

1. PJM monitors all transmission facilities for its load deliverability test and screens criteria violations for upgrades that pass a transfer distribution factor (TDF) cutoff test and are on PJM's monitored facility list (Lists of PJM monitored lines and substations are available at <http://www.pjm.com/markets-and-operations/transmission-service/transmission-facilities.aspx>.) PJM performs load deliverability for its entire region by individually studying each study area listed in § 3.3. A different subset of the Transmission Facilities is the focus for each study area.
2. The following defines the TDF cutoff for PJM facilities that will be included in the separate Load Deliverability test for each study area. If a 100 kV and up facility is excluded from all load deliverability analyses based on its unresponsiveness to load supply, that facility may be addressed in generator deliverability or it becomes subject to reliability screening under the standard NERC TPL 001-004 criteria<sup>4</sup>.

All non-radial facilities 345 kV or greater will be included regardless of OTDF.

<sup>4</sup> Any 100 kV and above facility that is not subject to upgrade screening in the load deliverability analysis will be evaluated in a subsequent screening that evaluates the NERC TPL-001 through 004 criteria in the 50/50 peak load scenario. All facilities failing these standard NERC criteria will be identified for upgrade.

All facilities with an external OTDF (an “external OTDF” is based on a source point external to the study area and a sink point internal to the study area) greater than 10% will be included regardless of voltage class.

All facilities with an external OTDF between 5% and 10% will be included unless both PJM and the TO agree that the facility should not be subject to the load deliverability test.

All facilities with an external OTDF less than 5% will not be included unless the PJM and TO agree that the facility should be subject to the load deliverability test.

3. The Load Deliverability Facility List can be modified prior to each baseline analysis but cannot be changed between baseline studies.
4. All PJM monitored facilities will be included when determining any generation re-dispatch or PAR movements required for the base case development. However, only the facilities on the Load Deliverability Facility List will require system upgrade if overloaded for this load deliverability test.
5. The substations to be included for voltage analysis will be developed based on the Load Deliverability Facility List.
6. Additional substations to be included for voltage analysis as agreed to by PJM and the TO.

### **External PJM Load Deliverability Facility List**

For study areas electrically close to PJM, PJM conducts joint coordinated interregional studies on a periodic basis that examines and addresses deliverability issues between PJM and adjacent external systems.

### **4.4 Dispatch for PJM Areas Not in Capacity Emergency**

PJM generators should be dispatched as per existing RTEP base case procedures (see also “Deliverability of Generation”). To simulate the average forced outage rate for generation in PJM, a uniform de-rate of all generation is done.

#### **4.4.1 Dispatch for non-PJM Areas Not in Capacity Emergency**

One of the base principles for the load deliverability test is that the study area is the only area that is in a capacity emergency. All adjacent external areas to PJM are assumed to be at a peak load but in a non-emergency condition. Increasing available generation (respecting Pmax) simulates exports from these areas to the study area.

The locations of generation increases and corresponding MW import level to the study area is typically optimized to provide the highest available imports to any given study area. The import amounts from each external area can be based on strength of ties or historical imports when the study area was capacity deficient. The amount of reserves considered available from any external system may be changed from the optimized scenario to reflect historical import data or to minimize constraints at the discretion of the engineer conducting the study.

## 4.5 Dispatch for Load Deliverability Study Area

### 4.5.1 Procedure to Determine Dispatch for Voltage Analysis

1. Derate all generators in the zone by their EFORD.
2. Rank generators by  $EFORD^{(1/P_{MAX})}$ .
3. To model discrete generator outages, select generators in rank order until the next selected generator would exceed 105% of the target generator outage value.
4. Multiple generators at the same substation may be outaged unless the outaged MW to installed MW ratio is greater than 60%. (For example, if a station had 3-100 MW units, 1 unit would be outaged since  $100 \text{ MW}/300 \text{ MW} = 33\%$  but two units would not be outaged since  $200 \text{ MW}/300 \text{ MW} = 66\%$ )
5. Any remaining MW outages required to meet the target generator outage value will be obtained through a uniform scale of all on-line generation's MWs and MVARs in the study area.
6. The Transmission Owner(s) may request analysis of a different outage pattern. If this outage pattern results in more severe reliability problems it will be used in place of the original outage pattern only if both the Transmission Owner and PJM accept the new outage pattern.

### 4.5.2 Procedure to Determine Dispatch for The Mean Dispatch Case

1. All generators in the study area are sampled until 10,000 generation outage scenarios are found where the amount of generation selected is within +/- 2% of the amount needed to meet the target generator outage value required to model the import objective.
2. The 10,000 generation outage scenarios are determined by using a Monte Carlo simulation and randomly assigning a value between 1 and 0 to each generator in the study area. If the value is greater than the generator forced outage rate, then that generator is turned on. If the value is less than the generator forced outage rate, then that generator is turned off. There is no limit to the number of units that can be simultaneously outaged at a station.
3. Determine the average MW output of each generator in the study area by using its dispatched values in the 10,000 generator outage scenarios. These average MW output values for each generator are referred to as the Mean Dispatch.
4. The reactive capability of each unit is reduced by the ratio of each unit's average MW output from the preceding step to the unit's maximum MW output.
5. Create a base case modeling the average MW output of each generator determined in step 3 above. This case is referred to as the mean dispatch case. It models a generation outage scenario based on the average MW for each unit from the 10,000 generation outage scenarios determined in step 3 above. This case is used by the entities to study potential

reinforcements required to resolve any overloaded flowgates. In addition, since the case models an average generation outage scenario and therefore average losses for those outage scenarios, it is the best case to use when determining the impact on flowgates of the various discrete generation outage scenarios applied for the median loading.

6. Perform an AC contingency analysis on the mean dispatch case to obtain the percent loading for each flowgate. This percent loading is referred to as the reference loading.
7. Flowgates that have a reference loading greater than or equal to 90% of the appropriate (i.e., normal or emergency) rating (at 35°C) in the mean dispatch case are tested further as defined below.
8. To determine the discrete generation outage scenarios, all generators in the study area are sampled until 10,000 generation outage scenarios are found where the amount of generation selected is within +/- 2% of the amount needed to meet the target generator outage value required to model the import objective. (This process is described in steps 7 and 8 above).
9. The flowgate loading for each discrete generation outage scenario is determined as follows:
  - a. For each generator in the study area, a distribution factor is established for each flowgate using the generator in the study area as the sink point and all generators external to the study area, being used to model the transfer as the source points.
  - b. The impact on the flowgate due to the change in generation is determined for each generator by determining the change in MW output in the generation outage scenario from the output modeled in the mean dispatch case. The change in MW value is then multiplied by the distribution factor of each flowgate to determine the +/- impact on the flowgate.
  - c. The AC MVA loading from the mean dispatch case is incremented or decremented by this MW result.
  - d. This results in 10,000 percentage loadings being established for each flowgate (i.e., one flowgate percent loading for each of the generation outage scenarios studied).
10. If any overloads exist, any of the system adjustments noted in section 3.2 can be implemented and the procedure in section 4.5.2 is repeated.
11. Any overloads that still remain will require mitigation in order for the study area CETL to exceed the CETO.

#### 4.6 Study Results

1. Five % points are selected (30-70% in 10% increments) to quantify the probability of a given % loading for each flowgate.
2. For example, a 90% flowgate loading in the column of the first point, 30%, means that in 3,000 of the 10,000 discrete generation outage scenarios

the line loading was below 90%. Likewise, a 90% flowgate loading in the column of the third point, 50%, means that in 5,000 of the 10,000 discrete generation outage scenarios the line loading was below 90%. This third point is the median flowgate loading.

3. Select 50% probability point such that any circuits with loadings exceeding their applicable rating for more than 50% of the dispatch scenarios will require upgrade.

#### **4.7 CETL Determination**

After steps 4.5.1 and 4.5.2 are completed and any required system upgrades are identified to eliminate any voltage problems or overloads, the study area CETL can be determined.

##### **CETL for Voltage Problems**

To determine the CETL for voltage problems, the imports into the study area will be increased in 50 MW increments starting from the dispatched base case identified in section 4.5.1. The import change will be modeled by increasing external generation and uniformly decreasing internal study area generation.

##### **CETL for Thermal Problems**

To determine the CETL for thermal problems, the transfer distribution factor on each of the flowgates will be calculated by using a source of generation external to the study area and a sink of generation internal to the study area. The transfer distribution factor multiplied by the increased imports will indicate which overload will limit the study area imports from a thermal perspective.

##### **CETL for Study Area**

The lower of the CETL identified for the voltage problems and the thermal problems will be used as the study area CETL.

#### **5.0 Transitional Rules**

This Load Deliverability Procedure will be applied for all future load deliverability analysis for planning years 2008 and beyond. Any existing projects identified through the RTEP for installation prior to June 2008 and approved by the PJM Board will remain requirements as identified in previous analysis.

### **C.6 Deliverability of Generation**

The second deliverability test, the ability of an electrical area to export capacity resources to the remainder of PJM has historically been applied in situations where problems were expected to occur. Consistent with the move from IOU service territories to electrical areas, this test is applied to ensure that capacity is not "bottled" from a reliability perspective. This would require that each electrical area be able to export its capacity, at a minimum, during periods of peak load. Export capabilities at lower load levels would be based more on economic decisions and would not reflect on deliverability criteria and therefore the "certification" of resources as deliverable capacity.

Deliverability, from the perspective of individual generator resources, ensures that, under normal system conditions, if capacity resources are available and called on, their ability to provide energy to the system at peak load will not be limited by the dispatch of other

certified capacity resources. This test does not guarantee that a given resource will be chosen to produce energy at any given system load condition. Rather, its purpose is to demonstrate that the installed capacity in any electrical area can be run simultaneously, at peak load, and that the excess energy above load in that electrical area can be exported to the remainder of PJM, subject to the same single contingency testing used when examining deliverability from the load perspective. In short, the test ensures that bottlenecked capacity conditions will not exist at peak load, limiting the availability and usefulness of certified capacity resources to system operators. In actual operating conditions, energy-only resources may displace capacity resources in the economic dispatch that serves load. This test would demonstrate that a magnitude of resources equal to or greater than the installed capacity in any given electrical area could simultaneously deliver energy to the remainder of PJM. Therefore, these tests do not require the calculation of the equivalent of export CETO and CETL values.

The electrical Regions from which generation must be deliverable, range from individual buses to the entire regional generation under study. The premise of the test is that all capacity within the Region is required; hence the remainder of the system is experiencing a significant reduction in available capacity. However, since localized capacity deficiencies reductions are tested when evaluating deliverability from the load perspective, the dispatch pattern in the remainder of the system is modeled based on a uniformly distributed outage pattern.

## C.7 Generator Deliverability Procedure

### 1.0 Introduction

To maintain reliability in a competitive capacity market, resources must contribute to the deliverability of the Control Area in two ways. First, energy must be deliverable, from the aggregate of resources available to the Control Area, to load in portions of the applicable PJM region experiencing a localized capacity emergency, or deficiency. PJM utilizes the CETO / CETL procedure to study this “deliverability of load”. Second, capacity resources within a given electrical area must, in aggregate, be able to be exported to other areas of PJM that are experiencing a capacity emergency. PJM utilizes a Generator Deliverability procedure to study the “deliverability of individual generation resources”. This document provides the procedure for Generator Deliverability.

### 2.0 Study Objectives

The goal of the PJM Generator Deliverability study is to determine if the aggregate of generators in a given area can be reliably transferred to the remainder of PJM. Any generators requesting interconnection to PJM must be “deliverable” in order to be a PJM installed capacity resource.

### 3.0 General Procedures and Assumptions

#### **Step 1: Develop Base case**

The RTEP base case is developed for a reference year 5 years in the future. All RTEP identified system upgrades and Supplemental RTEP Projects are included in the system model. Load is modeled at a non-diversified forecasted 50/50 summer peak load level reduced by energy efficiency as per the latest load forecast. All approved firm interchange is included with roll-over rights. Generation and Merchant Transmission projects that have

proceeded at least through the execution of the Facility Study Agreement stage of the interconnection process are considered in the model along with any associated network upgrades. The starting point dispatch is developed as explained in the next step. PJM uses a uniform reduction of generation in place of discrete forced outages for this test due to the significant bias any one specific outage pattern can have on the final overload results.

### **Step 2: Establish initial RTEP dispatch for unit under study**

Place all in-service capacity resources (those that have procured capacity delivery rights) on-line at a generation value equal to their installed capacity x (1 – PJM average EEFORd). Wind units with capacity delivery rights are derated to their granted capacity rights (either 13% beginning with the “U” queue or 20% for prior queues) representing the combined effects of wind variation and outage characteristics. The target generation value is the projected load + losses + firm interchange. (See addendum 1 for treatment of transmission withdrawal and injection rights). If all in-service capacity resources de-rated by the PJM EEFORd are greater than the target generation value, then all in-service capacity resources should be uniformly reduced to meet the target generation value. If all in-service capacity resources de-rated by the PJM EEFORd is less than the target generation value, then place all capacity resources with an executed Interconnection Service Agreement (ISA) on-line at a generation value equal to the installed capacity x (1 – PJM average EEFORd). If all in-service and ISA capacity resources de-rated by the PJM EEFORd are greater than the target generation value, then all these resources should be uniformly reduced to meet the target generation value. If all in-service and ISA capacity resources de-rated by the PJM EEFORd is less than the target generation value, then place all capacity resources with an executed Facility Study Agreement on-line at a generation value equal to the installed capacity x (1 – PJM average EEFORd). If all in-service, ISA and Facility Study capacity resources de-rated by the PJM EEFORd are greater than the target generation value, then all these resources should be uniformly reduced to meet the target generation value.

All resource requests in the study queue ahead of the unit under study are set at 0 MW but available to be turned on. The resource request under study is also set at 0 MW but available to be turned on. Resource requests queued after the unit under study are not modeled. The loading on each transmission line that results from this dispatch and the application of a contingency is the base loading of the facility. (See Addendum 2 for treatment of Common Mode Outage Procedures).

### **Step 3: Determine potential overloads**

PJM uses a linear (DC) power flow program to analyze each facility for which PJM is responsible to determine whether any contingencies can overload the facility (including comprehensive analysis of single, towerline, bus, and stuck breaker contingencies). These results are utilized to determine which flowgates will be used in the generator deliverability analysis, i.e., the program examines each PJM flowgate (contingency / monitored element pair) on the entire PJM footprint. The procedure below explains conceptually how the program works; following the procedure below would yield the same results as the program. The procedure uses a load flow set up according to step 2.

Determine the distribution factor for each generator on each flowgate. The distribution factor for a particular generator is referenced to the PJM online generation. For each flowgate, multiply the distribution factor of each generator by the offline portion of the generator to obtain the MW impact the generator would have on a particular flowgate if it were ramped from its output in the initial load flow to its full output. This result will be referred to the

ramping impact of a particular generator on a particular flowgate. For all flowgates determine the cumulative ramping impact of generators with greater than a 1% distribution factor. The total amount of ramped generation is capped to limit the number of potential overloads to a reasonable number of the worst impacts. A typical cap for the total ramping is 10,000 MW but the actual value can vary to establish a reasonable scope for the potential overloads. For each flowgate, add the cumulative ramping impact to the initial DC loading. If the resulting DC loading is greater than the flowgate rating, then this flowgate is a potential overload.

#### **Step 4: Determine 80/20 DC loading**

The number of generators having greater than a 1% distribution factor in Step 2 is often large enough that having them all simultaneously outputting their full installed capacity would be extremely improbable. As a result, in this step the number of generators contributing to the cumulative ramping impact on a flowgate is further restricted in the following manner.

Units modeled in the power flow with greater than a 5% distribution factor (or 10% distribution factor for flowgates whose monitored element's highest terminal voltage level is equal to or greater than 500 kV) that contribute to the cumulative ramping impact are ranked according to their distribution factor on a potentially overloaded flowgate. The availability (1 – EEFORD) of the unit with the highest distribution factor is then multiplied by the availability of the unit with the second highest distribution factor and so on until the expected availability of the selected units is as close to but not less than 20%. This resulting "80/20" cumulative ramping impact is then added to the initial DC loading on the flowgate. This resulting loading is the 80/20 DC loading and the generators chosen to contribute to the cumulative ramping impact are the 80/20 generators.

#### **Step 5: Determine Facility Loading Adder**

This Step 5 addresses off-line generators which are not included in the 80/20 list. Existing generators that do not have capacity delivery rights and active queued generators that are not yet in commercial operation (or do not yet have a signed ISA) are offline but available to be turned on. The ramping impact of this set of generators determines the Facility Loading Adder. First, for their ramping impact to be considered, off-line generators must pass the impact threshold of at least a 5% DFAX (10% for flowgates with monitored elements having the highest terminal voltage 500 kV and above) on a flowgate or with an impact (DFAX times a generator's full energy output rating) greater than 5% of the flowgate's rating.

The ramping impact of offline generators is determined according to their classification as: (1) existing generators that do not have capacity delivery rights and active queued generators with signed ISA's, or (2) active queued generators without signed ISA's. Category (1) generators are allowed to aggravate or backoff overloaded flowgates. Category (2) generators are considered only if they aggravate overloaded flowgates (active queued generators without signed ISAs are not allowed to backoff overloads.)

For each potential flowgate, an approximated CETO will be calculated by finding a receiving end area. The receiving end area will include:

- Load buses with a positive impact on flowgate loading
- Generators with negative impact on flowgate loading

The estimated CETO will be calculated using the following function:

$$\text{Estimated CETO} = 1.08 * (\text{Bus Loads} + \text{Losses} - \text{Diversity} - \text{Demand Response}) - (1 - 1 * \text{Avg. EEFORD}) * \text{ICAP} + \text{Largest Unit}$$

Each receiving end area will be assigned a portion of the PJM Capacity Benefit Margin (CBM) based on the receiving end area's share of the PJM load. CBM will be used to offset generators that contribute to the Facility Loading Adder when the import level for a receiving end area becomes greater than:

(receiving end area estimated CETO - receiving end area CBM allocation)

To ensure that new generators within small clusters of the electrically closest generation to a flowgate will not be offset by the delivery cap, an exception to the CBM offset will be made. Generators which contribute to the Facility Loading Adder and have distribution factors that fall outside of two standard deviations of the mean of all PJM generator distribution factors will be available to contribute to the Facility Loading Adder. The amount of generation change from the initial load flow due to changes in 80/20 and Facility Loading Adder generation shall not be any more than the online installed capacity exclusive of the 80/20 generators  $\times$  PJM average EEFord. This rule is enforced by curtailing generators that contribute to the Facility Loading Adder. In order to always maintain a critical system condition for this deliverability test, the 80/20 or 50/50 generation, as applicable, will not be curtailed to enforce this rule.

The ramping impact of active queued generators without signed ISA's considers the commercial probability of queued generators at the feasibility and impact study stage of the interconnection process. For generators at the feasibility study stage of the interconnection process, the output of the generator is multiplied by the historic commercial probability of a generator at the feasibility study stage of the interconnection process. For generators at the impact study stage of the interconnection process, the output of the generator is multiplied by the historic commercial probability of a generator at the impact study stage of the interconnection process. To be conservative, these values are then multiplied by 150% to determine the ramping impact of generation at the feasibility study and impact study stage of the interconnection process. The entire requested capacity of queued generation is used to determine the ramping impact of generation that has signed a facility study agreement.

The summation of 85% (100% for a Merchant Transmission project) of the ramping impact on a flowgate of each off-line resource that meets the above conditions is calculated. The resulting impact defines the Facility Loading Adder. The Facility Loading Adder is added to the base loading and the 80/20 DC loading to obtain the final DC loading on the facility.

#### **Step 6: Determine Final Flowgate Loading**

If a flowgate has a final DC loading less than 90% of its rating, it is not considered to be overloaded and is not tested further. If a flowgate has a final DC loading greater than or equal to 90% of its rating, the 80/20 generators are ramped up to their installed capacity in the load flow from step 2 and all remaining PJM generators are uniformly ramped down such that the PJM firm interchange is maintained. The resulting flowgate loading is the 80/20 AC loading.

The Facility Loading Adder can sometimes have a significant impact on the results of a deliverability study. However, ramping up the units associated with the adder in the load flow will typically create too much localized generation and a localized capacity emergency condition elsewhere when the rest of PJM is proportionally displaced to maintain the firm

interchange. Therefore, to account for the effect of these units on the facility in question, the Facility Loading Adder, as determined in Step 5, is added to the 80/20 AC loading to result in the Final Flowgate Loading. This Facility Loading Adder accounts for the ramping impact of those offline resource requests that are both electrically close to a flowgate and did not participate as an 80/20 generator without actually turning them on. If the cumulative ramping impact of these offline resource requests has a beneficial effect on the flowgate, then the loading of the flowgate will be decreased to account for this beneficial effect. Similarly, the flowgate loading will be increased if these offline resource requests will further add to the overload.

In summary, the 80/20 generators will define the study area *for a particular flowgate* by determining which units to ramp up. All remaining online units are proportionally displaced to some level below their installed capacity  $\times (1 - \text{PJM average EEFORd})$  to maintain the firm PJM interchange.

### **Addendum 1: Modeling Transmission Withdrawal Rights (TWRs) and Transmission Injection Rights (TIRs)**

Firm TWRs and TIRs may be associated with a controllable merchant transmission request, i.e. HVDC, which interconnects PJM to another system. If the transmission request has an executed ISA associated with it, the firm rights are modeled at their full amount. When the firm rights are modeled, the initial dispatch in step 2 will need to be modified to support these rights. If the transmission request does not have an executed ISA and is queued ahead of the project under study or is the project under study the following rules apply; for TWRs the sign of the distribution factor is changed for the purpose of deciding whether to model the right. The right is modeled at its full amount if a generator with its distribution factor would be in the 80/20 list. The right is treated as a Facility Loading Adder using the rules of Step 5.

### **Addendum 2: Common Mode Outage Procedure**

In addition to single contingencies, PJM planning criteria requires that the PJM system withstand certain common mode outages. These outages include line faults coupled with a stuck breaker, double circuit towerline outages, faulted circuit breakers and bus faults. PJM uses a procedure very similar to the generator deliverability procedure to study common mode outages. The list below highlights the other details of the common mode outage procedure that differ from the generator deliverability procedure.

In addition to the modeling of capacity resource requests, all existing energy resources and energy resource requests queued ahead of the unit under study are set at 0 MW but available to be turned on. The energy resource request under study is also set at 0 MW but available to be turned on. Energy resource requests queued after the unit under study are not modeled.

A 50/50 DC loading is used instead of an 80/20 DC loading, i.e., the expected availability of the selected units is close to but not less than 50%.

For all voltage levels, a 10% distribution factor is used instead of a 5% distribution factor to select the 50/50 generators.

## Attachment D: PJM Reliability Planning Criteria

The PJM Reliability Planning Criteria consist of multiple standards and applicable planning principles that include PJM planning procedures, NERC Planning Standards, NERC Regional Council planning criteria, and the individual Transmission Owner FERC filed planning criteria. PJM applies all applicable planning criteria when identifying reliability problems and determining the need for system upgrades on the PJM system. Details of specific criteria applicable to the various stages of reliability planning are discussed along with the corresponding discussion of each procedure found elsewhere in this manual.

- I. The PJM Transmission Owners are required to follow NERC and Regional Planning Standards and criteria as well as the Transmission Owner FERC filed criteria. References to the various planning standards and criteria can be found at: [PJM - NERC and Regional Compliance](#) and <http://www.pjm.com/planning/planning-criteria.aspx>.
  - ReliabilityFirst Approved Standards will be applied for all ReliabilityFirst Bulk Electric System facilities.
  - SERC Reliability Criteria will be applied to all SERC networked transmission systems rated 100 kV and higher.
  - Transmission Owner standards filed in their FERC 715 filings will be applied to all facilities included in the PJM Open Access Transmission Tariff facility list. Also, interconnections to Transmission Owner facilities are subject to owner standards found at: <http://www.pjm.com/planning/design-engineering.aspx> (these are technical interconnection requirements and do not factor into near-term and long-term planning analyses).

PJM maintains a list (<http://www.pjm.com/markets-and-operations/transmission-service/transmission-facilities.aspx>) of all PJM Open Access Transmission Tariff facilities along with which facilities are included in the PJM real-time congestion management control facility list. Both facility lists are referenced in the PJM Reliability Planning Criteria.

- II. The PJM Generator Deliverability Procedure and Load Deliverability Procedure will be applied to all facilities in the PJM real-time congestion management control facility list.
- III. Facilities included in the PJM real-time congestion management control facility list but not included in the applicable regional council planning criteria as defined in section I above will be evaluated against the following criteria. For all tests, PJM will not accept a planned loss of load of more than 300 MW. Attachment D-1 contains a description of the various load loss types referred to in this document. This criterion is in addition to, not in place of, each Transmission Owners Planning Criteria as reported in the FERC 715 filing.
  1. The loss of any single transmission line, cable, generator, or transformer may not result in any monitored facility exceeding the applicable emergency rating or applicable voltage limit. (The applicable emergency rating and voltage limits will be as defined in PJM Operations.) The single contingency test will be applied as per the RTEP Generator Deliverability Procedure. (See Attachment C of this PJM Manual 14B.)

- The RTEP base case which includes a 5-year horizon system representation and non-diversified forecasted 50/50 summer peak load will be used for this analysis.
  - System load will be represented at an area or zone wide minimum power factor of 0.97 lagging as measured at the transmission / distribution interface point.
  - The 300 MW load limit referenced above does not include load that is immediately restored via automatic switching to adjacent substations.
  - Automatic or supervisory switching as proposed by the Transmission Owner to sectionalize the system for single contingency events must receive acceptance by PJM Operations.
  - During normal conditions with all facilities initially in-service, no uncontrolled load loss or load loss due to automatic schemes is allowed for a single contingency event. Consequential load loss is allowed.
2. After the occurrence of the transmission line, cable, generator or transformer outage, the system must be capable of re-adjustment such that no facility exceeds the maximum continuous rating or voltage limits as defined in PJM Operations.
  3. During maintenance of any single transmission line, cable, generator, transformer, bus or circuit breaker, the loss of a transmission line, cable, generator, or transformer may not result in any monitored facility exceeding the applicable emergency rating or voltage limit (The applicable emergency rating and voltage limits will be as defined in PJM Operations.) However, for practical purposes, PJM Planning will only include a specific bus or circuit breaker maintenance condition in all future analysis if PJM Operations experiences operational problems as a result of the bus or circuit breaker maintenance condition.
    - Pre-contingency generation redispatch will be considered acceptable for mitigation of a potential overload or voltage limit.
    - This test will be applied at 70% of the diversified forecasted 50/50 summer peak load, as modeled in the RTEP base case, unless the Transmission Owner provides information to PJM Operations demonstrating sufficient maintenance windows at a lower load level.
    - No cascading or uncontrolled load loss is allowed under any circumstance.
    - Consequential load loss is allowed.
  4. After occurrence of the maintenance outage and the subsequent facility outage as defined in the previous test #3, the system must be capable of re-adjustment such that no facility exceeds the maximum continuous rating or voltage limits as defined in PJM Operations.

IV. The PJM Light Load Reliability Analysis Procedure will be applied to all facilities in the PJM real-time congestion management control facility list.

## Attachment D-1: Load Loss Definitions

**Uncontrolled Load Loss** – Uncontrolled load loss would require operator interaction to prevent system cascading or to return the system to applicable ratings or voltage limits. Manual load dump as defined in PJM Operations would be included in this category. The PJM Reliability Planning Criteria does not allow for the system design to permit Uncontrolled Load Loss for any contingencies that are studied.

Examples:

- Voltage collapse
- A facility overload without automatic schemes to drop load and with no available generation to re-dispatch pre-contingency.

**Consequential Load Loss** – Consequential load loss occurs due to the design of the system but does not include automatic schemes designed to drop load under various conditions.

Examples:

- A transformer serving radial load that taps a networked circuit.
- Load that is served from a radial circuit.

**Controlled Load Loss due to Automatic Schemes** – Controlled load loss occurs due to the operation of automatic schemes that are designed to drop load under specific maintenance conditions.

**Planned Load Loss** = Consequential load loss + Controlled load loss due to automatic schemes.

The 300 MW total load loss limit is based, in part, on a Federal reporting requirement for major system incidents on electric power systems (refer to Electric Power System Emergency Report - Form EIA-417R).

## Attachment D-2: PJM Reliability Planning Criteria Methods

### D-2.1 Light Load Reliability Analysis

The light load reliability analysis tests the ability of an electrical area to export generation resources to the remainder of PJM during light load conditions. The export generation is selected by using the historical mix of generation that operates at the light load level. This test is applied to ensure that generation capability, including renewable generation capability that typically operates at light load such as wind, pumped hydro, or other emerging storage technologies are not "bottled" from a reliability perspective.

The light load reliability analysis, from the perspective of individual generator resources, ensures that, under light load system conditions, their ability to provide energy to the system has a probability of not being limited by the typical dispatch of other generation resources that operate at that demand level, including resources in neighboring systems. The Generator Deliverability Test and Common Mode Outage procedure have a similar objective at the summer peak forecast load. While deliverability under all possible system conditions is not in the purview of the RTEP, analyzing the system performance under this wide range of forecasted demand levels improves overall deliverability of generating resources. Consideration will be given to the capacity factor by fuel class during this period, as described in Table 1. This test does not guarantee that a given resource will be able to deliver energy at the light load condition. Rather, the purpose is to demonstrate that typical light load generating capabilities in any electrical area can be run simultaneously, at light load, and that the excess energy above demand in that electrical area can be exported to the remainder of PJM. In short, the test ensures that bottled capability conditions will not exist at light load, limiting the availability and usefulness of a range of resources available to system operators, including renewable resources. In actual non-emergency operating conditions, the economic dispatch serves load.

### D-2.2 Light Load Reliability Analysis Procedure

#### 1.0 Introduction

To maintain reliability and operational flexibility during the light load period, resources within a given electrical area must, in aggregate, be able to be exported to other areas of PJM. PJM utilizes a Light Load Reliability Analysis procedure to study the system performance during typical light load conditions. This document provides the procedure for Light Load Reliability Analysis.

#### 2.0 Study Objectives

The goal of the PJM Light Load Reliability Analysis study is to determine if the aggregate of generators in a given area can be reliably transferred to the remainder of PJM during light load conditions. Generators requesting interconnection to PJM must pass this test in order to become a PJM capacity or energy resource.

#### 3.0 General Procedures and Assumptions

### **Step 1: Develop Base case**

The RTEP base case is developed for a reference year 5 years in the future. All RTEP identified system upgrades and Supplemental RTEP Projects are included in the system model. PJM load is modeled at 50% of a non-diversified forecasted 50/50 summer peak load level reduced by energy efficiency as per the latest load forecast. System Interchanges will be determined by PJM through the use of data, including statistical averages based on historical data for off-peak load periods for typical previous years. Generation and Merchant Transmission projects that have proceeded at least through the execution of the Facility Study Agreement stage of the interconnection process are considered in the model along with any associated network upgrades. The starting point dispatch is developed as explained in the next step. PJM uses a combination of uniform reduction of coal powered generation and discrete outages for this test.

### **Step 2: Establish initial RTEP dispatch for unit under study**

**Existing PJM Resources:** Place all in-service nuclear resources on-line at a generation value equal to their installed capacity. Wind units are derated in the initial dispatch to 40% of their nameplate capability. Coal units are initially derated consistent with Table 1. Queued Units in the PJM queue that have an ISA will be placed on-line consistent with Table 1. The target generation value for each Transmission Owner (TO) zone in the model is the projected load + losses + historical interchange for the light load period, as calculated by PJM. If necessary, coal resources in each TO zone are then uniformly de-rated or increased from the initial dispatch until the target generation value is met.

**Existing MISO Resources:** Model all existing wind generation in the MISO area online at a 100% capacity factor. Sink all MISO generation uniformly to maintain the target interchange. MISO generation dispatch utilized to serve MISO load will reflect a typical yearly statistical average for off-peak periods for interchange between MISO West, Central, and East.

**Queued Resources in PJM and neighboring systems:** Model all non-ISA queued generation offline. Model all ISA queued generation online. If selected by the test procedure, queued MISO wind resources will have the potential to be dispatched to 100% capacity factor. Similarly, if selected by the test procedure, queued PJM wind resources will have the potential to be dispatched to 80%.

For queued interconnection studies, all queued resources in the study queue ahead of the unit under study are set at 0 MW but available to be turned on per the Generator Deliverability procedure and Common Mode Outage test procedure. The resource request under study is also set at 0 MW but available to be turned on. Resource requests queued after the unit under study are not modeled. The loading on each transmission line that results from this dispatch and the application of a contingency is the base loading of the facility. (See Addendum 2 for treatment of Common Mode Outage Procedures).

**Table 1 – Light Load Base Case**

Network Model	Current year + 5 base case
Load Model	Light Load (50% of 50/50 summer peak)
Capacity Factor for Base Generation Dispatch for PJM Resources (Online in Base Case)	Nuclear – 100% Coal >= 500 MW – 60% Coal < 500 MW – 45% Oil – 0% Natural Gas – 0% Wind – 40% All other resources – 0% Pumped Storage – full pump
Capacity Factor for Base Generation Dispatch for MISO Resources (Online in Base Case)	Wind – 100%
Interchange Values	Historical values
Contingencies	NERC Category A, B, C (except C3)
Monitored Facilities	All PJM market monitored facilities

**Step 3: Determine potential overloads**

The method to determine potential overloads is similar to the methods used for the generator deliverability test. Also, the Common Mode Outage procedure is applied to include the effects NERC Category C events such as bus faults, faulted breakers, and double circuit towerline outages.

**Step 4: Determine 80/20 DC loading**

This portion of the test is the generator deliverability procedure except only wind generation is considered with a maximum ramping from the base dispatch of 40% to 80% of nameplate capability.

**Step 5: Determine Facility Loading Adder**

This portion of the test is the generator deliverability procedure except only wind generation is considered with a maximum ramping from the base dispatch of 40% to 80% of nameplate capability.

**Step 6: Determine Final Flowgate Loading**

This portion of the test is the generator deliverability procedure except only wind generation is considered with a maximum ramping from the base dispatch of 40% to 80% of nameplate capability.

## Attachment E: Market Efficiency Analysis Economic Benefit / Cost Ratio Threshold Test

PJM uses a Benefit/Cost Ratio test to determine whether an economic-based enhancement or expansion will be included in the RTEP. Specifically, to be included in the RTEP recommended to the PJM Board of Managers for approval, the relative benefits and costs of the economic-based enhancement or expansion must meet a Benefit/Cost Ratio Threshold of at least 1.25:1. The Benefit/Cost Ratio is calculated by dividing the present value of the total annual benefit for each of the first fifteen years of the life of the enhancement or expansion by the present value of the total annual cost for each of the first fifteen years of the life of the enhancement or expansion. Assumptions for determining the present value of the benefits and costs (e.g. discount rate and annual revenue requirement) will be among the assumptions that are approved by the PJM Board each year to be used in the economic planning process.

The Benefit/Cost Ratio is expressed as follows:

$$\text{Benefit/Cost Ratio} = [\text{Present value of the Total Annual Enhancement Benefit for each of the first 15 years of the life of the enhancement or expansion}] \div [\text{Present value of the Total Enhancement Cost for each of the first 15 years of the life of the enhancement or expansion}]$$

The purpose of a Benefit/Cost Ratio Threshold is to hedge against the uncertainty of estimating benefits in the future and to provide a degree of assurance that a project with a 15-year net benefit near zero will not be approved. At the same time the threshold is not so restrictive as to unreasonably limit the economic-based enhancements or expansions that would be eligible for inclusion in the RTEP.

### E.1 Total Annual Enhancement Benefit

The benefit component of the Benefit/Cost Ratio (Total Annual Enhancement Benefit) is the sum of two metrics: the “Energy Market Benefit” and the “Reliability Pricing Model (RPM) Benefit.” By including these two metrics, the benefits to customers from reductions in both energy prices and capacity prices as a result of an economic-based enhancement or expansion will be taken into account in the formulaic analysis. These two metrics in turn each consist of two elements -- the change in production cost and the change in load payment, which are weighted seventy percent and thirty percent respectively. This comprehensive test captures customers’ benefits in the energy markets and the capacity markets that may correspond to responsibilities related to obtaining reasonably priced energy as well adequate capacity.

#### a. Energy Market Benefit

The energy-market benefit analysis is conducted using an energy market simulation tool that models the hourly least-cost, security-constrained commitment and dispatch of generation over a future annual period. A detailed generation, load, and transmission system model is used as input into the simulation tool in order to mimic the hourly commitment and dispatch of generation to meet load, while recognizing constraints imposed on the economic commitment and dispatch of generation by the physical limitations of the transmission system. Benefits of potential economic-based enhancements, PJM will perform and compare market simulations with and without the proposed enhancement for selected future

years within the planning horizon of the RTEP. A comparison of these simulations will identify the annual economic impact of the enhancement for each of the future study years. An extrapolation of these results provides a projection of annual benefits for each of the first fifteen years of the life of the enhancement.

The Energy Market Benefit component of the Benefit/Cost Ratio is expressed as:

$$\text{Energy Market Benefit} = [.70] * [\text{Change in Total Energy Production Cost}] + [.30] * [\text{Change in Load Energy Payment}]$$

The Change in Total Energy Production Cost is the difference in estimated total annual fuel costs, variable O&M costs, and emissions costs of the dispatched resources in the PJM Region without and with the enhancement or expansion.

The Change in Load Energy Payment is the difference between the annual sum of the hourly estimated zonal load megawatts for each PJM transmission zone multiplied by the hourly estimated zonal Locational Marginal Price for each PJM transmission zone without and with the economic-based enhancement or expansion. In determining the Change in Load Energy Payments for projects, the costs of which will be assigned cost responsibility on a regional basis (e.g. above 500 kV facilities), the Load Energy Payment in all PJM transmission zone will be considered whether there is an increase or decrease in the Load Energy Payment in the transmission zone. However, for projects, the cost of which will be allocated using a flow-based or distribution factor methodology (e.g. below 500 kV facilities), only the Load Energy Payment in the PJM transmission zones that show a decrease will be considered in determining the Change in Load Energy Payments.

#### **b. Reliability Pricing Model Benefit**

Reliability pricing benefit analysis is conducted using the Reliability Pricing Model software. The Reliability Pricing Model Benefit component of the Benefit/Cost Ratio evaluates the benefits of a proposed economic-based enhancement or expansion that will be realized in the capacity market and is expressed as:

$$\text{Reliability Pricing Benefit} = [.70] * [\text{Change in Total System Capacity Cost}] + [.30] * [\text{Change in Load Capacity Payment}]$$

The Change in Total System Capacity Cost is the difference between the sum of the megawatts that are estimated to be cleared in the Base Residual Auction under PJM's Reliability Pricing Model capacity construct times the prices that are estimated to be contained in the offers for each such cleared megawatt (times the number of days in the study year) without and with the economic-based enhancement or expansion.

The Change in Load Capacity Payment is the sum of the estimated zonal load megawatts in each PJM transmission zone times the estimated Final Zonal Capacity Prices (payments paid by load in each transmission zone) for capacity under the Reliability Pricing Model construct (times the number of days in the study year) without and with the economic-based enhancement or expansion. The Change in Load Capacity Payment will be evaluated in the same manner as the Change in Energy Load Payment. Like for the Change in Energy Load Payment, in determining the Change in Load Capacity Payment for projects the costs of which will be assigned cost responsibility on a regional basis (e.g. above 500 kV facilities), the Load Capacity Payment in each and every PJM transmission zone will be considered; for projects, the cost of which will be allocated using a flow-based or distribution factor methodology (e.g. below 500 kV facilities), only the Load Capacity Payments in the PJM



transmission zones that show a decrease will be considered in determining the Change in Load Capacity Payment.

## **E.2 Total Annual Enhancement Cost**

The annual cost of the enhancement is the revenue requirement of the enhancement. The enhancement's annual revenue requirement is an assumption that is developed by PJM and presented to the TEAC for discussion and review. As stated earlier, the benefits and costs will be considered over the same time period (for each of the first fifteen years of the life of the expansion).

## Attachment F: Determination of System Operating Limits used for planning the Bulk Electric System

This document describes the process and measures used by PJM to develop System Operating Limits (SOLs) used for the planning horizon. The method described in this attachment is applicable to all Bulk Electric System (BES) facilities.

Definitions:

A System Operating Limit (SOL) is defined as:

The value (such as MW, MVAR, Amperes, Frequency or Volts) that satisfies the most limiting of the prescribed operating criteria for a specified system configuration to ensure operation within applicable reliability criteria. System Operating Limits are based upon certain operating criteria. These include, but are not limited to:

- Facility Thermal Ratings (Applicable pre- and post-Contingency equipment or facility ratings)
- Transient Stability Ratings or Limits (Applicable pre- and post-Contingency Stability Limits)
- Voltage Stability Ratings or Limits (Applicable pre- and post-Contingency Voltage Stability)
- System Voltage Ratings or Limits (Applicable pre- and post-Contingency Voltage Limits)

PJM's Planning analyses are designed to ensure all applicable PJM, NERC, regional and Transmission Owner criteria are enforced. This is accomplished through exhaustive application of established PJM facility ratings in the on-going system power flow and short circuit analysis. PJM ensures that its exhaustive application of facility ratings are also within system dynamic limits through system dynamic testing. This dynamic testing confirms that PJM system operating limits are not more limiting than the limits established using facility ratings.

**Facility Ratings** are defined by NERC as:

The maximum or minimum voltage, current, frequency, or real or reactive power flow through a facility that does not violate the applicable equipment rating of any equipment comprising the facility.

Facility ratings determine the fundamental limits of transmission system equipment. SOLs shall not exceed the facility ratings. The facility rating is based on which ever device or component is the limiting element of the facility such as a conductor, current transformer, disconnect switch, circuit breaker, wave trap or protective relay. PJM plans its system such that no facility exceeds the limit/rating consistent with NERC Standard TPL 001 – 004. Additional information concerning SOL can be found in the Transmission Operations Manual (M-03), and Reliability Coordination Manual (M-37) located on the PJM web page at the following link:

<http://www.pjm.com/documents/manuals.aspx>

**Interconnected Reliability Operating Limits** are defined as:

An Interconnected Reliability Operating Limit (IROL) is defined as System Operating Limits that, if violated, could lead to instability, uncontrolled separation or Cascading Outages that adversely impact the reliability of the Bulk Electric System. In the planning horizon PJM analyses examine and reveal the violations of applicable criteria. This includes violations affecting PJM monitored facilities at all voltage levels as well as violations that may have widespread impacts affecting the Bulk Electric System, which may be eligible for designation as IROLs. PJM plans system upgrades for violations of applicable criteria, thus IROL designations are not typically required for the upgraded system in the planning horizon. PJM closely tracks the project status and milestones of all planned upgrades on a frequent and recurring basis. For baseline reliability upgrades, the project tracking is coordinated with the entity that has been designated the construction responsibility, typically the Transmission Owner. If the schedule for implementation for a planned upgrade does not meet in-service date required for system reliability in the planning or operating horizon, PJM will perform additional analysis to determine any alternative plans that need to be taken to ensure system reliability, including the establishment of an IROL. For additional information on IROLs for the operating horizon see the PJM Transmission Operation Manual (M03) and the PJM Reliability Coordination Manual (M37).

PJM's Planning methodology to determine IROL facilities simulates transfers across a facility or interface (combination of facilities), comparing thermal and voltage violations associated with a facility. The transfer scenarios used by PJM Planning are established through the application of PJM's deliverability criteria. Additional information on PJM's deliverability criteria is included in Attachment C of this manual. PJM classifies a facility as an IROL facility on the network if wide-area voltage violations occur at transfer levels that are near the Load Dump thermal limit.

As part of the development of the PJM Regional Transmission Expansion plan, SOLs which could result in system instability or uncontrolled cascading outages are identified and system reinforcements are developed. All BES facilities in PJM's footprint and ties to external systems are monitored for violation. In addition, certain selected 69kV and below facilities may also be monitored consistent with the procedures defined in the PJM Transmission Operation Manual (M-03).

### **SOL and IROL use in Planning**

PJM plans its system based on the most restrictive System Operating Limits (such as MW, MVar, Amperes, Frequency or Volts) of its facilities for the system configurations and contingency conditions that represent the most stringent of the applicable PJM, NERC, regional or Transmission Owner criteria over the planning horizon. The System Operating Limits used to plan the system are consistent with the limits used in Operations. Voltage limits and any exception to those limits are identified in the PJM Transmission Operation Manual (M-03).

An Interconnection Reliability Operating Limit is the value (such as MW, MVar, Amperes, Frequency or Volts) that is derived from or is a subset of the System Operating Limits, which if exceeded, could expose a widespread area of the Bulk Electric System to instability, uncontrolled separation(s) or cascading outages. PJM Reliability Coordination Manual (M37) defines PJM's methodology for determining, monitoring, and controlling IROL facilities.

Nuclear Power Plant Generator Operators are required to transmit Nuclear Plant Interface Requirement (NPIR) to transmission entities. The transmission entities are required to

include those parameters into planning and operational analysis, operate to meet those parameters, and inform the nuclear licensees when those parameters cannot be met for any reason. For details please refer to Manual M03 Section 3:

<http://www.pjm.com/~media/documents/manuals/m03.ashx>

### **PJM Planning SOL Methodology**

Consistent with the requirements of NERC Standard TPL-001, in the pre-contingency state and with all facilities in service, all facilities shall be within their facility ratings and within voltage and stability limits. In the determination of SOLs, the BES condition used shall reflect expected system conditions and shall reflect changes to system topology such as facility outages.

Following single contingencies as defined in NERC Standard TPL-002 all facilities should be within their applicable facility ratings and the system shall be transient, dynamic and voltage stable. Cascading outages or uncontrolled separation shall not occur.

Starting with all Facilities in service, the response to a single contingency as defined in NERC Reliability Standard TPL 002, may include any of the following:

Planned or controlled interruption of electric supply to radial customers or some local network customers connected to or supplied by the faulted facility. This is often referred to as consequential load loss.

System reconfiguration through manual or automatic control or protection actions.

To prepare for the next Contingency, system adjustments may be made, including changes to generation, uses of the transmission system, and changes to the transmission system topology.

Starting with all facilities in service and following any of the multiple contingencies identified in NERC Reliability Standard TPL-003 the system shall be transient, dynamic and voltage stable and all facilities shall be within their applicable facility ratings and within applicable thermal, voltage and stability limits. Cascading Outages or uncontrolled separation shall not occur. In general, stability is not a limiting constraint in the PJM RTO. Stability limits that have been identified for certain system configurations or following multiple contingencies are identified in the PJM Transmission Operation Manual (M-03). New stability limits identified in Planning are communicated to PJM Operations and included in the Transmission Operation Manual (M-03).

In determining the response to any of the multiple contingencies, identified in NERC Reliability Standard TPL-003, in addition to the actions identified above following single contingencies, the following shall be acceptable:

For all tests, as described in Attachment D-1, consequential load loss of up to 300 MW may occur.

PJM's Reliability Planning methodology for determining SOLs utilizes multiple standards and applicable planning procedures including the PJM Reliability Planning Criteria, NERC Planning Standards (TPL 001 – TPL 004), Regional Reliability Organization criteria, and individual Transmission Owner FERC filed criteria. In all cases, PJM applies the most conservative of all applicable planning criteria when identifying reliability problems. PJM tests these criteria on a regional basis including all facilities within its footprint. All BES network elements in PJM's footprint and all transmission tie lines within PJM and to external

systems are monitored for thermal, voltage and stability violations. Remediation plans are developed to mitigate the violations that exceed the established SOL limits.

PJM's develops models for specific planning horizons using the latest Eastern Reliability Assessment Group (ERAG formerly MMWG) modeling information available for the applicable planning period. A detailed model is utilized for PJM's internal system (transmission owner under PJM's footprint) while the latest ERAG model for that planning period is used for facilities outside of PJM to incorporate critical modeling details of other control areas. Additional information about PJM's base case development procedures can be found in section 2 of this manual.

PJM reliability planning criteria requires that the system be tested for all BES single contingency outages and all common mode outages. Common mode outages consist of line faults coupled with a stuck breakers that result in multiple facility outages, double circuit towerline outages and bus faults in the PJM system. PJM's planning procedures require all NERC category A, B, and C conditions be tested.

When appropriate PJM will identify and implement Special Protection Schemes. If the scheme is required for reliability purposes, operational performance, or to restore the system to a reliable state following a significant transmission facility event, operation of the scheme will be tested in the on-going planning analysis. See the Transmission Operations Manual (M-03) (<http://www.pjm.com/documents/~media/documents/manuals/m03.ashx>) for additional information concerning special protection schemes.

The PJM planning process includes a series of detailed analyses to ensure reliability under the most stringent of applicable NERC, PJM or local criteria. Through this process, violations of system operating limits are identified. System reinforcements required to mitigate the violations are developed and included in the Regional Transmission Expansion Plan for implementation. As a result PJM's application of its System Operating Limits for the planning horizon ensures system operation within Interconnection Reliability Operating Limits.

PJM Planning will communicate to PJM Operations any potential IROL facilities resulting from PJM deliverability criteria analysis. PJM Planning and Operations work to develop new IROL Reactive Interfaces and associated operating procedures as required.

## Attachment G: PJM Stability, Short Circuit and Special RTEP Practices and Procedures

### G.1 Stability

PJM Planning conducts stability studies to ensure that the planned system can withstand NERC criteria disturbances and maintain stable operation throughout the PJM planning horizon.

NERC criteria disturbances are those required by the NERC planning criteria applicable to system normal, single element outage and common-mode multiple element outage conditions. These conditions are specified in the NERC approved Transmission Planning (TPL) Reliability Standards that can be found on the NERC website ([www.NERC.com](http://www.NERC.com)). Because these standards change from time to time they are included here by reference. In addition, PJM's analyses also satisfy the Transmission Owner specific stability practices and procedures as may be applicable when these are more demanding tests than the standard NERC criteria tests applied by PJM. All Transmission Owner specific information and criteria that exceed *standard testing of NERC criteria* and are applicable to PJM reliability based RTEP stability analyses are included or referenced in the Appendix to this Attachment. Transmission Owner stability criteria filed as FERC Form No. 715 and posted on PJM's website and not included in the Appendix may be used to support Transmission Owner funded upgrades. The currently approved version of this Appendix at the commencement of the annual RTEP process will be the basis for that baseline RTEP and related generator queue assessments. PJM's stability analyses verify satisfactory projected system performance over the range of anticipated load levels and identify any need for upgrades, operating guides, or special protection systems that may be indicated based on stability or short circuit testing as a primary driver. In general, the most appropriate remedy to NERC criteria violations is a system upgrade. In circumstances involving criteria that go beyond PJM's standard testing of NERC criteria, operating guides or special protection system remedies may also be considered as discussed further in this Attachment and its Appendix. New Special Protection Systems, however are generally avoided and, if considered, require case-by-case review and justification. Also certain specific areas of PJM have been identified through PJM or Transmission Owner analysis as stability limited areas of the system. In such areas of the system, stability operating guides may apply. For related information see PJM Manual 03 at <http://www.pjm.com/documents/manuals.aspx>.

System conditions most critical for stability analysis on the PJM system are generally characterized by light load. Peak load analysis is added for stability reviews that involve new connections of wind turbines and performance of low voltage ride through testing. In exceptional cases, PJM may add heavy load testing for other types of units when PJM determines that heavy load may be the critical load level for system stability for the limitation under review.

PJM's stability analyses ensure the dual objectives of stability of new interconnection projects and system-wide stability. PJM, each year conducts dozens of interconnection queue project stability studies. These analyses ensure newly-connecting projects and nearby changes to the system configuration maintain the stability of the project and the system. Study of these projects located throughout PJM provides a thorough, ongoing review of PJM both at the project level and system-wide. In addition, each year, PJM conducts a re-study of one third of existing PJM generation stations. This results in a three-year cycle of on-going re-study of the entire PJM system. PJM also performs additional system-wide stability analyses during the annual RTEP review. In addition, as may be required from time to time, PJM conducts stability analyses to

evaluate the dynamic performance of actual or possible major future system developments. For example a proposed new backbone transmission project or prolonged unexpected backbone transmission outage in a stability sensitive area would be cause for a specifically targeted system study. Another cause could be the need to evaluate system performance resulting from major developments affecting power and energy policy.

## **G.2 Dynamics Procedures**

This section provides a high level review of the process of setting up and performing dynamics analyses.

### **G.2.1 Dynamics Reference Cases**

Reference power flow cases for stability analysis are created in a similar manner to that of the power flow reference cases. Additional information, however, is necessary for stability studies to simulate the combined dynamic responses of various power system components. Included in this additional information are dynamics models for generators, excitation systems, power system stabilizers, governors, loads and various other equipments. The required dynamic and other modeling information that must be supplied by generators interconnected to the PJM system is detailed in Manual 14A. A dynamic simulation links the system model or power flow information with the dynamic data or models to determine if the system and generators will remain stable for steady-state and various disturbances. The current RTEP summer peak case is used as a starting point to create new dynamics cases (light load and peak load.) For example the RTEP analysis is performed for the current year plus five (available early in each calendar year and updated for the five-year-out RTEP analyses in early fall of each calendar year). The stability case setup is for the same study year using the updated RTEP case. This updated RTEP power flow case and the associated stability case become the baseline cases for the impact study analyses (that begin in the fall of each year) that begin with the first interconnection queue of each calendar year and continue through each of the 3 subsequent annual queues.

### **G.2.2 Dynamics Analysis**

The two dynamics cases Originate from the RTEP Power Flow Case that is created for the annual RTEP Plan analyses. The annual RTEP cycle is depicted in Manual 14B, Exhibit 1. The earliest availability for this annual RTEP reference power flow case is for the impact studies associated with the interconnection request queue that closes on January 31. For subsequent project queues that close later in the year, this reference RTEP case is updated to the most current data. The reference power flow case is reviewed and modified as necessary to correspond to the dynamics database (which includes external world dynamics data from the NERC System Dynamics Data Working Group as well as PJM data.) In addition, the case is modified to include generator step-up transformers and explicit modeling of generator station service power use along with gross generator rating. Also, because of the demands of dynamics analyses, power flow static load representations are replaced with their dynamic load model representations. PJM currently represents loads as 100% constant current real power and 100% constant impedance reactive power. In light load representations, pumped storage resources are in pumping mode.

This process is followed to develop stability setups for analysis of all PJM interconnection requests. In addition PJM's system stability analyses will use the most current available setup from this continuous development process.

### Testing

After the dynamics model setup, an unperturbed dynamic simulation is run for 20 seconds. After case verification, the final, initialized set of power flows and the associated snap-shots, along with the associated dynamic run files are available to Interconnection Customers and others who have a legitimate need for the information, subject to applicable Confidentiality and Critical Energy Infrastructure Information processes (see PJM Operating Agreement §18.17 and <http://www.pjm.com/documents/ferc-manuals/ceii.aspx>).

### Dispatch

The assumptions used for generation dispatch can be critical to the results. It is generally accepted that units operating at their highest possible power output and generating as little reactive power as necessary to maintain voltages are likely to be less stable. Normally, the units in the vicinity of the project under study will be turned on to their maximum real power output with unity power factor at the high side of the GSU's, or units' VAR output will be adjusted to hold scheduled voltages, depending on specific Transmission Owner criteria. Wind turbines are tested at light load for stability and peak load for low voltage ride through at 100% of their maximum energy value. In addition, stability test scenarios necessitated by any applicable Transmission Owner operating guides will also factor into each analysis.

### Simulations to determine required upgrades (also see the Appendix to this Attachment)

#### Fault Criteria:

- a. Fault Types: For interconnection and system stability analyses, three phase faults, single line to ground faults with stuck breaker and single line to ground faults with the communications failure cleared within zone 2 time will be examined. Each analysis will include a determination of the most critical faults to apply.
- b. Clearing Times: Dynamic simulation issues are identified using estimates of actual (nominal) clearing times, including relay trip times, breaker interrupting time, fault extinguishing time, intentional delay time, and a margin for error.
- c. Reclosing: Only high speed reclosing is modeled if present.
- d. Fault locations: For interconnection analysis, criteria faults at power flow busses including one bus removed from the interconnection point will be examined. When clusters of generating busses are studied, the most critical faults one bus removed from new generators in the cluster will be examined. In addition, other fault locations judged critical to cluster response will be added to the scope. For system analyses, the scope will determine the most critical locations to apply criteria faults.
- e. Maintenance outages: Interconnection analyses of planned line maintenance outage conditions prior to fault application are system

conditions that can be anticipated and that are generally of limited duration. The least cost remedy to issues during such system conditions is to require generation to curtail output. Such analyses are, therefore, of primary interest in the operating horizon and are not generally considered to determine upgrade facilities required prior to interconnection. Nevertheless, prior to commercial operation, or prior to completion of the facilities study at the request of the Interconnection Customer, Planning will screen critical faults for issues during line maintenance. The results of the line maintenance study will be conveyed to PJM Operations, the Interconnection Customer, and affected Transmission Owners.

PJM addresses Power System Stabilizer (PSS) outages in a similar fashion. If there are existing PSS installations nearby a new interconnection or if PSS is required on the new interconnection, critical faults for the outage of these devices will be studied prior to commercial operation and the results will be conveyed to PJM Operations, the Interconnection Customer, and affected Transmission Owners.

#### Margins:

The margins applied by PJM are intended to be applied in impact study stability analysis that uses a project's final stability study data as further discussed below. As such, these margins account primarily for uncertainty in actual clearing times, and the final data represents the "as built" performance. With the machine modeled at net unity power factor at the high-side of the GSU (or unity power factor at the generator terminals for wind turbine installations), transient stability must be maintained for tested faults when the following margins are included:

- a. Add 0.25 cycles to the nominal primary clearing time for 3 phase, normally cleared faults.
- b. Add 0.25 cycles to the nominal primary clearing time for single-line-to-ground faults, plus an additional 0.5 cycles added to the nominal backup clearing time for stuck breaker (.75 cycle total clearing time margin).
- c. Add 0.25 cycles to the nominal primary clearing time for single-line-to-ground faults, plus an additional 1.25 cycles to the nominal Zone 2 clearing time for failure of primary relaying (1.5 cycle total clearing time margin).

#### Monitoring requirements:

Rotor angle, Real power output, EFD, speed and terminal voltage of units under study are monitored. Bus Voltages in the same area are also monitored.

#### Acceptable Voltage Drop:

Following the disturbance, the voltages of the monitored buses maintain voltages within  $\pm 5\%$  of the precontingency voltages

#### Acceptable Damping:

Following the disturbance, the oscillations of the monitored parameters display positive damping. The positive damping is determined with a damping coefficient calculation algorithm. This characterizes the degree of positive (damped) or negative (undamped) damping based on the damping trend, over the duration of the stability run, of the envelope of machine angle oscillation peaks. This trend can be observed

by drawing an envelope connecting each succeeding peak or valley of the oscillation of the monitored element. An acceptable oscillation envelope will demonstrate a positive decay within the appropriate test period (normally 10 to 15 seconds). A sustained oscillatory system response, even if slightly damped, will cause the system to be in a vulnerable state and exposed to adverse impacts for subsequent changes to the system over some prolonged time. To limit this system exposure PJM uses a 3% damping margin. Such positive damping demonstrates an acceptable response by the system, and no further analysis is required. Failure to meet the damping standard will require application of some combination of power system stabilizers, excitation system upgrade and tuning, and system upgrade.

### **G.3 System Impact Study and Initial Study Stability Procedures**

Generating unit stability analysis is performed by PJM as a part of the System Impact Study for proposed generation interconnection to the PJM system. PJM also conducts annual system stability analysis of the PJM system in compliance with applicable NERC transmission planning criteria. PJM's standards for stability analyses satisfy NERC criteria and are the generally applicable criteria for all PJM stability analyses. In addition, Transmission Owner stability criteria may apply. Certain specific areas of PJM have been identified by PJM or Transmission Owner analysis as stability limited areas of the system. In such areas of the system, stability operating guides may apply. See PJM Manual 03 at <http://www.pjm.com/documents/manuals.aspx> for more information on PJM stability operating guides.

#### **G.3.1 Stability Data Requirements**

a. Submission of Project Stability Study Data

Stability study data is included in the data required for the series of studies generally required for a System Impact Study. A System Impact Study typically includes a short circuit study, power flow study and stability study. As required by the PJM Tariff, and detailed in PJM Manual 14A, all data for the System Impact Study, including stability analysis data, must be submitted by the Interconnection Customer as part of a completed System Impact Study Agreement. System Impact Study Agreements are not complete until the required agreement is fully executed and all associated data for the complete series of studies is received. Upon PJM's acceptance of a completed System Impact Study Agreement, all associated data becomes the Interconnection Customer's final data for the System Impact Study and any subsequently necessary Facilities Study.

b. Final Stability Study Data

Prior to beginning any of the studies generally required for a System Impact Study, PJM will accommodate modifications to submitted data unless, in PJM's judgment, such modification would adversely impact subsequently queued projects. It is the Interconnection Customer's responsibility to establish and maintain communication with the assigned PJM Project Manager to determine the latest date that specific data changes can be accommodated. Interconnection Customers are encouraged to work closely with their Project Managers to determine if

any anticipated project changes can be accommodated without adversely affecting subsequent projects. After acceptance of the System Impact Study Agreement, PJM is under no obligation to accept any changes in data and may proceed through the System Impact Study, Facilities Study and the Interconnection Service Agreement processes on the basis of the final data. This final data is considered consistent with the “as built” representation of the system. As such, it should represent the actual equipment that will be installed and commissioning settings that can be achieved.

c. Changes to Stability Data After Commencement of Stability Study

This section addresses project changes that affect the stability study and often the short circuit study. Such changes typically involve the electrical, configuration and physical parameters of the generator and associated electrical equipment between the connection to the networked power system and the generator. While some configuration changes could necessitate power flow re-study, the changes that are discussed here only cause stability and possibly short circuit re-study.

After the start of the stability study PJM will complete the stability study, issue the System Impact Study report, complete any necessary Facilities Study and issue the Interconnection Service Agreement. After the start of the stability study, changes to electrical parameters that will require stability re-study, will be accommodated by PJM as resources are available and in a manner that does not negatively impact later queued projects. In addition, certain parameter changes may also require new short circuit studies. Necessary re-study caused by parameter changes may be performed by contractors. The re-study will be performed on the system model that includes all project studies completed at the time of the re-study. The scope of the re-study will determine all necessary incremental system facilities necessitated by the parameter changes.

d. Cost of Incremental Facilities Caused by Re-study

The Interconnection Customer that makes the parameter changes that cause re-study will be responsible for the costs of re-study and the cost of the incremental facilities that are specified by the re-study, including facilities that are revealed by the short circuit re-study.

### **G.3.2 System Impact Study Stability Scope and Process**

These procedures apply to stability studies required as part of System Impact or Initial Studies. These stability studies determine the project’s cost responsibility for upgrades due to interconnection stability issues. These upgrade responsibilities become part of a project’s Interconnection Service Agreement (ISA.)

Stability study start dates, generally, are at least six months after the close of a queue. This allows time to complete feasibility studies and the power flow and short circuit phases of the impact study. This section outlines the process of coordination and execution of the stability study among the representatives of PJM, the Interconnection Customers and Transmission Owners.

1. PJM will develop a study scope at the beginning of each project stability analysis. This scope will include but not be limited to the following items:
  - 1.1. The MW Size of the project. Developers may reduce the project maximum output, based on tariff terms, from the feasibility request. Stability will study projects at their maximum outputs regardless of the project's value for capacity markets.
  - 1.2. The electrical Point of Interconnection (POI) of the project. For projects that tap an existing transmission line, the feasibility power flow generally assumes a line POI is at the line midpoint. Stability analysis will require the actual location information to determine the tap point.
  - 1.3. A detailed fault list testing all applicable NERC and Transmission Owner criteria faults. Fault specification will include fault:
    - 1.3.1. location
    - 1.3.2. phase involvement
    - 1.3.3. impedance
    - 1.3.4. actual timing for clearing and reclosing
    - 1.3.5. explicit timing or other margins to be added
    - 1.3.6. justification of any procedures that exceed PJM standard methods
  - 1.4. Dispatch in the vicinity of the study location.
  - 1.5. Selection of the appropriate base case, light load or peak load, for study of the interconnection request.
2. Study scope will be supplied to the affected Transmission Owner. Affected parties have one week to provide input to the study scope after which time PJM will issue the final scope and a date that the study will begin. All special study conditions, scenarios or simulations, if any, required by guides or sensitive areas and accurate clearing times must be included in this final scope. The study will progress to completion based on the final scope document.
  - 2.1. The study scope for interconnection studies will consider *standard NERC criteria* faults and Transmission Owner criteria faults, as a general rule, including the POI bus and one bus away from that bus. In other words if a new POI is cut-in at the midpoint of an existing line, faults will be examined at the POI, and up to and including faults at the adjacent existing system substations and lines. If a project interconnects to an existing system bus location, then faults at that location and including adjacent substations and lines will be examined. When new interconnection requests are considered, in PJM's judgment, in a cluster study, they will consider intervening bus location faults (further than one bus from any new interconnection) at PJM's discretion when the electrical configuration indicates that the added locations could pose a more severe test and that a contributing cause of the stability concern is the new interconnection. In a similar fashion, PJM may use its judgment in any stability analysis to expand the fault locations outside the general "one bus removed" criteria when system electrical configurations dictate and the interconnecting project poses the concern.
  - 2.2. The stability scope for interconnections in areas affected by established operating guides or Special Protection Systems (SPS) (for example see Manual 03) may include scenarios designed to test the proper operation of the existing guides or SPS. In such

cases, the scope may be augmented to examine and specify modified procedures or facilities that ensure the integrity of the system operation.

3. After completion of the study scope, PJM will transmit results and supporting information to the Transmission Owner. A review conference call between the Transmission Owner and PJM will be scheduled within a week of providing the results.
4. The transmission Owner will provide an estimated date for completion of its determination of system remedies for any issues identified in the stability results. Such remedies will include system impact cost estimates and the earliest feasible date to complete system modifications that accommodate the new interconnection.
5. Upon completion of the Transmission Owner review and estimates PJM will issue the final impact study report to the project developer.
6. In situations when the required system modifications or upgrades cannot be accomplished by the projected in-service date of the project, PJM will develop a scope and schedule to determine interim solutions and dates along with provided interim capability.

## **G.4 System Stability Studies**

In addition to the system impact stability analyses of new generating interconnections, the three year cycle testing of all existing generating units interconnected to the PJM system, and certain “ad hoc” stability testing required by special circumstances that occur from time to time, PJM also conducts system stability testing of its most critical stressed system conditions during the annual Regional Transmission Expansion Plan study cycle. The RTEP stability testing examines and ensures system performance within criteria for heavy system transfer conditions. Power flow criteria are ensured on a local and system-wide basis for heavy transfers during the application of PJM’s load deliverability testing (see Manual 14B Attachment C.) These test scenarios examine emergency conditions involving extreme generating outages and loads coupled with single transmission element outages. Such circumstances are critical when the system is stressed at heavy load, rather than light load.

Based on the results of each annual RTEP cycle and previously completed stability analyses, PJM determines the load delivery limits for the case that represents the most critical conditions for PJM system stability testing. The transfers into the selected Region emanate from external PJM and non-PJM generation. Imports from external areas are based on historical levels for heavy load. An example of the type of PJM scenario that could represent the critical study condition may have local load of 65,000 MW with a transfer into the area caused by the simultaneous outage about 10,000 MW of internal area generation. This may cause a thermal limit to transfers well in excess of 6000 MW.

The transmission outage that sets the limit for transfers during the Mid-Atlantic load delivery testing is modeled for stability to ensure that the region is not stability limited. PJM also determines several more critical three-phase and single-line-to-ground fault tests to apply from a stability perspective to ensure robust, stable and adequately damped system performance. Fault testing for system stability includes the most critical Bulk Electric System lines.

## G.4.1 NERC Category C3 “N-1-1” System Stability Studies

### INTRODUCTION

An N-1-1 contingency pair is defined as a single line to ground (SLG) or 3-phase fault with normal clearing, manual system adjustments, followed by another SLG or 3-phase fault with normal clearing. In the NERC TPL standard, N-1-1 contingencies belong to Category C3. Manual adjustments after first (N-1) contingency are allowed to relieve any thermal or voltage violations for applicable ratings and/or to prepare for second (N-1-1) contingency. N-1-1 stability analysis is defined as a stability analysis for given N-1-1 contingency scenarios. For a given N-1-1 contingency scenario, the first (N-1) contingency is applied to a pre-disturbance base case. If the system is stable, a new operating point is computed and manual adjustments are made if necessary, and then stability is monitored following second (N-1-1) single contingency. Because of the assumed long time delay (from a stability point of view) between two single contingencies, the N-1-1 stability analysis is similar to maintenance outage study for operational guidelines.

### DISPATCH

Initial base case creation for N-1-1 stability analysis follows the procedure in Attachment G, section 2.2. When an N-1 base case is created, care needs to be taken before an N-1-1 contingency is applied. First, all thermal or voltage violations in the N-1 base case should be resolved through system adjustment. Second, if available, any existing operating guidelines for the N-1 outage condition needs to be applied to the N-1 base case.

### N-1-1 STABILITY ANALYSIS PROCEDURE

Considering the number of generating machines in the PJM system and the number of possible N-1-1 contingency pairs, it is very challenging to cover all of them within a reasonable lead time. In general testing all N-1-1 contingency pairs for stability is impractical and not necessary due to the fact that most contingency pairs are electrically far away from a study plant or independent from each other. It is essential to screen out critical contingency pairs which have potential stability problems without missing any potentially unstable N-1-1 contingency pairs.

Overall procedure of N-1-1 stability analysis for generating units in PJM area is as follows:

1. Selection of plants for the N-1-1 stability study
  - A. The scope of annually studied plants will include the same plants included in the scope of the baseline stability study that year. Similar to the baseline stability study, one third of generators in PJM will be considered for the N-1-1 stability analysis each year resulting in each.
  - B. If PJM Transmission Planning determines that the scope cannot be completed within a reasonable lead time, PJM Transmission Planning will prioritize the plants in the scope of the study and higher priority plants will be studied first.
  - C. With the request of PJM Operation or Transmission Owners due to special operation need, the study for specific plants would be performed.
2. Selection of N-1-1 contingency pairs for each plant.
  - A. N-1-1 contingency pairs within one bus from the high tension bus of the study plant are tested. If the number of branches connected to the high tension bus is less than three, the boundary of N-1-1 contingency pairs is extended to two buses away.
3. Conduct N-1-1 stability study

- A. Assume N-1 stability results are available from the baseline stability analysis.
- B. If an N-1 contingency is transient unstable, the N-1 stability issue must be resolved first. For each N-1-1 contingency pair, create an N-1 base case by solving a power flow after the N-1 contingency is applied to the N-0 base case. If there are any thermal or voltage violations, resolve them through system adjustments. Also if available, apply existing operating guidelines for the N-1 outage condition to the N-1 base case.
- C. Conduct comprehensive time-domain simulation for the N-1-1 contingency and assess stability.
  - I. Following standard PJM stability criteria, both transient stability and damping will be monitored
- D. Consider SPSs or other specific operating guidelines.

#### STUDY PLANTS SELECTION

The factors taken into account in prioritizing plants include the size of a plant, N-1 baseline stability study results, plant fuel type, and the unavailability rate of neighboring branches of the study plant. The following plants are given the highest priority for the N-1-1 stability study.

- Nuclear plants take the highest priority and will be studied if they are in the scope of the annual baseline stability study
- Plants with the maximum output of 1000 MW or above.
- Plants having weak stability performance in baseline stability study.
- Plants that experienced operational stability issues in real-time.
- Plants having neighboring branches with high unavailability rate due to planned and/or unplanned outages.

#### N-1-1 CONTINGENCY SELECTION

Due to the number of combinations of N-1-1 contingencies, only single contingencies that are 1-bus away from the high-tension buses of the study plant are considered. In the example below, five single transmission line outages are considered in the N-1-1 stability study as shown in Fig. 1.

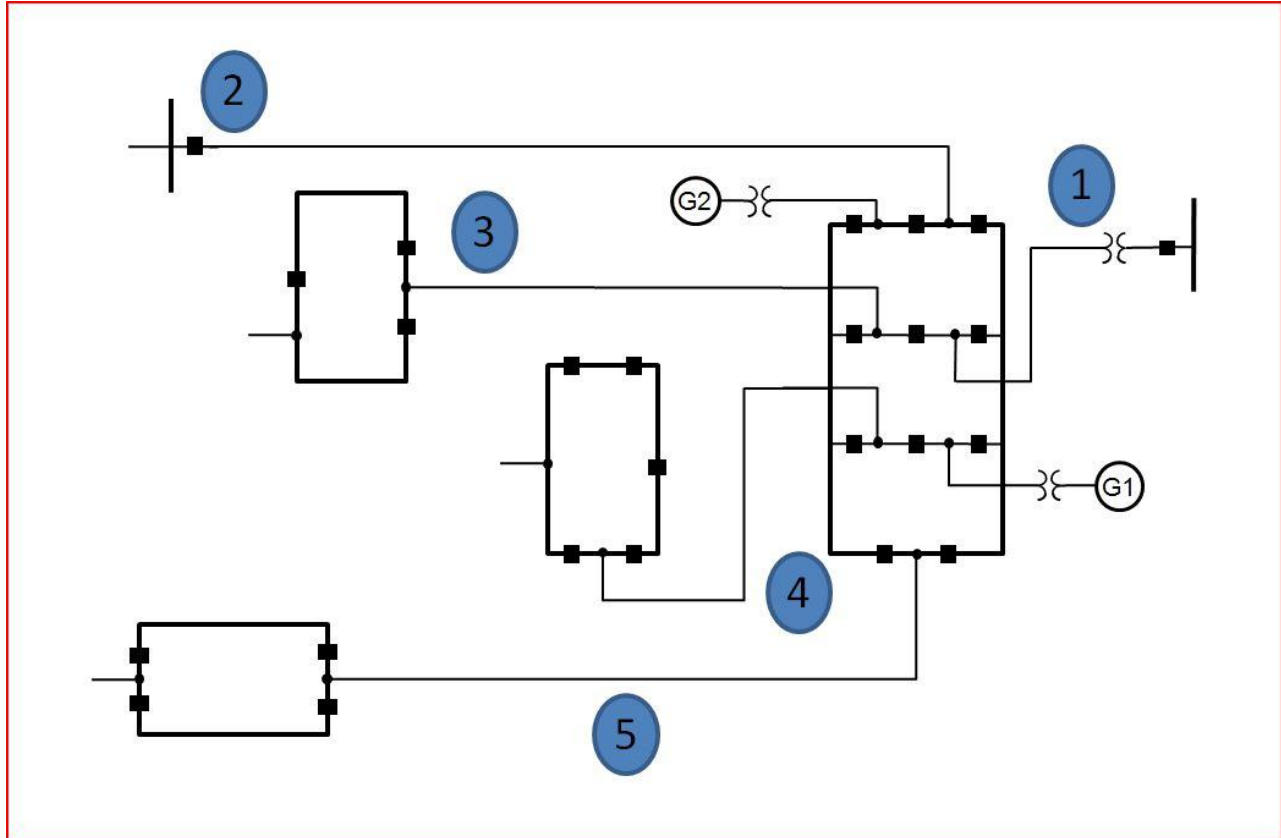

Figure 1 – Example of Five transmission lines for the N-1-1 stability study of a generic location.

It is necessary to analyze total 25 (5 N-1 and 20 N-1-1 contingency scenarios) contingency scenarios for the example plant in Figure 1. It is also noted that 3-phase fault cleared by primary relays is considered for all single contingencies. Fault clearing times are in form of possible ranges for different areas, kV and fault clearance options and the upper values of the respective ranges are used. Existing special protection schemes are, if available, incorporated in the N-1-1 contingency scenarios.

#### MITIGATION

Any violation of PJM or other applicable stability criteria as described in this Attachment will be addressed and documented as part of the annual RTEP process.

### G.5 Impact Study Procedures Applicable to Wind Turbine Analyses

PJM follows a process of procedures and studies when handling requests to interconnect to the transmission system. These procedures are outlined in PJM Manuals and agreements, particularly PJM's Manuals 14A and 14B and the PJM Open Access Transmission tariff (OATT.) In recognition of some of the unique characteristics and challenges posed by wind projects, however, the PJM OATT procedures include certain special provisions applicable to wind farm interconnection requests. Interconnection Customers should familiarize themselves with all applicable PJM procedures and requirements, in consultation with their assigned PJM project manager. Some provisions of particular interest to wind interconnection requests can be found in OATT PART IV, Subpart A, PART VI, Subpart A, and OATT Attachment O Schedule H.

### **G.5.1 Wind Project Final Impact Study Data**

Upon entering the interconnection queue, wind generators may submit approximate data for the feasibility study that represents the wind farm as a single equivalent unit. Prior to commencement of the wind farm impact study the approximate data must be replaced with detailed design data including the detailed electrical layout of the wind farm. This data is required for wind farm projects, by tariff provisions, no later than six months after the filing of the interconnection request. As described in the general discussion of System Impact and Initial Study procedures, final impact study data is generally required at the beginning of the system impact study process which often will happen to be about six months after the close of the queue. In the case of wind projects, tariff requirements ensure that the data may be supplied up to six months from the initiation of the queue request. In practice the wind farm developer, as well as all project developers, should maintain good communications with the assigned project manager to determine when PJM is scheduled to begin a specific project's stability analysis.

### **G.5.2 Wind Project LVRT Requirements**

In addition to all facets of the standard stability study scope previously discussed, wind generators will be studied during their impact study stability analysis for compliance with the Low Voltage Ride Through Criteria (LVRT.) The LVRT criteria tests the ability to the wind farm generator to maintain operation and interconnection with the system during events that cause extremely low voltage transients as measured at the high side of the transformer that steps up the Wind Farm's voltage to the transmission system (high side of the wind farm GSU.) Peak load conditions are the most stressful for maintaining system voltage so this analysis will be conducted on a peak load power flow model (in contrast to the standard stability analysis that is conducted on an off-peak model.) Based on the results of the standard stability analysis, PJM will determine the most critical three phase faults with normal clearing and phase to ground faults with delayed clearing. The wind generator will be required to maintain its power output to the system following three phase faults cleared in up through 9 cycles (9 cycles includes any applicable margins) and that produce a voltage as low as zero at the high side of the GSU. Actual clearing times plus applicable margins will be used, which may be less than 9 cycles and high side GSU voltages may be somewhat greater than zero. Also the wind farm must maintain output to the system following the most critical phase to ground faults with delayed clearing, using actual clearing times. Applicable clearing time margins will apply to the LVRT test.

### **G.5.3 Wind Project Reactive Power Modeling**

Stability tests will be conducted on a system model with the GSU modeled and zero generator reactive power output (unity power factor.) When power flow analysis does not model the generator step up transformer, the zero generator reactive power output is applied at the collector bus. This base case and the stability analysis will establish power factor or reactive power delivery requirements only if impact study analysis is conducted that demonstrates that the safety or reliability of the system is impacted by the lack of the requirement. System transient, oscillatory, or voltage instability during any phase of the impact study is evidence of system safety or reliability impact. For such results, the least cost remedy that considers system protection, transmission upgrades, or reactive requirements will be determined and specified.

In the event that the transient or voltage instability only affects the wind project (for example when long radial interconnection facilities cause the inability of the wind facility to remain stably interconnected), the wind project will be notified and be requested to provide project design remedies. PJM's analysis of possible remedies will be limited to specifying the size of dynamic

reactive device or increased transmission interconnection capacity if such a remedies are sufficient.

## **G.6 Stability Analyses of Stability Sensitive Local Areas in PJM**

The PJM system generally operates to limits determined by thermal and reactive criteria. In some specific instances local areas of PJM or individual plants operate to stability limitations. The PJM transmission system conditions and procedures due to localized thermal, reactive and stability considerations are outlined in PJM Manual 03.

The PJM Transmission Owners are often owners of the facilities that are subject to these procedures and carry out PJM's operating instructions ensuring safe and reliable operation consistent with these guidelines and procedures. PJM, therefore, closely coordinates review of the stability guides and procedures with the Transmission Owners and, when appropriate, Transmission Owners may conduct analysis, subject to PJM's review.

Stability guides applicable to specific plants are reviewed as part of PJM's three year cycle of generator stability analysis that ensures continued compliance with NERC criteria. Local stability guides and procedures are reviewed as necessary when interconnections or transmission changes cause the need for review. Each review is specific to the area or plants operating procedures and guides and confirms or develops modifications to the guide and system upgrades, as appropriate, to maintain reliable operation within applicable criteria.

## **G.7 Short Circuit**

PJM performs short circuit analysis as part of the annual Regional Transmission Expansion Plan (RTEP) baseline assessment. This analysis includes a study of the entire PJM system based on its current configuration and equipment. In addition, PJM also performs the analysis on the planned system configuration using a 5-year out case. The generation and merchant transmission interconnection process (see Manual 14A) also includes short circuit analysis for each requested new interconnection project. The addition of new sources drives most breaker replacements. PJM Planning conducts short circuit analysis to ensure the high-voltage circuit breakers on the transmission system are sufficiently rated to safely interrupt fault currents. These short circuit studies are also referred to as breaker interrupting studies. Since new sources only become committed with relative assurance a few years before scheduled commercial operation and since breaker replacement lead times are only a few years, these analysis are only conducted within the 5-year planning horizon.

The short circuit analysis is performed in accordance with the following industry standards:

- ANSI/IEEE 551-2006 "IEEE Recommended Practice for Calculating Short-Circuit Currents in Industrial and Commercial Power Systems"
- ANSI/IEEE C37.04-1999 "IEEE Standard Rating Structure for AC High-Voltage Circuit Breakers"
- ANSI/IEEE C37.010-1999 "IEEE Application Guide for AC High-Voltage Circuit Breakers Rated on a Symmetrical Current Basis"
- ANSI/IEEE C37.5-1979 "IEEE Guide for Calculation of Fault Currents for Applications of AC High-Voltage Circuit Breakers Rated on a Total Current Basis"

The system condition most critical for short circuit analysis on the PJM system is all available generation in-service. This condition is modeled in short circuit reference cases that are specially configured for short circuit analysis. The PJM Transmission Planning Department maintains the following short circuit base case representations and associated data:

- 1 year planning representation consisting of the current system plus all facilities planned to be in-service within the next year.
- Current year plus 5 planning representation using the 1 year planning representation as the base model and including all system upgrades, generation projects, and merchant transmission projects planned to be in-service from years 1 through 5. This 5 year planning representation is consistent with the PJM RTEP 5 year load flow base case.
- Data file containing current circuit breaker interrupting ratings and other relevant circuit breaker nameplate data for all BES circuit breakers.

The short circuit base cases are maintained using Aspen One Liner and short circuit analysis is performed using the Aspen Breaker Rating Module. The PJM short circuit 1 year planning representation is developed annually with the assistance of the designated transmission owner short circuit contacts and maintained by the PJM Transmission Planning Department.

## G.8 Nuclear Plant Specific Impact Study Procedures

Stability analysis of nuclear facilities is conducted during PJM's three-year cycle of stability review of all existing generating units. Also, interconnections or transmission modifications in the vicinity of existing generating stations, including nuclear stations, may necessitate additional reviews. PJM conducts these reviews consistent with the NERC criteria and certain added criteria specified by the Transmission Owner or plant operator or owner. PJM stability studies take into account coordination with any applicable Special Protection Schemes. Results of PJM Planning analyses can be found under the "planning" tab material and "committees & groups" tab material on PJM.com particularly:

<http://www.pjm.com/planning/planning-criteria.aspx>

<http://www.pjm.com/planning/rtep-development.aspx>

<http://www.pjm.com/planning/generation-interconnection.aspx>

<http://www.pjm.com/committees-and-groups/committees/teac.aspx>

PJM will notify PJM System Operations and the affected Transmission Owner in the event that PJM's planning analyses indicate planning study results that violate PJM planning criteria or nuclear specific planning criteria. In addition, results of PJM Impact Studies affecting nuclear facilities are communicated to the affected Nuclear owner and operator.

PJM applies some nuclear plant study procedures that exceed *standard NERC criteria* to be consistent with certain regulatory and safety requirements specific to these facilities. Material contained in the Appendix to this Attachment G provides Nuclear Plant Interface Requirements (NPIR) regarding the nuclear specific testing procedures applied by PJM and Transmission Owner Planning.

## G.9 Appendix to Manual 14B Attachment G

This appendix contains Transmission Owner specific criteria applicable to RTEP stability study analyses that may go beyond the NERC system stability performance tests routinely applied by PJM. PJM normal stability testing enforces the NERC criteria that are based on single contingencies and common-mode multiple contingencies. PJM does not permit planned load loss or interruption of firm transmission service for these events, even when such service curtailment may be permitted by the NERC standards. These contingencies are also referred to in this Attachment and Appendix as the “standard” NERC criteria and include the following events:

- System normal,
- Single phase and/or three phase fault (N-1),
- Single phase fault stuck breaker (N-2),
- Three phase fault tower (N-2), and
- Single Phase fault and communication failure (N-2).

More stringent NERC criteria that involve multi phase faults, non-common mode multiple contingencies, and higher order contingencies (also referred to as “beyond” *standard NERC criteria*) do not routinely form the basis for required PJM RTEP upgrades. Some Transmission Owner criteria, however, as detailed in this Appendix, go beyond the *standard PJM stability screening criteria* and do require remedies. These procedures, as applicable, are applied during PJM RTEP (including interconnection related) stability analyses in addition to PJM thorough testing of *standard NERC criteria* tests and system performance is verified to be stable and within criteria. The Transmission Owner specific criteria are limited to interconnections with the transmission facilities of the respective Transmission Owners.

All PJM testing applies the clearing margins and damping criteria discussed in Attachment G and more stringent criteria when the specific Transmission Owner criteria exceed these standard margins. In all cases PJM applies the criteria in a comparable and not unduly discriminatory fashion to new interconnection projects and existing generators. Violations based on *standard NERC criteria* and standard margins must be remedied by upgrade modifications to the system. Operating curtailments will generally be an available remedy for issues found for line maintenance outage tests.

### G.9.1 Testing of Transmission Owner Criteria

For interconnection queue studies that pass the *standard NERC* and PJM criteria but produce localized violations based on criteria that are beyond the *standard NERC criteria* and/or margins that exceed standard PJM margins, PJM, in consultation with the affected Transmission Owners, will determine lower cost remedies. For these Transmission Owner tests, planned load loss or interruption of firm transmission service is not allowed when lower cost remedies are available. An available lower cost remedy will be required to address such violations. For example, lower cost remedies that may be considered include:

- Relaying modifications
- Sectionalizing schemes
- breaker upgrades

- Independent pole tripping
- High speed breaker failure schemes
- High speed reclosing
- Fast closing of steam intercept valves
- Braking resistors.

If the search for lower cost upgrades produces none, or in the case of wide-spread system violations such as may be encountered during RTEP baseline stability analysis, then PJM, in consultation with the affected Transmission Owners, will make a more detailed assessment of the violation(s) including factors such as the extent of violations, the events' likelihood, system impact and cost to remedy. Based on the gathered information, PJM will specify a remedy including possible consideration of operating guides, special protection systems, and more extensive high voltage upgrade options.

### **G.9.2 Nuclear Station Testing**

With regard to nuclear station related planning stability analysis, in addition to the *standard NERC criteria* and specific Transmission Owner criteria testing, PJM reviews and enforces criteria testing that can be found under the Planning section of the Nuclear Plant Interface Requirement (NPIR) documents. In some cases the Transmission Owner also performs special nuclear unit stability testing as described in PJM Manual 39 and the NPIR. Together, the analyses that may be performed by the Transmission Owner and PJM's testing incorporate the voltage and stability requirements of the station. PJM ensures Transmission System performance to the specified criteria that enables the station equipment and systems to perform as designed. Nuclear voltage criteria at the Transmission System level, including any voltage drop criteria, are enforced on a system normal and post-contingency basis as described in the NPIR planning requirements. Observed criteria violations during planning assessments affecting nuclear stations will be evaluated jointly by PJM Planning and PJM Operations consistent with procedures outlined in PJM Manual 39. Appropriate remedies, consistent with this Attachment and the PJM Manuals and Agreements, will be specified to ensure applicable criteria are met. The nuclear owner will be responsible for reinforcements necessary to comply with criteria that are specific to the Nuclear Plant and that are more stringent than the standard PJM and Transmission Owner tests.

The specific nuclear unit planning criteria contained in the NPIR documents are included in the Appendix to this Attachment G when the nuclear plant owner has consented to these excerpts being included here for convenient planning reference. In any instances of a nuclear plant owner preference to maintain confidentiality of this information, it is not reproduced in this manual but is still evaluated and enforced during planning studies.

### **G.9.3 BG&E Specific Criteria**

Additional stability testing applicable to interconnections with BG&E transmission facilities includes tests of three-phase faults at a point 80% of the circuit impedance away from the station under study with delayed (zone two) clearing.

### **G.9.4 ComEd Specific Criteria**

Additional stability testing applicable to interconnections with ComEd transmission facilities includes:

- Three-phase fault on any transmission or generation element with delayed clearing due to a stuck breaker or other protective equipment failure. For situations involving independent pole operated breakers, it is assumed that only one phase of the breaker fails to open and the delayed clearing time is used for the remaining single-phase fault.
- Three-phase fault on any transmission or generation element with delayed clearing due to failure of a special protection system.
- Three-phase fault on all transmission lines on a multiple circuit tower with normal clearing.
- Three-phase fault on any transmission or generation element during the scheduled outage of any other transmission or generation element.

It should be noted that a one-cycle margin is included in all primary-clearing times for faults on the ComEd system, instead of the PJM margins. For more severe, lower probability events such as faults occurring during maintenance outages or faults cleared in delayed time, if lower cost remedies are not available, PJM will retest with the PJM's standard margins as a possible remedy.

### **G.9.5 PPL Specific Criteria**

Additional stability testing applicable to interconnections with PPL transmission facilities includes:

- permanent three-phase faults at a point 80% of the line impedance away from the PPL zone generating facility under consideration with delayed (Zone 2) clearing times, including reclosing, if applicable.
- Permanent three phase fault with stuck breaker or other cause of delayed clearing.
- Permanent three phase fault on one line in the substations one substation removed from the interconnection point with an over-trip of another unfaulted line in the same station. Both the over-trip and clearing of the faulted line occur in normal primary clearing time. Reclosing sequences, if applicable, will be included.
- PPL EU applies a transient synchronous stability safety margin of 7% in the export limited Northern PPL area (see PJM Manual 03 at <http://www.pjm.com/documents/manuals.aspx>). This implies that the net export limit based on stability will be reduced by 7% to account for a margin of error in the specified net export limit from the area.

### **G.9.6 Implementation of the NPIR for Planning Analysis**

PJM is required to incorporate the Nuclear Plant Interface Requirements (NPIRs) into its planning processes according to the applicable NERC standards. PJM performs these planning analyses consistent with the NPIR planning requirements and its Regional Transmission



Planning requirements. PJM Manuals 14B and 39 are the two principal sources that document these requirements, among various other planning and operating process business rules. It is the responsibility of the Planning engineer to monitor changes to the planning requirements contained in the NPIR source documents (kept in confidence by PJM System Operating) and Manual 39 and to update this manual to reflect changes as appropriate per the protocols of Manual 39 section 3.1.

The following material are the excerpted planning requirements and criteria contained in the NPIR's that must be incorporated into PJM Planning analyses. This material must only be changed to be consistent with the source documents.

## **Braidwood Station, Units 1 and 2 Planning Requirements**

**Nuclear Plant Voltage Adequacy Studies:** Periodic analysis of the expected Braidwood switchyard voltages following a unit trip (Unit 1 or 2) shall be performed for various transmission system load levels and contingencies based on the study template provided by Exelon Nuclear. Exelon Nuclear will periodically request these studies from the ComEd transmission entity on a periodic basis to support compliance with GDC 17. The results of the studies are to be provided to Exelon Nuclear by the ComEd Transmission Entity.

**PJM Planning and Operations transmission studies** shall incorporate the Braidwood voltage and stability requirements that follow. Exelon Nuclear shall be notified by the Planning Authority if planning study results identify that the Braidwood requirements are not met by current or future system configurations, load levels, and contingencies. Transmission study violations based on standard PJM criteria testing will be handled by the procedures described in the PJM agreements and manuals. Study violations based on criteria that are specified specifically for Braidwood and are beyond standard PJM criteria testing will require remedies that will be the plant owner's responsibility. The following Braidwood requirements shall be utilized for the planning studies:

Voltage and Offsite Source Load Capacity Requirements:

The Braidwood Voltage Operating Limits, which are based upon internal plant limitations reflected at the transmission system voltage limit level, are as follows:

345kV: Normal Low (actual voltage evaluations) – 349.2kV (1.0122)

Emergency Low (contingency voltage evaluations) – 349.2kV (1.0122)

Note:

The limits above are applicable for Braidwood Units 1 and 2. It is acceptable that the Normal Low limit be conservatively adjusted upward by 1kV to allow for design limitations of the transmission entity state estimators. Some state estimator designs do not allow a Normal Low limit and an Emergency Low limit to be the same value.

For the purposes of the planning studies only the Braidwood unit trip contingency voltage limit requires evaluation. Other transmission system contingencies do not require evaluation.

Stability:

Braidwood generating units 1 and 2 are to be stable for the following conditions (the following are included in PJM standard stability testing):

- A three-phase line fault with normal clearing of the line protective systems.
- A phase-to-ground fault with abnormal (delayed) clearing involving the failure of a relay or circuit breaker.
- A double line tower fault.

Exelon Nuclear shall be notified by the Planning Authority if the results of system stability studies identify that any of the stability requirements discussed above are not met. In addition, Exelon Nuclear shall be notified if the system stability studies pertinent to the Braidwood generators, the Braidwood switchyard, or the lines connecting the Braidwood switchyard to the transmission system indicate that stability requirements contained in the PJM, NERC or ComEd Transmission Entity standards are not met.

## **Byron Station, Units 1 and 2 Planning Requirements**

**Nuclear Plant Voltage Adequacy Studies:** Periodic analysis of the expected Byron switchyard voltages following a unit trip (Unit 1 or 2) shall be performed for various transmission system load levels and contingencies based on the study template provided by Exelon Nuclear. Exelon Nuclear will periodically request these studies from the ComEd transmission entity on a periodic basis to support compliance with GDC 17. The results of the studies are to be provided to Exelon Nuclear by the ComEd Transmission Entity.

**PJM Planning and Operations transmission studies** shall incorporate the Byron voltage and stability requirements that follow. Exelon Nuclear shall be notified by the Planning Authority if planning study results identify that the Byron requirements are not met by current or future system configurations, load levels, and contingencies. Transmission study violations based on standard PJM criteria testing will be handled by the procedures described in the PJM agreements and manuals. Study violations based on criteria that are specified specifically for Byron and are beyond standard PJM criteria testing will require remedies that will be the plant owner's responsibility. The following Byron requirements shall be utilized for the planning studies:

### **Voltage and Offsite Source Load Capacity Requirements:**

The Byron Voltage Operating Limits, which are based upon internal plant limitations reflected at the transmission system voltage limit level, are as follows:

345kV: Normal Low (actual voltage evaluations) – 341.0kV (.9885 pu)

Emergency Low (contingency voltage evaluations) – 341.0kV (.9885 pu)

#### Notes:

The limits above are applicable for Byron Units 1 and 2. It is acceptable that the Normal Low limit be conservatively adjusted upward by .1kV to allow for design limitations of the transmission entity state estimators. Some state estimator designs do not allow a Normal Low limit and an Emergency Low limit to be the same value.

For the purposes of the planning studies only the Byron unit trip contingency voltage limit requires evaluation. Other transmission system contingencies do not require evaluation.

#### Stability:

Byron generating units 1 and 2 are to be stable for the following conditions (the following are included in PJM standard stability testing):

- A three-phase line fault with normal clearing of the line protective systems.
- A phase-to-ground fault with abnormal (delayed) clearing involving the failure of a relay or circuit breaker.
- A double line tower fault.

Exelon Nuclear shall be notified by the Planning Authority if the results of system stability studies identify that any of the stability requirements discussed above are not met. In addition, Exelon Nuclear shall be notified if the system stability studies pertinent to the Byron generators, the Byron switchyard, or the lines connecting the Byron switchyard to the transmission system indicate that stability requirements contained in the PJM, NERC or ComEd Transmission Entity standards are not met.

## **LaSalle Station, Units 1 and 2 Planning Requirements**

**Nuclear Plant Voltage Adequacy Studies:** Periodic analysis of the expected LaSalle Station switchyard voltages following a unit trip (Unit 1 or 2) shall be performed for various transmission system load levels and contingencies based on a study template provided by Exelon Nuclear. Exelon Nuclear will periodically request these studies from the ComEd Transmission Entity on a periodic basis to support compliance with GDC 17. The results of the studies are to be provided to Exelon Nuclear by the ComEd Transmission Entity.

**PJM Planning and Operations transmission studies** shall incorporate the LaSalle voltage and stability requirements that follow. Exelon Nuclear shall be notified by the Planning Authority if planning study results identify that the LaSalle requirements are not met by current or future system configurations, load levels, and contingencies. Transmission study violations based on standard PJM criteria testing will be handled by the procedures described in the PJM agreements and manuals. Study violations based on criteria that are specified specifically for LaSalle and are beyond standard PJM criteria testing will require remedies that will be the plant owner's responsibility. The following LaSalle requirements shall be utilized for the planning studies:

Voltage and Offsite Source Load Capacity Requirements:

The LaSalle Voltage Operating Limits, which are based upon internal plant limitations reflected at the transmission system voltage limit level, are as follows:

345 kV: Normal low (actual voltage evaluations) – 353.0 kV (1.0232 pu)

Emergency Low (contingency voltage evaluations) – 353.0 kV (1.0232 pu)

Note:

The limits above are applicable for LaSalle Units 1 and 2. It is acceptable that the Normal Low limit be conservatively adjusted upward by .1kV to allow for design limitations of the transmission entity state estimators. Some state estimator designs do not allow a Normal Low limit and an Emergency Low limit to be the same value.

For the purposes of the planning studies only the LaSalle unit trip contingency voltage limit requires evaluation. Other transmission system contingencies do not require evaluation.

Stability:

LaSalle generating units 1 and 2 are to be stable for the following conditions (the following are included in PJM standard stability testing):

- A three-phase line fault with normal clearing of the line protective systems.
- A phase-to-ground fault with normal clearing and with abnormal (delayed) clearing involving the failure of a relay or circuit breaker.
- A double line tower fault.
- A phase-to-ground fault during planned transmission line maintenance outages

Exelon Nuclear shall be notified by the Planning Authority if the results of system stability studies identify that any of the stability requirements discussed above are not met. In addition, Exelon Nuclear shall be notified if the system stability studies pertinent to the LaSalle generators, the LaSalle switchyard, or the lines connecting the LaSalle switchyard to the



transmission system indicate that stability requirements contained in the PJM, NERC or ComEd Transmission Entity standards are not met.

## **Quad Cities Nuclear Power Station Units 1 and 2 Planning Requirements**

**Nuclear Plant Voltage Adequacy Studies:** Periodic analysis of the expected Quad Cities switchyard voltages following a unit trip (Unit 1 or 2) shall be performed for various transmission system load levels and contingencies based on the study template provided by Exelon Nuclear. Exelon Nuclear will periodically request these studies from the ComEd Transmission Entity to support compliance with GDC 17. The results of the studies are to be provided to Exelon Nuclear by the ComEd Transmission Entity.

**PJM Planning and Operations transmission studies** shall incorporate the Quad Cities voltage and stability requirements that follow. Exelon Nuclear shall be notified by the Planning Authority if planning study results identify that the Quad Cities requirements are not met by current or future system configurations, load levels, and contingencies. Transmission study violations based on standard PJM criteria testing will be handled by the procedures described in the PJM agreements and manuals. Study violations based on criteria that are specified specifically for Quad Cities and are beyond standard PJM criteria testing will require remedies that will be the plant owner's responsibility. The following Quad Cities requirements shall be utilized for the planning studies.

**Voltage and Offsite Source Load Capacity Requirements:**

The Quad Cities Voltage Operating Limits, which are based upon internal plant limitations reflected at the transmission system voltage limit level, are as follows:

345kV: Normal Low (actual voltage evaluations) – 348.2 kV (1.0093 pu)

Emergency Low (contingency voltage evaluations) – 348.2 kV (1.0093 pu)

Note:

The limits above are applicable for Quad Cities Units 1 and 2.

For the purposes of the planning studies only the Quad Cities unit trip contingency voltage limit requires evaluation. Other transmission system contingencies do not require evaluation.

**Power flow and Stability Testing:**

The following design requirements of the Quad Cities UFSAR are to be annually verified through the battery of transmission tests performed by PJM and ComEd. All of the Quad Cities requirements are embodied in the standard NERC, PJM and ComEd transmission criteria applied during PJM and ComEd studies related to the Regional Transmission Expansion Plan and generation interconnections. These tests ensure the Quad Cities and ComEd system are in compliance with the applicable criteria.

The transmission system is designed to withstand the sudden outage of large amounts of generating capacity. The system shall be designed to compensate for the simultaneous loss of any two generating units and maintain all transmission network flows within short term emergency limits, and all 345kV and 138kV voltages within steady state limits. This is required at all load levels up to the 50/50 load forecast. PJM testing examines the non-simultaneous outage of any two units. ComEd testing examines the most critical combination of simultaneous outages of two units.

Quad Cities Station and the transmission system is designed for stability and circuit isolation that will prevent the sudden loss of one unit at Quad Cities from causing the second unit to trip. This is confirmed by power flow and stability studies. The system shall be stable for situations involving a three phase fault on the most critical generating element with normal clearing, or a

three phase fault on the most critical generating element with delayed clearing, or the loss of the most critical single facility with no fault.

Assuming one or both of the Quad Cities units are tripped when carrying full load, the high voltage lines at the station will continue to be energized from the transmission system. The transmission system shall be designed to withstand the outage of any one generator and maintain all network flows within emergency ratings (up to 50/50 load) or short term emergency ratings (up to 90/10 load).

Exelon Nuclear shall be notified by the Planning Authority (PJM) if the results of system stability studies identify that any of the stability requirements discussed above are not met. In addition, Exelon Nuclear shall be notified if the system stability studies pertinent to the Quad Cities generators, the Quad Cities switchyard, or the lines connecting the Quad Cities switchyard to the transmission system indicate that stability requirements contained in the PJM, NERC or ComEd Transmission Entity standards are not met.

## **Dresden Units 2 and 3 Planning Requirements**

**Nuclear Plant Voltage Adequacy Studies:** Periodic analysis of the expected Dresden Station switchyard voltages following a unit trip (Unit 2 or 3) shall be performed for various transmission system load levels and contingencies based on a study template provided by Exelon Nuclear. Exelon Nuclear will periodically request these studies from the ComEd Transmission Entity on a periodic basis to support compliance with GDC 17. The results of the studies are to be provided to Exelon Nuclear by the ComEd Transmission Entity.

**PJM Planning and Operations transmission studies** shall incorporate the Dresden voltage and stability requirements that follow. Exelon Nuclear shall be notified by the Planning Authority if planning study results identify that the Dresden requirements are not met by current or future system configurations, load levels, and contingencies. Transmission study violations based on standard PJM criteria testing will be handled by the procedures described in the PJM agreements and manuals. Study violations based on criteria that are specified specifically for Dresden and are beyond standard PJM criteria testing will require remedies that will be the plant owner's responsibility. The following Dresden requirements shall be utilized for the planning studies:

### **Voltage and Offsite Source Load Capacity Requirements:**

The Dresden Voltage Operating Limits, which are based upon internal plant limitations reflected at the transmission system voltage limit level, are as follows:

345 kV: Dresden Unit 2 (Blue Bus);

Normal low (actual voltage evaluations) – 332.9 kV (0.9650 pu) with Tr 86 LTC in auto, 346.2 kV (1.0035 pu) with Tr 86 LTC in manual

Emergency Low (contingency voltage evaluations) – 332.9 kV (0.9650 pu) with Tr 86 LTC in auto, 346.2 kV (1.0035 pu) with Tr 86 LTC in manual

345 kV: Dresden Unit 3 (Red Bus);

Normal low (actual voltage evaluations) – 338.8 kV (0.9821 pu) with RAT 32 LTC in auto, 345.3 kV (1.0009 pu) with RAT 32 LTC in manual

Emergency Low (contingency voltage evaluations) – 338.8 kV (0.9821 pu) with RAT 32 LTC in auto, 345.3 kV (1.0009 pu) with RAT 32 LTC in manual

**Note:** For the purposes of the planning studies only the Dresden unit trip contingency voltage limit requires evaluation. Other transmission system contingencies do not require evaluation.

Stability:

Dresden generating units 2 and 3 are to be stable for the following conditions (the following are included in PJM standard stability testing):

A three-phase fault on any transmission or generation element with normal clearing of the protective systems.

- a. A three-phase fault on any transmission or generation element with abnormal (delayed) clearing involving the failure of a relay or circuit breaker. The fault is cleared in delayed time by back-up equipment. If the protective device which fails to operate is an independent pole operated (IPO) breaker, only one phase will be assumed to fail to clear in the primary clearing attempt which will leave only a single phase fault during the delayed clearing time. Mitigation for unstable scenarios may include generator tripping.

- b. A three phase fault on any transmission or generation element accompanied by the failure of a special protection scheme to detect, clear, or properly respond to the fault. The fault is cleared in delayed time by back-up equipment, or the special protection scheme may fail to operate as designed. Mitigation for unstable scenarios may include generator tripping.
- c. A three phase fault on all transmission lines installed on a multiple circuit tower. No relay or circuit breaker failure is assumed for this contingency.
- d. A three phase fault on any transmission or generation element during the scheduled outage of any other transmission or generation element. No relay, circuit breaker, or special protection scheme failure is assumed for this contingency. Mitigation for unstable scenarios may include generator tripping.

Exelon Nuclear shall be notified by the Planning Authority if the results of system stability studies identify that any of the stability requirements discussed above are not met. In addition, Exelon Nuclear shall be notified if the system stability studies pertinent to the Dresden generators, the Dresden switchyard, or the lines connecting the Dresden switchyard to the transmission system indicate that stability requirements contained in the PJM, NERC or ComEd Transmission Entity standards are not met.



## Oyster Creek Unit 01 Planning Requirements

Nuclear Plant Voltage Adequacy Studies: (FirstEnergy responsibility) Periodic analysis of the expected station switchyard voltages following a unit trip shall be performed for various transmission system load levels and contingencies to support station compliance with GDC 17. The bulk transmission system must be examined for performance during system disturbances; using normal case load flows, transient stability studies, and post-transient load flow studies. The studies are to confirm that the system performs adequately for the predicted worst case single contingency (one line or other failure) on the bulk transmission system with normal system adjustments, followed by the loss of the Oyster Creek generator. For these conditions, the studies must confirm that there was no loss of load in the system, the Oyster Creek 230kV substation is not interrupted, and a predicted minimum grid (substation) voltage is determined. Once per year any changes made to the transmission system that would affect voltage stability at Oyster Creek must be reviewed and if necessary, a new value for the minimum expected/predicted grid voltage is to be provided to Exelon Nuclear. Results of the studies are to be provided to Exelon Nuclear.

Transmission Planning studies (PJM responsibility) shall incorporate the voltage and stability requirements of the station. These studies shall include those performed for Operations and for future transmission and generation interconnection. Exelon Nuclear shall be notified if planning study results identify that the station requirements are not met by current or future system configurations, load levels, and contingencies. The following station requirements shall be utilized for the planning studies:

Voltage and Offsite Source Load Capacity Requirements:

The Oyster Creek voltage limits, which are based upon internal plant limitations reflected at the transmission system voltage limit level, are as follows:

	230kV Oyster Creek Switchyard Voltage
Normal Low (actual voltage evaluations)	227kV (0.9869 p.u.)
Emergency Low (contingency voltage evaluations)	223.7kV (0.9726 p.u)

**Note:** For the purposes of the planning studies only the Oyster Creek unit trip contingency voltage limit requires evaluation. Other transmission system contingencies do not require evaluation.

Planning assessments enforce nuclear voltage criteria at the Transmission System level, including any voltage drop criteria. Criteria are enforced on a post-contingency basis without system adjustments but allowing generation reactive supply within normal reactive limits, except as may be explicitly noted below.

Oyster Creek system normal (reference case conditions) 230 kV low voltage limit is 227 kV (.987 pu) and, under contingency conditions it is 223.7 kV (.973 pu). In addition, frequency will be monitored for all studied contingencies and verified to be maintained above 57.5 Hz.



**Stability Requirements:**

The system shall remain stable and perform within voltage and other applicable criteria following:

1. A 3 phase fault with primary clearing on the most critical of the 230 kV lines emanating from Oyster Creek. (standard PJM test)
2. A 3 phase fault with primary clearing on the most critical of the 34.5 kV lines emanating from Oyster Creek. (standard PJM test applied to lower voltage than PJM's standard testing)
3. A 1 phase fault on the most critical of the two 230 kV lines emanating from Oyster Creek, followed by a stuck breaker and clearing in backup clearing time. (standard PJM test)
4. The simultaneous loss of the Oyster Creek generating unit and the largest generating unit in New Jersey (Salem Unit 2) with no faults. (not part of standard testing)
5. 3 phase close-in fault on the most critical 230 kV and above lines from the station (double circuit tower outage, specifically both Manitou-Oyster Creek lines) and loss of the Oyster Creek generator (verify Oyster Creek unit trips based on out-of-step relay protection), (standard PJM test)

Exelon Nuclear shall be notified by the Planning Authority if the results of system stability studies identify that any of the stability requirements discussed above are not met.



### **Three Mile Island Unit 1 Planning Requirements**

**Nuclear Plant Voltage Adequacy Studies:** (FirstEnergy responsibility) Periodic analysis of the expected Station switchyard voltages following a unit trip shall be performed for various transmission system load levels and contingencies to support Station compliance with GDC 17. The bulk transmission system must be examined for performance during system disturbances; using normal case load flows, transient stability studies, and post-transient load flow studies. The studies are to confirm that the system performs adequately for the predicted worst case single contingency (one line or other failure) on the bulk transmission system with normal system adjustments, followed by the loss of the TMI generator. For these conditions, the studies must confirm that there was no loss of load in the system, the TMI 230kV substation is not interrupted, and a predicted minimum grid (substation) voltage is determined. Once per year any changes made to the transmission system that would affect voltage stability at TMI must be reviewed and if necessary, a new value for the minimum expected/predicted grid voltage is to be provided to Exelon Nuclear. Results of the studies are to be provided to Exelon Nuclear.

**Transmission Planning studies** (PJM responsibility) shall incorporate the voltage and stability requirements of the Station. These studies shall include those performed for Operations and for future transmission and generation interconnection. Exelon Nuclear shall be notified if planning study results identify that the Station requirements are not met by current or future system configurations, load levels, and contingencies. The following Station requirements shall be utilized for the planning studies:

Voltage:

The TMI Station voltage limits, which are based upon internal plant limitations reflected at the transmission system voltage limit level, are as follows:

	2 Auxiliary Transformer Operation	Single Auxiliary Transformer Operation	Manual Load Tap Changer Operation
Normal Low	223 (0.9710 pu)	223 (0.9710 pu)	223 (0.9710 pu)
Emergency Low	223 (0.9710 pu)	223 (0.9710 pu)	223 (0.9710 pu)

Planning assessments enforce nuclear voltage criteria at the Transmission System level, including any voltage drop criteria. Criteria are enforced on a system normal and post-contingency basis after allowance for full system adjustments that can be available within 30 minutes following a disturbance.

Stability:

Three Mile Island generating unit stability is to be analyzed according to the applicable NERC, Regional Entities of NERC, and PJM criteria for transient stability.

Exelon Nuclear shall be notified if the results of system stability studies identify that any of the stability requirements discussed above are not met. In addition, Exelon Nuclear shall be notified if the system stability studies pertinent to the TMI generator, the TMI switchyard, or the lines connecting the TMI switchyard to the transmission system indicate that any of the stability requirements are not met.

## **Limerick Generating Station Units 1 and 2 Planning Requirements**

**Nuclear Plant Voltage Adequacy Studies:** Periodic analysis of the expected Limerick switchyard voltages following a unit trip (Unit 1 or 2) shall be performed for various transmission system load levels and contingencies based on the study template provided by Exelon Nuclear. Exelon Nuclear will periodically request these studies from the PECO Transmission Entity to support compliance with NRC licensing commitments for Limerick. The results of the studies are to be provided to Exelon Nuclear by the PECO Transmission Entity.

**PJM Planning and Operations transmission studies** shall incorporate the Limerick voltage and stability requirements that follow. Exelon Nuclear shall be notified by the Planning Authority if planning study results identify that the Limerick requirements are not met by current or future system configurations, load levels, and contingencies. Transmission study violations based on standard PJM criteria testing will be handled by the procedures described in the PJM agreements and manuals. Study violations based on criteria that are specified specifically for Limerick and are beyond standard PJM criteria testing will require remedies that will be the plant owner's responsibility. The following Limerick requirements shall be utilized for the planning studies:

### **Voltage and Offsite Source Load Capacity Requirements:**

The Limerick Voltage Operating Limits, which are based upon internal plant limitations reflected at the transmission system voltage limit level are as follows:

230kV: Normal Low (actual voltage evaluations) – 225kV (.9783 p.u.)

Emergency Low (contingency voltage evaluations) – 225kV (.9783 p.u.)

Voltage drop: 2.5% (Post contingency voltage drop limit to be applied for a contingency trip of Limerick Unit 1 or Unit 2).

500kV: Normal Low (actual voltage evaluations) – 500kV (1.0 p.u.)

Emergency Low (contingency voltage evaluations) – 500kV (1.0 p.u.)

Voltage drop: 2.5% (Post contingency voltage drop limit to be applied for a contingency trip of Limerick Unit 1 or Unit 2).

69kV: Normal Low (actual voltage evaluations) – 67.5kV (.9783 p.u.)

Voltage drop: 3.4% (Post contingency voltage drop limit to be applied for a contingency trip of Limerick Unit 1 or Unit 2).

Note: The 69kV voltage limits are to be activated when notification is received from Exelon Nuclear that the Limerick 69kV source is in operation.

Note: For the purposes of the planning studies only the Limerick unit trip contingency voltage limit requires evaluation. Other transmission system contingencies do not require evaluation.

### **Stability Requirements:**

Limerick Generating Station (LGS) Units 1 and 2 are to be stable for the following conditions:

- a. A three-phase fault on any single 500 kV or 230 kV circuit terminating in the Limerick 500kV or 230kV switchyards that is cleared by primary protective equipment (standard PJM test.)

- b. A three-phase fault on any single 500 kV or 230 kV circuit terminating in the Limerick 500kV or 230kV switchyards, where the most critical LGS circuit breaker fails to open and the fault is cleared at LGS by backup protective equipment. (beyond standard PJM testing.)
- c. A three-phase fault on the transformer connecting the LGS 500 kV and 230 kV buses that is cleared by primary protective equipment (standard PJM test.)
- d. A three-phase fault on the transformer connecting the LGS 500 kV and 230 kV buses, where the most critical circuit breaker fails to open and the fault is cleared at LGS by backup protective equipment. (beyond standard PJM testing.)
- e. Simultaneous three-phase faults on both LGS to Whitpain 500 kV circuits that are cleared by primary protective equipment (beyond standard PJM testing.)

In addition, the transmission system shall remain stable for the following three cases with either one or both LGS units in service. (All the following are beyond standard PJM testing):

- a. Loss of the largest generating station (i.e., loss of Peach Bottom Atomic Power Station (PBAPS) Units 2 and 3) (No faults applied).
- b. Loss of the largest load (No faults applied).
- c. Loss of the most critical right-of-way (i.e., four simultaneous three-phase faults on the four transmission lines on the 130-30 right-of-way):
  - 1. Cromby-Perkiomen (130-30) 138 kV Line
  - 2. Cromby-Upper Providence (220-62) 230 kV Line
  - 3. Limerick-Whitpain (5030) 500kV Line
  - 4. Limerick-Whitpain (5031) 500kV Line

Exelon Nuclear shall be notified by the Planning Authority if the results of system stability studies identify that any of the stability requirements discussed above are not met. In addition, Exelon Nuclear shall be notified if PJM system stability studies pertinent to the Limerick generators, the Limerick switchyards, or the lines connecting the Limerick switchyards to the transmission system indicate that any of the stability requirements contained in the PJM, NERC or PECO Transmission Entity standards are not met.

## **Peach Bottom Station Units 2 and 3 Planning Requirements**

### Nuclear Plant Voltage Adequacy Studies:

Periodic analysis of the expected Peach Bottom offsite power source voltages following a unit trip (Unit 2 or 3) shall be performed for various transmission system load levels and contingencies based on a study template provided by Exelon Nuclear. Exelon Nuclear will periodically request these studies from the PECO Transmission Entity to support compliance with NRC licensing commitments for Peach Bottom. The results of the studies are to be provided to Exelon Nuclear by the PECO Transmission Entity.

PJM Planning and Operations transmission studies shall incorporate the Peach Bottom voltage and stability requirements that follow. Exelon Nuclear shall be notified by the Planning Authority if planning study results identify that the Peach Bottom requirements are not met by current or future system configurations, load levels, and contingencies. Transmission study violations based on standard PJM criteria testing will be handled by the procedures described in the PJM agreements and manuals. Study violations based on criteria that are specified specifically for Peach Bottom and are beyond standard PJM criteria testing will require remedies that will be the plant owner's responsibility. The following Peach Bottom requirements shall be utilized for the planning studies:

### Voltage and Offsite Source Load Capacity Requirements:

The Peach Bottom Station Voltage Operating Limits, which are based upon internal plant limitations reflected at the transmission system voltage limit level are as follows:

#### 2SU: (Peach Bottom Tap on 220-08 line)

Normal Low (actual voltage conditions)- 225kV (.9783 p.u.)

Emergency Low (contingency voltage conditions)- 225kV (.9783 p.u.)

Voltage Drop: 1.8% (Post contingency voltage drop limit to be applied for a contingency trip of Peach Bottom Unit 2 or 3).

Maximum - 242kV (1.05 p.u.)

#### 343SU: (Peach Bottom 230kV; Peach Bottom terminal of 220-34 line)

Normal Low (actual voltage conditions)- 225kV (.9783 p.u.)

Emergency Low (contingency voltage conditions)- 225kV (.9783 p.u.)

Voltage Drop - 2.6% (Post contingency voltage drop limit to be applied for a contingency trip of Peach Bottom Unit 2 or 3).

Maximum - 242kV (1.05 p.u.)

#### 3SU: (13kV tertiary of Peach Bottom #1 transformer)

Normal Low (actual voltage conditions)- 13.5kV

Emergency Low (contingency voltage conditions)- 13.5kV

Voltage Drop - 2.5% (Post contingency voltage drop limit to be applied for a contingency trip of Peach Bottom Unit 2 or 3).

Maximum – 538kV (1.0760 p.u.)(on 500kV side of Peach Bottom #1 Autotransformer)

Note: The limits above are applicable for Peach Bottom Units 2 and 3.



#### Stability Requirements:

Stability studies shall have simulated 500 kV and 230 kV transmission line faults, the loss of each of the Peach Bottom generators, and the loss of the largest generator on the 500 kV grid. The studies must show that the transmission system is stable and there will be no cascading transmission outages for the simulated transmission line faults. The studies must show that continuous offsite power is assured for the simulated transmission system contingencies. This requirement is demonstrated by showing that offsite power sources 2SU, 343SU, and 3SU are maintained in service unless the simulated transmission system contingency is the direct supply to the offsite power source.

Exelon Nuclear shall be notified by the Planning Authority if the results of system stability studies identify that any of the stability requirements discussed above are not met. In addition, Exelon Nuclear shall be notified if PJM system stability studies pertinent to the Peach Bottom generators, the Peach Bottom switchyards, the lines connecting the Peach Bottom switchyards to the transmission system, or the 220-08 line indicate that any of the stability requirements contained in the PJM, NERC or PECO Transmission Entity standards are not met.



### Susquehanna Station units 1 & 2 Planning Requirements

Nuclear Plant Voltage Adequacy Studies: Periodic analysis of the expected Susquehanna switchyard voltages following a unit trip (Unit 1 or 2) shall be performed considering peak transmission system load levels with the system normal or altered by contingencies. Results of the studies are to be provided to PPL Susquehanna. To satisfy this requirement, the PJM normal course of planning studies fulfills this requirement.

Transmission Planning Studies shall incorporate the voltage and stability requirements of Susquehanna. These studies shall include those performed to evaluate future transmission and generation interconnection. PPL Susquehanna shall be notified if planning study results identify that the Susquehanna requirements are not met by current or future system configurations, load levels, and contingencies.

The Transmission Planner or Transmission Owner will perform voltage analysis using a "current year + 5" planning horizon 50-50 peak summer load flow case considering N-1, stuck breaker and tower outage contingencies on 230 kV facilities and above and a stability study (following transmission normal stability criteria along with the special stability cases identified in the FSAR (Section 8.2)). These studies are to be completed on a three year cycle by the Transmission Planner and on a two year cycle by the Transmission Owner, or sooner, if system changes dictate. The Transmission Planner or Transmission Owner will communicate the results of these studies to PPL SSES. These studies may include load flow, voltage and/or stability related work analyses.

The following Susquehanna requirements shall be utilized for the planning studies:

#### **SSES Transformer Loading**

	<u>T-10</u>	<u>T-20</u>	<u>T-11</u>	<u>T-12</u>
Normal Plant Loading	5 + J3	5 + J3	42 + J24	42 + J24
Post Unit 1 Trip Loading both Start-up transformers in-service	27.1 +J14.65	27.1 +J14.65		42 + J24
Post Unit 2 Trip Loading both Start-up transformers in-service	27.1 +J14.65	27.1 +J14.65	42 + J24	
Post Unit 1 Trip Loading T-10 Start-up transformer in-service	54.2 +J 29.3			42 + J24
Post Unit 2 Trip Loading T-10 Start-up transformer in-service	54.2 +J 29.3		42 + J24	
Post unit 1 Trip Loading T-20 Start-up transformer in-service		54.2 +J 29.3		42 + J24
Post Unit 2 Trip Loading T-20 Start-up transformer in-service		54.2 +J 29.3	42 + J24	

Monitor offsite circuits with/without one S/U transformer in service.

With **both** Start-up Transformers (T-10 & T-20) in-service

<u>Minimum Voltage</u>	<u>Allowable Voltage Drop*</u>
212kV (0.9217)	5%

With **one** Start-up Transformer (T-10 or T-20) in-service

<u>Minimum Voltage</u>	<u>Allowable Voltage Drop*</u>
216.7kV (0.9421)	2%

\*Post contingency voltage drop limit to be applied for a contingency trip of Susquehanna unit 1 or unit 2.

**NOTE:** Voltage excursions below the Susquehanna voltage limits with durations expected to be greater than 9 seconds will result in the affected unit or units transferring from offsite power to the onsite power distribution system. Therefore, the transmission Entities shall take into consideration actions that will mitigate voltage excursions below the Susquehanna minimum voltage limits with durations greater than 9 seconds and provide notification when proposed actions cannot mitigate the voltage excursion.

Stability:

Susquehanna generating units 1 and 2 are to be stable for the following conditions:

In general, the stability requirements are that the system shall be maintained without loss of non-consequential load during and after the following types of contingencies based on the latest light load forecast prepared annually by the PJM Load Analysis Subcommittee.

Standard NERC criteria contingencies (identified as R-\* cases of FSAR Table 8.2-1):

- Single contingency outage conditions
- Double circuit tower line outage or single stuck circuit breaker conditions  
Three phase faults with normal clearing time
- Single line to ground faults with a stuck breaker or other cause for delayed clearing

The NERC TPL Standard reliability criteria also requires an evaluation of the ability of the bulk electric system to withstand abnormal or extreme system disturbances (identified as the N-\* cases of FSAR Table 8.2-1). The NERC TPL Standard reliability criteria does not require that the bulk electric system be planned and constructed to withstand these abnormal or extreme disturbances due to their low probability of occurrence. However, it is PPL SSES position to maintain stability for these FSAR Table 8.2-1 cases as well. These abnormal system disturbances are analyzed not on the basis of their likelihood of occurrence but rather as a practical means to study the system for its ability to withstand disturbances beyond those that can be reasonably expected.

A total of six (6) contingencies identified in the FSAR Table 8.2-1 are required by NERC standards. Seventeen (17) other contingencies are not required by NERC standards but analyzed to assure a high level of transmission system reliability. FSAR table 8.2-1 is attached with the list of stability cases performed for PPL Susquehanna LLC. PPL Susquehanna shall be notified if the results of system stability studies identify that any of the stability requirements discussed above are not met. In addition, PPL Susquehanna shall be notified if the system



stability studies indicate that any of the stability requirements contained within the attached stability summary tables is not met.



CASE	DESCRIPTION
R-1	3 phase fault at Susquehanna 500 kV on the Sunbury 500 kV line. Fault cleared in primary clearing time.
R-5	Phase-ground fault at Susquehanna 500 kV on Sunbury 500 kV line with Sunbury South 500 kV circuit breaker stuck. Clear remote terminal in primary time. Delayed clearing of Susquehanna.
R-6	3 phase fault at Susquehanna 230 kV on the Susquehanna 500/230 kV transformer. Fault cleared in primary clearing time.
R-7	3 phase fault at Montour 230 kV on Susquehanna 230 kV line. Fault cleared in normal primary clearing time.
R-13	Phase-ground fault at Susquehanna 500 kV on Susquehanna-Wescosville-Alburtis 500 kV line with Wescosville South 500 kV circuit breaker stuck. Clear remote terminal in primary time. Delayed clearing at Susquehanna.
R-18	3 phase fault at Susquehanna 230 kV on Harwood #1 & #2 Double Circuit. Fault cleared in primary clearing time.
N-2	3 phase fault at Susquehanna 500 kV on the Sunburn 500 kV line with one breaker pole stuck at Sunbury. Clear Susquehanna in primary time. Delayed clearing at remote terminal.
N-3	3 phase fault at Susquehanna 500 kV on the Susquehanna-Wescosville-Alburtis 500 kV line with one Susquehanna 500/230 kV transformer breaker pole stuck. Clear remote terminal in primary time. Delayed clearing of Susquehanna.
N-4	3 phase fault at Susquehanna 500 kV on the Sunbury 500 kV line with one Susquehanna 500/230 kV transformer breaker pole stuck. Clear remote terminal in primary time. Delayed clearing of Susquehanna.



N-8	3 phase fault at Susquehanna 230 kV on Montour line with stuck west bus breaker. Clear remote terminal in primary time, clear Susquehanna with delay (lose Stanton-Susquehanna #2 230 kV line).
N-9	3 phase fault at Susquehanna 230 kV on Jenkins line with stuck east bus breaker. Primary clearing at remote terminal. Delayed clearing at Susquehanna.
N-10	3 phase fault at Susquehanna 230 kV on the 500/230 kV transformer with stuck west bus breaker pole. Clear two poles in primary time. Primary clearing at remote terminal (Susquehanna 500 kV Switchyard). Clear stuck pole in delayed clearing time (lose Stanton-Susquehanna #2 230 kV line).
N-11	3 phase fault at Susquehanna 230 kV on Harwood #1 line with stuck tie breaker pole. Clear two poles in primary time. Clear stuck pole in delayed clearing time (lose Sunbury-Susquehanna 230 kV line).
N-12	3 phase fault at Susquehanna 230 kV on Harwood #2 line with one pole stuck on west bus breaker. Clear two poles in primary time. Clear stuck pole in delayed clearing time (lose Stanton-Susquehanna #2 230 kV line).
N-14	Susquehanna-Wescosville-Alburtis 500 kV and Susquehanna-Harwood #1 & #2 Double Circuit 230 kV crossing failure (3 phase fault on all circuits). Automatically trip Susquehanna Unit #1. Clear Susquehanna-Wescosville-Alburtis 500 kV line in primary time. Clear Susquehanna- Harwood #1 & #2 230 kV lines in primary time.
N-15	3 phase fault near E. Palmerton on all lines in E. Palmerton-Harwood R/W corridor. Clear Susquehanna-Wescosville-Alburtis 500 kV line in primary time. Primary clearing of E. Palmerton-Harwood and Harwood-Siegfried 230 kV lines.
N-16	3 phase fault near Susquehanna on both lines in Sunbury-Susquehanna R/W corridor. Clear Sunbury-Susquehanna #2 500 kV line in primary time. Primary clearing of Sunbury-Susquehanna #1 230 kV line.



N-17	3 phase fault near Susquehanna 500 kV at Sunbury 230 kV line crossing. Trip Susquehanna – Wescosville-Alburtis 500 kV, Sunbury-Susquehanna #2 500 kV, and Unit #2 in primary time. Trip Sunbury-Susquehanna #1 230 kV in primary clearing time.
N-19	3 phase fault at Columbia-Frackville 230 kV line crossing. Trip Sunbury-Susquehanna #2 500 kV line in primary time. Trip Columbia-Frackville and Sunbury-Susquehanna #1 230 kV lines in primary time.
N-20	3 phase fault on 230 kV side of Unit #1 main transformer. Trip Unit #1 main transformer. Trip Unit #1 and overtrip Unit #2 in primary time.
N-21	3 phase fault at Susquehanna 230 kV on Unit #1 generator leads with a stuck west bus breaker. Trip Unit #1 and Stanton #2 line.
N-23	Sudden loss of all lines from Susquehanna 230 kV Switchyard
N-24	3 Phase fault on Susquehanna-Jenkins 230 kV line 80% towards Jenkins with pilot relaying out. Fault cleared in Zone 2 (backup) time at Susquehanna and Zone 1 time at Jenkins.

FSAR table 8.2-1

## **Calvert Cliffs Units 1 and 2 (CCNPP) Planning Requirements**

### Nuclear Plant Voltage Adequacy Studies

At the request of CCNPP, BGE shall perform periodic analysis of expected Calvert Cliffs 500 kV Switchyard post Unit trip voltages. These studies are typically performed on an annual frequency, but could be needed on a more frequent basis. The results of these studies shall be provided to CCNPP by BGE.

### Planning and Operations Transmission Studies

PJM planning and operations transmission studies shall incorporate the Calvert Cliffs 500 kV Switchyard voltage, frequency and capacity requirements in switchyard voltage section below. CCNPP shall be notified by the Planning Coordinator (PJM) if planning study results identify that the Calvert Cliffs 500 kV Switchyard requirements are not met by current or future system configurations, load levels, or contingencies. Transmission study violations based on standard PJM criteria testing will be dispositioned in accordance with the applicable PJM agreements and manuals. Resolution of study violations based on criteria that are specific to CCNPP and are beyond standard PJM criteria testing will be CCNPP responsibility. The following Calvert Cliffs 500 kV Switchyard requirements shall be utilized for the planning studies:

**Voltage and Offsite Source Load Capacity Requirements:** Refer to Section 1 for the voltage and load capacity requirements.

**Stability Requirements:** Stability studies shall have simulated transmission line faults, the loss of each of the CCNPP main generators, and the loss of the largest generator on the 500 kV system. The studies must show that the transmission system is stable and there will be no cascading transmission outages for the simulated transmission line faults. They must also show continuity of offsite power at the Calvert Cliffs 500 kV Switchyard for the simulated transmission system contingencies by ensuring voltage limits defined in section 1.3 are not violated. CCNPP shall be notified by the Planning Authority (PJM) if the results of system stability studies identify if any of the stability requirements are not met.

### Calvert Cliffs 500 kV Switchyard Voltage and CCNPP Frequency Requirements

#### Operating Voltage Limits for the Calvert Cliffs 500 kV Switchyard

<b>Calvert Cliff Voltage Limits</b>		
<b>Plant Service Transformers (P-13000-2 &amp; P-13000-2)</b>	<b>Pre-Contingency</b>	<b>Post-Contingency</b>
Both xfmrs in service	500kV – 550kV	475kV – 550kV
Only one xfmr in service	520kV – 550kV	510kV – 550kV

Note: See maximum post-trip voltage drop below for loss of a CCNPP unit.

#### Calvert Cliffs 500 kV Switchyard Voltage Drop Limit

Maximum post-trip voltage drop (Post-contingency for a single CCNPP unit): Voltage drop of 5% of the pre-trip bus voltage with either one or both P-13000 transformers in service. The 5% post contingency voltage drop limit is to be applied at the Calvert Cliffs 500 kV Switchyard for a contingency trip of CCNPP Unit 1 or Unit 2.



### Short Circuit Calculations

BGE and SMECO shall provide to CCNPP available short circuit current data at the points of interconnection, when requested for use in the CCNPP distribution system short circuit calculations.

## **Beaver Valley Units 1 and 2 Planning Requirements**

Nuclear Station Voltage Adequacy studies: Per Service Agreement No. 1668, Schedule F, paragraph 12: "ATSI (American Transmission Systems Incorporated) will perform a probability study, at FENOC's (FirstEnergy Nuclear Operating Company) expense, by June 1 of each year to determine the frequency of grid voltage outside of values identified in this schedule. This study will include expected power flow transfers through the region that would influence grid voltages." Results of the studies are to be provided to FENOC.

Transmission Planning studies: The Transmission Planner shall incorporate the voltage and stability requirements of BVPS. These studies shall include those performed to evaluate future transmission and generation interconnection in accordance with applicable NERC and Regional Entities of NERC standards. Both FENOC (Akron) and the BVPS Design Engineering staff shall be notified if planning study results identify that the BVPS requirements are not met by current or future system configurations, load levels, and contingencies by the Transmission Planner performing the studies. Transmission study violations based on standard PJM criteria testing will be handled by the procedures described in the PJM agreements and manuals. Study violations based on criteria that are specified specifically for BVPS and are beyond standard PJM criteria testing will require remedies that will be the plant owner's responsibility. The following BVPS requirements shall be utilized for the planning studies:

### **Voltages:**

The voltage limit requirements are as stated below.

The Station voltage limits are as follows:

Beaver Valley Switchyard 345kV Voltage Limits

EL (Emergency Low) 341 kV (0.9850 p.u.)

NL (Normal Low) 343 kV (0.9942 p.u.)

NH (Normal High) 355 kV (1.0290 p.u.)

Beaver Valley Switchyard 138kV Voltage Limits

EL (Emergency Low) 131 kV (0.9493 p.u.)

NL (Normal Low) 136 kV (0.9855 p.u.)

NH (Normal High) 142 kV (1.0289 p.u.)

Planning assessments enforce nuclear voltage criteria at the Transmission System level, including any voltage drop criteria. Criteria are enforced on a system normal and post-contingency basis after allowance for full system adjustments that can be available within 30 minutes following a disturbance.

### **Frequency:**

Both BVPS-1 and BVPS-2 require a stable grid frequency of 59.9 to 60.1 Hz.

### **Stability:**

BVPS generating unit stability is to be analyzed according to the applicable NERC, and Regional Entities of NERC, criteria for transient stability. The analyzed contingencies that are evaluated against Beaver Valley's voltage requirements include:



- Loss of a significant generating unit (standard PJM testing)
- Loss of a significant transmission line (standard PJM test), or
- Loss of a Beaver Valley unit (standard PJM test)

BVPS and FENOC (Akron) shall be notified by the Transmission Planner performing the studies if the results of system stability studies identify that any of the stability requirements discussed above are not met.

## **Cook Unit 1 and 2 Planning Requirements**

The following requirements are derived from Cook Plant Design Information Transmittal DIT-B-03036-00. The information in this DIT is to be used to perform transmission studies that support Cook Plant Operation.

This DIT looks at case reports for Mode 1 and LOCA. The purpose is to allow a comparison between plant data and the model (Mode 1) and make adjustments to the model if appropriate. These values will be transmitted to Transmission planning as input for their studies.

Depending on the preferred power line up (split = Transformer #4 and Transformer #5; Transformer #4 only; or Transformer #5 only) different values for transfer must be considered. The "split" lineup will transfer the IA & IB or 2A & 2B busses to Transformer #5 and the IC & ID or 2C & 2D busses to Transformer #4. The transfer includes the associated T-busses. These groups of loads (load groups) are called Division AB and Division CD for each unit. When the preferred power lineup is Transformer #4 only or Transformer #5 only; then both divisions (AB and CD) will transfer to the applicable single transformer. The single transformer load group is called "Entire Plant" and consists of the Division AB and Division CD for a single unit. This DIT also looks at 69kv power requirements.

### **3. Design Value Determination**

- 3.1. The values determined above are increased to allow increased use of power within the plant and for margin. The amount of the increase was determined by engineering judgement considering weld receptacles and desired margins. All power magnitudes are assumed to be at 0.8 power factor. This is reasonable since the current plant model shows power factor slightly above 0.8.

	<b>Accident Megawatt Load</b>		
	<b>AB Division</b>	<b>CD Division</b>	<b>Entire Plant</b>
<b>Unit 1</b>	22	22	42
<b>Unit 2</b>	20	24	42.5

- 3.2. The division power levels should be used for the normal split lineup of the switchyard when the AB division will be powered via transformer 5 and the CD division will be powered via transformer 4. The division power levels cannot be added together to represent the entire plant because the division power values are representative of different plant lineups where depending on which pumps are in service power can be shifted from one division to another. The total power levels should be used when the switchyard is lined up in either the Transformer4 only or transformer 5 only lineups.

### **4. 69kv System Determination**

- 4.1. Power for the 69kv system is procedurally limited to 600 amperes at the 4kv level for each unit (Ref 4). This power would be in addition to the normal load seen on 69kv. The normal load consists of power to other buildings at the site such as the Training Center and the Visitors Center. Actual power factor is expected to be between 0.8 and 0.9. The value which results in the lowest voltage should be selected for conservatism.
- 4.2. Since the primary result from determining these values is the evaluation of voltage adequacy and the limitation is an absolute value for current; available power will reduce with available voltage.

- 4.3. The bounding case of determining minimum adequate voltage will be when system conditions are such that the minimum acceptable voltage results from applying the power allowed at that voltage via the EP (69kv source).
- 4.4. The lowest allowable voltage is cited in the TRM as 91%.
- 4.5. The power for the bounding case is  $1200 \times 0.91 \times 4160 \times 1.73 \times \text{pf} = 7.86 \times \text{pf}$  (MW)

## 5. Conclusions for Transmission Planning Studies

- 5.1. The power transferred to our 34kv system will depend on the lineup of the system. The normal lineup is split so that the AB division will transfer to TR5 and the CD division will transfer to TR4. If either transformer is out of service then the entire unit will transfer to the remaining transformer (TR5 and TR4 only lineups). The following table prescribes the value to be used for transmission studies. The power factor associated with these loads is 0.80.

	<b>Megawatt Load Transferred at Unit Trip</b>		
	<b>AB Division (TR5 split)</b>	<b>CD Division (TR4 split)</b>	<b>Entire Plant (TR5 or TR4 only)</b>
<b>Unit 1</b>	22	22	42
<b>Unit 2</b>	20	24	42.5

- 5.2. The power that can be transferred to the 69kv system is  $7.86 \times \text{power factor}$  (MW). The power factor between 0.80 and 0.90 which provides the lowest voltages should be selected.

Using the input data described above, periodic planning studies are conducted of the transmission and subtransmission networks surrounding the D. C. Cook Plant to determine worst-case offsite power voltage conditions that could credibly exist during a plant shutdown scenario, as well as minimum and maximum voltage and short circuit levels that may be experienced. These studies determine the impact of the most significant factors including transmission and subtransmission network contingencies, Cook Plant generating unit configurations, status of other generation near Cook Plant, 765 kV switched shunt reactor status, and transmission network power flows and take into account the various possible reserve auxiliary switchyard lineups. Available historic data for EHV flows and voltages is utilized in preparation of power flow models used in the studies and for independent validation of study results.

Typically, planning studies will be requested by Cook Plant personnel and performed by AEP Transmission with results provided to Cook Plant and to PJM Planning.

### Voltage Requirement

**TABLE 1**  
**Maximum switchyard voltage swing requirements to reset the degraded voltage relays with the Main Generator Synchronized to the Transmission Network and the buse(s) are powered from the Unit Auxiliary Transformer(s) source:**

Cook Offsite Power Source	34 kV Switchyard Source Breaker position	345 kV System Swyd Swing Limit (Value @ DGR reset.) % of 345kV				TR4 Tertiary 34.5 kV System Swyd Swing Limit (Value @ DGR reset) % of 34.5kV			
		Unit 1		Unit 2		Unit 1		Unit 2	
		Limit Note 1	Alarm Setpoint	Limit Note 1	Alarm Setpoint	Limit Note 1	Alarm Setpoint	Limit Note 1	Alarm Setpoint
TR5 & TR4	BD – Open BE & BC – Closed	<b>5.0%</b> Note 3	<b>4.5%</b> Note 2	<b>3.7%</b> Note 3	<b>3.2%</b> Note 2	<b>5.3%</b> Note 3	<b>4.8%</b> Note 2	<b>3.6%</b> Note 3	<b>3.1%</b> Note 2
TR5	BD & BE - Closed BC – Open	<b>1.1%</b>	<b>0.6%</b> Note 2	<b>0.0%</b>	<b>-0.5%</b> Note 2	N/A	N/A	N/A	N/A
TR4	BD & BC – Closed BE – open	N/A	N/A	N/A	N/A	<b>4.3%</b>	<b>3.8%</b> Note 2	<b>2.5%</b>	<b>2.0%</b> Note 2

**The BOLDED values indicate the limits and alarm values.**

**TABLE 2**  
**Maximum switchyard voltage swing requirements to reset the degraded voltage relays with the Main Generator Synchronized to the Transmission Network and the buse(s) are powered from the Reserve Auxiliary Transformer(s) source:**

Cook Offsite Power Source	34 kV Switchyard Source Breaker position	345 kV System Swyd Swing Limit (Value @ DGR reset.) % of 345kV				TR4 Tertiary 34.5 kV System Swyd Swing Limit (Value @ DGR reset) % of 34.5kV			
		Unit 1		Unit 2		Unit 1		Unit 2	
		Limit Note 1	Alarm Setpoint	Limit Note 1	Alarm Setpoint	Limit Note 1	Alarm Setpoint	Limit Note 1	Alarm Setpoint
TR5 & TR4	BD – Open BE & BC – Closed	<b>1.6%</b>	<b>1.1%</b> Note 2	<b>1.1%</b>	<b>0.6%</b> Note 2	<b>2.4%</b>	<b>1.9%</b> Note 2	<b>2.0%</b>	<b>1.5%</b> Note 2
TR5	BD & BE - Closed BC – Open	<b>1.0%</b>	<b>0.5%</b> Note 2	<b>0.7%</b>	<b>0.2%</b> Note 2	N/A	N/A	N/A	N/A
TR4	BD & BC – Closed BE – open	N/A	N/A	N/A	N/A	<b>1.5%</b>	<b>1.0%</b> Note 2	<b>1.1%</b>	<b>0.6%</b> Note 2

**The BOLDED values indicate the limits and alarm values.**

## **North Anna Units 1 and 2 Planning Requirements**

The Dominion System Operator must notify the station in a timely manner if any of the GDC-17 limits stated in item 1 above may potentially be impacted by the results of Operations Planning studies.

It is the responsibility of Transmission Planning to develop a long-range transmission plan which provides for orderly and timely modifications to the transmission system in order to insure an adequate, economical and reliable supply of electric power. The system must be planned, designed, and constructed to operate reliably within thermal, voltage, and stability limits. Dominion's Transmission Planning performs a wide variety of specific studies to ensure the GDC-17 requirements are met.

These include:

- Power Flow Studies
- Stability Studies

PJM and Dominion Electric Transmission Planning will design the system to meet the GDC-17 requirements. Steady state voltage limits will use the "Emergency Limit Low" and "Emergency Limit High" voltage limits of section 1. Only the following contingency scenarios will be evaluated:

Transmission Condition	Unit 1	Unit 2
All lines in	On	On
All lines in	Trip	On
All lines in	On	Trip
All lines in	Trip	Trip
Worst case N-1 contingency	On	On
Worst case N-1 contingency	Trip	On
Worst case N-1 contingency	On	Trip

PJM/Dominion Electric Transmission Planning will notify Dominion Nuclear of any NPIR criteria violations. Transmission study violations based on standard PJM/Dominion planning criteria will be handled through the normal planning processes described in the PJM agreements and manuals. Upgrades for study violations based on the more stringent Dominion Nuclear NPIR criteria will be the responsibility of the plant owner.

Voltage Limits:

The NAPS 500 kV switchyard voltage must be maintained between 505kV and 535 kV to ensure compliance with GDC-17 voltage analysis. The Dominion System Operator must notify the station in a timely manner (within 15 minutes) when one of the following conditions occurs:

- The 500 kV or 230 kV voltage or frequency limits are exceeded, and the steps taken or being taken to mitigate the exceeded limit.

Bus Name	Normal Limit Low	Emergency Limit Low
500 kV	510.0 kV (1.02 pu)	505.0 kV (1.01 pu)
230 kV	226.3 kV (0.984 pu)	224.0 kV (0.974 pu)

Bus Name	Normal Limit High	Emergency Limit High
500 kV	530.0 kV (1.06 pu)	535.0 kV (1.07 pu)
230 kV	239.2 kV (1.04 pu)	242.0 kV (1.052 pu)

Bus Name	Normal Voltage Drop	Emergency Voltage Drop
500 kV	3.5 %	3.5 %
230 kV	3.5 %	3.5 %

Bus Name	Frequency Limit Low	Frequency Limit High
500 kV	59.5 Hz	60.5 Hz
230 kV	59.5 Hz	60.5 Hz

- A contingency analysis study indicates the normal or emergency limit for the station will be exceeded if a single contingency occurs and the Transmission Operator cannot effectively mitigate the condition to avoid the violation.
- Both the Dominion and the PJM Real Time Contingency Analysis (RTCA) are not available.
- The real time telemetry between Dominion System Operator and the station is known to be out of service.
- The system conditions return to normal.

## **Surry Units 1 and 2 Planning Requirements**

The Dominion System Operator must notify the station in a timely manner if any of the GDC-17 limits stated in item 1 above may potentially be impacted by the results of Operations Planning studies.

It is the responsibility of Transmission Planning to develop a long-range transmission plan which provides for orderly and timely modifications to the transmission system in order to insure an adequate, economical and reliable supply of electric power. The system must be planned, designed, and constructed to operate reliably within thermal, voltage, and stability limits. Dominion's Transmission Planning performs a wide variety of specific studies to ensure the GDC-17 requirements are met. These include:

- Power Flow Studies
- Stability Studies

PJM and Dominion Electric Transmission Planning will design the system to meet the GDC-17 requirements. Steady state voltage limits will use the "Emergency Limit Low" and "Emergency Limit High" voltage limits of section 1. Only the following contingency scenarios will be evaluated:

Transmission Condition	Unit 1	Unit 2
All lines in	On	On
All lines in	Trip	On
All lines in	On	Trip
All lines in	Trip	Trip
Worst case N-1 contingency	On	On
Worst case N-1 contingency	Trip	On
Worst case N-1 contingency	On	Trip

PJM/Dominion Electric Transmission Planning will notify Dominion Nuclear of any NPIR criteria violations. Transmission study violations based on standard PJM/Dominion planning criteria will be handled through the normal planning processes described in the PJM agreements and manuals. Upgrades for study violations based on the more stringent Dominion Nuclear NPIR criteria will be the responsibility of the plant owner.

### Voltage Limits:

The SPS 500 kV switchyard voltage must be maintained between 505 kV and 535 kV to ensure compliance with GDC-17 voltage analysis. Similarly, the 230 kV switchyard voltage must be maintained between 220 kV and 245 kV. The Dominion System Operator must notify the station in a timely manner (within 15 minutes) when one of the following conditions occurs:

- The 500 kV or 230 kV voltage or frequency limits are exceeded, and the steps taken or being taken to mitigate the exceeded limit.

Bus Name	Normal Limit Low	Emergency Limit Low
500 kV	510.0 kV (1.02 pu)	505.0 kV (1.01 pu)
230 kV	222.3 kV (0.967 pu)	220.0 kV (0.957 pu)

Bus Name	Normal Limit High	Emergency Limit High
500 kV	530.0 kV (1.06 pu)	535.0 kV (1.07 pu)
230 kV	239.2 kV (1.04 pu)	245.0 kV (1.065 pu)

Bus Name	Normal Voltage Drop	Emergency Voltage Drop
500 kV	4.5 %	4.5 %
230 kV	6.0 %	6.0 %

Bus Name	Frequency Limit Low	Frequency Limit High
500 kV	59.67 Hz	60.33 Hz
230 kV	59.67 Hz	60.33 Hz

- A contingency analysis study indicates that the normal or emergency limit for the station will be exceeded if a single contingency occurs and the Transmission Operator cannot effectively mitigate the condition to avoid the exceeded limit.
- Both the Dominion and the PJM Real Time Contingency Analysis (RTCA) are not available.
- The real time telemetry between Dominion System Operator and the station is known to be out of service.
- The system conditions return to normal.

## **Hope Creek Unit Planning Requirements**

### **Transmission Planning (PJM)**

Hope Creek Generating Station, operating in the PJM controlled bulk electric system requires periodic transmission planning studies to be performed to ensure onsite power systems remain connected to the offsite power sources during grid transients or a unit trip of Hope Creek or the adjacent Salem generating units.

Periodic analysis of the expected Hope Creek switchyard voltage and voltage drop following a unit trip shall be performed for various transmission system load levels and contingencies.

Studies shall also be performed, as needed, to evaluate the effect that future proposed modifications or changes to the transmission system may have on Hope Creek offsite power source limits.

PSEG Nuclear shall be notified if any of the above planning studies identify that the Hope Creek requirements stated in Section 1 are not met by current or future configurations, load levels, and /or contingencies.

Transmission Planner organization shall provide the 500kV System Equivalent Impedances (min and max) at the Hope Creek switchyard whenever transmission planning studies are performed or as requested by the generating station.

### **Voltage Limits**

Hope Creek Generating Station is analyzed to operate within the following voltage limits:

Emergency Low: 493 KV (0.986 p.u.)

Normal Low: 500 KV (1.000 p.u.)

High Limit: 550 KV (1.100 p.u.)

### **Voltage Drop Requirements**

Hope Creek Generating station has been analyzed for a maximum allowable offsite voltage drop at the station following a unit trip and the worst case post trip accident loading.

2.5% Voltage Drop

### **Stability Requirements**

Hope Creek Generating Station is operated in close proximity with the PSEG Nuclear Salem Units 1 and 2 generating stations and has been analyzed for stability for the following faults provided the station is operated per the Artificial Island Operating Guide (AIOG) A-5-500-EEE-1686:

1. Loss of Hope Creek Generator.
2. Loss of most critical Generating Unit on the Grid
3. Loss of the Most Critical Transmission Line

The Transmission Operator, Transmission Planner and PSE&G Transmission Owner are required to incorporate the requirements of the latest revision of the Artificial Island Operating Guide A-5-500-EEE-1686, into all future stability studies, and provide PSEG Nuclear with at least 24 months notice of any violations to the guide due to future system modifications which could impact generation output at Artificial Island.

## **Salem Units 1 & 2 Planning Requirements**

### **Transmission Planning (PJM)**

Salem Generating Station, operating in the PJM controlled bulk electric system requires periodic transmission planning studies to be performed to ensure onsite power systems remain connected to the offsite power sources during grid transients or a unit trip of Salem or the adjacent Hope Creek generating units.

Periodic analysis of the expected Salem switchyard voltage and voltage drop following a unit trip shall be performed for various transmission system load levels and contingencies.

Studies shall also be performed, as needed, to evaluate the effect that future proposed modifications or changes to the transmission system may have on Salem offsite power source limits.

PSEG Nuclear shall be notified if any of the above planning studies identify that the Salem requirements stated in Section 1 are not met by current or future configurations, load levels, and /or contingencies.

Transmission Planner organization shall provide the 500kV System Equivalent Impedances (min and max) at the Salem switchyard whenever transmission planning studies are performed or as requested by the generating station.

#### Voltage Limits

Salem Generating Station is analyzed to operate within the following voltage limits:

Emergency Low: 493 KV (0.986 p.u.)

Normal Low: 500 KV (1.000 p.u.)

High Limit: 550 KV (1.100 p.u.)

### **Voltage Drop Requirements**

Salem Generating station has been analyzed for a maximum allowable offsite voltage drop at the station following a unit trip and the worst case post trip accident loading.

#### 2.0% Voltage Drop

### **Stability Requirements**

Salem Units 1 and 2 are located in close proximity with the PSEG Nuclear Hope Creek generating station and have been analyzed for stability for the following faults provided the station is operated per the Artificial Island Operating Guide (AIOG) A-5-500-EEE-1686:

1. Loss of One Salem Nuclear Unit
2. Loss of Largest Generating Unit on the Grid
3. Loss of the Most Critical Transmission Line

The Transmission Operator, Transmission Planner and PSE&G Transmission Owner are required to incorporate the requirements of the latest revision of the Artificial Island Operating Guide A-5-500-EEE-1686, into all future stability studies, and provide PSEG Nuclear with at least 24 months notice of any violations to the guide due to future system modifications which could impact generation output at Artificial Island

## G.10 NERC Standard PRC-023 – Transmission Relay Loadability

### Background

The purpose of the standard is to ensure that protective relay settings shall not limit transmission loadability; not interfere with system operators' ability to take remedial action to protect system reliability and; be set to reliably detect all fault conditions and protect the electrical network from these faults. There are a number of requirements that specify how protective relays should be set so that they will not limit loadability of a circuit. One of the requirements of the Standard (R3) is for the Planning Coordinator to identify the 100 kV to 200 kV facilities that must meet Requirement 1 of the standard to prevent potential cascade tripping that may occur when protective relay settings limit transmission loadability. The Planning Coordinator shall have a process to determine the facilities that are critical to the reliability of the Bulk Electric System, maintain a current list of facilities determined according to the process, and provide the list of facilities to its Reliability Coordinators, Transmission Owners, Generator Owners, and Distribution Providers within 30 days of establishment of the initial list and within 30 days of any changes to the list. The process shall consider input from adjoining Planning Coordinators and affected Reliability Coordinators.

### Process to determine PRC-023 Critical Facilities

As part of the development of the RTEP each year PJM staff will perform analysis to determine what facilities may be susceptible to cascading. The test will determine if the simultaneous loss of two independent<sup>5</sup> BES elements (without intermediate system adjustments) results in a 100 kV – 200 kV facility being loaded in excess of 115% of its emergency rating and the loss of that overloaded facility results in additional overloaded BES facilities. If there are additional overloaded BES facilities loaded in excess of their emergency rating, the 100 kV – 200 kV element that was overloaded after the initial N-1-1 will be identified as needing to meet the requirements of the standard.

---

<sup>5</sup> Note that this test methodology is beyond the current requirements of NERC Standard TPL-003 given the standard evaluates common mode failures (i.e. loss of a double circuit tower line, bus, or circuit breaker failure) that result in the loss of two or more facilities. Category C3 in Table 1 of the standard evaluates the loss of independent BES elements however system adjustments can be made following the loss of the first facility.

## Attachment H: Power System Modeling Data

### H.1 Power System Modeling Data

Accurate power system modeling data is a key component of quality power system analysis. PJM System Planning uses a variety of models and analytical techniques to create and maintain the simulation models used for the RTEP studies. The intended use of this Attachment is to supplement existing documentation by PJM and other entities that specify accurate modeling data requirements. PJM will continue to follow the data guidelines and standards set forth by NERC as part of the MOD standards and the Eastern Interconnection Reliability Assessment Group (ERAG) Multiregional Modeling Working Group (MMWG) Procedural Manual.

#### H.1.1 Load Flow Analysis Models

Base case creation is a collaborative process between PJM and its members. From a technical standpoint PJM follows the guidelines set forth in the ERAG MMWG Procedural Manual. In the following sections, the logistics and transfer of information between PJM and its members are detailed.

##### Annual Updates

In the fourth quarter of each year, PJM will distribute to the Transmission Owners a current year +5 summer peak network model based on the most up to date MMWG case combined with the previous year's RTEP case. This draft case will contain all upgrades identified during the previous year's RTEP cycle. Within 4 weeks of receiving the initial draft network model, Transmission Owners will provide:

- Network updates to the model that will advance the case to represent a current year + 5 base case with respect to the 1st Quarter of the following year. This update should be reviewed for correctness and compatibility with the final version of the base case under development
- Complete NERC category B and C contingency file updates that correspond to the updated network model (Include any contingencies which may not change the powerflow model, but change contingency definitions)
- Maximum credible disturbance (NERC Category D) contingencies
- Any other significant changes such as new load or block load additions
- Support, if necessary, for the development of network models for additional years and demand levels for both near term (years 1 through 5) and longer term (beyond 5 years) analyses.
- Verification that all baseline, network and supplemental upgrades are included in the updated case along with a written description of any case modifications.
- Notification of any changes to tie lines whether they are ties internal to PJM or to external companies.

### Generation Owner Requirements:

- Specific information regarding generator capability per MOD 10 and MOD 12

## **H.1.2 Load Flow Modeling Requirements**

In addition to the guidelines set forth by NERC and the ERAG MMWG procedural manual, PJM uses several specific procedures in establishing the base case so that it represents the best starting point for the annual RTEP analysis.

### Generator step-up transformers

Generator models should represent the physical plant lay-out to the extent possible, explicitly modeling generator step-up transformers (GSUs) and Station Service loads (aka Auxiliary loads). This applies to units above 20 MW and connected to the BES system, consistent with BES requirements. Plants consisting of multiple units aggregating to 75 MW or more also require explicit representation of GSUs and station service loads.

### Interchange

The PJM net interchange in the summer peak case is determined by the firm interchanges that are represented in the PJM OASIS system. The interchange in light load cases follows the light load criteria as defined in the Light Load Reliability Analysis in section 2.3.10 of this manual.

### Generator Reactive Capability

Annually, PJM updates the model for the generator reactive capability (GCAP) of each generator based on data used by PJM Operations, which includes default limits obtained from the most up to date d-curves as well as data provided by the Generator Owners.

### Interconnection Projects With Interconnection Service Agreements (ISAs)

PJM includes queue projects with a signed ISA into the base case as well as verifying the accuracy of queue projects that have not yet signed an ISA. PJM also includes the interconnection, ratings and associated upgrades for each of these projects. Transmission Owners will verify the accuracy of the points of interconnection and the associated upgrades in their zones.

### Real and Reactive Load

Each TO is responsible for modeling the active (real) and reactive load profile in its zone. PJM will scale the load in each zone to the targeted values reported in the latest annual PJM load forecast report.

Real loads will be scaled uniformly in each zone to meet the PJM 50/50 load forecast less any Demand Response (DR), Energy Efficiency (EE), or Behind the Meter (BTM) generation as necessary. Real loads will also be scaled uniformly within each zone for off-peak analysis. Reactive load in each area will be scaled at a constant power factor along with the real load for peak load analysis. For off-peak analysis including light-load, PJM will provide a case to the Transmission Owners, at their discretion, for updating their zonal reactive load profile.

Any deviation from the above method of load modeling method, associated with specific test procedures such as the PJM Load Deliverability Procedure or the PJM Light Load Reliability Test Procedure will be defined specifically in other sections of this manual.

PJM will coordinate with TOs on an individual basis to ensure that non-conforming loads are properly modeled and not uniformly scaled.

### Voltage Schedules

The setting of voltage schedules is crucial to the robustness of cases. PJM allows Transmission Owners to supply generator voltage schedule data. If the data is not provided PJM will use the default voltage schedules as defined in PJM Manual 03.

## **H.1.3 Submittal of Load Flow Data**

### Acceptable Data Formats

- For PSS/E users, cases should be submitted to PJM in a “.SAV” format in a PSS/E version that is readable by the current version of PSS/E that MMWG is using.
- For users of PSLF or other modeling software, cases shall be submitted to PJM in a “.RAW” format that is PSS/E compatible and is readable by the current version of PSS/E that MMWG is using.
- PJM’s migration of PSS/E versions may slightly lag MMWG, in that case it is acceptable to provide updates formatted for the current version that PJM is using.
- TO’s can submit data in an agreed to version if they are unable to export to the latest MMWG compatible version.

### Timing

Transmission Owners must comply with the schedule dictating the timeliness of the case creation process which will be included in the initial email sent to kick off the process. This schedule will include a minimum of 4 weeks to provide updates to the case and corresponding files for the first iteration, and 2 weeks for the second iteration.

### Load Flow Data Quality

- In the event that data provided by Transmission Owners does not pass all of the testing included in the MMWG data checker, PJM may request updated data.
- Transmission Owners must provide unique bus names or circuit ID’s for each winding of all transformers.
- Bus numbers must be within the allocated bus number range for each company.
- Conventions used for the naming of Machine ID’s vary for different TO zones. PJM will coordinate with each TO individually to align with their preferred convention.

- Certain specific modeling and naming conventions which must be followed by all TO's include:
  - High/Low Pressure units should be modeled on the same bus and designated with the corresponding machine ID "H" and "L".
  - No other machine ID should be named "H" or "L".
  - With the exception of High/Low Pressure units, multiple machines modeled on the same bus must have the same status. Offline machines should not be modeled on the same bus as machines which have a status of online.
  - Machines at the same plant with different statuses should be modeled on separate busses connected by a very low impedance line ( $X=.002$ ) as defined in the MMWG manual.

#### **H.1.4 Short Circuit Analysis Models**

Short Circuit data procedures are documented in the Attachment G.7 of this manual, which references ANSI/IEEE 551. The intended use of this attachment is to supplement these procedures and outline the data requirements which PJM follows in creating the short circuit cases used for analysis.

- Short circuit models should be provided in Aspen ".olr" format, if possible.
- Each TO provided Aspen ".OLR" case should model only the TO area and its tie lines. No outside areas should be included in the submission.
- All area numbers in the TO provided cases should be consistent with MMWG designated area numbering convention. Area numbers such as 1, 2, 3, etc. are not acceptable.
- Generation owners must submit to PJM all their breaker data for breakers rated above 100 kV.
- Transmission Owners must submit an excel sheet containing explanations for outaged and out-of-service equipment that is normally in-service.

#### Timing

In the 1st quarter of each year, PJM will send the Transmission Owners an initial current year +5 impedance network model. This case is based on the most up to date PJM short circuit case combined with the previous year's RTEP case containing all upgrades, MTX projects, and generation queue projects in the Facility Studies Phase that have been identified during that RTEP cycle.

In the 4th quarter of each year, PJM will send the Transmission Owners an initial current year +1 impedance network model. This case is based on the most up to date PJM short circuit case combined with the previous year's RTEP case containing all upgrades, MTX projects, and generation queue projects in the Facility Studies Phase that have been identified during that RTEP cycle.

Transmission Owners must comply with the time schedule of the case creation process which will be included in the initial email sent to kick off the process. This schedule will include a minimum of 4 weeks to provide updates to the case and corresponding files. Once

all cases and corresponding files have been submitted to PJM, a +1 case is created and analysis performed to determine overdutied breakers. TOs are then given another 4 weeks to confirm any new overdutied breakers. After the +1 year short circuit case is finalized, the +1 year case is then used to create the +5 year short circuit case for performing the short circuit studies and identifying the new system issues. The identified issues will be sent out to the Transmission Owners who will have 4 weeks to provide solutions to address these issues.

### **H.1.5 Stability Analysis Models**

The case used for stability and dynamic studies is developed by PJM based on information from the Regional Transmission Expansion Plan (RTEP) case prepared by PJM Interconnection and the MMWG case prepared by Powertech Labs for the Eastern Interconnection Reliability Assessment Group (ERAG).

When preparing the base case for stability and dynamics, the ERAG case provides the information for the areas outside PJM while the RTEP case provides the PJM information (e.g. load forecast, network configuration). When combining the ERAG and the RTEP cases, care should be taken to preserve the ties between the PJM areas and the rest of the Eastern Interconnection.

All generator projects active in the PJM queue process that have been studied must be included in the base case for stability and dynamics. In some instances, the RTEP model for the queue project may not be detailed enough for use in stability studies. In this situation, the case must be updated to make sure that all detailed components associated with this project are included in the stability and dynamics power flow model (e.g. generator step-up transformer, loads).

In addition to updating the power flow case with the latest network information, the dynamic models must also be updated to reflect the changes introduced by the RTEP case and the stability and dynamic studies performed by PJM. In this regard, the dynamic data file from the ERAG MMWG case is updated so that the dynamic models for the generators in the PJM areas are matched against the new power flow information from the RTEP. The dynamic model for each queue generator must also be added to the dynamic data file.

The resulting power flow case, the dynamic data file and supporting files required for a complete stability and dynamics base case need also to be correlated and reviewed to determine inconsistencies as well as missing or questionable data. A base case is considered to be finished when, after the review, it compiles, links the models to the PSS/E main structure and initializes correctly. An acceptable condition for a finished base case is when simulated system dynamics, using this case, do not deviate from the initial conditions for any simulation setup with no disturbances applied to the system.

#### **Timing**

In the first quarter of each year, PJM will build stability cases based on the latest RTEP power flow model and the latest ERAG dynamic cases. In this period, PJM will request the Transmission Owners for load models for dynamic studies, and for other supporting data if necessary. Transmission Owners must comply with the time schedule of the stability case creation process which will be included in the initial email sent to kick off the process.

### Stability and dynamics base cases:

Stability is assessed using a summer peak load and a light load condition. The summer peak stability case has the load profile of the RTEP summer peak case and corresponds to the demand expected to be served in the specific planning year. The light load stability case represents 50% of the summer peak load and is developed by scaling down the summer peak load case at the same power factor.

For simplicity, it is recommended to first build the summer peak case and then update that case to reflect the second load condition (light load). This approach provides two cases that are common in bus numbers and network information. Updates to both cases, such as addition or removal of proposed lines or queue projects would be easy to handle due to the uniformity.

After the power flow case has been finalized and revised, the dynamic data file from the dynamic data file will be updated to reflect the changes that were introduced by the addition of the PJM areas from the RTEP case and generation interconnection studies. It is important to note that the RTEP case and the ERAG case complement each other. RTEP case information is used for future generation queue projects and transmission upgrades which don't exist in the ERAG case and ERAG case consists of information of existing units.

The light load case (50% peak) is derived from the summer peak case. This approach ensures consistent bus numbers and network information in both cases, making addition or removal of proposed lines or queue projects easy to handle. After the summer peak case is completed, the PJM load is scaled down to a load representing 50% of the 50/50 load. The areas outside PJM are updated with the light load case from the corresponding ERAG MMWG case. Note that generation and shunt capacitors may be turned off or disabled in order to achieve convergence of the power flow. In addition, all pumped storage hydro units are modeled in the pumping mode with their governors and power systems stabilizers deactivated or adjusted to reflect the appropriate operating condition.

### Generation/Transmission Owner Responsibilities:

- Provide necessary supporting data for stability case build upon PJM's request including but not limited to: topology information and dynamic modeling and station loads
- Provide station loads, including power factors and load representation data (CONL file) if the load representation is different from the one in the ERAG MMWG series
- Verify upgrades and generator modeling (MVA base & Topology)

If there is any discrepancy between the RTEP case and the ERAG MMWG case for existing units, PJM will follow up with the Generation owner with assistance from the TO to insure that the most current data is used.

A complete base case (summer peak or light load) must include at least:

- A power flow file: This file contains the network information and provides the initial conditions for the dynamic models.
- A dynamic data file: This file contains all the information necessary to simulate the dynamic response of the various system components.

- A gnet file: This file contains the information of those generators that do not have a dynamic model. Any generator listed in this file is considered as a negative MVA load.
- A conl file: This file indicates how loads will be modeled based on a combination of constant MVA, constant current and constant admittance. It is strongly recommended that each TO develop more accurate load representation for stability and dynamics studies

#### Dynamics Data Submittal Requirements and Guidelines:

The Multiregional Modeling Working Group (MMWG) provides the following topics pertaining to dynamics data submittal requirements and guidelines. This information is accessible in Appendix II of the MMWG Procedure Manual V5. A hyperlink to the manual is located at the bottom of this section.

- Power Flow Modeling Requirements
  - Bus name identifiers for synchronous condensers, Static VAR Compensators (SVCs) modeled as generators, switched shunts, relays, and HVDC terminals.
  - Step-up transformer representation requirements for both MMWG power flow cases and non-MMWG power flow cases.
  - Resistance and reactance data placements for step-up transformers represented in the power flow generator data records.
  - Xsource value representations in the power flow generator data record.
  - SVC representation requirements in power flows.
- Dynamic Modeling Requirements
  - Synchronous generator and condenser modeling / associated data requirements and exceptions.
  - Additional representation requirements and exceptions for synchronous generators and condensers modeled as described in Requirement II.1.
  - PSS/E modeling requirements for any other types of generating units and dynamic devices.
  - Exceptions to the use of standard PSS/E dynamic models.
  - Required written documentation and its submittal procedures for user-defined modeling in MMWG cases.
  - Generating unit, synchronous condenser, and other dynamic device requirements for netting.
  - Lumping conditions of similar or identical generating units at a plant.
  - Location requirements for per unit data.
  - Exception procedure for any requirements listed.

- Dynamics Data Validation Requirements
  - Dynamics data screening requirements
  - Preliminary procedures to undergo before regional data submittal to the MMWG coordinator.
  - Material required by each region to validate the dynamics model.
- Guidelines
  - Additional documentation that should be submitted with dynamics data.
  - Information pertaining to parameters for representing loads via the PTI PSS/E CONL activity that the regions should provide to the MMWG.

Location of MMWG Procedural Manual:

<https://rfirst.org/reliability/easterninterconnectionreliabilityassessmentgroup/mmwg/Documents/>

**Revision History****Revision 20 (12/22/2011):**

- Added additional detail to the NERC Category C3 “N-1-1” section
- Created NERC Category C3 “N-1-1” stability section
- Added references to DUKE Energy Ohio/Kentucky
- Added additional detail to the NERC Standard PRC-023 Transmission Relay Loadability Section
- Updated Section 2 to reflect 24 Month Planning Process
- Fixed two small typos in the alt paragraph on P55 in the C.3 Section

**Revision 19 (09/15/2011):**

- Added Attachment H Power System Modeling Data

**Revision 18 (7/20/2011):**

- Added Light Load Reliability Analysis criteria and created a new attachment D-2 to contain the criteria.
- Added description of reactive load modeling in CETL base cases.

**Revision 17 (4/13/2011):**

- Added references where appropriate to reflect the inclusion of the American Transmission Systems, Inc. (ATSI) and Cleveland Public Power (CPP).
- Clarified the methodology to establish an IROL in the Planning Horizon.
- Updated the short circuit methodology to include the existing process to study all BES breakers.

**Revision 16 (11/18/2010):**

- Added a Contingency Definitions section (10/20/2010 MRC approval)
- Added Appendix G.10 NERC Standard PRC-023 – Transmission Relay Loadability (10/20/2010 MRC approval)
- Modified PJM Critical Energy Infrastructure Information Release Guidelines (08/05/2010 MRC approval)
- Added clarifying language to Baseline Voltage Analysis test methodology (08/05/2010 MRC approval) Updated the IROL definition to align with the latest NERC IROL definition (08/05/2010 MRC approval)

**Revision 15 (04/21/2010):**

- Added new Attachment F describing PJM stability, short circuit and special RTEP practices and procedures. This Attachment includes the special requirements for coordination of planning for nuclear interfaces

**Revision 14 (02/01/2010):**

- Attachment C: Added language to specify how energy efficiency is incorporated into deliverability tests. Added additional language to specify the load level modeled in the load deliverability test for the area being tested. (1/22/10 MRC Approval)

**Revision 13 (11/16/2009):**

- Inserted Commercial Probability technique in Attachment C, Generator Deliverability Procedure Step 5 (10/2/08 MRC approval)
- Added Attachment F: Determination of System Operating Limits for Planning the Bulk Electric System (06/17/09 MRC approval)
- Attachment C: Cap on generation delivery adders (12/21/09 MRC approval)
- Attachment C: Added language to Overview of Deliverability to Load to clarify criteria that may trigger analysis of potential new LDAs (11/11/09 MRC approval)
- Updated hyperlinks throughout the manual
- Temperature correction and clarification to Attachment B Section VII.N.

**Revision 12 (08/08/2008)**

The following revisions primarily consist of additions, clarifications and reorganization to address FERC Order No. 890 requirements:

- Additions to Section 1 to update, clarify, and expand the RTEP overview.
- Combine old Sections 6 and 2 into an expanded Section 2.
- Move wind, power factor and behind the meter generation material to a reconstituted Section 6
- Include additional reliability planning process and criteria information
- Market Efficiency Process revisions (section 2 and Attachment E) plus additional editorial and consistency changes throughout including Attachments D, E, and G.
- Added Exhibit 1 edits to Intro, Sections 1, 2, related attachments
- Multiple passes of CEII revisions.
- Generation Delivery clarifications in Attachment C.
- Removed the final material in Section 2 that is related to Interconnections to Manual 14A and revised the remaining material appropriately for Manual 14B.
- Exhibit 1 update for quarterly queues
- Attachment D criteria clarifications

- Added final RPPWG comments of Nov 30, 2007 meeting, added minor clarifications, and cut material to move to the appropriate generation or transmission interconnection related portions of revised 14A and 14E as to be determined. Sections deleted from here and moved to either 14A or 14E are: (the following attachment designations are according to the previous version Manual 14B lettering)
- Moved Section 3: Generator and Transmission Interconnection Planning Process
  - Generation and Transmission Interconnection Feasibility Study
  - System Impact study
  - Generation and Transmission Interconnection Facilities Study
- Moved Section 4: Small Resource Interconnection Process
- Moved Section 5: Interconnection Service, Construction & Other Service Agreements
- Moved Section 6: Additional Generator Requirements
  - Behind The Meter Generation Projects
  - Generator Power Factor Requirements
  - Wind-Powered Generation Projects
- Moved Attachment A: PJM Generation and Transmission Interconnection Planning Process Flow
- Attachment B: PJM Cost Allocation Procedures
- Moved PART 1: PJM GENERATION AND TRANSMISSION INTERCONNECTION COST ALLOCATION
- Moved Attachment C : PJM Generation and Transmission Interconnection Planning Team Role Diagram
- Moved Attachment F: General Description of Facilities Study Procedure
- Moved Attachment H: Small Generator (10 MW and Below) Technical Requirements and Standard
- Moved Attachment H-1: Small Generator (above 10 MW to 20 MW) Technical Requirements and Standards
- Moved Annex 1: SCADA Requirements by Transmission Owner Region

**Revision 11 (10/05/2007)**

The Manual Title has been changed. The RTEP process has evolved over the past 5+ years and so has the scope of Manual 14B. The title of the manual has been changed from "Generation and Transmission Interconnection Planning" to "PJM Regional Planning Process"

Section 6 and Attachment I have been revised to reflect the implementation of the 15-year horizon component of PJM's Regional Planning Process cycle, including that for market efficiency. These changes are made in accordance with the mmm, dd 2006 FERC approval of PJM's subject Operating Agreement and Open Access Transmission Tariff (OATT) revisions.

Conforming editorial revisions have been made throughout the remainder of the document.

### ***Revision 10 (03/01/2007)***

- Attachment B: Regional Transmission Expansion Plan revised to include steps for reactive planning in the RTEP.
- Revised hyperlinks in Attachment D: PJM Reliability Planning Criteria.
- Attachment H: Small Generator (10 MW and Below) Technical Requirements and Standards replaces former attachment on Small Generators of 2 MW and less.
- Attachment H-1: Small Generator (above 10 MW to 20 MW) Technical Requirements and Standards added.
- References to PJM OATT provisions in Sections 2 and 5 are revised to indicate that they are now in the new Part VI of the OATT (along with their former Part IV locations)
- Wording in Section 2 under "Summary of RTEPProcess" and again in Attachment E is revised to reflect that generation retirements included in project studies will be those announced as of the date a project enters the project queue.
- Introduction trimmed to eliminate redundant information.
- List of PJM Manuals exhibit removed, with directions given to PJM Web site where all the manuals can be found.
- Revision History permanently moved to the end of the manual.

### ***Revision 09 (06/07/06)***

Manual sections 1 and 2 and Attachment B (Regional Transmission Expansion Plan – Scope and Procedure) are revised to include Probability Risk Analysis (PRA) of Aging Infrastructure as an input to the PJM Region transmission planning process. The timeline in Section 5 is revised to require the Transmission Owner to submit a final invoice to PJM within 120 days after project completion. Attachment B (Regional Transmission Expansion Plan – Scope and Procedure) is also revised to add guidelines for Scenario Planning. Replaced references throughout to "ECAR, MAAC and MAIN" with ReliabilityFirst, the new replacement regional reliability council as of January 1, 2006.

Revisions were made on the following pages: 8, 10, 12 through 16, 23, 24, 41, 56, 62, 63, 65, 67, 68 and 98.

**Revision 08 (01/16/06)**

Section 1 is revised to state that all analyses of Transmission System adequacy are conducted using the load forecast produced annually by PJM. Attachments E and G are revised to state that load is modeled in the RTEP base case used for the Generator Deliverability procedure at a “non-diversified” 50/50 summer peak load level as per the latest load forecast.

**Revision 07 (01/04/06)**

Section 2 is revised to add process for “Evaluation of Operational Performance Issues.” Attachment A is revised to clarify the Load Flow Cost Allocation Method and to add the Schedule 12 Cost Allocation process. Attachment C is revised to include references to Dominion and to add Addendum 2 “Common Mode Outage Procedure” to the Generator Deliverability Procedure. Attachment D is revised to include a minimum power factor for system “load”.

**Revision 06 (11/21/05)**

Section 2 is revised to indicate that “One RTEP baseline regional plan will be developed and approved each year” and that “Generation retirements will not affect the study results” for any project that has received an Impact Study Report. Attachment B is revised to clarify and expand the scope and procedure of the Regional Transmission Expansion Planning Process.

**Revision 05 (06/23/05)**

Revision includes a change in Section 6 to include reference to new Attachment E, re-writes of Attachment C (**PJM Deliverability Testing Methods**) and Attachment D (**PJM Reliability Planning Criteria**) and the addition of new Attachment E (**Economic Planning Process, Congestion Relief Evaluation**).

**Revision 04 (12/17/04)**

Revision includes the changes in Sections 2 and 4 necessitated for compliance with FERC Order 2003 for standardized Generator Interconnection Agreements and Procedures, re-write of Attachment F: Facilities Study Guidelines, re-write of Attachment D: PJM Reliability Planning Criteria, and the addition of Attachment H: Small Generator (2MW or less) Technical Requirements and Standards.

**Revision 03 (06/08/04)**

Revision includes the addition of rules for Generator Power Factor Requirements and Behind the Meter Generation in Section 2, the designation of small resources as 20 MW or less in Section 4, the addition of the Economic Planning Process in Section 6 and general updates.

**Revision 02 (10/31/03)**

Revision includes the addition of Wind-Powered Generator Specific Requirements to Section 2, a placeholder for the addition of the Economic Planning Process in new Section 6 (currently under development) and the addition of Attachments D (**Regional Transmission Expansion Plan – Scope and Procedure**), E (**PJM Deliverability Testing Methods**), F

(**General Description of Facilities Study Procedure**) and G (**PJM Reliability Planning Criteria**); also, text changes throughout to conform with Nuclear Plant Licensee Final Safety Analysis Report grid requirements and with new Manual M-14E (**Merchant Transmission Specific Requirements** – also currently under development).

***Revision 01 (02/26/03)***

Revision includes a manual title change from PJM Manual for **Generation Interconnection Transmission Planning (M-14B)** to PJM Manual for **Generation and Transmission Interconnection Planning (M-14B)**; also, text changes throughout to conform to new Manuals M-14C and M-14D.

***Revision 00 (12/18/02)***

This document is the initial release of the PJM Manual for **Generation Interconnection Transmission Planning (M-14B)**.

Manual M-14, Revision 01 (03/03/01) has been restructured to create five new manuals:

M-14A: “Generation Interconnection Process Overview”

M-14B: “Generation Interconnection Transmission Planning”

M-14C: “Generation Interconnection Facility Construction”

M-14D: “Generation Operational Requirements”

M-14E: “Merchant Transmission Specific Requirements”