

PJM Generator Interconnection Request

Feasibility / Impact Study Report

**Queue #Q13
Kankakee 12kV
1.6 MW**

September 2006

Updated 6/9/10

Q13 Kankakee 12kV Feasibility / Impact Study Report

General

Q13 Kankakee 12kV is a WM Illinois Renewable Energy, LLC 1.6 MW request for Capacity Interconnection Rights for existing generation located at 180 E. 6000 South Road in Chebanse, Kankakee County, IL. Q13, referred to as the “Kankakee Project” in this report, is presently connected to the ComEd distribution system and operating as a jurisdictional QF under the name of Kankakee County Recycling and Disposal Facility. Q13 consists of two 800kW engine - generators fueled by landfill gas (methane). The facility has been in operation for more than 10 years.

Direct Connection

The Kankakee project is presently connected to the ComEd distribution system via the 12.5 kV feeder K5781 at the Kankakee TSS157 Substation.

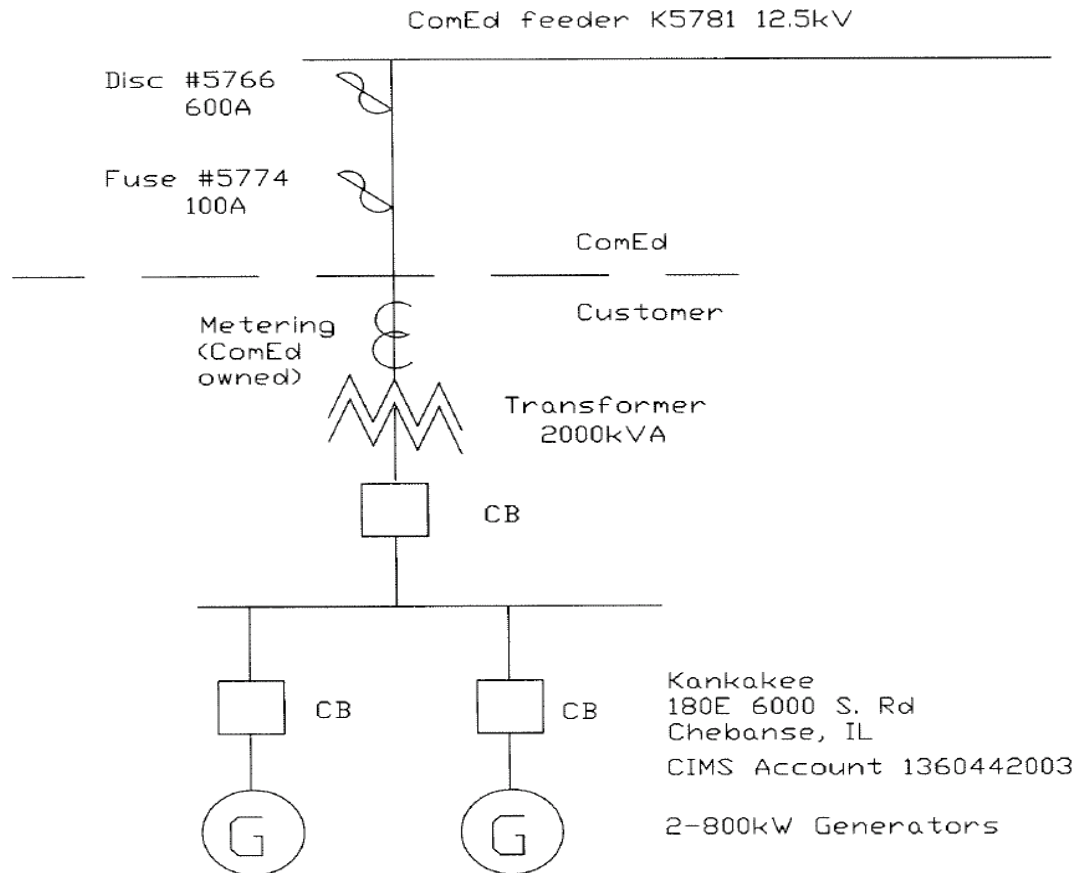

PJM has studied this project for impacts to the transmission system (see below).

Scope of Metering Work

The Kankakee Project assumes responsibility for all costs of design and construction of all Communication, Telemetry, SCADA, and Metering per the ComEd and PJM requirements below.

Revenue Metering and SCADA Requirements

For PJM: Interconnection Customer will be required to install equipment necessary to provide Revenue Metering (KWH, KVARH) and real time data (KW, KVAR) for Interconnection Customer’s generating Resource. See PJM Manuals M-01 and M-14D, and PJM Tariff Sections 24.1 and 24.2.

For ComEd: Interconnection Customer will be required to install equipment necessary to provide bi-directional Revenue Metering (KWH, KVARH) and real time data (KW, KVAR, circuit breaker status, and 12 kV voltage) for Interconnection Customer’s generating Resource. See ComEd Applicable Standards available on the PJM website – “Exelon Energy Delivery Interconnection Guidelines Generators Less than 2 MVA”. An RTU needs to be installed per ComEd standards.

http://www.exeloncorp.com/ourcompanies/comed/comedbiz/energy_rates/our_rates_and_prices.htm

ComEd’s Cost to Install the Required Metering

The total Order of Magnitude estimated cost for ComEd’s installation is **\$101,600**. The lead-time required for installation of the metering is approximately 12 months.

Project Name: Q13			
Developer: Waste Management			
Station:Kankakee Project			
Item Description	Material	Labor	Total
Telemetry and SCADA	\$ 24,400	\$ 36,600	\$ 61,000
Metering	\$ 1,000	\$ 1,600	\$ 2,600
Engineering and Engineering review		\$ 20,000	\$ 20,000
Field testing and modification review		\$ 18,000	\$ 18,000
Metering contract requires \$50/month maint.			\$ -
Customer to supply dedicated phone line.			\$ -
Material Subtotal	\$ 25,400		
Labor Subtotal		\$ 76,200	
Total			\$ 101,600

Loss Factor Charge:

For this project, Q13, the Loss Factor was calculated to be 1.17%. Therefore under current ComEd system configuration there would be charges applied to this generator for distribution losses. The Loss Factor is subject to periodic update as system configuration change in the future.

Notes:

1. Optional Kankakee Project scope of work: Interconnection Customer may choose to design, procure and install bi-directional revenue metering and SCADA compatible with ComEd requirements. The design, procurement and installation would be subject to approval by ComEd.
2. Kankakee Project is required to provide the required class A phone lines for metering and communication requirements. Communication to be continuously monitored by SCADA.
3. Should the Kankakee Project choose to communicate all the required data to PJM via the internet, arrangement must be made to assure that PJM will transmit such data to ComEd according to existing protocol.

Network Impacts

The #Q13 project was studied as an injection of 1.6 MW (Capacity) into the Kankakee TSS 137 substation. Project #Q13 was evaluated for compliance with PJM reliability criteria for summer peak conditions in 2011. If the Kankakee Project increases the capability of the plant to greater than 1.6 MW then the customer (Waste Management Corporation) must re-enter the PJM Queue for re-evaluation. Potential network impacts were as follows:

Generator Deliverability

No problems were identified.

Multiple Facility Contingency

No problems were identified.

Contribution to Previously Identified Overloads

None

Short Circuit

No problem identified.

New System Reinforcements

None identified.

#Q13 – Kankakee 12kV
Generation Interconnection

This analysis was completed to assess the reliability impact for a new generator interconnecting to the PJM System as a Capacity Resource.

Network Impacts

The #Q13 project was studied as an injection of 1.6 MW (Capacity) into the Kankakee TSS 137 substation. Project #Q13 was evaluated for compliance with PJM reliability criteria for summer peak conditions in 2011. Potential network impacts were as follows:

Generator Deliverability

No problems were identified.

Multiple Facility Contingency

No problems were identified.

Contribution to Previously Identified Overloads

None

Short Circuit

No problem identified.

New System Reinforcements

None identified.