

***PJM Generator Interconnection
T12 Kent - Harrington 4 MW
Feasibility / Impact Study***

August 2007
DMS# 433337

General

Queue T12 is an AMERESCO request for 4 MW Capacity Interconnection Rights for generation already connected as an Energy-only Resource (See previous Queue N16). T12 generation consists of four (4) 1057 KW Diesel / Landfill Gas engine-generators installed at the Central Landfill, Route 10, Sandtown, Delaware and is interconnected to DEC (Delaware Electric Cooperative) Vaughn substation Feeder 53. Three generators are presently connected, one generator is planned for future interconnection. Project T12 Capacity (3 MW) is already available for commercial operation.

Direct Connection Requirements

Project T12 is connected to DEC's Vaughn substation Feeder 53 as shown on the one line diagram below. There are no additional Direct Connection requirements.

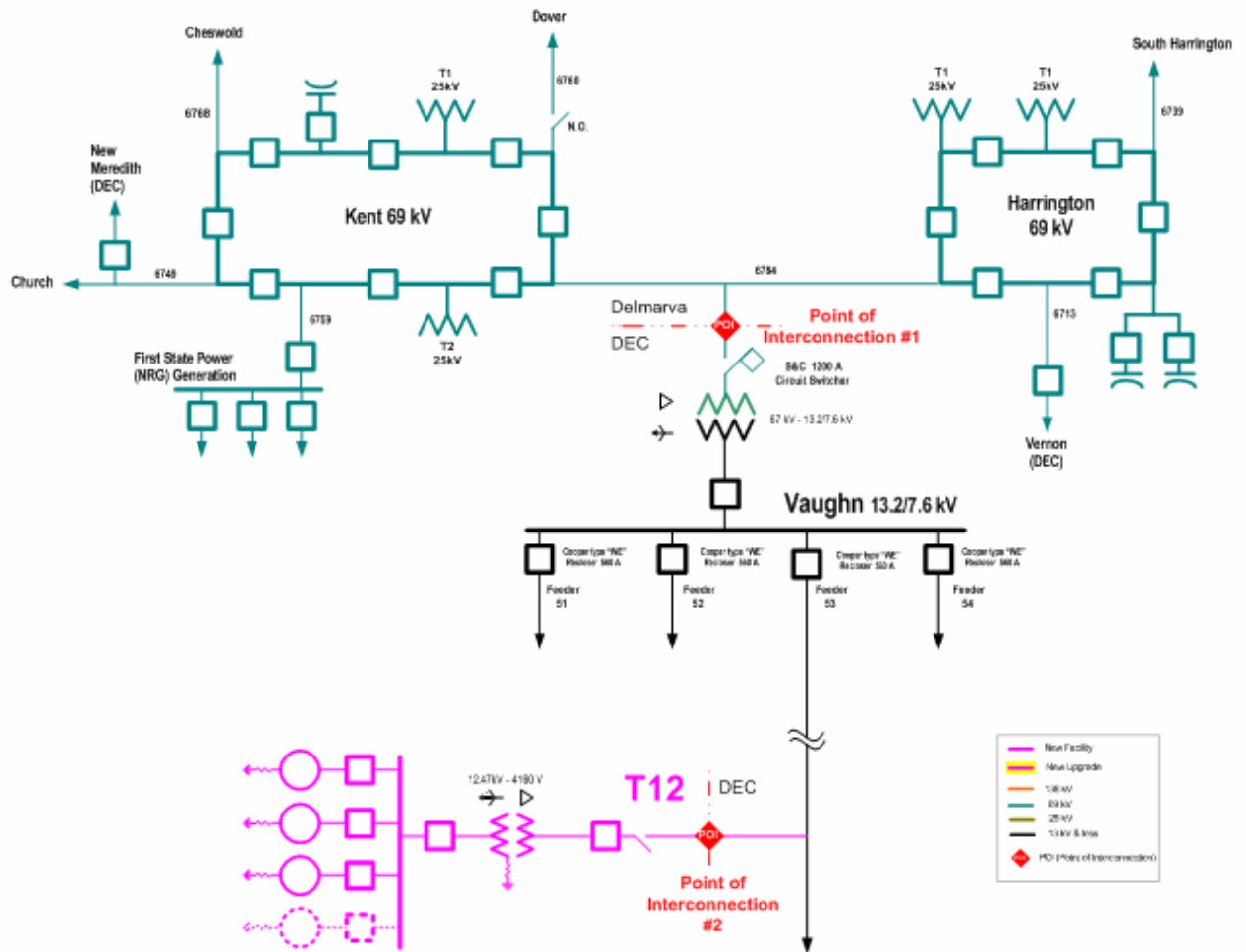

Interconnection Customer Scope of Work

No additional work is required.

DEC (Delaware Electric Cooperative) Scope of Work

No additional work is required.

Delmarva Scope of Work

No additional work is required.

Network Impacts

The Queue T12 project was studied as a 4 MW Capacity injection into the Kent – Harrington 69 kV line at the interconnection point to D.E.C.’s Vaughn substation. The project was evaluated for compliance with reliability criteria for summer peak conditions in 2012. Potential network impacts were as follows:

Local System Impacts (Normal system conditions with all facilities in service)

No Problems were identified

Generator Deliverability

(Single or N-1 contingencies for the Capacity portion only of the interconnection)

No Problems were identified

Multiple Facility Contingency

(Double Circuit Tower Line contingencies only for the full energy output. Stuck breaker and bus fault contingencies will be performed for the Impact Study)

No Problems were identified

Contribution to Previously Identified Overloads

(This project contributes to the following contingency overloads, i.e. “Network Impacts”, identified for earlier generation or transmission interconnection projects in the PJM Queue)

No problems were identified

Short Circuit

No problems identified.

Stability Analysis

Not required for generating stations less than 30 MW.

New System Reinforcements

(Upgrades required to mitigate reliability criteria violations, i.e. “Network Impacts”, initially caused by the addition of this project generation)

None

Contribution to Previously Identified System Reinforcements

(Overloads initially caused by prior Queue positions with additional contribution to overloading by this project. This project may have a % allocation cost responsibility which will be calculated and reported for the Impact Study)

None