

***PJM Generator Interconnection  
V3-051 Letort 3.2 MW  
Feasibility / Impact Study***

**December 2009**

Docs #570552

## General

Queue V3-051 is a PPL Renewable Energy, LLC request to interconnect a 3.2 MW energy / 0.4 MW capacity generating resource consisting of two 1.6 MW wind turbine generators to be located at Turkey Hill Dairy in Manor Township, near Conestoga City, Pennsylvania. Frey Farms is an existing 3.2 MW gas generator for the same Interconnection Customer and located approximately 1,000 feet away from the proposed location of the proposed generation for Turkey Hill Dairy. Letort 69-12 kV substation is the closest substation to the generation located near grid 36524s23159. V3-051 has requested an in-service date of October 1, 2010. **This study does not imply a PPL EU commitment to this in-service date.**

This study assumes that the proposed generation will only be allowed to operate when the distribution system is in a normal operating arrangement. Queue V3-051 has not requested an alternative outlet for the generation.

## Direct Connection

Queue V3-051 can interconnect to the existing 12kV Letort #36-01 line as shown on the one line diagram below.

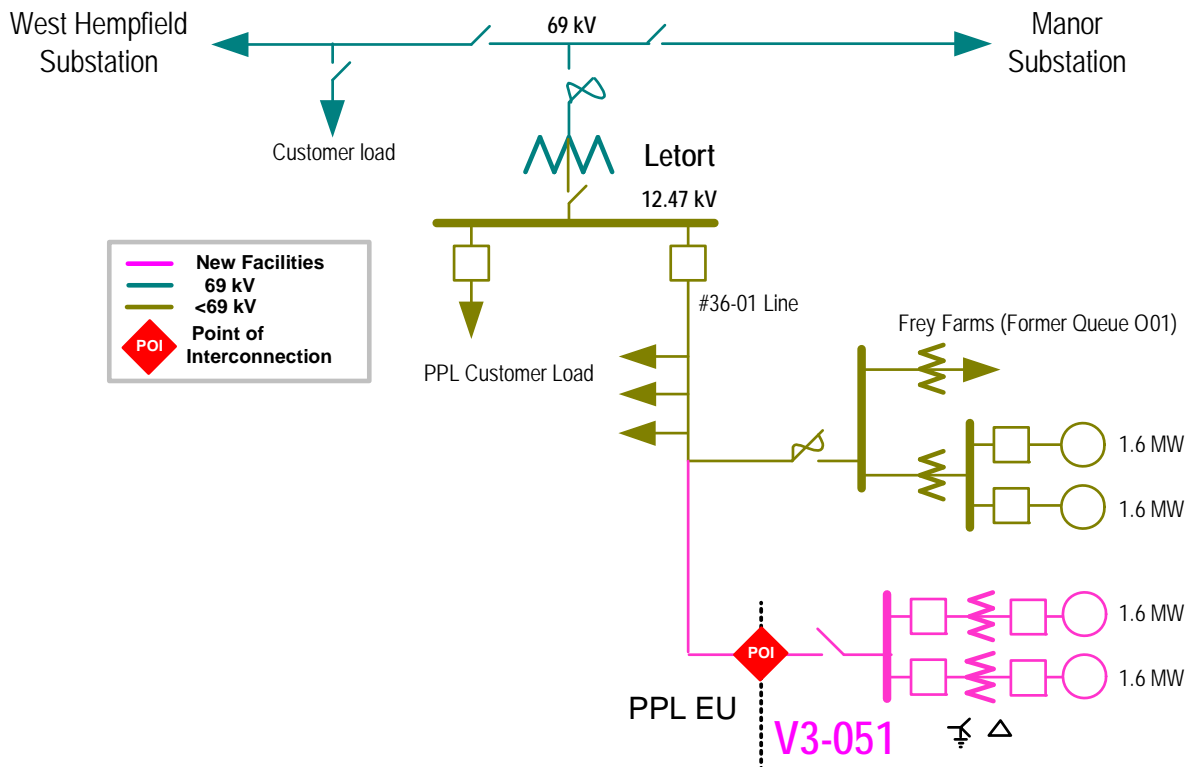

## **Interconnection Customer Scope of Direct Connection Work**

Queue V3-051 Interconnection Customer will be responsible for the construction of all generating station facilities on the V3-051 side of the POI (Point of Interconnection) as shown on the one line diagram of the previous page.

### **Protection equipment --**

The Interconnection Customer will need to install suitable protection and control equipment based on PPL EU parallel generation requirements. This includes both Intertie Protective Relaying (IPR) and Point of Contact (POC) relaying. Please refer to the PPL EU web site for the IPR and POC requirements. The website addresses are shown below:

IPR Requirements:

<http://www.pplelectric.com/Business+Partners/Tools+and+Reference+Center/Customer-Owned+Generation/>

PPL EU's preference for IPR is the Beckwith M-3520 relay package. Note that failure of the single microprocessor-based relay will disable the protection. For that reason PPL EU requests that a backup relay be installed. The alternative would be to disconnect the generation in the event that the single relay is out of service. A suitable choice for backup are the ABB DPU 2000R or SEL 351 packages.

POC Requirements:

[http://www.pplelectric.com/NR/rdonlyres/B0937C7E-B6E9-40AD-AE8C-ED3C9558E528/0/point\\_of\\_contact.pdf](http://www.pplelectric.com/NR/rdonlyres/B0937C7E-B6E9-40AD-AE8C-ED3C9558E528/0/point_of_contact.pdf)

### **DTT Relaying Requirements--**

Direct Transfer Trip (DTT) protection will be required for both the proposed Queue V3-051 interconnection and the existing O01 generation. Queues V3-051 / O01 generation will be tripped from West Hempfield and Manor 230-69 kV substations for opening of the West Hempfield – Manor 69 kV breakers at either substation, and from the Letort 69-12 kV substation for opening of line #36-01 breaker. The existing Queue O01 DTT protection scheme can be modified in order to meet the new requirements. Refer to figure on page 7.

Queue V3-051 Interconnection Customer will be required to install telephone line based Direct Transfer Trip equipment (matching PPL Electric Utilities equipment) to both the PPL EU Manor and the PPL EU West Hempfield substations. This will require two separate telephone lines.

Suitable protection for the above phone lines, based on IEEE 487-2000.

An additional fiber optic link from the new Queue V3-051 facility to the existing Queue O01 facility will eliminate the need to duplicate all of the DTT communication links.

### **SCADA Requirements--**

PPL EU will require the installation of a PPL EU approved SCADA equipment that will connect to its existing SCADA system. PPL Electric Utilities will supply suitable drawings and a material list for the generator to provide this equipment. The current PPL Electric Utilities design uses commercially available PLC equipment, with the software provided by PPL Electric Utilities.

### **Metering Equipment Installation at the Point of Interconnection--**

Installation of revenue grade Metering Equipment will be required at the Queue V3-051 Point of Interconnection (POI). PPL EU will design and supply the required metering equipment but all the installation cost would be borne by the developer. All metering equipment must meet applicable PPL EU tariff requirements as well as being compliant with all applicable requirements of the PJM agreements. The equipment should be housed in a control cabinet or similar enclosure and must be accessible to PPL EU metering personnel.

### **Isolation Breaker Requirement --**

V3-051 Interconnection Customer will have its own isolation breaker. This breaker can be located on either the high or low side of the Interconnection Customer's transformer. This device will NOT be used to synchronize or parallel operating generation to the PPL EU system.

### **Transmission Owner (PPL EU) Scope of Direct Connection Work**

Queue V3-051 can be interconnected to the existing Letort 12kV line #36-01. The following requirements were determined with consideration of the existing 3.2 MW generation for Frey Farms also interconnected to the Letort 12kV line #36-01. Refer to the one line diagram on the previous page.

To accommodate the interconnection of V3-051, substation work at two PPL EU-owned regional substations (West Hempfield and Manor) and one PPL EU-owned area supply substation (Letort) is required. **The total estimated cost is \$560,000.**

Direct Transfer Trip (DTT) protection will be required from West Hempfield 230-69 kV, Manor 230-69 kV, and Letort 69-12 kV for both V3-051 and the existing O01 generation. The existing O01 DTT protection scheme can be modified in order to meet the new requirements. PPL EU proposes the following DTT communication scheme which will allow use of the existing equipment and minimize the need for new equipment. The following relay and control upgrades at PPL EU facilities will be required in order to accommodate the generation interconnection with the proposed DTT communication scheme:

### **Regional Transmission Substation Work (\$500,000)**

Due to low customer loading on the West Hempfield – Manor 69 kV network line, it is possible for the generation to form an island with load on the 69 kV transmission circuit. Therefore Direct Transfer Trip (DTT) protection to the regional 69 kV source substations (West Hempfield and Manor) is required. The work at both West Hempfield and Manor 230/69 kV substation yards include:

- Installation of DTT (Direct Transfer Trip) equipment,
- Installation of associated wiring, cables, conduit, etc.

This work includes installation of phone based DTT equipment and control design modifications at both West Hempfield and Manor 230/69 kV substations which will communicate to two matching sets of DTT equipment at the customer's site. The scheme will provide a trip signal to both V3-051 and O01 for any 69 kV line fault, or any other condition that will causes both PPL EU breaker at West Hempfield and Manor substation to open. This will trip BOTH the existing Queue O01 generation and the proposed V3-051 generation for the loss of BOTH 69 kV sources.

### **Distribution Work (estimated \$60,000)**

The \$60,000 cost estimate includes relay and control modifications at Letort Substation and the line extension to Queue V3-051. The existing radio based DTT scheme will be retained but modified to use currently spare channels for status and for the new Queue V3-051 generator interconnection, and any other additional signals as required. Upgrades at Letort Substation are required to detect a local island condition for loss of 69 kV source to Letort Substation (e.g. operation of the 69 kV fuses).

In addition to the telephone-based and radio-based DTT protection scheme as described above, the following upgrades to the existing DTT scheme will be required. Note the costs associated with DTT equipment at the Queue V3-051 facility are NOT included in this estimate. The V3-051 Interconnection Customer will be required to install a new fiber optic-based link between the existing Queue O01 (Frey Farms) and the new Queue V3-015 site at Turkey Hill Dairy. This will pass the DTT signals between the two generating sites without the need to duplicate all of the DTT signals and equipment back to Letort, West Hempfield, and Manor.

### **Voltage Regulation Requirements**

In order to maintain acceptable voltage regulation to the 12kV system, the generator must be operated below 0.98 leading PF, absorbing Vars. As required by the PJM tariff, the developer shall design its facility to maintain a composite power factor delivery at continuous rated power output at the point of interconnection at a power factor of at least 0.95 leading (absorbing VARs) to 0.95 lagging (supplying VARs). In order to eliminate significant voltage deviation, preliminary PPL EU studies indicate that the V3-051 IPP facility will need to operate slightly leading (MW out; MVAR in), measured at the interconnection point. Further, the operation of the existing IPP O01 will be modified to absorb vars as required.

### **Direct Connection Timing**

In order to engineer and complete the above modifications under normal working conditions, PPL will require **9 months** from the time that the ISA agreement is executed and PPL receives authorization to proceed from PJM. Consequently, the requested in service date is in jeopardy. Please see "Remarks" at the end of the *Direct Connection* section for additional information.

In order to meet the requested in service date of October 1<sup>st</sup>, 2010, the following must be completed as soon as possible:

**Queue V3-051 must sign the ISA and PJM must authorize PPL to proceed with actual engineering and physical construction by the first week in January, 2010. The ISA must be signed by this deadline to meet the October 1, 2010 in service date**

Queue V3-051 must accept the increased cost obligation of funding engineering and construction overtime to meet a compressed work schedule. The estimated overtime amount could be 150% of the above-identified cost.

The V3-051 Interconnection Customer must provide engineering drawings to PPL EU for final review and recommendations prior to construction.

The telephone cable and related telephone infrastructure at V3-051's high voltage site must meet modern IEEE 487 standards. For existing facilities, this may require that existing telephone circuits have the same high voltage protection installed or upgraded.

V3-051 must contact the local telephone company High Voltage Protection Group to begin the engineering review and to initiate the process for establishing service at V3-051's high voltage facility. The lead time to establish phone service at high voltage sites may be 3-4 months or longer. Be aware that the DTT (PRDA type telephones lines) are NOT a tariff service, therefore you may experience difficulty in obtaining this service, and we will attempt to help when this arises. V3-051 should secure the required phone lines as soon as possible for the telephone based DTT protection scheme to West Hempfield and Manor regional substations.

The figure below illustrates the proposed DTT communication paths.

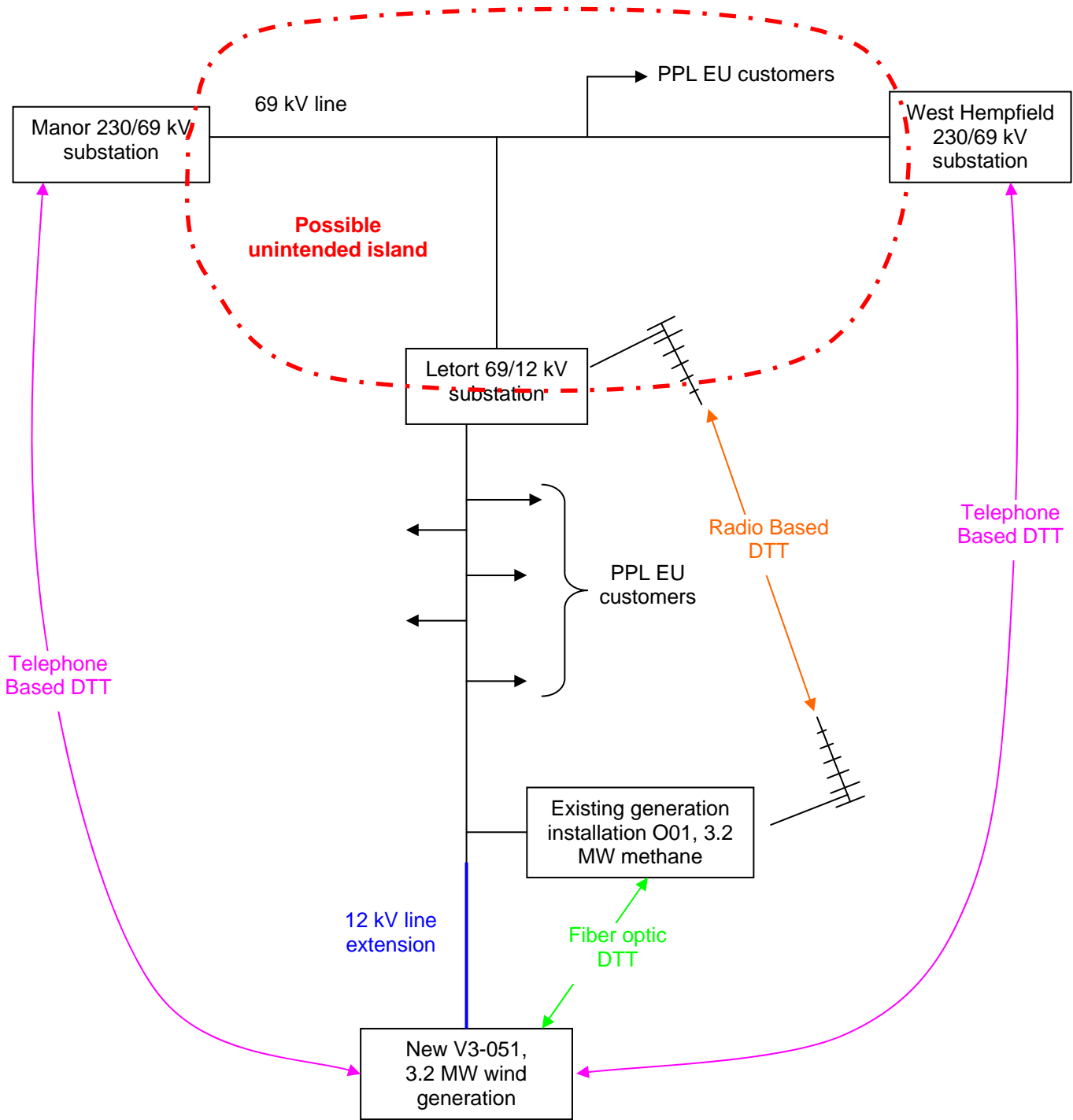

## ***Network Impacts***

The Queue V3-051 project was studied as a 3.2 MW energy (0.4 MW Capacity) injection into the 12 kV Letort line# 39-01. The project was evaluated for compliance with reliability criteria for summer peak conditions in 2014. Potential network impacts were as follows:

### **NETWORK IMPACTS**

#### **Generator Deliverability**

*(Normal System, Single or N-1 contingencies for the Capacity portion only of the interconnection)*

No problems identified.

#### **Multiple Facility Contingencies**

*(Double Circuit Tower Line, Stuck Breaker and Bus Fault contingencies for the full energy output)*

No problems identified

#### **Contribution to Previously Identified Overloads**

*(This project contributes greater than the PJM cost allocation threshold loading to the following contingency overloads, i.e. "Network Impacts", identified for earlier generation or transmission interconnection projects in the PJM Queue)*

No problems identified

#### **Stability Analysis**

Not required because of size and location of proposed generation.

#### **Short Circuit**

No problems identified.

### **NETWORK UPGRADE REQUIREMENTS**

#### **New System Reinforcements**

*(Upgrades required to mitigate reliability criteria violations, i.e. "Network Impacts", initially caused by the addition of this project generation)*

None required.

#### **Contribution to Previously Identified System Reinforcements**

*(Overloads initially caused by prior Queue positions with additional contribution to overloading by this project. This project will have a % allocation cost responsibility)*

None required.