



Wind Farm Communication Model Strawman

Objective: Provide a dependable real-time solution to manage wind in real-time, ensuring:

1. accurate outage data, which is essential for an accurate wind power forecast
2. Prompt wind reduction, which typically would occur as a last resort just prior to emergency procedures.

Note: This communication model may be expanded to include other renewable resources as PJM develops forecast tools or their penetration levels increase.

Issue: The current operating experience communicating with wind farms has been very challenging. Often, PJM is required to communicate verbally with Market Operations Centers, Generator Operators, or offtakers who have to relay communications to the wind farm operator who are in charge of the wind turbine control systems or have the detailed information with respect to turbine outages. This issue is further compounded if Wind Farms are permitted to operate in real-time as separately owned, multiple segments off a jointly owned generator feed line behind one point of interconnection. To reduce the occurrences of manual dispatch, PJM has incorporated the unique nature of the wind farm dispatch within the PJM Unit Dispatch System (UDS). The PJM UDS recognizes that wind generation can be reduced for economics/constraint control but is dependent upon wind speed to increase output. The UDS algorithm handles curtailment as follows:

1. Generation redispatch is cost-effective (\$/MW effect) for congestion. Highest \$/MW effect will be reduced first. **Currently wind offers are generally negative (\$/MW) Therefore, it is anticipated that reduction of these resources is expected to be last resort.**
2. Generation is reduced economically under non-constrained conditions. Since wind bid is typically zero or negative, it should be the last resource to reduce. Once all generation is economic min, emergency procedures are required.

PJM is working with wind farm owner/operators on an individual basis to process the UDS basepoint., The effectiveness of this initiative will be limited if the UDS basepoint for a single wind farm must be sent to multiple Generator Owner/Operators, that do not have the ability to process the basepoints via wind farm control systems¹. Sending separate basepoints in of itself does not limit PJM's effectiveness. Effectiveness is limited by PJM having to call entities that do not have the ability to change the output of the turbines during a reliability event and who must in turn call the true operator of the units to change output.

Manual dispatch directives to multiple wind owners will delay controlling actions resulting in less efficient market operations and a potential adverse impact to system reliability. Manual dispatch to a subset of owners at a common wind farm may result in



customers questioning curtailments and in the need to develop additional administrative procedures to ensure fair/equitable reductions to an aggregate plant on a rotating basis.

Considering wind power is likely to be the last resort controlling action prior to emergency operations, efficient communication is essential to ensure continued reliable operations consistent with NERC Standards².

Given the needs and concerns stated above, PJM proposes to communicate dispatch instructions through the one entity that has "operational control"³ of the turbines and to provide UDS signal(s) to the control system of that entity. PJM will also provide the UDS signal(s) to the individual offtakers.

Summary: PJM Operations requires one direct operational contact for all operational phases of the wind farm (generator operator). This requirement will also apply to a wind farm when the initial Generation Owner seeks to assign a portion(s) of the wind farm to another entity(ies). The generator operator will be the primary interface with PJM on behalf of the wind farm. In that role, the generator operator will be responsible for: (i) responding to PJM Dispatch directions (especially during the time of curtailment or emergencies) and (ii) reporting of wind turbine availability to support the PJM wind forecasting tool.



PJM Preferred Solution: PJM Operations would prefer a model similar to Keystone/Conemaugh where there is a single Generator Operator (GOP) responsible for the entire wind farm operations. Having a single GOP would align with the NERC Functional Model registry as the registered GOP⁴. The single GOP would be responsible for all day-ahead and real-time bidding into PJM Systems (eMkt), real-time communications with PJM Dispatch, as well as providing accurate turbine outage information within eDart, which is a key component in developing an accurate wind power forecast⁵. The wind farm GOP is required to provide PJM with aggregate turbine outage information via eDart to satisfy the requirements of NERC TOP-002-2a. Settlements can be allocated by PJM based on ownership shares. In summary, PJM proposes the following:

1. Wind farms will have a single GOP
2. The wind farm will have the ability to process a UDS basepoint directly by the wind farm control systems or through a single GOP.
3. Settlements will be based upon ownership share of the wind farm.

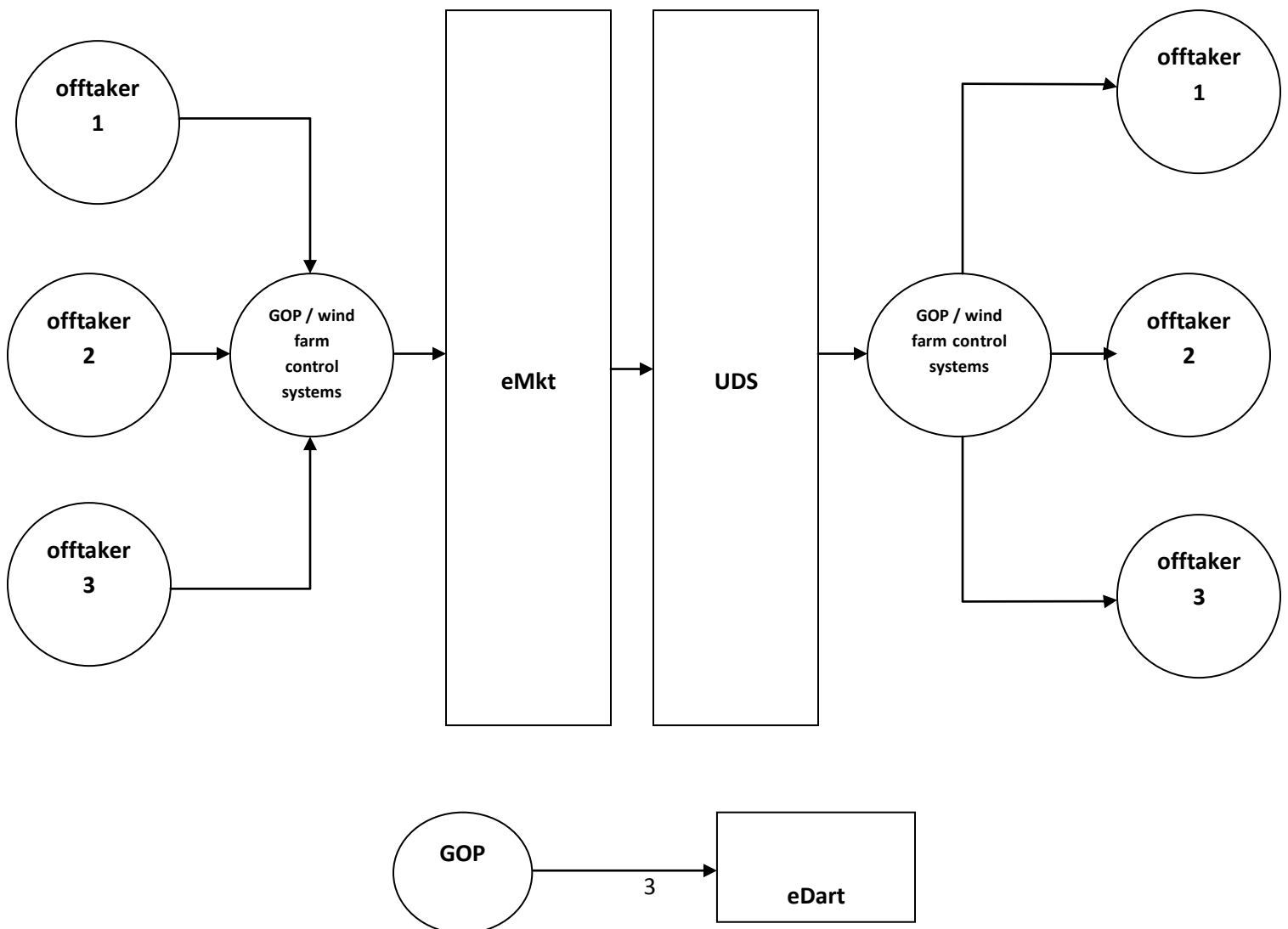



Alternate Solution: The alternate solution would still require a single Generator Operator (GOP), however, each owner/off taker would still be able to interact with eMkt, providing day-ahead bids and hourly updates. The single GOP would be responsible for all real-time communications, including providing accurate turbine outage information within eDart. UDS would send individual UDS basepoints to each owner/off taker as well as sending to the GOP. The GOP would be responsible to respond to UDS basepoints. Settlements will model individual owner/offtakers. In summary, the alternate solution proposes the following:

1. Market systems (eMkt, eRPM, others?) will be maintained by individual owner/offtakers (PJM market participants).
2. Wind farms will have an identified GOP. The GOP is responsible for:
 - a. responsible for eDart application
 - b. all real-time communications with PJM
 - c. dispatch instructions and processing UDS basepoint(s) directly in the applicable turbine control systems
3. Settlements will be based on the applicable PJM market model. This preserves market participant's rights and will allow multiple "market units" to be maintained and receive individual basepoints.

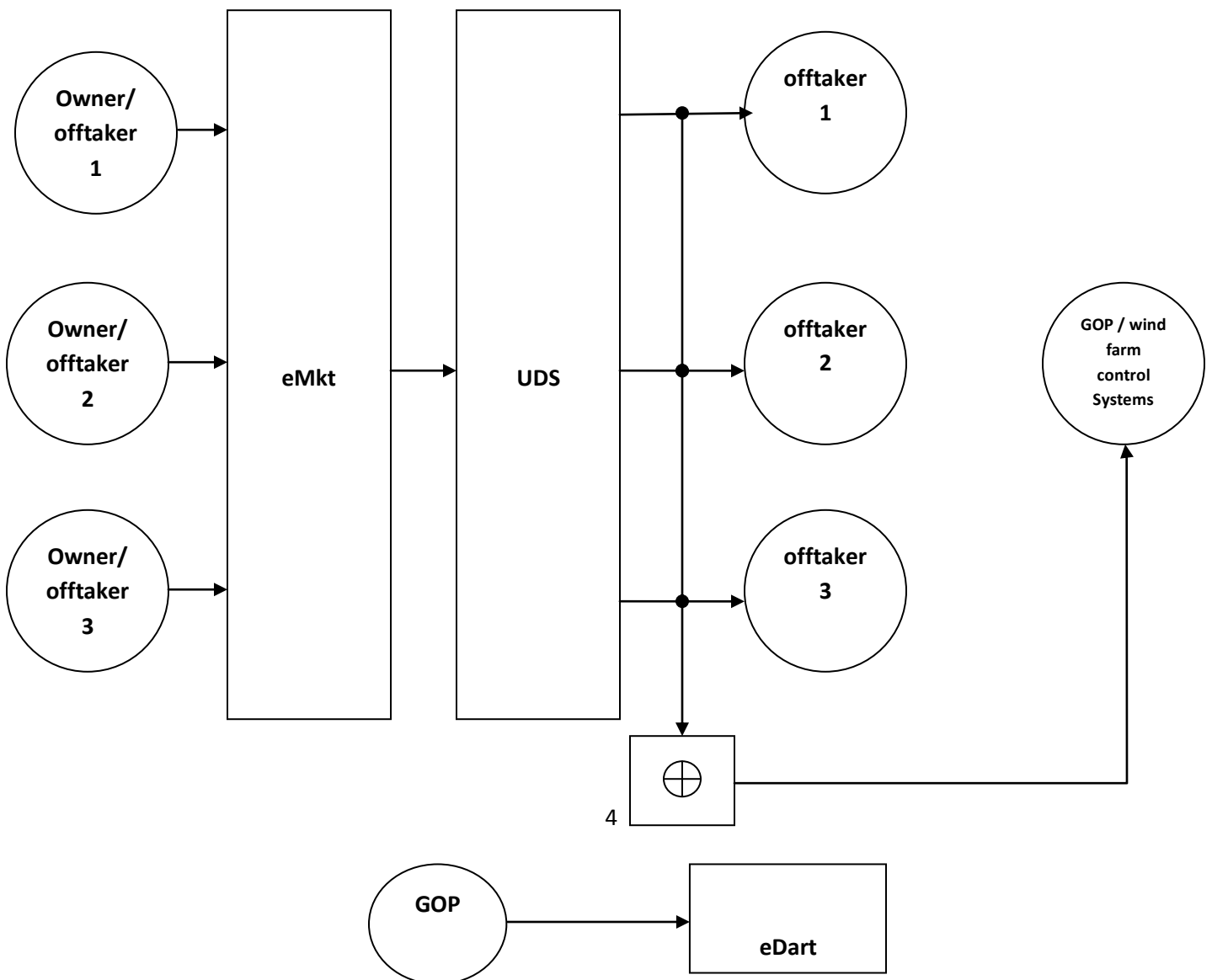



Footnote 1: PJM Manual requirements

MANUAL 14D, ATTACHMENT B (PAGE 73) SECTION 8 REQUIREMENTS:

Note 4: Wind Farm Curtailment should be achieved within 15 minutes or within a timeframe that the wind farm technology permits. PJM should be notified if curtailment is expected to exceed 15 minutes.

FOOTNOTE 2: APPLICABLE NERC STANDARDS (RELEVANT SECTIONS HIGHLIGHTED)

COM-002-2

R1. Each Transmission Operator, Balancing Authority, and **Generator Operator** shall have communications (voice and data links) with appropriate Reliability Coordinators, Balancing Authorities and Transmission Operators. Such communications shall be **staffed and available for addressing a real-time emergency condition.**

M1. Each Transmission Operator, Balancing Authority and Generator Operator shall have Communication facilities (voice and data links) with appropriate Reliability Coordinators, Balancing Authorities, and Transmission Operators and shall have and provide as evidence, a list of communication facilities or other equivalent evidence that confirms that the **communications have been provided to address a real-time emergency condition.** (Requirement 1, part 1)

IRO-001-1

R8. Transmission Operators, Balancing Authorities, Generator Operators, Transmission Service Providers, Load-Serving Entities, and Purchasing-Selling Entities shall comply with Reliability Coordinator directives unless such actions would violate safety, equipment or regulatory or statutory requirements. Under these circumstances, the Transmission Operator, Balancing Authority, **Generator Operator**, Transmission Service Provider, Load-Serving Entity, or Purchasing-Selling Entity **shall immediately inform the Reliability Coordinator of the inability to perform the directive so that the Reliability Coordinator may implement alternate remedial actions.**

M7. Each Transmission Operator, Balancing Authority, Generator Operator, Transmission Service Provider, Load-Serving Entity, or Purchasing-Selling Entity shall have and provide upon request evidence that could include, but is not limited to, operator logs, voice recordings or transcripts of voice recordings, or other equivalent evidence that will be used to confirm that it did comply with the Reliability Coordinator's directives, or if for safety, equipment, regulatory or statutory requirements it could not comply, it informed the Reliability Coordinator immediately. (Requirement 8)

Footnote 3: Operational Control



Operational control as used in this sentence is meant to identify the entity that operates the control system (SCADA, EMS, GMS, etc) which communicates with, and sends control signals to, the turbines.

FOOTNOTE 4: NERC FUNCTIONAL MODEL (RELEVANT SECTIONS HIGHLIGHTED)

Generator Operation

Definition

Operates generating unit(s) to provide real and reactive power.

Tasks

1. Formulate daily generation plan.
- 2. Report operating and availability status of units and related equipment, such as automatic voltage regulators.**
3. Develop annual maintenance plan for generating units and perform the day-to-day generator maintenance.
4. Operate generators to provide real and reactive power or reliability-related services per contracts or arrangements.
5. Monitor the status of facilities classed as generating assets.
6. Support Interconnection frequency.

Responsible Entity — Generator Operator

Relationships with Other Responsible Entities

Ahead of Time

- 1. Provides generation commitment plans to the Balancing Authority.**
2. Provides Balancing Authority and Transmission Operators with requested amount of reliability-related services.
- 3. Provides operating and availability status of generating units to Balancing Authority and Transmission Operators for reliability analysis.**
4. Reports annual maintenance plan for generating units to Reliability Coordinator, Balancing Authority and Transmission Operators.
5. Reports status of automatic voltage regulators to Transmission Operators.
6. Provides operational data to Reliability Coordinator.
- 7. Revises generation maintenance plans per directive of Reliability Coordinator.**
8. Receives reliability analyses from Reliability Coordinator.
9. Receives notice from Purchasing-Selling Entity if Interchange Transaction approved or denied.
10. Receives reliability alerts from Reliability Coordinator.



11. Receives notification of transmission system problems from Transmission Operators.

Real Time

12. Provides real-time operating information to the Transmission Operators and the required Balancing Authority.

13. Adjusts real and reactive power as directed by the Balancing Authority and Transmission Operators.

Function — Generator Ownership

Definition

Owns and provides for maintenance of generating facilities.

Tasks

1. Establish generating facilities ratings, limits, and operating requirements.
2. Design and authorize maintenance of generation plant protective relaying systems, protective relaying systems on the transmission lines connecting the generation plant to the transmission system, and Special Protection Systems.
3. Authorize maintenance of owned facilities classified as generating assets.
4. Provide verified generating facility performance characteristics / data.

FOOTNOTE 5: OUTAGE REPORTING REQUIREMENTS

TOP-002-2a

R15. Generation Operators shall, at the request of the Balancing Authority or Transmission Operator, provide a forecast of expected real power output to assist in operations planning (e.g., a seven-day forecast of real output).

M8. Each Generator Operator shall have and provide upon request evidence that could include, but is not limited to, voice recordings or transcripts of voice recordings, electronic communications, or other equivalent evidence that will be used to confirm that, on request, it **provided a forecast of expected real power output** to assist in operations planning. (Requirement 15)