



Working to Perfect the Flow of Energy

PJM Manual 14D:
Generator Operational
Requirements

Revision: ~~2019~~

Effective Date: ~~October 1, 2010~~

Prepared by
Power System Coordination
Department

© PJM 2010



PJM Manual 14D:

Generator Operational Requirements

Table of Contents

Table of Contents ii

Table of Exhibits [vii](#)

Approval 7

Current Revision 7

Introduction 8

 ABOUT PJM MANUALS 8

 ABOUT THIS MANUAL 8

Intended Audience 8

References 9

 USING THIS MANUAL 9

What You Will Find In This Manual 9

Section 1: Generator Markets and Operations 11

 1.1 GENERATOR INTERCONNECTION PROCESS: MARKETS AND OPERATIONS PHASE 11

 1.2 GENERATOR COMMERCIAL NAMING CONVENTION 13

Section 2: Responsibilities of Generation Owners 14

 2.1 GENERATOR OWNERS' RESPONSIBILITIES 14

Section 3: Control Center Requirements 17

 3.1 PJM CONTROL CENTER CATEGORIES FOR GENERATING ENTITIES 17

 3.2 CONTROL CENTER REQUIREMENTS FOR GENERATING ENTITIES 17

 3.2.1 *Computer System Requirements* 18

 3.2.2 *Communications Requirements* 18

 3.2.3 *Facilities Requirements* 18

 3.2.4 *Control Center Staffing Requirements* 18

 3.3 VOICE COMMUNICATION REQUIREMENTS FOR GENERATING ENTITIES 19

 3.3.1 *Dispatch Voice and Facsimile Communications* 19

 3.3.2 *Alternative Voice Communications* 19

Section 4: Data Exchange and Metering Requirements 20

 4.1 COMPUTER SYSTEM DATA EXCHANGE 20

 4.1.1 *PJMnet Communications System* 20

 4.1.2 *Energy Management System (EMS)* 20

 4.1.3 *PJM EMS Communication Protocols* 20

 4.1.4 *EMS Data Exchange* 21

 4.1.5 *EMS Model* 22

 4.1.6 *SCADA—Supervisory Control and Data Acquisition* 23

 4.2 DATA MANAGEMENT AND METERING REQUIREMENTS 28

 4.2.1 *Data Management and Security* 28

 4.2.2 *Metering Plan* 29

 4.2.3 *Metering for Individual Generators* 30

Section 5: Participation in PJM Markets 32

 5.1 MARKETING OPTIONS 32



- 5.1.1 PJM Wholesale Energy Market 32
- 5.1.2 Regulation Market 33
- 5.1.3 Synchronized Reserve Market 33
- 5.1.4 Capacity Credit Market 34
- 5.2 ANCILLARY SERVICES 34
 - 5.2.1 Reactive Supply and Voltage Control from Generating Sources Service 34
 - 5.2.2 Regulation and Frequency Response Service 34
- 5.3 MARKETING TOOLS 35
 - 5.3.1 eMKT 35
 - 5.3.2 Markets Database 35
 - 5.3.3 PJM eSchedules 35
 - 5.3.4 PJM eCapacity 35
 - 5.3.5 eDART 35
 - 5.3.6 eGADS 36
- 5.4 DESCRIPTION OF THE TWO-SETTLEMENT SYSTEM 36
 - 5.4.1 Market Participants 36
 - 5.4.2 The Day-Ahead Market 37
 - 5.4.3 The Real-Time Balancing Market 38
 - 5.4.4 Grid Accounting 38
- 5.5 PRE-SCHEDULING AND SCHEDULING 40
- 5.6 UNIT COMMITMENT 40
 - 5.6.1 Process 40
 - 5.6.2 Data Requirements 41
- Section 6: Pre-Operational Requirements 42**
 - 6.1 DATA EXCHANGE TESTING 42
 - 6.1.1 Introduction 42
 - 6.1.2 Test Requirements for New Generator Management Systems (GMS) 42
 - 6.1.3 Communications Considerations 43
 - 6.1.4 Offline Test 43
 - 6.1.5 Online Test 45
 - 6.1.6 Dispatcher Testing Procedure and Computer-to-Computer Testing 45
 - 6.2 TRAINING AND SYSTEM OPERATOR CERTIFICATION 46
 - 6.2.1 Training 46
 - 6.2.2 PJM System Operator Certification 46
 - 6.3 COORDINATION WITH DISPATCH 47
 - 6.3.1 Operation 47
 - 6.3.2 Communication 47
 - 6.3.3 Test Energy 48
 - 6.3.4 Other Requirements 48
- Section 7: Generator Operations 50**
 - 7.1 DISPATCHING OF GENERATION 50
 - 7.1.1 Generator Real-Power Control 50
 - 7.1.2 Voltage and Reactive Control 50
 - 7.1.3 Generator Operation under Constrained System Conditions 52
 - 7.1.4 Generator Operation under Emergency Operating Conditions 52
 - 7.1.5 Black Start 55
 - 7.2 SWITCHING REQUIREMENTS 56
 - 7.3 CRITICAL INFORMATION AND REPORTING REQUIREMENTS 56
 - 7.3.1 Planned Outage 56
 - 7.3.2 Maintenance Outage 57
 - 7.3.3 Unplanned Outage 57
 - 7.3.4 Generating Unit Reactive Capability Reporting 58
 - 7.3.5 Fuel Limitation Reporting 59



7.4 SYNCHRONIZATION AND DISCONNECTION PROCEDURES 62

Section 8: Wind Farms Requirements 63

8.1 COMPUTER SYSTEM DATA EXCHANGE 63

8.2 WIND FARM DATA REQUIREMENT FOR WIND POWER FORECASTING 64

 8.2.1 Initial Data Requirements 64

 8.2.2 Aggregate Real Time Output 64

 8.2.3 Real Time Meteorological Tower (or mutually agreed upon alternative source) 64

 8.2.4 Generator Outage Reporting (Aggregate Turbine availability) 65

 8.2.5 Grid Capacity Limit (Constraints or Economic Curtailments) 65

 8.2.6 Wind Power Forecast 65

8.3 FORECAST DATA USAGE 66

 8.3.1 Real-time Reliability Assessment 66

 8.3.2 Day-ahead Reliability Assessment 66

Section 9: Generator Deactivations 67

9.1 GENERATOR DEACTIVATION PROCESS 67

 9.1.1 Generator Deactivation Request 67

 9.1.2 Initial Analysis 67

 9.1.3 Analysis Results 68

9.2 COMPENSATION TO GENERATORS REQUESTED TO REMAIN IN SERVICE FOR RELIABILITY 69

Section 10: Black Start Replacement Process 71

10.1 BLACK START REPLACEMENT PROCESS 71

 10.1.1 Initial Black Start Commitment 71

 10.1.2 Replacement Process Step 1 71

 10.1.3 Replacement Process Step 2 72

 10.1.4 Replacement Process Step 3 72

 10.1.5 Replacement Process Step 4 72

 10.1.6 Replacement Process Step 5 74

10.2 COST-BASED COMPONENTS FOR BLACK START REPLACEMENT 76

 10.2.1 Capital Cost Components 76

 10.2.2 Avoidable Cost Definition 76

 10.2.3 Variable Cost Components 77

Section 11: Generator Data Confidentiality Procedures 78

11.1 GENERATOR DATA CONFIDENTIALITY PROCEDURES 78

 11.1.1 Generator Data within a Transmission Owner's Zone 78

 11.1.2 Generator Data outside a Transmission Owner's Zone 78

 11.1.3 Process to Authorize Release of Real-Time Generation Data 79

 11.1.4 Process to Authorize Release of Scheduled Generation Outage Data 80

 11.1.5 Executing a Data Confidentiality Agreement 80

 11.1.6 PJM Evaluation of Data Request 81

 11.1.7 Dispute Resolution 81

Attachment A: New Generator Checklist 82

**Attachment B: New PJMnet Customer Implementation Voice/Data Communications
Template 85**

 OBJECTIVE 85

Attachment C: New PJM Customer Voice/All Call Communications Request Form 90

 OBJECTIVE 90

**Attachment D: PJM Generating Unit Reactive Capability Curve Specification and
Reporting Procedures 9493**



Attachment E: PJM Generator Reactive Capability Testing	9897
OBJECTIVE.....	9897
GENERAL REQUIREMENTS.....	9897
TESTING REQUIREMENTS FOR BOTH UNITS LARGER THAN 70 MW AND BLACK START UNITS.....	9998
NOTIFICATION AND REPORTING REQUIREMENTS.....	10099
<i>Test Cancellation</i>	103402
<i>Voltage Schedules</i>	103402
EXIT STRATEGY.....	103402
<i>Risk</i>	103402
<i>Requirements</i>	103402
<i>Parameters</i>	104103
POST-TEST EVALUATION.....	104103
<i>Test Evaluation</i>	104103
<i>Units Testing Within 5% of Stated Limits</i>	104103
<i>Units Testing Over 5% of Stated Limits</i>	104103
<i>Units Testing Below 5% of Stated Limits</i>	105104
GLOSSARY.....	105404
Attachment F: Generator Reactive Capability Test Study Process	109408
OBJECTIVE.....	109408
<i>Study Process – Example</i>	109408
Attachment G: PJM Generator Markets and Operations Process Flow Diagram	114143
Attachment H: Implementation Team Role Clarity Diagram	115414
Attachment I: Generator Data Confidentiality Agreement	116415
Attachment J: Generator – Data Release Matrix	132434
Attachment K: Template Letter for a Transmission Owner Seeking Generator Data Within its Zone to be Released by PJM	133432
Attachment L: Wind Farm Communication Model	134433
APPENDIX A: Behind the Meter Generation Business Rules	136436
DEFINITION AND PURPOSE OF BEHIND-THE-METER GENERATION (BTMG).....	136436
ELIGIBILITY FOR BTM NETTING.....	136436
BTM NETTING – GENERAL RULES.....	136436
PARTICIPATION IN LOAD MANAGEMENT PROGRAMS.....	138437
GENERATION NETTED AGAINST LOAD.....	138437
BTM NETTING – NON-RETAIL PARTICIPATION.....	139438
BTM ADJUSTMENT PROCESS.....	140439
Revision History	142441



Table of Exhibits

EXHIBIT 1: GENERATOR MARKETS AND OPERATIONS PROCESS FLOW AND TIMELINE 13

EXHIBIT 2: SUMMARY OF EMS DATA REQUIREMENTS AND EXCHANGE RATES 22

EXHIBIT 3: DEADLINES FOR MODELING DATA TO BE SUBMITTED 23

EXHIBIT 4: GUIDELINES FOR METERING INSTALLATIONS..... 25

EXHIBIT 5: EQUIPMENT TYPES FOR DATA EXCHANGE WITH PJM 26

EXHIBIT 6: TYPICAL MULTI-UNIT METERING AND DATA FLOW CONFIGURATION 27

EXHIBIT 7: PJM REAL-TIME AND REVENUE DATA PRECISION REQUIREMENTS 27

EXHIBIT 8: APPLICABLE SERVICES AS DEFINED BY MARKET PARTICIPATION 39

EXHIBIT 9: CRITERIA FOR DETERMINING CAPACITY SHORTAGE EMERGENCY CONDITIONS 54

EXHIBIT 10: CRITERIA FOR DETERMINING LIGHT LOAD EMERGENCY CONDITIONS 55

EXHIBIT 11: SAMPLE DATA (FUEL BASELINE) 60

EXHIBIT 12: GENERATION DEACTIVATION PROCESS FLOW 70

EXHIBIT 13: BLACK START REPLACEMENT PROCESS FLOW DIAGRAM 75

EXHIBIT 14: ANNUAL CAPITAL RECOVERY FACTORS (CULLED FROM DRAFT TARIFF ATTACHMENT
Y ON RELIABILITY PRICING MODEL) 77

EXHIBIT 15: PROCESS TO APPROVE REAL-TIME DATA REQUEST – DECISION POINTS WITH
DEFINITIONS 79

EXHIBIT 16: PROCESS TO APPROVE SCHEDULED OUTAGE DATA REQUEST – DECISION POINTS
WITH DEFINITIONS 80

EXHIBIT 17: NEW GENERATION CHECKLIST PAGE 1 OF 3 82

EXHIBIT 18: NEW GENERATION CHECKLIST PAGE 2 OF 3 83

EXHIBIT 19: NEW GENERATION CHECKLIST PAGE 3 OF 3 84

EXHIBIT 20: PJM UNIT REACTIVE CAPABILITY CURVE DATA FORMAT [9594](#)

EXHIBIT 21: PJM REACTIVE RESERVE CHECK (RRC)..... [9796](#)

EXHIBIT 22: VOLTAGE ACTUALS PRIOR TO TEST [110409](#)

EXHIBIT 23: OPEN-ENDED LINE VOLTAGE SETUP DISPLAY [111440](#)

EXHIBIT 24: VOLTAGE ACTUALS PRIOR TO MITIGATION STEPS [112444](#)

EXHIBIT 25: VOLTAGE ACTUALS AFTER MITIGATION STEPS..... [113442](#)

EXHIBIT 26: PJM GENERATOR MARKETS AND OPERATIONS PROCESS OVERVIEW [114443](#)

EXHIBIT 27: IMPLEMENTATION TEAM ROLE CLARITY DIAGRAM [115444](#)

EXHIBIT 28: WIND FARM COMMUNICATION MODEL 1 [134433](#)

EXHIBIT 29: WIND FARM COMMUNICATION MODEL 2 [135434](#)



Approval

Approval Date: ~~09/15/2010~~

Effective Date: ~~10/01/2010~~

~~David Schweizer, Manager~~

~~Power System Coordination Department~~

Current Revision

~~**Revision 19 (10/01/2010):**~~

~~Incorporated Wind Farm Communication Model as Attachment L.~~



Introduction

Welcome to the ***PJM Manual for Generator Operational Requirements***. In this Introduction you will find information about PJM Manuals in general, an overview of this PJM Manual in particular, and information on how to use this manual.

About PJM Manuals

The PJM Manuals are the instructions, rules, procedures, and guidelines established by PJM for the operation, planning, and accounting requirements of the PJM Balancing Authority and the PJM Energy Market. The manuals are grouped under the following categories:

- Transmission
- PJM Energy Market
- Generation and transmission interconnection
- Reserve
- Accounting and Billing
- PJM administrative services
- Miscellaneous

For a complete list of all PJM Manuals, go to www.pjm.com and select "Manuals" under the "Documents" pull-down menu.

About This Manual

The ***PJM Manual for Generator Operational Requirements*** is one of the PJM procedure manuals. This manual focuses on the generator markets and operations requirements for generating entities to connect to the PJM system and their responsibilities as signatories to the Operating Agreement of PJM Interconnection, L.L.C.

This manual also refers to other PJM manuals, which define in detail the telecommunication protocols, redundancy requirements, accuracy and periodicity of data, generator obligations, reporting requirements, and accounting procedures established to ensure reliable operation.

The ***PJM Manual for Generator Operational Requirements*** consists of 10 sections and 11 attachments (labeled A through K). Both the sections and the attachments are listed in the table of contents beginning on page ii.

In addition, a process flow diagram is included (Attachment G) summarizing the Generator and Markets Operations process and timelines.

Intended Audience

The intended audiences for this PJM Manual for Generator Operational Requirements are:

- Applicants to the Operating Agreement of PJM Interconnection, L.L.C.
- Generation Owners or those interested in siting and building generation in the PJM Balancing Authority.



- Operations planning staff and plant personnel for generating entities
- PJM Members
- PJM staff

References

There are other PJM documents that provide both background and detail on specific topics. These documents are the primary source for specific requirements and implementation details. This manual does not replace any of the information in those reference documents. The references for the **PJM Manual for Generator Operational Requirements** are:

- PJM Manual for **Control Center and Data Exchange Requirements (M-1)**.
- PJM Manual for **Transmission Operations (M-3)**.
- PJM Manual for **Power System Application Data (M-5)**.
- PJM Manual for **Pre-Scheduling Operations (M-10)**.
- PJM Manual for **Scheduling Operations (M-11)**.
- PJM Manual for **Balancing Operations (M-12)**.
- PJM Manual for **Emergency Operations (M-13)**.
- PJM Manual for **Open Access Transmission Tariff Accounting (M-27)**.
- PJM Manual for **Operating Agreement Accounting (M-28)**.
- PJM Manual for **Billing (M-29)**.
- PJM Manual for **Administrative Services for the PJM Interconnection Agreement (M-33)**.
- PJM Manual for **Definitions and Acronyms (M-35)**.
- PJM Manual for **Certification and Training Requirements (M-40)**.

Using This Manual

We believe that explaining concepts is just as important as presenting procedures. This philosophy is reflected in the way we organize the material in this manual. We start each section with the “big picture.” Then we present details, procedures or references to procedures found in other PJM manuals.

What You Will Find In This Manual

- A table of contents that lists two levels of subheadings within each of the sections and attachments
- An approval page that lists the required approvals and a brief outline of the current revision
- Sections containing the specific guidelines, requirements, or procedures including PJM actions and PJM Member actions
- Attachments that include additional supporting documents, forms, or tables



- A section at the end detailing all previous revisions of this PJM Manual



Section 1: Generator Markets and Operations

Welcome to the Generator Markets and Operations section of the **PJM Manual for Generator Operational Requirements**. This section presents the following information:

- A summary of the Markets and Operations phase of the Generator Interconnection Process (see *-Generator Interconnection Process: Markets and Operations Phase*).
- Rules for assigning a commercial plant/unit name to new generation (see *-Generator Commercial Naming Convention*).

1.1 Generator Interconnection Process: Markets and Operations Phase

The Generator Markets and Operations phase is initiated during the Interconnection Service Agreement (ISA) and Construction Service Agreement (CSA) implementation phase of the generator interconnection process. The Interconnection Coordination (IC) Project Manager coordinates the activities of PJM Internal Coordination (Operations Planning, System Operations, CR&T, PJMnet, EMS) and the Generation Owner to complete the Generator Markets and Operations activities during this phase. After the ISA and CSA implementation phase, PJM team leadership is transferred from the IC Project Manager to PJM Customer Relations and Training (see Attachment H for Implementation Team Role Clarity Diagram).

The table below describes PJM Generator Markets and Operations interconnection process flow and timeline (see Attachment G for PJM Markets and Operations Process Flow Diagram).

Activity	Duration		Manual Reference
	Activity	Cumulative	
Activity 1: PJM Interim Capacity Study	(1-10d)		
A. System planning updates new generation project list with current generator in-service date	10 days	10 days	-
Activity 2: EMS Model Update	(11-80d)		
A. PJM Transmission and Interconnection Planning provides modeling information and commercial name for plant & units to System Operations	70 days	80 days	Section 4
B. System Operations submits Model Change requests to Engineering Support for database updates			
C. New database tested & installed on production EMS			



Activity	Duration		Manual Reference
	Activity	Cumulative	
Activity 3: Establish Metering Plan A. PJM Client Manager sets up meeting to discuss new generation with customer <ul style="list-style-type: none"> • Project Schedule • Revenue and real-time options • PJM metering requirements • Business plan for unit B. Customer applies for eTool Accounts based on business plan C. Confirm metering plan between Market Settlements, Operations Planning & Market Operations D. Finalize Point Exchange List	(81-100d) 20 days	100 days	Section 4
Activity 4: PJMnet Installation A. PJMnet Telecommunications form sent to customer B. PJMnet form filled and returned by customer C. ARCOM Director requested by Customer (if applicable) D. Installation services & components (ARCOM directors, circuits, etc) ordered E. Delivery of installation components F. PJMnet Installation completed	(101-190d) 90 days	190 days	Section 4
Activity 5: Metering & Communications Installation A. Customer Firewalls complete (if applicable) B. Communication paths for RTU & GMS complete C. PJM Real-Time Operations Support Department and Customer verify telemetered data accuracy.	(181-190d) 10 days	190 days	Section 4
Activity 6: Data Exchange Testing A. Begin Testing with PJM B. Verify data exchange accurate C. Communications Online	(191-200d) 10 days	200 days	Section 6
Activity 7: Confirm Voice, Communications & Dispatch Operations A. PJM Technical Architecture Department initiates installation of data communications & circuit testing B. Facilities Department installs voice communications for dispatch services	(191-200d) 10 days	200 days	Section 6
Activity 8: CR&T review Operations Requirements A. Pre-scheduling and Scheduling Requirements B. Unit Commitment C. Dispatching of Generation D. Switching Requirements E. Training and System Operator Certification F. Critical Information and Reporting Requirements G. Compliance with Synchronization and Disconnection Procedures	(191-200d) 10 days	200 days	Section 7



Activity	Duration		Manual Reference
	Activity	Cumulative	
Activity 9: PJM review of Data & Markets A. Market Settlements & operations approve unit plans and establish market accounts	(201-210d) 10 days	210 days	-
Activity 10: Capacity Status Granted A. Customer applies for Cap Mod status via eCapacity B. PJM Capacity Adequacy & Planning grant capacity status	(211-215d) 5 days	215 days	-

Exhibit 1: Generator Markets and Operations Process Flow and Timeline

1.2 Generator Commercial Naming Convention

New generation in PJM is assigned a commercial plant or unit name by PJM and the developer prior to its incorporation in the PJM model. The commercial names must be initiated at the execution of the Interconnection Service Agreement or even earlier based on the nature of the project. The following convention has been established for assigning commercial plant or unit names to new generation projects.

1. The commercial names will be assigned by PJM in collaboration with a representative from the developer, PJM Interconnection & Generation Planning, Capacity Adequacy Planning, Market Settlements and Power System Coordination Departments.
2. Where possible, the commercial names will be associated with the assigned name given by the plant owner to maintain consistency during construction and the future operation of the plant.

NOTE: The name of the developer is generally recognized as unacceptable as future projects by the same developer may cause similar confusion.

3. In the event that existing units are already named after the assigned name given by the plant owner, and it is deemed inappropriate to add additional sequential numbers to the existing units' naming convention, a local geography name (in a Township, Borough or Town designation) or PJM substation will be used based on the physical location of the generation.
4. In the event that a local geography name has already been used in another part of PJM, a local landmark will be identified and used for the PJM naming convention.
5. In any event, the generator name will be unique and differentiate itself from other names already used within the PJM system, or neighboring systems if known.
6. The assigned PJM name will be circulated by the Power System Coordination Department to Interconnection & Generation Planning, Capacity Adequacy, Member Relations, Performance Compliance and Market Settlements departments for sign off/ approval before publication to all of PJM and the customer. After the final sign off is received, the Power System Coordination Department will circulate the name, queue number, etc. to all PJM appropriate parties and the customer.



Section 2: Responsibilities of Generation Owners

Welcome to the *Responsibilities of Generation Owners* section of the **PJM Manual for Generator Operational Requirements**. In this section you will find the following information:

- A listing of significant obligations of Generation Owners in the PJM Balancing Authority (see *Generator Owners' Responsibilities*”).

2.1 Generator Owners' Responsibilities

A Generation Owner in PJM is a Member that owns or leases with rights equivalent to ownership facilities for the generation of electric energy that are located within the PJM Balancing Authority or within the PJM West Region. Membership in PJM entails execution of the Operating Agreement and satisfactions of the data requirements, operational and market coordination, committee support and financial obligations contained within the agreement.

The responsibilities for a Generator Owner within PJM that are defined below are required to maintain the safe and reliable operation of the PJM Interconnection. The generator owner under PJM's direction takes all actions possible to maintain PJM Interconnection reliability. The responsibilities identified below are consistent with the NERC Functional Model for interconnected system operation.

This list is a collection of significant operational responsibilities and obligations of a Generator owner that are included in the PJM OA, PJM RAA, PJM West RAA and the PJM Procedure manuals. It is not intended to be an all-inclusive list of every responsibility and obligation of a Generator owner.

A Generator Owner:

- Is subject to applicable code of conduct and other applicable confidentiality agreements. (PJM OA Sect. 1.7.4a)
- Takes action to maintain local reliability and public safety. (PJM OA Sect. 1.7.4a)
- Operates generation system facilities under the direction of PJM. (PJM OA Sect. 1.7.4f)
- Operates generation facilities in accordance with all federal and state regulations and PJM procedures. (PJM OA Sect. 1.7.4f, PJM RAA Schedule 2.B.2)
- Maintains generation facilities in accordance with good utility practice and PJM standards. (PJM OA Sect. 1.7.4g, PJM RAA Schedule 2.B.2)
- Establishes capability of its generation facilities and provides this information to PJM and the Local Control Center (LCC) if the facilities are designated PJM capacity resources. (PJM Manual M-21 Section 1)
- Provides annual baseline and real time updates of fuel limited generating units to PJM during emergency conditions. (PJM Manual M-13 Section 5)
- Complies with the data information and metering requirements established by PJM. (PJM Manual M-14D Section 4, PJM West RAA Schedule 8.1)



- Maintains assigned voltage schedules and responds promptly to specific requests and directions of the PJM dispatcher or the LCC dispatcher in event of low/high voltage situations. (PJM Manual M-12 Section 5 Voltage Control)
- Follows directions from the LCC for switching interconnection points.
- Helps maintain a reliable transmission system by providing reactive capability curve information to PJM as soon as the information is available. (PJM Manual M-03 Section 3 Generating Unit Reactive Capability)
- Complies with procedures called for by PJM or the LCC in event of operating limit violations and other emergency conditions. (PJM Manual M-13)
- Provides real-time operations information to PJM in compliance with PJM procedures. (PJM Manual M-14D Section 4, PJM RAA Schedule 2.B.3)
- Provides information about planned, maintenance and unplanned outages of generation facilities to PJM. (Manual M-10 Section 2, PJM West RAA Schedule 8.3)
- Supplies engineering data for generating unit models to PJM. (PJM Manual M-05 Section 1)
- Develops, documents, and communicates operator guidance, as necessary. (PJM Manual 14 Section 4 Training)
- Plans and coordinates generation outages.
- Works with PJM to mitigate identified reliability concerns for planned generation outages. (Manual M-10 Section 2)
- Large generating plant owners with market operations centers (MOCs) must maintain continuous staffing and meet all of the communication and information system requirements defined by PJM. (PJM Manual M-01, PJM OA Sect. 1.7.5, PJM RAA Schedule 2.B.3)
- Personnel Requirements (PJM Manual M-01 Section 2 Control Center Staffing) - Generation system operators shall:
 - Be competent and experienced in the routine and abnormal operation of generators within interconnected systems.
 - Be accountable to take any action required to maintain the safe and reliable operation of the generation facility.
 - Have thorough knowledge of PJM procedures and their application.
 - Have a working knowledge of NERC and MAAC guides and how they coordinate with PJM manuals.
 - Have an understanding of routine protection schemes for PJM generation facilities.
 - Have knowledge of how to evaluate desired system response to actual system response.
 - Have knowledge of and be able to evaluate and take action on equipment problems in generation facilities.
 - Have knowledge of the general philosophy of system restoration and the philosophy and procedures of their company as well as that of the pool.



- Have initial and continuing training that addresses the required knowledge and competencies and their application in system operations.
- Have current PJM Generation System Operator Certification
- Plant Personnel should have a working knowledge of switching and tagging procedures for the generation facility
- Develops, documents, and maintains switching and tagging procedures (OSHA 29 CFR Part 1910.269).
- Is accountable for directing station forces in generation system switching activities
- Follows up on significant system events with an investigative process to analyze, document and report on operating abnormalities. (PJM Manual M-13)
- Generator owners providing black start services will follow procedure outlined by PJM (PJM Manual M-10 Section 2, PJM Manual M-12 Section 4, PJM Manual M-27 Section 10)



Section 3: Control Center Requirements

Welcome to the *Control Center Requirements* section of the **PJM Manual for Generator Operational Requirements**. In this section you will find the following information:

- A description of the generation control center categories within PJM (see *PJM Control Center Categories for Generating Entities*”).
- A summary of control center requirements for generation owners (see *Control Center Requirements for Generating Entities*”).
- Voice communication requirements for generation owners (see *Voice Communication Requirements for Generating Entities*”).

This section presents a summarized version of the requirements for control centers established by generating entities for reliable operation in the PJM Balancing Authority. For more details, please refer to the **PJM Manual for Control Center and Data Exchange Requirements**.

3.1 PJM Control Center Categories for Generating Entities

PJM Members may be involved with transmission operations, generation operations, load service operations, and/or PJM Energy Market participation. For each of these operations, a different control center category has been designated.

For generation operations, the control center category is the Market Operations Center (MOC), which is established by participating generating entities to facilitate their responsibilities regarding the security of the PJM Balancing Authority.

For each of the services listed, data is exchanged between the MOC, PJM and one or more of the other PJM member control center categories – Local Control Centers (LCCs), Load Service Centers (LSCs), and Marketing Centers, corresponding to Regional Transmission Owners, Load Serving Entities and Marketers.

- Generation Scheduling Services
- EMS Services
- Historical EMS Data Services
- Energy Transaction Services
- Long-term Planning Services
- PJM Administration Services

3.2 Control Center Requirements for Generating Entities

This section discusses the control center requirements for the PJM generating entities, which are similar to those of other PJM members. For efficient and reliable participation in the PJM Balancing Authority, the following requirements for the members' control center computer systems, communications, facilities, and staffing have been established.



3.2.1 Computer System Requirements

The generation owner's MOC serves as the primary operating link to the PJM control center and includes computer system hardware and software that supports their responsibilities under the Agreement. The list below summarizes the computer system requirements for all PJM member control center categories including the MOC.

The control center is required to:

- Achieve a 99.95% availability level for its computer hardware and software
- Prepare and implement a backup and archiving plan
- Follow PJM computer system security procedures
- Follow PJM system maintenance procedures
- Ensure expansion capability of its computer system

3.2.2 Communications Requirements

Telecommunications (voice and data) circuits, which must be reliable and secure, should be tested regularly and/or monitored online, with special attention given to emergency channels.

3.2.3 Facilities Requirements

The MOC facility considerations include the physical space housing operations staff and, if appropriate, a computer room, communications room, and power supply area. The specific implementation of control center facilities considerations should be appropriate for the nature of the computer systems and communications equipment installed. The following list summarizes the facilities requirements for a generation owner.

The control center is required to:

- Provide an environment suitable for its equipment and personnel
- Ensure a stable and secure supply of AC power for its equipment
- Restrict access to its work area to avoid distractions
- Establish a protocol for information flow to control room personnel
- Install smoke and fire detection and protection equipment
- Comply with PJM backup procedures

3.2.4 Control Center Staffing Requirements

MOCs should be staffed 24 hours a day, 7 days a week, with 99.9% availability of personnel who are trained for all normal and emergency situations that are anticipated. Training courses for operations, technical staff and maintenance personnel should be conducted. The PJM Customer Relations and Training Department can provide assistance, as required, for training related to PJM operations.

As of March 1, 2003, PJM requires all generation and transmission operators who operate on PJM systems to undergo the PJM Certification examination. Further details are provided in PJM Certification and Training Requirements (Manual 40) and Section 6 of this manual.



For details on MOC control room operator staffing levels and operational guidelines as well as staffing guidelines in the event of loss of an EMS, please refer to the PJM Manual for ***Control Center and Data Exchange Requirements***.

3.3 Voice Communication Requirements for Generating Entities

This section summarizes the PJM requirements for primary voice and facsimile communications and alternate voice communications for control centers including the MOCs established by generating entities.

3.3.1 Dispatch Voice and Facsimile Communications

The dispatch voice system provides high-priority voice communications between PJM and various PJM Members. The dispatch voice system hardware consists of the All Call system, Ring Down circuits, and manual dial circuits. Equipment at PJM includes an IPC Tradenet and BT digital switch and a Nortel Meridian PBX. Access and interfacing to the communications service providers is configured so that either switch can operate in stand-alone mode, but economy and performance are optimized when they are operating together.

Communications via facsimile machines is another redundant means of exchanging information between PJM operations, accounting, and planning personnel and all categories of PJM Members.

3.3.2 Alternative Voice Communications

The dispatch voice system (All Call, Ring Down, and manual dial PBX) is designed to provide voice communications during normal circumstances. Should the PJM primary All Call System, Ring Down, Manual Dial, and Facsimile Communication fail, the following systems provide alternative communication capabilities in the event the normal system is not effective for some reason:

- Business Voice System
- Cellular Telephones
- Satellite Telephones



Section 4: Data Exchange and Metering Requirements

Welcome to the *Data Exchange and Metering Requirements* section of the PJM Manual for **Generator Operational Requirements**. In this section you will find the following information:

- Description of computer system data exchange methodology and requirements. (See "*Computer System Data Exchange*").
- Rules pertaining to generator metering. (See "*Data Exchange and Metering Requirements*").

4.1 Computer System Data Exchange

4.1.1 PJMnet Communications System

PJMnet is the primary wide-area network for communicating Control Center voice and data to and from PJM. PJMnet will support:

- Inter-Control Center Communications Protocol (ICCP) data links to Control Centers.
- SCADA links to plants via remote terminal units (RTUs) using Distributed Network Protocol (DNP3.0 Implementation Level 2). In the event that the participant(s) cannot handle TCP/IP transport for the DNP implementation, an ARCOM director can be used to facilitate this connection.
- Generator All-Call to Control Centers.

PJMnet is a dual-redundant Frame Relay network that connects member Control Centers and plants to PJM's primary and emergency backup Control Centers. Private voice and data permanent virtual circuits (PVCs) are provided to link to PJM's primary and emergency backup Control Centers. The number of physical interfaces and their capacity will be determined by the impact of your facilities on overall PJM Operations.

For installation of PJMnet, new generator participants are required to complete and return the PJMnet Telecommunications Request Form (see Attachment B) which will be sent to them.

4.1.2 Energy Management System (EMS)

Information is exchanged between the PJM Interconnection L.L.C. (PJM) EMS computers and the EMS systems of PJM Members. Please note that the following description of EMS-to-EMS Data Communications is based on Member company systems that support both Generation and Transmission functions; a Generation Control Center or a Transmission Control Center would need to support the appropriate subset of these functions. The system primarily supports real-time functions such as PJM Balancing Authority network monitoring, generation control, and security analysis.

4.1.3 PJM EMS Communication Protocols

All new Control Center to Control Center links will be implemented using the Inter-control Center Communications Protocol (ICCP) standard. ICCP is a comprehensive, international standard for real-time data exchange within the electric power utility industry. It is intended



to support inter-utility, real-time data exchange critical to the operation of interconnected systems.

A detailed description of the format and content of the ICCP Conformance Blocks (as adapted to PJM needs) may be found in the PJM document *ICCP Network Interface Control Document (NICD)*, dated March 27, 2000.

Request this document from PJM Customer Relations. Other documents that may be supplied to PJM Member-applicants include documents describing data types and message structures as well as supplying detailed information on network protocol and line discipline.

4.1.4 EMS Data Exchange

EMS data is exchanged between each Member's system and the PJM EMS computer system on one of several fixed cycles, as well as on demand, by exception, and interactively.

- The EMS data sent cyclically from PJM Members to the PJM includes:
 - Data needed for the PJM control programs
 - Data needed for monitoring generation
 - Data needed for monitoring transmission
 - Data needed for monitoring interchange
- The EMS data sent cyclically from the existing PJM EMS to each PJM Member's EMS includes:
 - System control data
 - Generation and transmission information required for monitoring and security analysis programs
 - Area Regulation data

Cyclic data exchanged at the fast scan rate (two seconds) is used to develop the PJM Area Control Error (ACE) and associated individual PJM Member Area Regulation megawatt values. Cyclic data exchanged at a slower scan rate (ten seconds) is used to develop dispatch control values, security monitoring, and data tracking.

Cyclic data sent hourly from PJM Members defines the accumulated energy values. PJM Members are responsible for the accuracy of the data they send to PJM. A maximum of 1% overall inaccuracy in the repeatability of data from transducers or potential transformers/current transformers is allowed for instantaneous monitored values (real time data).

Further information may be found in Section 5 of the PJM Manual for Control Center and Data Exchange Requirements.

Hourly MWh readings data must be the same values that are recorded in the history registers of the revenue meters at the metered locations. Billing data has a higher overall accuracy requirement than real time data. Regular calibration of PJM Member metering is necessary to keep the data as accurate as possible. Further information may be found in Section 4 of the PJM Manual for Control Center and Data Exchange Requirements.



Data exchanged either by exception, on demand, or interactively between PJM Member's and the PJM's EMS systems include:

1. Breaker, disconnect, and line status changes, with associated data quality code information.
2. Hourly MWh values for tie-lines and generators.
3. Alarm messages in text and data format.
4. Pre-formatted reports in text and data format.

The following exhibit summarizes the data requirements and exchange rates for the cyclic data exchanged between PJM EMS and PJM Members' EMS systems.

Data	Exchange Rates
From PJM Members to PJM	
Data needed for PJM Control Programs (AGC tie-line MW, Locally Sampled Frequencies)	Fast Scan Rate (2 seconds)
Data needed for monitoring generation (Generation MW Telemetry)	Slow Scan Rate (10 seconds)
Data needed for monitoring transmission (Line/Transformer Flows, Voltages)	Slow Scan Rate (10 seconds)
Accumulated Energy Values	Hourly Exchange Rate
Breaker, disconnect, and line status changes	By Exception (on event)
From PJM EMS to PJM Member's EMS	
AGC Regulation Signals	Fast Scan Rate (2 seconds)
AGC Individual Unit MW Set Points	Slow Scan Rate (10 seconds)
Dispatch control values	Slow Scan Rate (10 seconds)
Generation MW Telemetry	Slow Scan Rate (10 seconds)
Line/Transformer Flows and Bus Voltages	Slow Scan Rate (10 seconds)

Exhibit 2: Summary of EMS Data Requirements and Exchange Rates

Each PJM Member is responsible for determining data-quality indicators for all data transmitted to PJM. Both failed individual values and any value calculated using a failed point must be flagged. When a point fails for an extended period, a manual update of the point's value is necessary once every thirty minutes to keep the data as accurate as possible.

4.1.5 EMS Model

New generators of more than 10 MW or any new capacity resource intending to set real-time LMP must be explicitly modeled in the PJM EMS network model. The EMS network model is updated twice in a year, during the months of April and November. For a new generator to



be included in an EMS model update, all technical modeling information must be submitted to PJM before the following deadlines:

Target In-Service Date	EMS Model Update Date	Info Submitted Before
May 1 to November 30	April	February 15
Dec 1 to April 30 (next year)	November	September 15

Exhibit 3: Deadlines for Modeling Data to Be Submitted

4.1.6 SCADA—Supervisory Control and Data Acquisition

The PJM SCADA system allows PJM to communicate directly with individual generators or smaller Control Centers. The system uses computer, database and digital communications technology to implement the use of common standards in an open environment, independent of any particular vendor or proprietary protocols system.

The PJM SCADA system is designed to allow transfer of both generation and revenue data via one system. A data concentrator (e.g. Remote Terminal Unit, Generator Control System, etc.) is located at the Member's site, and, after collecting data from the industrial metering equipment, communicates with PJM's SCADA system using either DNP 3.0, Level 2 (Distributed Network Protocol) or ICCP (Inter-Control Center Protocol).

The system allows real-time bi-directional transfer of analog and digital data into the system database for storage and real-time transfer to the EMS system.

Information can also be sent from the EMS system through the SCADA system via ICCP and/or DNP 3.0 to the customer, allowing for Automatic Generation Control (AGC), analog set point, device control, and other functions.

NOTE: Although DNP 3.0, Level 2 is a minimum functional requirement, the additional installation of object 23.5 is strongly recommended for all users. Without this object installed, collection of revenue data becomes difficult.

Real-Time Customer Connection

All customers connecting to PJM in real-time must be able to support a minimum data model or connection to PJM will not be allowed.

All data items, regardless of type, are collected and disseminated at the same 2-second rate. Instantaneous MW and MVAR information is collected on the same data scan as Integrated MWh and MVARh. The MWh and MVARh quantities represent the integrated energies of the previous hour. This configuration minimizes the number of data scan types and simplifies the definition of the customer information in the SCADA database.

Components of the real time information will be periodically collected and stored temporarily in the SCADA/EMS internal database. This allows the hourly revenue information to be extracted from the instantaneous data stream for eventual transmission to the PJM Market Settlement System.

Non real-time MWh and MVARh data transfer are also used as a backup method of retrieving the hourly data lost because of a system or communications failure. This mechanism (object 23.5) is used to fill in any data holes in the integrated information detected by SCADA prior to the transmission of that information to the PJM Market



Settlement System. A data hole is created when the connection to a real-time customer is interrupted for one hour or longer for any reason.

Once the connection to the real-time customer is re-established, SCADA will initiate a DNP 3.0 Class 3 event poll of the object 23.5 data to initiate the transfer of the already-collected revenue information stored in the data concentrator. When the transfer is complete, the missing information will be inserted into the SCADA database. The non real-time information collected in this mode is the same type of information periodically collected from the instantaneous data stream in the real-time customer connection.

Non-Real-Time Customer Connection

This mode of non-real-time data transfer is necessary to support customers that request connection to PJM for revenue information transfer, but do not meet PJM's minimum requirements for instantaneous data transfer.

All customers connecting to PJM in a non-real-time mode must be able to support a minimum data model or connection to PJM will not be allowed.

Physical connection to the customer will be accomplished prior to data transfer, and depending on the transport, disconnection may take place immediately after data transfer is complete.

A refresh of the instantaneous information from this class of customer may be initiated by the PJM SCADA every 5 to 15 minutes.

The non-real-time transfer of information (Integrated MWh and MVARh, etc) will be accomplished every 1 to 24 hours.

Once this connection is established, SCADA initiates a Class 3 event poll of the object 23.5 data to initiate the transfer of already collected revenue data stored in the data concentrator or meter.

Once the data transfer is complete, the information collected will be temporarily stored in the SCADA database and eventually transmitted to the Market Settlements ORACLE database using SQL Net. The non-real-time information collected in this mode is the same type of information periodically collected from the instantaneous data stream in the real-time customer connection.

Sample Configurations

The wide variety and unknown quantity of possible Members dictates that the system cannot be locked into a fixed configuration. Member size and type of installation (new or existing) determine the installation configuration and possible features.

Some of the possible configurations are shown below. All metering installations below accommodate one or more metering points. Please note that the following table is a guideline only. Specifics of the installation may dictate an alternate configuration.



Generator Size	Metering Installation				
	IED	Data Model	Configuration	Monitoring Period	Protocol
Very Small (<10 MW)	Data Concentrator	All data types available OR Collect MWh and MVARh only	Dedicated TCP/IP with encryption gateway over secure internet.	2 Second Periodic	DNP 3.0
Small (10–100 MW)	Data Concentrator	All data types available	Dedicated TCP/IP with encryption gateway over secure internet.	2 Second Periodic	DNP 3.0
Medium (>100–500 MW)	Data Concentrator	All data types available	Dedicated TCP/IP with single router to redundant frame relay networks.	2 Second Periodic	DNP 3.0 or ICCP
Large (>500 MW)	Data Concentrator, SCADA, EMS or GMS	All data types available	Dedicated TCP/IP with dual routers to redundant frame relay networks– Single Local Area Network	2 Second Periodic	DNP 3.0 or ICCP

Exhibit 4: Guidelines for Metering Installations



The table below shows the types of equipment necessary for exchanging data with PJM.

Situation	Real-Time & Billing Metering	Operational Changes Sent via	Generator Bidding
Minimum Changes/Minimum Cost	Via Host Utility; MWh entered in eMeter for PJM billing.	Host Utility.	Via Host Utility
<10 MW injection to grid or unit runs infrequently.	RTU at plant, single DNP network connection with encryption gateway.	Internet, through eMKT	Internet, through eMKT
>10 MW and <100MW injection to grid; unit runs continuously.	RTU at plant, single DNP network connection with encryption gateway.	Internet, through eMKT	Internet, through eMKT
>100 MW and <500MW injection to grid; unit runs continuously.	RTU at plant, redundant network connection, single router.	Internet, through eMKT	Internet, through eMKT
>500 MW injection to grid; unit runs continuously	RTU at plant or ICCP via SCADA system, redundant ICCP or DNP network connection, dual routers.	Internet, through eMKT	Internet, through eMKT
Control Center for Multiple Units	Install metering and use SCADA System; redundant ICCP network connection to PJM, dual routers.	Internet, through eMKT	Internet, through eMKT and PJMnet

Exhibit 5: Equipment Types for Data Exchange with PJM

The following exhibit displays a typical multi-unit metering and data flow configuration.

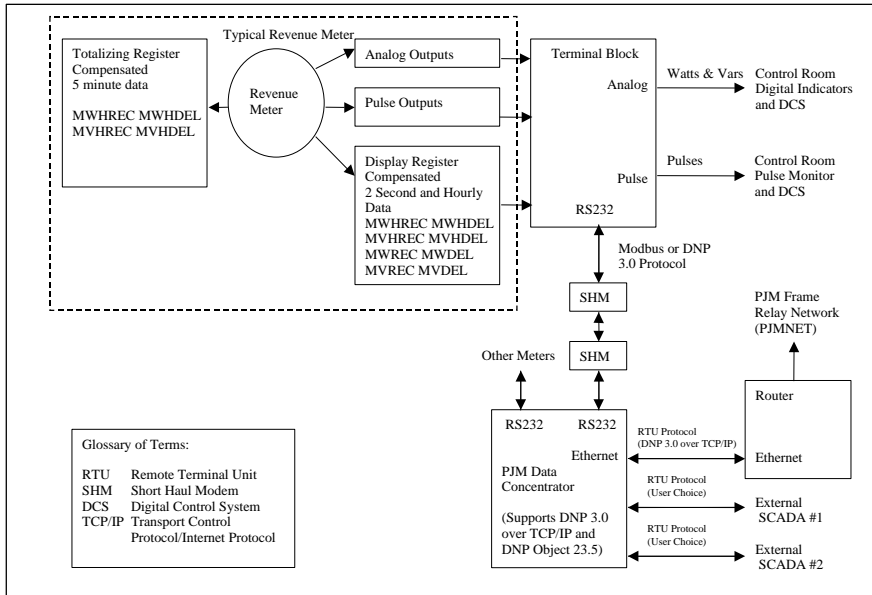

Exhibit 6: Typical Multi-Unit Metering and Data Flow Configuration

The following exhibit shows PJM precision requirements for real-time and revenue metering information.

Real Time Instantaneous Data Sent To PJM	
Frequency	1/1000th of HZ (i.e. 60.001 Hz)
Voltage	1/10th of kV (i.e. 69.1 kV)
Real Power MW	1 MW integer (i.e. 52 MW) required, but PJM will accept greater precision if available
Reactive Power MVAR	1 MVAR integer (i.e. 42 MVAR) required, but PJM will accept greater precision if available
Regulation Capability MW	1 MW integer (i.e. 10 MW)
Real Time Instantaneous Data Sent From PJM	
Lambda cost signal	1/10th of \$/MWh (i.e. 23.1 \$/MWh)
Regulation Signal (AR)	1 MW integer, + or - (i.e. 10 MW)
Revenue Data Sent To PJM	
MWh Delivered and Received	1/1000th of MWh (i.e. 20.001 MWh)
MVARh Delivered and Received	1/1000th of MVARh (i.e. 15.002 MVARh)

Exhibit 7: PJM Real-Time and Revenue Data Precision Requirements



4.2 Data Management and Metering Requirements

4.2.1 Data Management and Security

Each Generator shall supply the necessary planning and operating data required to accurately model, schedule, and monitor the PJM system. Specific data requirements for power system applications, production cost and reliability assessment are located in the PJM Manual for Data Management. This data must include, but is not limited to:

- Expected unit operations and desired market service/segment.
- Stability study data.
- Step-up transformer data (impedance and tap setting).
- Relay settings and generator protection package.
- Generator operating curves and associated test data (reactive/saturation).
- Special operating restrictions (including environmental).
- Identification of equipment ownership and maintenance responsibilities.
- Test data for metering calibration, backup communications, and relays.
- Any other data required to certify a generator as eligible to participate in a specific market segment or service.

The Generator shall also provide telemetered data via DNP 3 protocol to the Supervisory Control and Data Acquisition (SCADA) system or via ICCP to the PJM Energy Control System computer. Computer systems and metering shall be consistent with PJM practices, and compatible with PJM computer and communication systems.

Examples of this required data include: MW, MVAR, MWh, voltage, and equipment status (i.e., open/close). The data is to be provided in accordance with standards contained with the ***PJM Manuals for Control Center and Data Exchange Requirements, Pre-Scheduling Operations, Scheduling Operations, and Balancing Operations***. PJM may require the ability to disconnect the facility from the PJM system via the Local Control Center's SCADA system.

It is required that data be sent to PJM automatically. In the event that the data is not automatically received by PJM, the generator operator shall call PJM with the required data at intervals specified by PJM. The generator operator must correct any problems associated with the failure of data-transmission equipment within a reasonable time.

The Generator and Local Control Center shall promptly exchange all information relating to all conditions which affect (or could affect) the operations of any facility reporting data.

The Generator shall communicate the outage of any data communication equipment connecting the facility to the PJM system in accordance with the following requirements:

- Each facility will be assigned to one of the PJM Local Control Centers as its primary contact, unless arrangements are made to communicate information directly to PJM. The assignment is based upon the voltage level of the connection to the Transmission System and the geographic location of the facility.



- All planned and maintenance outages of data communications equipment requiring the involvement of PJM personnel must be requested by the Generator. All information must be in a format defined by PJM.
- Advance notification of planned and maintenance outages must meet the requirements defined in the PJM Manual for Pre-Scheduling Operations.

Additional specific data requirements are defined in other sections of this manual. All records must be retained in accordance with NERC, FERC and PJM data retention requirements. All back-up voice and data communication plans and test procedures must be documented and provided to PJM.

4.2.2 Metering Plan

In order to establish a metering plan for new generation, a PJM Client manager is assigned. A kick-off meeting between the client manager and the generation owner will be held to discuss the following issues:

- Project schedule including testing/commercial dates
- Options for providing real-time and revenue data
- Business plan for the unit(s) - The new participant is required to apply for the necessary eTool accounts based on the individual business plan.
- PJM metering requirements - To satisfy these requirements, all generators connecting to the PJM system are required to install and operate metering and related equipment capable of recording and transmitting all voice and data communications. Specific data metering requirements depend on the size and business plan of the generator connecting to the PJM system.
- All generators that participate in the PJM market as a capacity resource must provide instantaneous power and reactive power flow (real-time telemetered) data, regardless of MW size.
 - Distributed generators modeled at less than 10MW must provide instantaneous power data at the BES injection point within 10% of hourly MWh revenue accumulated data
- Generators that **are not** participating as capacity resources must provide instantaneous real power and reactive power flow data only if:
 - They are 10 MW or larger, or
 - They are greater than 1 MW and connected at a bus operating at 34 kV and above
- Very small generators (less than 10 MWs) may not be required to supply real-time telemetered information. PJM will evaluate requests not to supply real-time telemetry. Evaluation will consider network security and market requirements. Generators that are not required to supply real-time (two-second scan) metering will not be eligible to set real-time LMP. Revenue-related information is necessary for very small units. This information can be obtained from the local utility or manually read by the customer and supplied to PJM. If desired, a direct connection to PJM can be established.



- Generators that are required to supply real-time and revenue information can supply this through the local utility's connection to PJM, or if desired, via a direct connection from the generator to PJM. Real-time information will be collected at a two-second data rate, and revenue information will be collected hourly. The revenue information represents the accumulated energy for the previous hour.

The required revenue information is necessary to satisfy the needs of PJM's Market Settlements program. The real-time information is required for PJM's Energy Management Applications (State Estimator, Security Analysis, etc.).

4.2.3 Metering for Individual Generators

PJM does not require generator owners to directly connect to PJM, but leaves this as an option if it enhances the owner's ability to participate in PJM markets and functions. A generation owner has a number of options with respect to information acquisition and transmission.

At the most basic level, a generator owner can negotiate data transmission to and from PJM through the local utility or transmission facilities owner. This allows the generator owner the flexibility to use already proven and acceptable methods of data transfer to minimize initial start-up costs and procedures, while meeting all of the current requirements for providing data to PJM. This basic communication can be supplemented with the use of the Internet-based eSchedules and eData, further expanding the data transfer capabilities between the customer and PJM without a direct connection to PJM.

A generator owner may decide that direct connection to PJM makes the best business sense, so facilities have been provided to make that connection as simple and cost effective as possible. The generator owner that decides to connect directly to PJM will be required to meet requirements determined by the net MW produced and the markets in which the generator owner decides to participate.

Additionally, information about PJM's operational status and other types of non market-sensitive data can be directly communicated through these same facilities. This type of communication is not required but is provided by PJM as a value-added service to enhance participation in PJM markets.

PJM's data requirements are described in two categories: real-time information and non real-time information. Either or both of these types of data can be directly communicated to PJM depending on the customer requirements and operating agreement with the local utility.

Real-Time Data

Real-time or instantaneous information is defined as data required by PJM that determines system security and stability as well as congestion and LMP. The minimum data model for real-time data transmission requires:

- Instantaneous Net (+/-) MW for each unit, measured on the low-side of generator step-up transformer
- Instantaneous Net (+/-) MVAR for each unit, measured on the low-side of generator step-up transformer



- Distributed generators modeled at less than 10MW must provide Instantaneous Net (+/-) MW and MVAR at aggregation point (BES injection point) based on an agreed upon algorithm.

Additional transmitted data may include bus voltages, circuit breaker status, and other data.

Account Metering

Non-real-time or revenue information is needed by PJM's applications and systems that determine Grid Accounting and Energy Interchange. The minimum data-model for revenue data transmission requires:

- Hourly Compensated MWh delivered for each unit.
- Hourly Compensated MWh received for each unit.
- Hourly Compensated MVARh delivered for each unit (not currently required).
- Hourly Compensated MVARh received for each unit (not currently required).

Note: The MVARh revenue information will be considered a requirement in the event that PJM implements a Reactive Power Market.

Additional information on PJM Metering requirements may be found in Sections 4 and 5 of the ***PJM Manual for Control Center and Data Exchange Requirements***.

Data Communications Systems and Requirements

Data communications systems and requirements are dependent on the type of facilities connected to PJM, category of generator(s) based on Net MW, and market participation. The Generator owner with facilities directly connected to PJM must, at a minimum, provide PJM with the contact name and voice phone number of person or persons responsible for the continuous operation of that equipment.

Additionally, the Generator owner with multiple connected facilities may have to provide centralized contact and control information to minimize confusion and downtime resulting from equipment failure. Additional data or control room functionality may be necessary and will be determined on a per-generator basis.

For questions about Data and Metering Requirements, contact PJM's Customer Relations at 610-666-8980.



Section 5: Participation in PJM Markets

Welcome to the *Participation in PJM Markets* section of the *PJM Manual for Generator Operational Requirements*. In this section you will find the following information:

- Description of marketing options available to Generator Owners (see "*Marketing Options*").
- Description of required/mandatory services (see "*Ancillary Services*").
- Description of PJM marketing tools that are currently available (see "*Marketing Tools*").
- Description of the PJM two-settlement system (see "*Description of the Two-Settlement System*").
- Role of Generation in the PJM pre-scheduling and scheduling processes (see "*Pre-Scheduling and Scheduling*").
- Description of the resource commitment process (see "*Resource Commitment*").

5.1 Marketing Options

There are several marketing options available to generator owners in the PJM Interconnection L.L.C. (PJM) Balancing Authority, but not every generating unit qualifies to participate in every PJM market. The marketing options available to generation owners depend on the physical characteristics of the unit(s) as well as the business philosophy of each owner. Additional information on all of the PJM markets may be found at the heading "PJM Markets" on the PJM Web site.

5.1.1 PJM Wholesale Energy Market

The PJM wholesale energy market includes both day-ahead and real-time markets.

- In the day-ahead market, Locational Marginal Prices (LMPs) are calculated for each hour of the next operating day based on generation offers, demand bids, and bilateral transaction schedules submitted in advance. The next-day schedule is developed using least-cost, security-constrained resource commitment and security-constrained economic dispatch programs.
- During the operating day, hourly clearing prices are determined by the actual system operations security-constrained economic dispatch.

By entering the day-ahead market, participants may commit to energy prices and transmission congestion charges in advance of real-time dispatch. Additionally, a participant may submit price-sensitive demand bids, increment offers, decrement bids or may inform PJM of the maximum congestion charges it is willing to pay.

PJM receives bids and offers for next-day energy until 1200 (noon); LMPs are posted at 1600 each day, along with hourly schedules. The Balancing market re-bidding period opens at 1600 and continues until 1800. Throughout the operating day, PJM continually re-evaluates individual generation schedules and sends updates as required. Settlements take place in each market; the settlements in the Balancing Market take into account any variations from the scheduling planned in the Day-Ahead Market.



Please refer to the heading "*Description of the Two- Settlement System*" later in this section.

5.1.2 Regulation Market

The PJM Regulation Market provides PJM participants with a market-based system for purchase and sale of the Regulation ancillary service. Generation owners submit resource-specific offers to provide Regulation, and PJM utilizes these offers together with forecasted LMPs and generation schedules produced by the Unit Dispatch system to calculate an hourly Regulation Market Clearing Price (RMCP). This clearing price is then used to determine the credits awarded to providers and charges allocated to purchasers of the Regulation service.

- To be eligible to participate in the Regulation Market, the resource must meet these criteria:
- Generation resources must have a governor capable of AGC control.
- Resource must be able to receive an AGC signal.
- Resource must demonstrate minimum performance standards, as set forth in the PJM Manuals.
- New Resources must pass an initial performance test (minimum 75% compliance required). PJM will rely on owner's data for initial qualification. Resources qualified as of June 1, 2000 are grandfathered.
- Resource must exhibit satisfactory performance on dynamic evaluations.
- Resource MW output must be telemetered to the PJM control center in a manner determined to be acceptable to PJM.

Generators may choose to participate in the PJM Regulation Market. Qualification for this program requires each participating resource to achieve specified performance standards and to be equipped with Automatic Generation Control (AGC).

Generators submit their availability and price on a day-ahead basis; prices for Regulation are capped at \$100 per MWh. Compensation for Regulation is based on the Regulation Market clearing price, which includes the Regulation bid plus any lost-opportunity cost from the energy markets. For more details on regulating unit eligibility and the regulation market business rules, please refer to the ***PJM Manuals for Pre-scheduling Operations and Scheduling Operations***.

5.1.3 Synchronized Reserve Market

The PJM Synchronized Reserve Market provides PJM participants with a market-based system for purchase and sale of the Synchronized Reserve ancillary service. Generation owners submit unit-specific offers to provide Synchronized Reserve, and PJM utilizes these offers together with forecasted LMPs and generation schedules produced by the Unit Dispatch system to calculate an hourly Synchronized Reserve Market Clearing Price (SRMCP). This clearing price is then used to determine the credits awarded to providers and charges allocated to purchasers of the Synchronized Reserve service. For more details, please refer to the ***PJM Manual for Scheduling Operations***.



5.1.4 Capacity Credit Market

Owners of generation serving as a PJM Capacity Resource may submit bids to the PJM Daily Capacity Credit Market or the longer-term Capacity Credit Market. On a daily basis, any excess capacity is required to be bid into the Capacity Credit Market.

Bids are submitted using the eCapacity tool. Through eCapacity, generators may create bilateral capacity transactions or submit capacity modifications to increase or decrease the installed capacity rating of a unit. Load Serving Entities may enter Active Load Management modifications and view peak load and obligation data.

5.2 Ancillary Services

The following ancillary services are provided by PJM in coordination with the generating entities and are required/mandatory services, calculated after-the-fact in the billing process.

5.2.1 Reactive Supply and Voltage Control from Generating Sources Service

In order to maintain transmission voltages on the Transmission Provider's transmission facilities within acceptable limits, generation facilities under the control of the Balancing Authority operator are operated to produce or absorb reactive power. Thus, Reactive Supply and Voltage Control from Generation Sources must be provided for each transaction on the Transmission Provider's transmission facilities.

The amount of reactive supply and voltage that must be supplied with respect to the Transmission Customers transaction will be determined based on the reactive power support necessary to maintain transmission voltages within limits that are generally accepted in the region and consistently adhered to by the Transmission Provider. The charges for such service are shown in Schedule 2 of the Open Access Transmission Tariff. Also, new generators have the option of filing with FERC to receive a revenue stream for their reactive output.

After consultation with the Generator Owner regarding necessary step-up transformer tap changes, PJM will provide documentation to the Generator Owner specifying the required tap changes, a timeframe for making the changes, and technical justification for these changes. The Generation Owner shall provide notification to PJM when the changes have been implemented. Generation Owners shall update reactive curves (D-curves) via eDart to ensure PJM and TO EMS Security Analysis results are accurate.

5.2.2 Regulation and Frequency Response Service

Regulation and Frequency Response service provides the continuous balancing of resources (generation and interchange) with load and maintains the Interconnection frequency at sixty cycles per second (60 Hz). Within PJM, Regulation and Frequency Response service is accomplished through the Regulation Market, which is described in this section under *Marketing Options*.



5.3 Marketing Tools

Additional information on all PJM Marketing tools can be found on the PJM home page at PJM Tools.

5.3.1 eMKT

This is the Market User Interface for participating in the PJM Wholesale Energy Markets, specifically the Day-Ahead Market, the PJM Regulation Market, and the PJM Synchronized Reserve Market. Users may submit resource-specific generation offers with operating details, fixed or price-sensitive demand bids, as well as bilateral transactions and financial increment and decrement bids. The PJM eMKT interface also enables viewing public and private day-ahead results and managing portfolios. New users should submit information under User Registration from the Market User Interface.

5.3.2 Markets Database

The PJM Markets database, a subsection of the eMKT tool, contains generator information including owner, plant, operating limits, and resource availability details. This data allows PJM to reliably pre-schedule, schedule and dispatch generation within the PJM Balancing Authority.

Generators may initially submit cost-based or price-based bids to PJM. Cost-based bids are subject to the rules approved by the PJM Board. Cost-based bidders are allowed to submit start-up and no-load costs daily but may be audited for accuracy.

Price-based bids are not subject to audit, but start-up and no-load costs can only be bid in biannually. All generators must also have a cost-capped bid on file. After a price-based bid has been submitted, the generation owner no longer has the option to return to cost-based bidding for that unit.

5.3.3 PJM eSchedules

This tool is used by Generation Owners in PJM to submit their internal PJM energy schedule data. All PJM internal transactions, including load and generation interchange adjustment modeling and implicit internal spot market schedules, are handled through the PJM eSchedules system. New users who are PJM Members may register to use eCapacity and eSchedules by submitting the User Registration form from the login screen.

5.3.4 PJM eCapacity

This electronic tool enables a competitive installed-capacity market and fulfills the data reporting requirements for generation owners with granted capacity status. Users of eCapacity can view peak loads and obligations in any zone, shop for PJM installed capacity, and create bilateral transactions to buy or sell unit-specific or capacity credits. New users may register to use eCapacity by submitting the User Registration form from the login screen.

5.3.5 eDART

The Dispatcher Application and Reporting Tool (DART) provides communication with PJM for generation operators regarding unit outage requests, updates to reactive capability curves (D-curves) and AVR status.



When fully implemented, operators will also use this tool to submit data for Supplemental Status Reports (SSRs), Restoration Drill Data, Instantaneous Reserve Checks (IRCs), and Morning Status Reports. Additional applications may be integrated in eDART in the future. User registration is available from the PJM Web site.

5.3.6 eGADS

The Generator Availability Data System (GADS) enables the operators of generation units to submit performance data into PJM records for determination of unit availability. Units are tracked on a rolling twelve-month basis for demand equivalent forced outages (EFORd) to determine their unforced capacity. Operators are required to submit data monthly using the eGADS interface. New plant operators should contact PJM for user set-up.

5.4 Description of the Two-Settlement System

5.4.1 Market Participants

Market Sellers

Market participants owning PJM-designated Capacity Resources must submit offers into the Day-Ahead Market unless the resource(s) is unavailable due to outage. If a Capacity Resource is not scheduled in the Day-Ahead Market, the Market Seller may revise its offer and submit bids into the Real-Time Market or may self-schedule.

A self-scheduled generator must submit hourly MW schedules and may submit a price at which they would reduce output (decrement bid).

An offer of generation must not exceed the \$1000/MWh price cap. An offer from a Capacity Resource remains in effect until specifically superseded by another offer. A resource may submit offer data for up to seven days in the future.

If the notification time, start-up time or time-to-reach-minimum of a Capacity Resource exceeds 24 hours, the Market Seller must submit binding offers for the next seven days. Market Sellers offering combined-cycle units must make available either the schedule for the combustion turbines (CTs) or the schedule for the combined-cycle unit.

PJM

PJM receives, analyzes and posts data via the Market User Interface. To maintain reliable operation, PJM may perform supplemental resource commitments after the day-ahead schedule is posted. Additionally, as a result of analysis, PJM may limit its dependence on combustion turbines to provide reserves. These limits are based on past performance of the resources.

Data posted by PJM includes:

- Total hourly MW quantities as specified in demand bids
- Forecasts of total hourly demand for the next four days and peak demand for the subsequent three days.
- Hourly LMP values for the next operating day at the completion of the day-ahead scheduling process.



- The schedule of demand, supply and bilateral transactions for private viewing by market participants.

5.4.2 The Day-Ahead Market

The Day-Ahead Market allows participants to purchase and sell energy at binding day-ahead prices. It also allows transmission customers to schedule bilateral transactions at binding day-ahead congestion charges. These congestion charges are based on the differences in Locational Marginal Prices (LMPs) between the transaction source and the sink.

Load Serving Entities (LSEs) will submit hourly demand schedules, including any price-sensitive demand, for the amount of demand that they wish to lock in at day-ahead prices. Any generator that is a PJM-designated capacity resource must submit a bid schedule into the day-ahead market unless it is self-scheduled or unavailable due to outage.

Other generators have the option to bid into the day-ahead market. Transmission customers may submit fixed or dispatchable bilateral transaction schedules into the day-ahead market and may specify whether they are willing to pay congestion charges or wish to be curtailed if congestion occurs in the day-schedule.

All spot purchases and sales in the day-ahead market are settled at the day-ahead prices. After the daily quote period closes, PJM will calculate the day-ahead schedule based on the bids, offers and schedules submitted using scheduling programs that perform least-cost, security-constrained resource commitment and dispatch for each hour of the next operating day. The day-ahead scheduling process will incorporate PJM reliability requirements and reserve obligations into the analysis. The resulting hourly schedules and LMPs represent binding financial commitments to the Market Participants. Financial transmission rights (FTRs) are accounted for at the day-ahead LMP values.

Timelines

The day-ahead scheduling/bidding timeline for the two-settlement system consists of the following time frames:

- 1200: Day-Ahead Market bid period closes. All bids must be submitted to PJM. At 1200, PJM runs the two-settlement software to determine the hourly commitment schedules and the LMPs for the day-ahead market. This is the first resource commitment run, to determine the resource commitment profile satisfying fixed demand, price-sensitive demand bids, and operating reserve objectives. This commitment analysis also includes external bilateral transaction schedules and external resource offers into the PJM Day-Ahead Market.
- 1600: Based on the first resource commitment, PJM posts the day-ahead hourly schedules and LMPs on the Web-based Market User Interface (MUI) for the two-settlement system. PJM also makes these results available in downloadable files, via the MUI or a dedicated communication link.
- 1600-1800: PJM opens the Balancing Market offer period. During this time, Market Participants submit revised offers for resources not selected in the first commitment.
- 1800: The Balancing Market offer period closes. PJM performs a second resource commitment, which includes the updated offers, updated resource availability information, updated PJM load forecast information and load forecast deviation.



- 1800: Operating Day. PJM may perform additional resource commitment runs, based on updated PJM load forecasts and updated resource availability information. PJM sends out individual generation schedule updates to specific generation owners.

5.4.3 The Real-Time Balancing Market

The Balancing Market is based on real-time operations. It provides financial incentives for generators to follow the real-time economic dispatch instructions issued by PJM.

Generators designated as PJM Capacity Resources that are available but not selected in the day-ahead scheduling may alter their bids for use in the balancing market. If not altered, the original bids remain in effect for the Balancing Market.

Balancing prices are calculated on the actual system operating conditions as described by the PJM state estimator. LSEs will pay balancing prices for any demand that exceeds their day-ahead scheduled quantities. The LSEs will also receive revenue for demand deviations below their scheduled quantities.

Generators are paid balancing prices for any generation that exceeds their day-ahead scheduled quantities and will pay for generation deviations below their scheduled quantities. Transmission customers pay congestion charges for bilateral transaction quantity deviations from day-ahead schedules. All spot purchases and sales in the balancing market are settled at the balancing prices.

5.4.4 Grid Accounting

There are several services within the Interchange Energy Market for which PJM calculates charges and credits that are allocated among the PJM Members. (Detailed explanations may be found in the *PJM Manual for Operating Agreement Accounting*.)

PJM provides accounting for these services:

- Spot Market Energy—Energy bought or sold by PJM Members through the PJM Energy Market.
- Regulation—The capability of a specific resource with appropriate telecommunications, control, and response capability to increase or decrease its output in response to a regulating control signal (see *PJM Manual for Balancing Operations*).
- Operating Reserves—The amounts of generating Capacity scheduled to be available for specified periods of an Operating Day to ensure reliable operation.
- Synchronized Reserve—Capability of a specific synchronized generating or demand resource that can be provided within ten (10) minutes (see *PJM Manual for Scheduling Operations*).
- Transmission Congestion—The increased cost of energy delivered when the Transmission System is operating under constrained conditions.
- Transmission Losses—Energy requirements in excess of load requirements due to the energy consumed by the electrical impedance characteristics of the Transmission System.



- Emergency Energy—Energy bought from or sold to other Balancing Authorities by PJM due to emergencies either within the PJM Balancing Authority or within the other Balancing Authorities.
- Metering Reconciliation—Metering errors and corrections that are reconciled at the end of each month by a meter error correction charge adjustment.
- Unscheduled Transmission Service—Service that PJM Members can provide to or receive from the New York ISO and are credited or charged according to the Operating Agreement.
- Ramapo PAR Facilities—Carrying charges collected from PJM RTOs paid to the New York ISO for the Phase Angle Regulators (PARs) at Ramapo and charged according to the Operating Agreement.
- Capacity Credit Market—Capacity credits bought or sold through the PJM daily and monthly capacity credit markets.

These services are applicable to the different types of market participation, as shown in the following table. Each service is further broken down in the billing statement (see the **PJM Manual for Billing**).

	Market Buyers	Market Sellers	Transmission Customers
Spot Market Energy	X	X	
Regulation	X	X	
Synchronized Reserve Market	X	X	
Operating Reserves	X	X	
Transmission Congestion			X
Transmission Losses			X
Emergency Energy	X	X	
Meter Reconciliation	X	X	
Unscheduled Transmission Service	X	X	
Capacity Credit Market	X	X	

Exhibit 8: Applicable Services as defined by Market Participation

PJM Energy Market accounting is designed to operate on a balanced basis. That is, the total amount of the charges equals the total amount of credits; there are no residual funds. With certain exceptions, each of the individual services also operates on a balanced basis. Charges and credits for a particular service (such as regulation) offset each other exactly. In certain cases, excess charges or credits in one service category are used to offset charges and credits for another service.

Accounting Input Data

At the end of each operating hour, PJM collects information regarding actual operations during the hour. This information is recorded either by the PJM System Operators or by



automated systems. The market accounting processes use this information as input data. Other accounting input data is provided from various systems and databases. This information includes data describing PJM Members' installed generating resources, scheduling information for PJM Members' transactions, and Transmission System parameters, such as loss factors determined annually by PJM system planning staff.

5.5 Pre-Scheduling and Scheduling

One of the principal purposes of the PJM pre-scheduling activities is to establish and maintain a database containing current generator information. Now named the Markets Database, it was previously known as the Unit Commitment Database (UCDB). The name changed with the introduction of the two-settlement system. The database contains resource-specific information including company, plant, operating limits, resource availability, etc., and is used during pre-scheduling, scheduling and dispatching. This data allows PJM to schedule generation resulting in the lowest overall production cost while maintaining the reliability of the PJM Balancing Authority.

Each Generator must advise PJM on a daily basis of its generation schedule and/or bid price for the following day. Generators must abide by these schedules unless approval for deviation is secured from PJM or unless equipment problems beyond the Generator's control prevent operation at the specified schedule.

Specific details concerning the data requirements and deadlines for the pre-scheduling and scheduling processes are contained in the *PJM Manuals for Pre-Scheduling Operations* and *Scheduling Operations*.

5.6 Unit Commitment

5.6.1 Process

The resource commitment process includes the Markets Database (formerly the Unit Commitment Database or UCDB) and the functions of HydroScheduler and the Dispatch Management Tool (DMT). The Markets Database is a large database containing information on each resource that operates as part of the PJM Interchange Energy Market.

The Resource Scheduling and Commitment (RSC) programs provide an optimized economic commitment schedule for thermal generating units and are the primary tool used to determine commitment of resources that have operating constraints requiring multiple-day operation.

The Hydro Calculator computes hourly reservoir elevations and hydro plant generation from input river flows and hydro plant discharges.

The DMT runs in the corporate computer system and performs accounting and operations functions with respect to combustion turbines. Additional information on the PJM resource commitment process may be found in the following manuals:

- PJM Manual for Pre-Scheduling Operations
- PJM Manual for Scheduling Operations
- PJM Manual for Billing



5.6.2 Data Requirements

The two-settlement technical software develops the Day-Ahead Market results based on minimizing production cost to meet the demand bids and decrement bids. The results incorporate PJM Balancing Authority security constraints and reliability requirements necessary for reliable operation.

Two-Settlement Technical Software

The PJM Two-Settlement Technical Software is a set of computer programs performing security-constrained resource commitment and economic dispatch for the Day-Ahead Market. The individual programs are:

1. Resource Scheduling and Commitment (RSC)—Performs security-constrained resource commitment based on generation offers, demand bids, increment offers, decrement bids and transaction schedules submitted by participants and based on PJM Balancing Authority reliability requirements. RSC will enforce physical resource-specific constraints that are specified in the generation offer data and generic transmission constraints that are entered by the Market Operator.
2. Scheduling, Pricing and Dispatch (SPD)—Performs security-constrained economic dispatch using the commitment profile produced by RSC. SPD calculates hourly unit generation MW levels and LMPs for all load and generation buses for each hour of the next operating day.
3. Study Network Analysis (STNET)—Creates a powerflow model for each hour of the next operating day based on the scheduled network topology, the generation and demand MW profile produced by SPD and the scheduled Tie Flow with adjacent Balancing Authorities. STNET performs AC contingency analysis using the contingency list from PJM EMS and creates generic constraints based on any violations that are detected.

After the close of the generation re-bidding period at 1800, the RSC is the primary tool used to determine any change in steam unit commitment status. Commitment changes are based on minimizing the additional startup costs and costs to operate steam units at economic minimum, as well as providing sufficient operating reserves to satisfy the PJM Load Forecast.

The purpose of this second phase of resource commitment is to ensure that PJM has scheduled enough generation in advance to meet the PJM Load Forecast for the next operating day and for the subsequent six days. CT units are included in the scheduling process and are scheduled in the Day-Ahead Market. However, the decisions concerning actual operation of pool-scheduled CT units during the operating day are not made until the current operating hour in real-time dispatch.

Section 6: Pre-Operational Requirements

Welcome to the *Pre-Operational Requirements* section of the **PJM Manual for Generator Operational Requirements**. In this section you will find the following information:

- Description of data exchange testing procedures (see *–Data Exchange Testing–*).
- Description of required training procedures (see *–Training and System Operator Certification–*).
- Pre-operational requirements of Generation for coordination with dispatch (see *–Goordination with Dispatch–*).

6.1 Data Exchange Testing

6.1.1 Introduction

PJM interfaces with a wide range of different customer systems. Procedures for verifying that these systems are ready to go into production operation vary by type of system, its functionality, the number of data points, etc. For purposes of illustration, test requirements for a Generation Management System (GMS) are provided here. A GMS is typically the most comprehensive system used for generator interconnection, and therefore, has the most comprehensive testing requirements.

By definition, a GMS provides a centralized control center interfacing via remote terminal units to numerous generating locations. This data is then sent to PJM via the Inter-control Center Communication Protocol (ICCP) link.

6.1.2 Test Requirements for New Generator Management Systems (GMS)

In general, PJM is responsible for testing data connections between a Member company's GMS hardware and PJM's computers. PJM generally does not test communication between a Member's remote terminal units (RTUs) and the Member's GMS computers. When using a new GMS system, the Member Company should test input of all RTU information/data into their GMS before involving PJM.

Communication testing by PJM uses the TEST System, which tests the communication of information from the Member's GMS database into the PJM database. If changing from the previous GMS to the new one, testing will be enhanced if all of the data available in the existing GMS is simultaneously available to the new GMS. Where possible, testing of any new GMS should be done from the company's parallel test system connected to the PJM TEST system.

PJM does not require that any RTU be connected to the Member's GMS during testing with PJM's TEST system. The Member Company may have as many RTUs connected to their (new) GMS as they wish while testing with PJM's TEST system. Testing with PJM's TEST shall not reduce the availability of accurate telemetry to PJM's Operational EMS.

The Member Company must comply with these PJM naming and telemetry conventions (if applicable to the installation):

- Transmission line MW and MVAR
- Transformer MW and MVAR



- Generating unit MW and MVAR
- Station kV
- Frequency
- Transformer taps

In addition, the Member Company must support transmission of breaker/disconnect status. Testing should include several scheduled/intentional communication re-starts initiated by both PJM and the testing company.

After the Member Company has successfully completed testing with PJM's TEST System, PJM will schedule the test of the company's new GMS with all telemetry available. The test should comply with the following criteria:

- Real-time metering via ICCP datalink connection must be in place before testing in order to maintain reliability of the PJM Balancing Authority.
- The Member Company must make known when its test period is starting.
- During this time, the Member Company shall maintain the old GMS in such a state that it can be restored in total within one hour upon demand by the PJM Supervising Dispatcher if the new GMS is not performing to the Dispatcher's satisfaction.

Link-uptime for ICCP Links: The link shall be 99.5% operational or higher. PJM shall qualitatively judge whether or not the data is acceptable.

Error Rate Determination for ICCP Links: The error rate is taken from the console log on the communications server. The time between each clui_down and clui_up messages shall be used to determine the down time. The total uptime shall be determined by the time between the first clui_up messages and the last clui_down message.

6.1.3 Communications Considerations

For companies using the TASE.2 (ICCP) protocol, the following specific items should be considered:

- The requirements for communication with PJM over TASE.2 are detailed in two documents: the **PJM ICCP NICD** and the **PJM ICCP Communications Workbook**, which can be obtained from your PJM Project Manager.
- The ICCP association form must be received by PJM for PJM to properly configure the link before any testing can start.
- Before testing with PJM's TEST system, it is desirable for the Member Company's vendor to communicate with the PJM DEV system over a dial-up modem.
- Since TASE.2 runs over TCP/IP and, at PJM both the Real Time EMS and TEST systems are connected, the Member company and PJM must take special precautions to prevent the Member company test GMS from communicating directly to the PJM Real-Time EMS system.

6.1.4 Offline Test

- Both companies will bring the data link up between the Member Company and PJM and verify that all sessions Conformance Blocks (for ICCP) are up.



- Both companies will compare values between the Member company and PJM such as:
 1. Line and transformer flows: All 500 kV, 345 kV, selected 230 kV and tie lines (MW and MVAR),
 2. Generator values
 3. Testing Company Totals
 4. Frequency
 5. Lambda - Cost Signal - verify unit response to cost signal
 6. Regulation (dump plots)
 7. Breaker status
 8. Voltages
 9. Transformer taps
 10. Capacitor VARs
 11. Reactors
 12. Reactive Transfer Limits
 13. Transfer values
 14. Pond levels, integrated values
 15. Loss factors
- Both companies will check the points in the various reporting cycles to see that they are updating at the proper scan rate.
- PJM will have the Member company tel-fail several lines, including facilities at different voltage levels. Companies will compare values, singly and several at once, adjacent and separated in the PTID list. Both companies check for the appropriate flag set in the status code section of the Value Table for the corresponding PTID.
- PJM will have the Member Company restore tel-fails and compare values.
- PJM will have the Member company tel-fail breaker status out-of-service for selected breakers and then restore, checking status each time.
- PJM will have the Member company change a transformer tap and verify.
- PJM will bring up PJM GMS displays and check values on:
 1. bar charts (Member company's generation)
 2. voltages
 3. world map
 4. associated portion of transmission system
- PJM will change scheduled frequency (e.g., 59.98 Hz). Member Company will verify the change.
- PJM will change the system cost. Member Company will verify the change.



- PJM will suspend regulation. Member Company will verify they are receiving a zero regulation signal.
- PJM will unsuspend regulation. Member Company will verify they are receiving the regulation signal the PJM is dispatching.
- PJM will cause the ACE signal to go from a lower to a raised position. Member Company should verify both the correct value and direction.
- PJM will send any one Emergency Procedure (using EPIS display) and comment in the Comments Section. Member Company will verify the Emergency Procedures Message, comment and dispatch time.

6.1.5 Online Test

The Online Test involves the connection of the Member Company's new GMS system to the PJM's RT EMS system. The communications should be accurate and reliable. All systems will be closely watched by the test director over a period of time. During this test, repeat as many steps as possible from the Offline Test above when the new link is brought on line.

6.1.6 Dispatcher Testing Procedure and Computer-to-Computer Testing

Verify Key Control Items on PJM's Displays:

1. PJM will request the Member Company to tel-fail a value for one of their transmission facilities.
2. Check for the appropriate flag on the left side of the PJM Null display and in the status code section of the TAFLA display.
3. PJM will change scheduled frequency (e.g. 59.98 Hz) and verify that the Member Company received the change. PJM will return the frequency signal to normal.

Verify Network Applications

PJM will verify that the State Estimator Application operates properly with the member's equipment included in the PJM Network Model. Specifics of this verification will be based on the overall impact of the member's equipment on the PJM system.

Verify Accounting Data

After confirming connectivity to the customer's metering equipment, PJM will verify the validity and accuracy of individual test data being transmitted. Test data will also be made available from SCADA to Markets Settlements to verify that it is being accurately transmitted.

The generation owner must designate the applicable network model bus(es) at which each revenue meter is to be priced. Once accounting data is successfully being stored in the Market Settlements Database, the generation owner and the Market Settlements staff will compare the accounting data being sent from the generator to the data being received by the PJM settlements system to confirm that it is being transferred accurately.



Verify Real-Time Operational Scheduling

After confirming connectivity, use the Unit Hourly Update page (in eMKT) with the current date to simulate a change in a unit's operational status. PJM will verify that the change was received.

6.2 Training and System Operator Certification

6.2.1 Training

Training of system operators and other operating personnel is essential to promoting reliable operation of the system. Formal PJM sponsored training programs for system operators and others are available on a regularly scheduled basis. Standard PJM system operator training courses include: Initial Training Program (ITP - basic concepts and PJM operating procedures, 4 weeks), Generation MOC Orientation (MOC – generation dispatch procedures, 5 days), and the annual PJM System Operator Seminar (Seminar – updates and refreshers on PJM procedures, 4 days, done 6 times or more yearly).

Key topics in PJM System Operator Training include: normal and emergency operating procedures, data reporting requirements, and other specific procedures for generation and transmission system operators. Other PJM courses for operating personnel are delivered on an “as needed” basis. All PJM training courses are posted on the PJM Web site and available to all PJM members.

6.2.2 PJM System Operator Certification

PJM has instituted a System Operator Certification Program to promote the reliability of the PJM systems. The Certification Program went into effect as of March 1, 2003. The PJM certification program is required of all generation and transmission system operators who operate on the PJM systems are in direct communication with PJM system operators located at any PJM Control Center, and perform daily operations-related functions at the direction of PJM system operators during normal, emergency and/or system restoration states. PJM system operators must also be PJM certified.

System Operators who were operating on the PJM systems on March 1, 2003 had until February 28, 2005 to become PJM Certified. System Operators who begin operating on the PJM systems after March 1, 2003 are allowed two years to become PJM Certified.

PJM System Operator Certification and Training Requirements are documented in PJM Manual 40, entitled Certification and Training Requirements.

Certification Examinations

There are two PJM Certification Exams: one for Generation System Operators and the other for Transmission System Operators. Details are as follows:

System Operators who participate in the real-time operations of the PJM system by dispatching generation resources and performing other generation-related real-time duties of a Market Operation Center (MOC), PJM or PJM West system operator are required to complete and pass the PJM Generation Examination.

System Operators who participate in the real-time operations of the PJM transmission systems and perform other transmission-related real-time duties of a Local Control Center



(LCC), PJM or PJM West system operator are required to complete and pass the PJM Transmission Examination.

For further information go to: <http://www.pjm.com/training/certification/sys-op-cert.aspx>.

6.3 Coordination with Dispatch

6.3.1 Operation

Every Generator interconnected with and synchronized to the transmission system must at all times coordinate operation with PJM and the Local Control Center, providing all necessary and requested information and equipment status, to assure that the electrical system can be operated in a safe and reliable manner.

This coordination includes, but is not limited to:

1. Supplying generator net-MW and MVAR output.
2. Supplying frequency and voltage levels.
3. Scheduling the operation and outages of facilities including providing advanced notification.
4. Coordinating the synchronization and disconnection of the unit with the PJM or local system operator.
5. Providing data required to operate the system and to conduct system studies.
6. Providing documented start-up and shutdown procedures including ramp-up and ramp-down times.
7. Following PJM-directed plant operation during emergency and restoration conditions.
8. Following PJM-directed operation during transmission-constrained conditions.

Note: for Distributed generators modeled at less than 10MW PJM requires the generators to be able to follow PJM direction via SCADA or an agreed upon alternative method.

6.3.2 Communication

To ensure reliable operations and responsiveness, Generators must be properly staffed to support a 7-day, 24-hour contact for communications. Data must be sent to PJM automatically. In the event that the data is temporarily not received by PJM, the Generator Operator must call PJM with the operating data at intervals specified by PJM. The Generator Operator shall correct any problems associated with the failure of equipment within a reasonable time.

The Generator and Local Control Center shall promptly exchange all information relating to all conditions which affect (or could affect) the operations of any facility reporting data.

The Generator shall communicate the outage of any electrical equipment connecting the facility to the PJM system in accordance with these requirements:

1. Each facility will be assigned to one of the PJM Local Control Centers as its primary contact, unless arrangements are made to communicate this information directly to



PJM. This assignment is based upon the voltage level of the connection to the Transmission System and the geographic location of the facility.

2. All planned and maintenance outages of electrical equipment requiring involvement of PJM personnel must be requested by the Generator. The appropriate information must be in a format defined by PJM.

6.3.3 Test Energy

Test energy is energy generated for a predetermined period by a new resource interconnecting with the PJM Balancing Authority for the first time. The test energy period ~~is the time between initial unit start up and the point at which the unit is accepted and made available for commercial operation starts with Stage Two energization (initial synchronization of generator to the transmission system per ICSA).~~ Depending on the size and nature of the generating unit(s), this period may be a matter of hours or days.

Providers of test energy ~~cannot participate in the Day-Ahead Energy Market; however compensation can be obtained at real-time Locational Marginal Prices (LMP) are not required to participate in the Day-Ahead (DA) energy market. Test energy compensation can be obtained at Real-Time (RT) Locational Marginal Price (LMP).~~

Market participation & compensation can only occur if proper metering and modeling are completed as specified in other parts of this manual and the eMeter account is active.

Day-Ahead energy market participation is optional to mitigate RT deviations from DA position.-

Before providing interconnected test energy, Generators must:

1. Have in place an executed Interconnection Service Agreement with PJM.
2. Have in place an executed Interconnection Agreement with Transmission Owner if required by the Transmission Owner.
3. Provide PJM with an accurate Test Schedule, including times and output of unit.
4. Provide notification to PJM Dispatch Operations 30 minutes prior to a change-in-state of each generating unit.
5. Provide the PJM Dispatch Operations and the Market Settlements department accurate information as to when unit will be available for commercial use and in which markets it intends to do business.

If metering is not in place and verified via test, then an eSchedule internal bilateral transaction may be used to support any agreement between the generator owner and the transmission owner. This is an option PJM provides to the parties involved but is not a requirement.

Upon completion of the test period and when the generator is determined to be available for commercial operation, each unit is subject to other voice and data test requirements which are discussed in other sections of this manual.

6.3.4 Other Requirements

The Generator Owner shall develop operating principles and procedures for its facility, coordinated with PJM requirements and provide the necessary training and certification for



appropriate employees. Generators must provide for the necessary communication of information between the Generator and PJM. This information includes:

1. A copy of the Generator's switching procedures
2. Generator data for each generating unit, unit step-up transformer and auxiliary transformer.

Each Generator shall develop operating practices and procedures, coordinated with PJM, for normal and emergency operation and assistance in remedial action. These practices and procedures must incorporate the applicable standards and requirements contained in the PJM Manuals and the NERC Planning and Operating Standards.

Conditions may be encountered on the PJM system, which require participation in remedial action. These include, but are not limited to: actual or contingency flow or voltage-limit violations, violation of synchronous stability limits, low or high frequency, voltage reductions, system blackouts, and maximum and minimum generation conditions.

Each Generator shall immediately notify PJM of any condition that inhibits operating in a reliable manner or in a manner previously agreed upon. Such conditions include, but are not limited to the availability of fuel, inability to operate due to labor restrictions, equipment, environmental, or weather-related problems.

To ensure that all PJM personnel responsible for the design and operation of the PJM system are familiar with equipment configurations, capabilities, and operating parameters, PJM may request, and the Generator shall provide in a timely manner, detailed information about the type, nature, and operating characteristics of the facility and all related equipment.

The Generator must keep and maintain accurate and complete records for Generator interconnection facilities. These records must contain information regarding the operation and maintenance of all equipment and must be consistent with good industry practice. The data in these records must be sufficient for PJM to comply with applicable regulatory requirements. The Generator must make these records available to PJM for inspection and copying as PJM may request.



Section 7: Generator Operations

Welcome to the *Generator Operations* section of the **PJM Manual for Generator Operational Requirements**. In this section you will find the following information:

- Description of the dispatching process (see *Dispatching of Generation*).
- Switching requirements for all equipment a Generator Resource owns, operates or controls (see *Switching Requirements*).
- Generator information and reporting requirements (see *Critical Information and Reporting Requirements*).
- Requirements and procedures for Generator synchronization and disconnect (see *Synchronization and Disconnection Procedures*).

7.1 Dispatching of Generation

7.1.1 Generator Real-Power Control

The Generator must deliver the electric energy generated by the facility to PJM at the point(s) of interconnection in the form of 3 phase, 60-Hertz alternating current at the nominal system voltage at the point of interconnection.

Generators and their protective systems (relaying, V/Hz, etc.), larger than 20 MW, must be capable of operating at a frequency of 57.5 Hz for 5 seconds or longer, or 58.0 Hz for 30 seconds or longer, to coordinate with system preservation under-frequency load shedding. Additionally, generators and their protective systems must be capable of operation at over-frequency up to 62 Hz for a limited duration.

At no time shall the operation of the generating facility, including the associated generators or any of their auxiliary devices, result in an electrical output in which harmonic distortion exceeds the recommended limits contained in IEEE Standard 519, which defines voltage waveform and harmonic content.

The generator shall operate on unrestricted governor control to assist in maintaining interconnection frequency, except for the period immediately before being removed from service and immediately after being placed in service. Governor outages during periods of operations must be kept to a minimum and must be immediately reported to PJM. When a generator governor is not available, the unit output should not fluctuate from pre-scheduled output unless otherwise directed.

System conditions permitting, Generators must respond immediately to a PJM request directing a change in generation output and must proceed at a rate which is within 2% of the generator's stated ramp-rate, until the prescribed output is reached.

7.1.2 Voltage and Reactive Control

General

All Generators must install and have available generator field-excitation regulators. The reactive output of the generator must be regulated in the manner specified by PJM and/or the Local Control Center. An outage of any unit generator voltage regulator, supplementary



excitation control, or power system stabilizers must be communicated to PJM through eDart as far in advance as possible. The Generator Owner must submit these outages.

Voltage control may involve maintaining a predetermined voltage schedule or a reactive generation level. Under normal operations, the Generator shall operate the facility with automatic voltage-regulation equipment in service at all times, except for outages of the regulator for maintenance or equipment failure.

[Generators may elect to operate their AVR in manual mode during startup and synchronization until minimum load is achieved in order to ensure the overall unit stability \(or based upon other physical equipment limitations\) during initial startup and low load operations, however, Generator Owners must notify PJM dispatch if their AVR is anticipated to be in manual mode for more than 30 minutes.](#)

Over-voltage and under-voltage protection systems must be capable of allowing abnormal system operations within PJM post-contingency operating limits. Momentary voltage fluctuations are permitted provided they neither disturb service provided by PJM or the Generator on their respective systems nor hinder PJM from maintaining proper voltage conditions on its system.

PJM has no criterion that exempts generators from compliance with the requirement to:

1. Maintain a voltage or Reactive Power schedule.
2. Comply with the schedule in automatic voltage control mode (AVR in service and controlling voltage).

When notified of the loss of an automatic voltage regulator control, PJM shall direct the Generator Operator to maintain or change either its voltage schedule or its Reactive Power schedule.

During an emergency, the Generator must participate in a voltage reduction declared by PJM and operate the facility at the voltage level requested by the Local Control Center. Unless PJM requests a manual adjustment, the Generator must maintain the facility's automatic voltage regulator(s) in service during an Emergency.

The Generator must notify PJM and the Local Control Center with as much lead-time as possible prior to performing all voltage regulator maintenance. In addition, the Generator shall notify the Local Control Center at least 30 minutes prior to removing or returning the voltage regulator to service. In the event that automatic voltage regulating devices are out-of-service, the Generator shall provide manual voltage regulation to maintain the prescribed voltage schedule or reactive power schedule.

Operations

The Generator, at the option of PJM, shall operate the facility either:

1. According to a predefined voltage schedule provided by PJM (or)
2. According to a reactive power schedule provided by PJM and consistent with the facility's generation capability and the PJM electrical system.

Either schedule must recognize transmission/distribution equipment limits and must be coordinated with the Local Control Center.

When operating to a pre-determined voltage or reactive schedule, the generator reactive output must not violate appropriate pre/post contingency voltage limits.

Additionally, when maintaining a voltage schedule, the generator shall be operated with automatic generator field-excitation regulators in service and must maintain voltage within acceptable bandwidth of the prescribed schedule.

When PJM determines that system conditions warrant a change, the Generator may be requested to deviate from the predetermined voltage or reactive power schedule. PJM may direct a facility to operate in lead, lag, or unity power factor as long as the direction is within the unit's capability.

7.1.3 Generator Operation under Constrained System Conditions

Under normal conditions, each Generator limits its generating output to the value specified in the pre-scheduling information for that hour or to the value directed by the PJM control signal. However, when the system is constrained, PJM may direct the Generator to deviate from these values any time reliability principles and standards are violated.

Where practical, PJM will direct all non-cost measures to be implemented prior to requesting Generators to redispatch. Specific details concerning operation of the transmission system under constrained conditions can be found in the ***PJM Manual for Transmission Operations***.

7.1.4 Generator Operation under Emergency Operating Conditions

Each Generator must limit its generating output to the value specified by its pre-scheduling information for that hour or to the value directed by PJM. PJM has the authority to direct deviation from the pre-scheduled values any time applicable reliability principles and standards are violated.

In order to maintain system reliability during emergency operations, it is critical that Generators respond to directives from PJM. Typical directives are outlined in the PJM Manual for ***Emergency Operations***. Note that these directives may require a Generator to provide additional operational data required by PJM for supplementary system analysis.

In general, a Member's responsibilities during emergency operation include:

- Taking other actions, as requested or directed by PJM, to manage, alleviate, or end an emergency.
- Cooperating with each other and PJM to carry out the emergency procedures and to implement requests and instructions received from PJM for the purpose of managing, alleviating, or ending an emergency.
- Providing notification and other information to governmental agencies as appropriate.
- Collecting, storing, and providing data and other information to PJM to facilitate preparation of reports required by governmental or industry agencies as a result of an Emergency.
- Cooperating and coordinating with PJM and other PJM Members in the restoration of all or parts of the Bulk Electric System in the PJM Balancing Authority.

Additionally, a PJM Generation Owner controlling the output of a Capacity Resource must take or arrange for any or all of the following actions, when directed by PJM, to manage, alleviate or end an emergency:

- Reporting the operating status and fuel situation.



- Canceling testing and maintenance.
- Reducing non-critical plant load.
- Directing personnel to unattended generation sites.
- Starting (including black-start) and loading generation, as directed.
- Reducing output to emergency minimum generation.
- Shutting down generation.
- Interrupting sales for delivery to loads outside the PJM Balancing Authority.
- Selling energy to other Balancing Authorities as requested during emergency conditions in other Balancing Authorities.
- Maintaining records of emergency actions taken and the results achieved.

During an emergency (as determined/declared by the Local Control Center or by PJM) the Generator shall respond as promptly as possible to all directives from the Local Control Center and PJM. These directives may relate to actual or contingency thermal overload of electrical circuits or actual or contingency high/low voltage conditions.

The Local Control Center may also direct the Generator to:

- Increase or decrease the facility energy and/or reactive output
- Connect or disconnect the facility from the PJM electrical system, and/or
- Deviate from the prescribed voltage or reactive schedules.

If safety or system reliability conditions warrant, the Local Control Center may isolate the facility from the PJM electrical system without prior notice to the Generator or upon such notice as is possible under the circumstances. The Local Control Center shall advise the Generator as soon as possible of any forced outages of the PJM electrical system that affect the facility's operations.

The Generator and PJM shall maintain communications and contact during all PJM or Local Control Center emergency operations. When the Local Control Center has determined that the emergency conditions have been alleviated, the Center shall inform the Generator and allow the facility to return to normal operations.

To safely restore the Transmission System following the outage of any facility, the facility isolated from the PJM electrical system shall be allowed to reconnect only under the direction of the Local Control Center or PJM. In all cases, the facility shall be made ready to return to service and provide energy to the PJM system as soon as possible.

Criteria for determining certain emergency conditions are reviewed in the following tables.



Capacity Shortage Procedures			
Condition	Alert	Warning	Initiation
Maximum Emergency Generation Alert	Requested in Operating Plan on prior day.		When demand is greater than highest normal bid.
Primary Reserve	Reserve is less than primary requirement.	Reserve is less than primary requirement but greater than spinning reserve.	
Load Management Curtailment			When generation is not available to meet forecast demand.
Voltage Reduction	Estimated reserve is less than forecast spinning reserve requirement.	Synchronized reserve less than spinning requirement.	When load relief is needed to maintain tie schedules or relieve transmission constraints.
Voluntary Customer Load Curtailment	Forecasted reserve indicates a probable need for this action.		When earlier procedures have not produced needed load relief.
Radio / TV Appeal			When earlier procedures have not produced needed load relief.
Manual Load Dump		Reserves are less than largest contingency.	When earlier procedures have not produced needed load relief.

Exhibit 9: Criteria for Determining Capacity Shortage Emergency Conditions



Light Load Procedures			
Condition	Alert	Warning	Initiation
Minimum Generation Alert	To provide alert that system conditions may require the use of emergency procedures		When expected generation levels are within 1000 MW of normal minimum generation limits
Compile report of Emergency Reducible Generation (ERG)			Prior to Light Load Period
Reduce all units to normal minimum generation			During the Light Load Period
Minimum Generation Emergency Declaration		To notify members further generation reductions are needed to meet the minimum load during the valley period.	At determination of PJM dispatcher
Minimum Generation Event		PJM declares event and requests percentage of ERG as needed (stepped process) to maintain system control	When utilization of ERG is necessary to match the decreasing load
Cancellation			Takes place in reverse order of implementation as PJM load begins to exceed generation and actions taken are no longer necessary

Exhibit 10: Criteria for Determining Light Load Emergency Conditions

7.1.5 Black Start

The LCC must have and maintain the capability and authority to conduct black starts with all generators in the PJM Balancing Authority that are within their respective zones. Voice communication (LCC-to-plant) tolerant of major power system failures is the minimum requirement to achieve black start. Private communication systems on un-interruptible power supplies (UPS) and radio systems are examples of this type of system. The current satellite-phone voice communication from PJM to the LCCs meets the minimum requirements for PJM-to-LCC communication. The current PJM approach of communicating directly through the satellite (avoiding the ground station) is designed to be tolerant of major power system failures. Black Start units operators shall not permit their fuel inventory for Critical Black Start CTs to fall below 10 hours – if it falls below this level, unit operators shall notify PJM and place the unit in Max Emergency.

Specific details concerning procedures that the PJM OI follows to ensure, monitor, and perform accounting for Black Start Service can be found in the ***PJM Manuals for Pre-***



Scheduling Operations, Balancing Operations, and Open Access Transmission Tariff Accounting.

7.2 Switching Requirements

A Generator is responsible for switching all equipment it owns, operates, or controls. A trained person must be available within a maximum of two hour's notice for the purposes of performing switching. Specified devices isolating the facility from the Transmission System shall be switched by the Generator or the Local Control Center (according to the configuration and contract) whenever requested by PJM. These devices must be locked if applicable and tagged to provide adequate safety.

The Generator's switching procedures shall at all times be followed precisely by the Generator and be closely coordinated between the Generator and the Local Control Center. Either party (Generator or LCC) must provide a written copy of in-effect switching procedures to the other party upon request.

If requested by the Generator, specified Local Control Center devices shall be operated and tagged by the Local Control Center according to the Local Control Center's switching and tagging practices and safety rules. Local Control Center switching and tagging practices and safety rules shall apply to all situations involving the Local Control Center and any Generator personnel involved with Local Control Center switching and tagging.

7.3 Critical Information and Reporting Requirements

PJM is responsible for coordinating and approving requests for necessary outages of generation and transmission facilities. This assures the reliable operation of the PJM Balancing Authority. PJM maintains records of outages and outage requests for these facilities.

The procedure begins when a designated resource owner and/or an entity acting on their behalf submits an outage request via eDART. The outage request is recorded electronically and can be accepted or rejected by the PJM Dispatcher. Refer to the PJM Manual for ***Pre-Scheduling Operations*** for information on the outage request procedure and request tracking via eDART.

It is important to emphasize that PJM does not schedule or determine when outages should take place. PJM only accepts or rejects the requests for outages submitted by Members. It is the responsibility of each Generator to determine its own best schedule of outages.

Outage requests are honored by PJM on a first come-first served basis. Requests are rejected only when they affect the reliability of the PJM Balancing Authority.

7.3.1 Planned Outage

The Generator shall provide PJM with written notice of its intent at least thirty days prior to performing planned maintenance of the facility, including turbine, generator, and boiler overhauls or inspections, testing, nuclear refueling, etc.

When feasible, the Generator shall provide PJM with written notice of its intent at least thirty days prior to testing protective apparatus associated with generator interconnection facilities, including circuit breakers, relays and auxiliary equipment. PJM personnel or designated Local Control Center personnel may observe such testing.



The Generator shall notify PJM and the Local Control Center of its intent to remove electrical equipment from service by 10:00 a.m., three working days prior to the planned maintenance outage begins.

An additional notification to PJM and the Local Control Center is required 30 minutes before the planned outage begins.

The Local Control Center may request the Generator to delay or reschedule the planned maintenance outage if system-reliability conditions warrant.

To the extent practical, PJM will provide to the Generator advance notice of PJM's intention to perform planned maintenance on reportable PJM facilities that may affect the Generator's operations.

7.3.2 Maintenance Outage

A maintenance outage is an outage that may be deferred beyond the next weekend but requires that the Capacity Resource be removed from service before the next planned outage. Characteristically, these outages may occur throughout the year, have flexible start dates, are much shorter than planned outages, and have a predetermined duration established at the start of the outage.

7.3.3 Unplanned Outage

The Generator may not remove any equipment from service without prior notification to PJM and/or the Local Control Center (LCC) except in the case where equipment must be disconnected from the system without PJM approval to prevent injury to personnel or damage to equipment.

However, if the Generator has any advanced knowledge of an unplanned outage, the Generator shall notify the LCC with as much lead-time as practical. For reliability reasons, the Generator shall notify the LCC as soon as reasonably possible of the following:

- The starting time of the unplanned outage.
- The energy reduction resulting (or expected to result) from the unplanned outage.
- The estimated time the equipment incurring the unplanned outage is expected to return to service.
- The time the Generator equipment is actually returned to service.
- The reason for the outage.

The Generator must submit a record of the events and circumstances giving rise to the unplanned or forced outage to PJM as soon as reasonably possible. The Generator must also notify PJM of any unusual operating conditions which may result in the reduction of output or tripping of multiple generators offline.

In addition, the Generator must notify PJM of any system conditions, whether a result of equipment failure or mandated restrictions (plant, governmental, etc.), which may result in potential generation reduction or controlled shutdown of any generator.

Additional details regarding Planned, Maintenance, and Unplanned outages can be found in the ***PJM Manual for Pre-Scheduling Operations***.

7.3.4 Generating Unit Reactive Capability Reporting

Generating Unit Reactive Power is a primary method of providing voltage support on the PJM system. A lack of deliverable Generating Unit Reactive Power, which is relied upon to be available based on reported Reactive Capability, can result in PJM system reliability problems including voltage collapse. Whereas, proper reporting can result in controlled measures, such as generation adjustment in lieu of unanticipated load shedding to address inadequate Reactive Power Reserves.

Generating Unit Reactive Capability is a measurement of the reactive power able to be delivered by a generating unit to the transmission system. It is defined by the MW versus MVAR points of a generator capability curve. To help maintain a reliable transmission system, each Generation Owner/Operator must provide capability curve information to PJM via eDART as soon as the information is available. The Local Control Center for the Transmission Zone where the unit is located will be automatically notified via eDART, as well as any other Local Control Centers with eDART authority to receive automatic notification for the unit. For real-time changes, each Generation Owner should also notify PJM and the respective LCC via phone. "Continuous Unit Reactive Capability Curve" data must be provided as follows via eDART:

- *Continuous Unit Reactive Capability Curve (required to provide)* - data that provides the realistic usable reactive output that a generating unit is capable of delivering to the PJM Interconnection and sustaining over the steady state operating range of the unit.

The PJM EMS Real-Time and Study Network Applications, Seasonal PJM Operating Studies, and PJM Planning Studies use Continuous Unit Reactive Capability Curves for actual pre-contingency steady-state analysis and for simulated post-contingency security analysis.

The Generator Operator shall notify PJM as soon as practical, but within 30 minutes of any temporal unit performance issues, including reactive capability derates or status or capability change on any generator Reactive Power resource, such as the status of each automatic voltage regulator and power system stabilizer and the expected duration of the change in status or capability and a status or capability change on any other Reactive Power resources under the Generator Operator's control and the expected duration of the change in status or capability.

The Generating Unit Reactive Capability determination should reflect planned unit modifications and real-time limitations caused by system voltages, unit transformer tap position setting, temperature, operating conditions and restrictions, station auxiliary equipment, generator terminal bus voltage limitations, and auxiliary bus voltages limitations. There may be different limiting conditions for either leading or lagging reactive capability.

Planned modifications (tap changer adjustment, GSU replacements, turbine modification, etc) that impact generator reactive capability should be communicated to the impacted TO and PJM as far in advance as possible but no later than the return of the unit from the planned maintenance or scheduled adjustment. Changes should be communicated via eDart.

To ensure accuracy of generator reactive capabilities that may result from planned unit modifications, a critical input to PJM and Transmission Owner security analysis packages, PJM requires that each Generation Owner/Operator review and confirm their unit reactive



capability data via eDART on a bi-annual basis. PJM and the Transmission Owners should then verify accuracy of unit reactive capabilities modeled in their respective EMS systems. The bi-annual review periods are defined as follows:

- Pre-Summer Review: From April 1 through April 30, Generator Owners should review their unit reactive capabilities in eDART. From May 1 through May 31, PJM and Transmission Owners should review and update EMS reactive capabilities based on the updated data in eDART.
- Pre-Winter Review: From October 1 through October 31, Generator Owners should review their unit reactive capabilities in eDART. From November 1 through November 30, PJM and Transmission Owners should review and update EMS reactive capabilities based on the updated data in eDART.

See Attachment D for a detailed description of the PJM Generating Unit Reactive Capability Curve Specification and an explanation of the PJM Reactive Capability Reporting Procedures.

A reactive test shall be performed as soon as practical following any planned upgrades which impact a unit's reactive capability. Estimated or calculated data reactive capability data (D-Curve) must be provided as an interim measure until a reactive test can be performed.

Effective February 1st, 2005, PJM requires periodic verification of reactive capability via real-time testing. See Attachment E for a detailed description of the PJM requirements for Generator Reactive Capability Testing. In addition, see Attachment F for detailed procedures on scheduling and conducting reactive tests.

7.3.5 Fuel Limitation Reporting

Background and Intent

PJM needs data concerning unit fuel reserves for it to reliably operate the PJM Balancing Authority and its associated markets. This is especially true during periods of severe weather and/or times when there are external fuel constraints (i.e., coal strike, oil embargo). During PJM's last capacity driven load dump situation (Winter Freeze, 1994) the fuels data provided by PJM's members reduced the severity and duration of actual load curtailments.

It is the intent of this procedure to require all capacity resources to report fuel data so that in severe situations, PJM can continue to make the calls that are in the best interest of all its members. In contrast with past procedures, where PJM could have used this data to restrict the output of various generators based upon their fuel limitations without financial compensation, PJM will now use the information to assist the market in providing solutions to emergency situations.

PJM's authority to require all capacity resource owners to provide these reliability based reports is found in the PJM Operating Agreement (11.3 Member Responsibilities; 11.3.1 General; 1.10 Emergency, line ii) and in the "good utility practices" of NERC Policy 6 (Section B, Emergency Operations, Guides 1 and 2.2).

Seasonal Reporting

Prior to going into the winter season, PJM will notify and request from all members with capacity resources, by unit report of fuel information. Additionally this information may be



requested at other intervals as deemed necessary such as a fuel crisis (i.e., embargo, strike) or forecasted period of severe cold weather.

An electronic spreadsheet will be sent to participants indicating required data (see Sample Fuel Baseline Data exhibit below). The required data will include information such as each unit's:

- available primary fuel
- available secondary fuel
- projected fuel inventory (in terms of MWh)
- typical fuel inventory (in terms of MWh)
- average amounts of fuel per delivery
- delivery frequency
- amount of firm gas schedules

While some of this data may represent broad projections, it will assist in providing a baseline that can be compared to data submitted in the real-time reporting process to assist in determining the severity of specific emergency conditions.

Fuel Baseline Data													DATE:	1/30/01	
Company	Plant Name	Unit	Winter (KW)	Primary Fuel Type	Transport Method	Alternate Fuel Type	Transport Method	Primary Fuel Availability (MW-Hours)	Primary Average Fuel Availability (MW-Hours)	Alternate Fuel Availability (MW-Hours)	Alternate Average Fuel Availability (MW-Hours)	Gas Schedules (% of Firm)	Average Delivery Amount	Delivery Frequency	Comments
Company A	Unit 1	GT	7,000	NG	PL	NR	TR	1200	1400	670	470	37%	35	3DAY	
Company A	Unit 2	ST	10,000	FO6	RR			2000	1800				60	5DAY	

Exhibit 11: Sample Data (Fuel Baseline)

Real-Time Reporting

When PJM receives a severe cold weather forecast or foresees a potential fuel crisis (i.e. embargo, strike), real-time updates of fuel limited units will be requested of members via Part G of the Supplementary Status Report (see *Attachment A of PJM Manual for Emergency Operations*). This data will also be reported in other situations when a Supplementary Status Reports is requested, such as Capacity Shortage emergencies.

A unit is considered fuel limited when it is not capable at running at its maximum capacity for the next 72 hours. If a unit has an alternate fuel which would allow it to run at its maximum capacity for more than 72 hours, it does not need to be reported. However, if switching fuels involves a shut down and introduces the risk of the unit not being able to re-start after the switch, the unit should be reported if its primary fuel supply would produce less than 72 hours of runtime at maximum capacity. Besides fuel, the limitation of other resources, such as water, may also restrict the amount of time a unit will be able to operate. If a unit has less than 72 hours of run time at maximum capacity due to any resource limitation, it along with any fuel limited units should be reported in Part G, "Resource Limited Units," of the Supplementary Status Report (see Attachment C of *PJM Manual for Emergency Operations*). The following information should be included:



- Unit Name—The name of the unit(s) (units with shared resource supplies should be listed together) that are considered resource limited.
- Fuel type
- Maximum Capacity—The current maximum capacity of the unit(s).
- Emergency Minimum—If a unit cannot cycle due to uncertainty of starting up again, Emergency Minimum must be included with a note in the Comments section.
- Current Energy—Current MW output.
- Total Burn Hours Remaining—Total burn hours remaining with unit at max capacity.
- Comments—If a unit is limited for a resource other the fuel, this should be noted in this column as well as any other pertinent information on the unit.

In addition to unit information submitted to PJM via Part G of the SSR, members should also monitor fuel inventories for the following minimum levels:

- CTs or Diesels—Less than or equal to 16 hours at maximum capacity
- Steam—Less than or equal to 32 hours at maximum capacity

In the event the above levels are reached, generation owners must immediately report this to the PJM Scheduling Coordinator (610) 666-8809.

PJM's Use for Fuels Data

PJM uses the fuel data in conjunction with the other data reported in the SSR to evaluate system conditions. Reports such as the PJM System Status Report (see Attachment C of the **PJM Manual for Emergency Operations**) are compiled. Some portions of the reports are posted electronically via the internet or faxed to members so all members can assess the severity of the impending weather and available generation capacity. Additionally reports derived from this information are used to lead strategy discussions among SOS members about the criticality of the situation and to determine the timing of various emergency procedures that may be used.

An invitation may also be posted to other members to attend a PJM SOS conference call to discuss the meaning of this data and how it may result in various emergency procedures.

At no time in any of these communications or discussions will individual units or company's data be distributed or divulged. PJM will treat this information with the greatest degree of confidentiality. Discussions on individual units or company's fuel status will only occur between PJM and the generation owners who provided the data. During group discussions, PJM will only discuss what possible emergency actions are foreseen or what aggregate fuel crisis exists.

Unit specific Fuel Limitation Information is considered proprietary and confidential, and will not be distributed amongst participants. Only aggregate information will be discussed for the sole purpose of developing reliable operating strategies during projected capacity deficient conditions.



Operation of Fuel Limited Units

PJM requests companies that have units classified as fuel or resource limited units to bid these units in the Max Emergency category. This will serve to preserve these resources for the times when they are needed most. If a unit bid into PJM has resources of less than 32 hours (at maximum capacity) for a steam unit or 16 hours (at maximum capacity) for a CT or Diesel, and PJM has issued a Cold or Hot Weather Alert, then the unit must be bid in the Max Emergency category.

PJM will continue to schedule system generation based upon the Two Pass methodology and generator owner's individual bids. If PJM has particular concerns over units deemed critical to current or future system conditions, then PJM will initiate individual communications with the members responsible for those units.

If PJM asks a unit to operate differently than what was accepted in the day-ahead market (in order to conserve the unit's current fuel), then this unit would be paid its lost opportunity cost for the accepted hours that it was not run. (Reference Operating Agreement, section 3.2.3, (e), (f)).

7.4 Synchronization and Disconnection Procedures

The Generator must obtain prior approval from PJM when synchronizing the facility to, or disconnecting the facility from, the PJM electrical system. In addition, the Local Control Center must be notified when synchronizing or disconnecting from the Transmission Owner's system. The only exception is when equipment must be disconnected from the system without PJM approval to prevent injury to personnel or damage to equipment. If the disconnection occurs without prior PJM approval, the Generator shall immediately notify the Local Control Center as to the cause, energy reduction, and the expected return time.

The Generator must keep the LCC and PJM dispatchers informed at all times of the facility's availability or any change in status. Additional requirements appear in the PJM Manuals for Pre-Scheduling Operations, Scheduling Operations, Balancing Operations, and Control Center and Data Exchange Requirements.

The facility shall normally be operated with all of the Generator's protective relays (primary or back-up) in service whenever the facility is connected to, or operating in parallel with, the PJM electric system. The facility may operate for a limited time to perform maintenance with one set of redundant relaying in service. PJM and the Local Control Center shall be notified of such occurrences.



Section 8: Wind Farms Requirements

Welcome to the Wind Farms Requirements section of the *PJM Manual for Generator Operational Requirements*. In this section you will find the following information:

- Description of Wind Farms data requirements.
- Description of PJM Wind Power Forecasting service.

8.1 Computer System Data Exchange

The PJM SCADA system allows PJM to communicate directly with individual generators or smaller Control Centers. A data concentrator (e.g. Remote Terminal Unit, Generator Control System, etc.) is located at the Member's site, and, after collecting data from the industrial metering equipment, communicates with PJM's SCADA system using either DNP 3.0, Level 2 (Distributed Network Protocol) or ICCP (Inter-Control Center Protocol) consistent with PJM Control Center Requirements Manual (M01).

Every Generator interconnected with and synchronized to the transmission system must at all times coordinate operation with PJM and the Local Control Center, providing all necessary and requested information and equipment status, to assure that the electrical system can be operated in a safe and reliable manner. Attachment L defines coordination models that are considered acceptable PJM Wind Farm Communication Models.

This coordination includes, but is not limited to:

- Supplying low side generator net-MW and MVAR output.
- Supplying meteorological data (wind speed, wind direction, temperature, pressure and humidity). Wind speed and direction required.
- Scheduling the operation and outages of facilities including providing advanced notification.
- Coordinating the synchronization and disconnection of the Wind Farm with PJM and Transmission Owner.
- Providing data required to operate the system and to conduct system studies.
- Providing documented start-up and shutdown procedures including ramp-up and ramp-down times.
- Following PJM-directed plant operation during emergency and restoration conditions.
- Following PJM-directed operation during transmission-constrained conditions.

All data items, regardless of type, are collected and disseminated at a frequency of 10 seconds or less.

Each PJM Member is responsible for determining data-quality indicators for all data transmitted to PJM. Both failed individual values and any value calculated using a failed point must be flagged. When a point fails for an extended period, a manual update of the point's value may be necessary to keep the data as accurate as possible. The Generator shall communicate the outage of any data communication equipment connecting the facility to PJM Dispatch.

8.2 Wind Farm Data Requirement for Wind Power Forecasting

PJM Wind Power Forecaster has been selected through competitive process between several National and International Vendor's. It has been determined through the learning process that the Wind Power Forecaster requires several data points from the wind farms to accurately forecast the wind power. The following are the data requirements for wind farms:

8.2.1 Initial Data Requirements

The Wind Farms are required to provide the following data points for each turbine as part of their initial set up so they can be properly modeled within the Wind Power Forecasting Tool.

- General Turbine Information
 - Class of turbine
 - Capacity of turbine
 - Power Generation Threshold Rates (i.e. minimum / maximum wind speed)
- Manufacture Power Curves of individual wind turbines
- Geographic location (longitude and latitude) of wind farm site or each turbine if available.
- Hub height of wind power facility
- Aggregate Historic data (measured MW output, outage information, and wind speed at hub height) for existing facilities that connect to PJM Transmission or bid into the PJM market.
- Ambient Temperature Operating Limits and information regarding installation of -old weather packages" to increase thermal limit capabilities during extreme cold weather conditions.

Note: Aggregate Reactive Capability Curve (D-Curve) required ensuring accuracy of Security Analysis Results.

8.2.2 Aggregate Real Time Output

The Wind Farms are required to provide the real time aggregate Wind Farm MW output along with other data points. This output should be telemetered at low-side net and high side-net of the Wind Farm.

8.2.3 Real Time Meteorological Tower (or mutually agreed upon alternative source)

The Wind Power Forecasting accuracy is highly dependent on the availability of the real time meteorological tower data for tuning the forecaster model. Each wind farm must install at least one meteorological tower (or wind speed and direction from selected turbines' anemometer and wind vane) in the farm and provide real time meteorological data to PJM through ICCP or DNP 3.0, Level 2 link. Depending upon the topology and the accuracy of the Wind Power Forecast, PJM may request addition of more meteorological towers at a Wind Farm site.



The height of the meteorological tower should be same or close to the hub height of the wind turbine. The generation owner should calibrate and check the accuracy of the met tower every year as per standard.

The meteorological data shall include the following parameters:

Parameter	Units	
Wind Speed	meters/second	Required
Wind Direction	Degree from True North	Required
Temperature	Fahrenheit	Preferred
Pressure	Hectopascals	Preferred
Humidity	percent	Accepted

8.2.4 Generator Outage Reporting (Aggregate Turbine availability)

PJM is responsible for coordinating and approving requests for outages of generation and transmission facilities, as necessary, for the reliable operation of the PJM RTO. PJM maintains records of outages and outage requests for these facilities.

The electronic Dispatcher Application and Reporting Tool (eDART) provides communication with PJM for generation operators regarding unit outage requests, updates to reactive capability curves (D-curves), and AVR statuses. Additional applications may be integrated in eDART in the future. User registration is available from the PJM Web site.

In eDart, a Wind Farm is modeled as a single unit with a capability equal to the sum of all turbines at full output. Wind Farm aggregate turbine outage/derate information is required to validate and enhance the accuracy of the Wind Power Forecast. Generation Owners should not provide outage tickets related to wind speed since specific turbine parameters will be modeled within the forecast tool.

See the PJM Manual for Pre-Scheduling Operations (Manual 10) Section 2 Outage Reporting for the generation outages reporting.

Note: Due to the impact of planned/unplanned turbine outages on wind power forecast accuracy, wind resources shall report any outage of one megawatt or more with duration of one hour or longer. Outages shall be submitted on aggregate plant capacity by outage type.

8.2.5 Grid Capacity Limit (Constraints or Economic Curtailments)

PJM is responsible for capturing congestion and economic curtailment directives and providing the data as inputs into the Wind Power Forecasting Tool.

8.2.6 Wind Power Forecast

PJM will collect the wind turbine/farm locations' real-time aggregate power output and meteorological data from the Wind Farms. The data will then be sent to the Wind Power Forecaster along with Wind Farm curtailment/outage information. All data shared with the Wind Power Forecast vendor is treated as confidential. The Wind Power Forecaster will collect all of the data from PJM and other outside sources, such as global and regional



weather forecasts, and after processing the data will send PJM the Wind Power Forecast and all associated data for the individual or aggregate Wind Farms as designated by PJM.

PJM does four different types of forecasts for each individual or aggregate Wind Farm. All the examples consider the current time to be T.

1. Short Term Forecast (T + 6): Update Wind Power Forecast with a frequency of every ten minutes and forecast interval of five minutes for the next six hours (6) for the individual or aggregate Wind Farms as designated by PJM.
2. Medium Term Forecast ((T + 6) + 42): Update Wind Power Forecast with a frequency and interval of every hour for the next forty two hours (42) for the individual or aggregate Wind Farms as designated by PJM.
3. Long Term Forecast ((T + 6) + 42) + 120): Update Wind Power Forecast with a frequency and interval of every hour for the next one hundred twenty hours (120) for the individual or aggregate Wind Farms as designated by PJM.
4. Ramp Forecast: (T + 6): Update Wind Power Ramp Forecast with a frequency of every ten minutes and forecast interval of five minutes for the next six hours (6) for the individual or aggregate Wind Farms as designated by PJM.

8.3 Forecast Data Usage

8.3.1 Real-time Reliability Assessment

PJM will use the Short-Term Wind Power Forecast to evaluate current day congestion and to ensure that sufficient generation resources are available to respond to real-time or projected fluctuations in Wind Power Output.

8.3.2 Day-ahead Reliability Assessment

PJM will use the Medium-Term Wind Power Forecast to predict day-ahead congestion and mitigating strategies and to ensure that sufficient generation resources are scheduled within PJM to meet forecast load, transaction schedules and PJM reserve requirements. PJM may choose to use the updated version of the day-ahead Wind Power Forecast provided by the forecaster after 1700 hours and before 1800 hours.

The Long-Term Wind Power Forecast may be used to analyze weekend or long holiday conditions.



Section 9: Generator Deactivations

Welcome to the *Generator Deactivations* section of the **PJM Manual for Generator Operational Requirements**. In this section you will find the following information:

- Description of the PJM deactivation process (see *Generator Deactivation Process*).
- Methodology for compensation to Generators required to remain in service for reliability (see *Compensation to Generators Requested to Remain in Service for Reliability*).
- An exhibit showing the process flow diagram for generator deactivation.

9.1 Generator Deactivation Process

This section reviews the steps and timeline for the PJM generator deactivation process, and the potential results of the process. This section also reviews the methodology of compensation to generators requested to remain in service for reliability.

9.1.1 Generator Deactivation Request

Any generator owner, or designated agent, who wishes to retire a unit from PJM operations must initiate a deactivation request in writing to the PJM Power System Coordination Manager no less than 90 days in advance of the planned deactivation date. Black start resources require up to 2 years advanced notice to maintain the rolling 2-year commitment per the PJM Tariff. This notice will include, at a minimum, the following information:

- Indication of whether the unit is being retired or mothballed;
- The desired date of deactivation;
- A good faith estimate of the amount of a project investment and the time period the generator would be required to be out of service for repairs, if any, that would be required to keep the unit in or return the unit to operation.

PJM Power System Coordination Department will notify PJM Planning, PJM Markets and the PJM Market Monitoring Unit. PJM will also notify the appropriate transmission owner(s) of the request with the agreement of the generation owner or designated agent. PJM will initiate preliminary analysis of the request.

Note that only official requests to deactivate a unit are subject to the following procedures and timelines. All official requests are subject to public posting on the PJM Web site. Any requests to analyze potential retirements will be treated as unofficial requests, and the PJM deactivation process will not begin until an official public request is received.

9.1.2 Initial Analysis

PJM Planning will perform an initial analysis of the request. PJM Planning will perform standard RTEP/MAAC analysis for the affected summer peaks. PJM Planning will also identify maintenance and appropriate sensitivity analyses to be performed in addition to standard tests. PJM will review planned system reserve levels and conduct appropriate deliverability analysis. In addition, the PJM Market Monitoring Unit will analyze the effects of the proposed deactivation with regard to potential market power issues.



9.1.3 Analysis Results

The initial analysis has the following potential outcomes: (1) No reliability or market power issue identified, (2) Reliability or market power issue identified, or (3) Economic or congestion impact identified (PJM identifies potential for additional congestion due to the deactivation).

No Reliability or Market Power Issue Identified

- If no reliability or market power issue identified, the generator can retire as soon as practicable.
- Black start resources will forfeit a maximum of 1 year of revenues per existing tariff. If the unit is a black start resource, PJM will identify feasible alternative sites, and request tariff based bids to replace black start. A bid to re-power (improve) existing resource will be considered. The lowest cost replacement black start resource will be selected.

Reliability or Market Power Issue Identified

- PJM will notify the generator owner, or its designated agent, within 30 days of the deactivation request if a reliability issue has been identified. This notice will include the specific reliability impact resulting from the proposed deactivation of the unit, as well as an initial estimate of the period of time it will take to complete the Transmission upgrades necessary to alleviate reliability impact
- Within 60 days of the original deactivation request, the generator owner or designated agent, will provide PJM with an update estimate of any project cost and the period of time for which the unit would be required to be out of service for repairs, if any, that would be required to keep the unit in, or return the unit to, operation.
- Within 75 days of the original deactivation request, PJM will provide an updated estimate of the period of time it will take to complete the Transmission upgrades necessary to alleviate reliability impact
- Within 90 days of initial deactivation request, PJM will inform the generator owner, or designated agent, and post on its web site full details of the transmission upgrades that will be required in order to allow the unit to deactivate.
- Black start resources will forfeit a maximum of 1 year of revenues per existing tariff. If the unit is a black start resource, PJM will identify feasible alternative sites, and request tariff based bids to replace black start. A bid to re-power (improve) existing resource will be considered. The lowest cost replacement black start resource will be selected.

Economic or Congestion Impact Identified

- If PJM identifies an economic or congestion impact (e.g., potential for additional congestion due to the deactivation), the generator can retire as soon as practicable.
- Black start resources will forfeit a maximum of 1 year of revenues per existing tariff. If the unit is a black start resource, PJM will identify feasible alternative sites, and request tariff based bids to replace black start. A bid to re-power (improve) existing resource will be considered. The lowest cost replacement black start resource will be selected.



- Any economic impacts will be analyzed through the existing FERC approved economic planning process.

9.2 Compensation to Generators Requested to Remain in Service for Reliability

Upon receipt of notification from PJM that a generating unit will be requested to operate past its desired deactivation date, the generator owner may file with FERC for full cost recovery associated with operating the unit until it may be deactivated. The cost calculations may be reviewed with PJM prior to filing at the election of the generation owner.

In the alternative, the generator owner, or its designated agent, may choose to receive avoided cost compensation according to the Deactivation Avoidable Cost Credit in Part V of the PJM Tariff. Avoidable expenses are incremental expenses directly required for the operations of a unit proposed for deactivation. The two major components to the avoid cost formula contained in the Tariff are:

- Categories of costs that are avoidable expenses
- Limited amount for necessary investment to keep unit in operable condition

Avoidable expenses do not include variable costs recoverable under cost-based offers to sell energy in PJM Interchange Energy Market. Additional investment over and above the limited component in the avoided cost formula must be filed as a separate rate. All inquiries regarding avoidable expenses are to be directed to the PJM Market Monitor

If the generation owner, or designated agent, chooses the compensation according to the Deactivation Avoidable Cost Credit in Part V of the PJM Tariff, compensation to the generator will begin as of the day following the filing, and will be net of revenues from the PJM markets. All revenues from the PJM markets and unit-specific bilateral contracts will be net of marginal cost of service recoverable under cost-based offers to sell energy from operating capacity of the PJM Interchange Energy market, not less than zero

- A 10% adder will initially be applied to the avoidable costs, and this adder will increase in future years. Applicable adders for future years are detailed and defined in Part V of the PJM Tariff.

Costs (avoidable cost rate minus net revenues) will be allocated as an additional transmission charge to the zone(s) for which the Transmission Owner(s) will be assigned the cost of the transmission upgrade.

If a generation owner, or designated agent, chooses to file for full cost of service with FERC, PJM begins crediting the generator the amount approved by FERC, on the timeline ordered by FERC as part of the approval. PJM also allocates the costs associated with these credits according to FERC order.

The following exhibit displays the generation deactivation process flow.

Generation Deactivation Process Flow

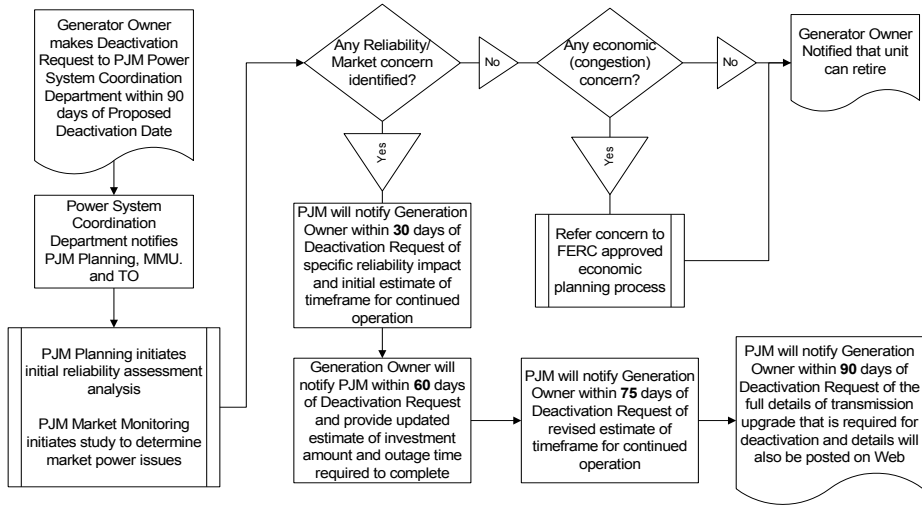

Exhibit 12: Generation Deactivation Process Flow



Section 10: Black Start Replacement Process

Welcome to the *Black Start Replacement Process* section of the **PJM Manual for Generator Operational Requirements**. In this section you will find the following information:

- Description of the PJM black start replacement process.
- Process flow diagram for black start replacement.
- Description of cost-based components for black start replacement bids (see *Cost-Based Components for Black Start Replacement*).

10.1 Black Start Replacement Process

The following business process is defined for replacement of critical black start units in PJM when a Black Start Generator Owner (GO) that terminates its commitment to provide black start service. Portions of this Black Start Replacement Process may also be initiated to request new black start resources due to any of the following events:

- The Transmission Owner identifies new or changed black start needs as a result of a review of its restoration plan.
- The Transmission Owner (TO) exercises its right to terminate the two-year commitment to a black start resource by providing notice of termination one year before the date the commitment period ends, in accordance with Schedule 6A of the PJM OATT.
- PJM terminates a Black Start Unit's designation as critical (e.g., due to reliability concerns, performance issues, or due to changes to its restoration plan) by providing two years prior notice of such termination in accordance with Schedule 6A of the PJM OATT.

10.1.1 Initial Black Start Commitment

Generators commit initially for at least two years to provide black start service from the black start service implementation date, with an annual right to terminate by each party (the generator owner and the transmission owner) with one year's notice. In the event that neither the Black Start Generator Owner (GO) nor the Transmission Owner (TO) exercises its right to terminate by providing a one year notice of termination, the commitment to provide Black Start Service automatically will be extended for an additional year to maintain a rolling two-year commitment.

In the event that a Black Start Unit fails to fulfill or chooses to deactivate or withdraw from black start service prior to its two year rolling commitment to provide Black Start Service, the Black Start Unit owner shall forfeit the received monthly Black Start Service revenues for the period of its non-performance not to exceed revenues for a maximum of one year.

10.1.2 Replacement Process Step 1

Upon receiving a request from a GO to deactivate a black start unit or otherwise withdraw from providing black start service, PJM will notify the TO.

Timeline: Within 5 business days from receipt of the termination request.



10.1.3 Replacement Process Step 2

PJM will discuss with the TO to identify feasible sites that meet the location and capability requirements for replacing the black start resource.

Timeline: Within 15 business days of receiving the termination.

10.1.4 Replacement Process Step 3

If PJM and the TO determine that there is sufficient redundancy of black start resources in the region, consistent with the minimum critical black start requirement defined in Attachment A of PJM Manual M-36 on System Restoration, such that there is no need to replace the withdrawing or deactivating black start unit in the restoration plan, PJM will initiate a final review and approval through the SOS-T committee of the TO's restoration plan and advise the TO whether such plan is adequate without a replacement black start unit.

In the event that PJM and the TO do not agree on whether there is a need to replace the withdrawing or deactivating black start unit in the restoration plan, PJM will initiate a review with SOS-T for additional technical assessment, and if after the SOS evaluation, an agreement is not yet achieved, the PJM Dispute Resolution process will be employed. Please refer to Section 5 of the ***PJM Manual for Administrative Services for the PJM Interconnection Agreement*** for more details about the PJM Dispute Resolution process.

Timeline: Within 30 calendar days of receiving the termination request.

10.1.5 Replacement Process Step 4

If PJM and the TO determine that there is a need to replace the withdrawing or deactivating black start resource, PJM will seek for replacement of the retiring black start resource using the process below.

Timeline: Within 30 calendar days of receiving the termination request.

- A. After PJM and the TO determine that there is a need to replace the deactivating or withdrawing black start resource in order to meet the defined minimum critical black start zonal requirement, and also determine the location and capability requirements, PJM will post online a notification about the need for a new black start resource along with the location and capability requirements. Please refer to Attachment A of the ***PJM Manual for System Restoration*** for more details on the selection criteria for replacement black start resources. This notification will also advise that all bids submitted for the replacement black start resource must be cost-based bids consistent with Schedule 6A of the PJM OATT. Details of the required cost components for each prospective black start replacement bid are provided in the following subsection on *Cost-Based Components for Black Start Replacement*.
- B. This posting should be made within 30 calendar days of receiving a request to terminate the existing black start resource, and will mark the beginning of a "Market Window" which will last 90 calendar days from the date of the notification. The posting will also advise that PJM will be reviewing pending generator interconnection projects and other projects that are received within the Market Window.



- C. PJM will review each Generation Interconnection Request pending under Part IV of the PJM Tariff at the time a Market Window is opened (as described above) and each request from Black Start Units and each Interconnection Request it receives during such Market Window, to evaluate whether the project proposed in the request could meet the black start replacement criteria for which the Market Window was established.
- D. The TO will also have the option of negotiating a cost based bi-lateral contract in accordance with the existing process outlined in Schedule 6A of the PJM OATT with a generator owner for black start services. The TO may provide the alternative as one of the bids for the black start replacement that will be evaluated by PJM in step 4E pending FERC approval.
- E. If PJM and the TO determines that more than one of the proposed projects within the 90 day market window meets the replacement criteria, the most cost-effective resource for the black start replacement will be chosen, provided the identified resource accepts and maintains designation as a market solution under Sections 36A or 41A of the PJM Tariff and executes the agreement(s) required thereunder. Submitted projects costs must be consistent with Schedule 6A of the PJM OATT

If no projects are received during the 90-day market window, PJM and the TO will revisit step 4A, and modify the location and capability requirements for the replacement black start resource, as well as the market window, if necessary, to allow more resources to become viable as replacements, even if sub-optimal.

If no projects are identified after the modified search criteria and market window, PJM and the TO will investigate the cause for the absence of bids, and recommend corrective action in accordance with the existing cost-based service process outlined in Schedule 6A of the PJM OATT, or address other barriers to entry identified by such investigation within the bounds of the existing tariff. In the process of this investigation, PJM will also identify limits for adjusting the cost of entry and other corrective actions within the bounds of Schedule 6A of the PJM OATT, beyond which PJM will discontinue efforts to incent a replacement black start unit.

- F. After PJM and the TO have identified the most cost-effective replacement resource, PJM and the TO will coordinate with the GO for the GO's acceptance under the PJM tariff as a black start unit.

The replacement black start unit will be compensated for provision of the black start service in accordance with the existing process outlined in the PJM OATT. Schedule 6A of the PJM tariff sets forth a formula for payments to generators for black start service and the collection of such costs from transmission customers. The annual black start service revenue requirements of each generator are determined pursuant to this formula. The Schedule 6A formula includes allocation factors for fixed and variable generation costs, which are to be used unless another value is supported by the documentation of costs." The generator owner may choose compensation under the formulaic rate by submitting the formulaic black start costs to PJM as outlined in Section 4 of the **PJM Manual for Balancing Operations**, or by filing for recovery of actual costs, with accompanying documentation, to the FERC.



10.1.6 Replacement Process Step 5

If it is determined that a replacement resource will not be available prior to the proposed deactivation date of the black start unit or the proposed date of withdrawal of a black start unit from providing black start service, PJM, in accordance with the PJM Deactivation procedures (see Section 8 of this manual), will use the following process.

- A. PJM will identify whether there is a need to request that the generator continue to provide black start service beyond the planned deactivation date or withdrawal date of the black start unit, pending the upgrading of the transmission system in the form of replacement black start capability. Within 30 days of the GO's notification of the proposed deactivation or withdrawal of the black start unit from providing black start service, PJM will notify the GO whether there is a need for the black start unit proposed for deactivation or withdrawal to continue operating beyond its proposed deactivation date or withdrawal date.
- B. In the event that such notice requests that a black start unit proposed for withdrawal from providing black start service (but which is not deactivating) continue operating, the notice shall request that such unit voluntarily fulfill its two-year rolling commitment to provide black start service.
- C. In the event that the notice requests that a black start unit proposed for deactivation continue operating, the notice shall provide an estimate of the time period that the black start unit is needed to operate beyond its proposed deactivation date.
- D. Within 30 calendar days of such notice by PJM, the GO shall notify PJM whether the black start unit will continue operating beyond its proposed deactivation date or withdrawal date.
- E. A black start unit proposed for deactivation that operates beyond its deactivation date shall be compensated pursuant to the deactivation procedures set forth below and in Part V of the PJM Tariff.
- F. A black start unit proposing to withdraw from providing black start service (but which is not deactivating) that continues providing black start service for its entire rolling two-year commitment shall receive black start service revenues pursuant to Schedule 6A of the PJM Tariff but will not be eligible for compensation pursuant to Part V of the PJM Tariff.
- G. In the event that, through the market window process described above, a replacement black start resource is identified, PJM, as soon as practicable, shall notify the GO of such replacement, that its black start unit no longer will be needed for reliability, and the date the black start unit may withdraw from providing black start service or deactivate without affecting reliability..

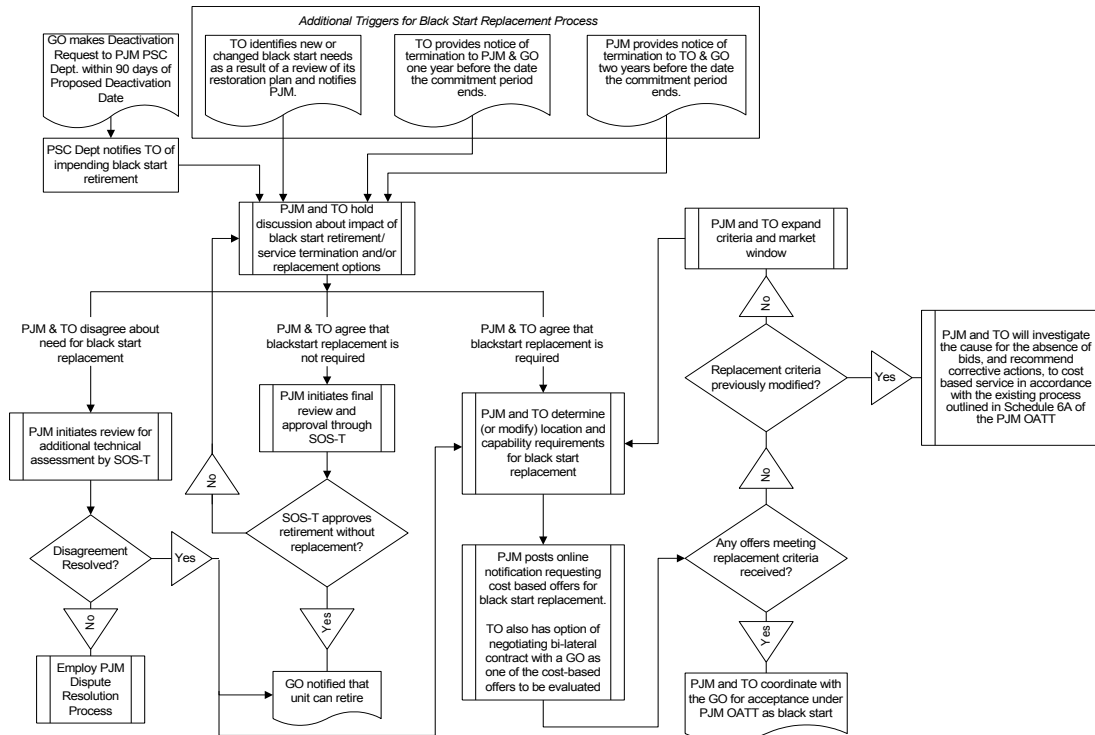

Exhibit 13: Black Start Replacement Process Flow Diagram

10.2 Cost-Based Components for Black Start Replacement

10.2.1 Capital Cost Components

The following capital cost components may be considered when documenting costs for constructing a new generator or retrofitting an existing generator for black start service capability. Submittal of actual costs with appropriate documentation to the FERC for approval is required under the existing process outlined in Schedule 6A of the PJM OATT.

- Cost of Capital strictly needed for Black Start Service Capability
- Capital Expense Categories for Black Start typically include:
 - Engineering
 - Construction
 - Diesel Generator
 - Electric Switchgear
 - Air Intake Pre-heater System
 - Control/Relay Modifications
 - Miscellaneous Expenses
 - Capital Structure
 - Total Project cost of Capital for Black Start Capability with Labor
 - Project Life
 - Tax Life
 - Depreciation Schedule (Term and Type)

10.2.2 Avoidable Cost Definition

The avoidable cost rate for providing Black Start Capability may be determined using the following formula:

Avoidable Cost Rate = Black Start Capital Cost * CRF

Where:

- Black Start Capital Cost is defined as the total cost of the capital components for constructing a new generator or retrofitting an existing generator for black start service capability as defined above.
- CRF is the annual capital recovery factor from the table below.



Age of Existing Unit (Years)	Remaining Life of Plant (Years)	Levelized CRF
1 to 5	20	0.125
6 to 10	15	0.146
11 to 15	10	0.198
16 to 20 Plus	5	0.363

Exhibit 14: Annual Capital Recovery Factors (Culled from Draft Tariff Attachment Y on Reliability Pricing Model)

Submission of actual avoidable costs with appropriate documentation to the FERC for approval is required under the existing process outlined in Schedule 6A of the PJM OATT.

10.2.3 Variable Cost Components

Variable costs for providing and maintaining black start capability should be documented following the revenue requirements defined in Schedule 6A of the PJM OATT, consisting of the following cost components:

- Plant Heat Rate
- Delivered Fuel Cost
- Short-term variable O&M (CDTF Based)
- Other Variable Costs strictly associated with Black Start Operations
- Long-term variable O&M and “~~at~~go” costs strictly associated with Black Start operations



Section 11: Generator Data Confidentiality Procedures

Welcome to the Generator Data Confidentiality Procedures section of the **PJM Manual for Generator Operational Requirements**. In this section you will find the following information:

- Description of the PJM generator data confidentiality procedures.

11.1 Generator Data Confidentiality Procedures

In order for PJM to perform reliability assessment and analyses, generators are required to provide real time and scheduled outage data to PJM. While PJM has the overall reliability responsibility for the PJM RTO, local Transmission Owners have a similar responsibility to monitor and assess the reliability of their transmission systems and distribution systems. In order for the Transmission Owners to perform their local reliability functions, Transmission Owners need certain data about the generators to formulate a realistic basis for the analysis. The following Generator Data Confidentiality Procedures pertain to only real time data (real time MW, MVAR, and unit status) and scheduled outage data (start date/time, return date/time, and derate). Scheduled outage data includes both planned and maintenance outage data.

Transmission Owners require both real time and generator data to perform their reliability and planning functions. These transmission owner functions include, but are not limited to:

1. Real time EMS applications: state estimator and security analysis
2. Transmission owner's real time role
3. Transmission outage scheduling process
4. Reliability study and training

PJM may be requested to provide a Transmission Owner with generator data. The Transmission Owner's responsibilities are different for generators located inside or outside of their transmission zone. To see the list of Transmission Owner's Rights and Responsibilities for generator data outside of its zone, reference the Generator Data Confidentiality Agreement in Attachment I of this manual.

11.1.1 Generator Data within a Transmission Owner's Zone

For generator data within a Transmission Owner's zone that PJM presently receives, a Generation Owner may authorize PJM to release this information to the Transmission Owner. The Transmission Owner who seeks data initiates this process by signing a letter and sending it to the Generation owner. A template letter describing how to start this process can be found in Attachment K of this manual.

11.1.2 Generator Data outside a Transmission Owner's Zone

The Generator Data Confidentiality Procedures that follow are applicable when a Transmission Owner seeks generation data from PJM. If a Transmission Owner needs access to generator data outside of its zone, the Transmission Owner uses the following process developed by the PJM Data Confidentiality Working Group to evaluate and authorize PJM to provide all available requested data. The Transmission Owner may



request PJM to provide Real-time (MW, MVAR and status) as well as future scheduled generator outage data.

11.1.3 Process to Authorize Release of Real-Time Generation Data

If the transmission owner can answer “Yes” to any of the following decision points about the real time generator data, explained in detail in Exhibit 16, then the Generator Owner will authorize the release of the data. If a Transmission Owner cannot answer “Yes” to any of the conditions, they can request an exception. All requests for exceptions must be documented in an attachment to the Generator – Data Release Matrix.

Process to Approve Real-Time Data Request
Decision Point 1: Is the Unit 2 Stations or less from the Transmission Owner’s Zone?
If the unit is two stations or less from the Transmission Owner’s Zone, then the request for data must be approved and the data confidentiality plan should be implemented.
Decision Point 2: Does Unit Outage affect network line flows by more than 2% line rating?
If a unit significantly changes line flows (changes by more than 2% line rating), it is important to get information on this unit’s availability out to the Transmission Owner. The line rating used should be the ratings at the peak ambient temperature set. If the unit outage affects network line flows by more than 2% line rating, then the request for data must be approved and the data confidentiality plan should be implemented.
Decision Point 3: Does Unit Outage affect Transmission Owner facility more than 5% dfax?
A dfax lists the units that harm or help a facility and the percentage of harm/relief that each additional megawatt per unit brings. If an outaged unit could significantly harm or help a facility by more than 5%, it behooves the transmission owner to know the status of this unit. If the unit outage does affect the Transmission Owner facility by more than 5% dfax, then the request for data on the unit in question must be approved and the data confidentiality plan will be implemented.
Decision Point 4: Does Unit Outage affect Transmission Owner model values by 5%?
If an outaged unit could change Transmission Owner model values by 5% or more, it is necessary for the Transmission Owner to know the status of the unit in question. If the unit outage does affect the Transmission Owner model values by 5%, the request for data must be approved and the data confidentiality plan will be implemented.
Decision Point 5: Is Plant interconnected at the 230 or above kV system?
Higher kV interconnection implies that the status of the unit may impact the Transmission Owner system more, making this particular unit status important information to know. If the plant is interconnected at the 230 or above kV system, the request for data must be approved and the data confidentiality plan will be implemented.
Decision Point 6: Is Plant 500 MW or greater?
A higher MW aggregate output of the plant implies that the status of the unit may impact a Transmission Owner’s system. If the plant is 500 MW or higher, the request for data must be approved and the data confidentiality plan will be implemented.

Exhibit 15: Process to Approve Real-Time Data Request – Decision Points with Definitions



11.1.4 Process to Authorize Release of Scheduled Generation Outage Data

If the transmission owner can answer “Yes” to any of the following decision points about the scheduled generation outage data, explained in detail in Exhibit 17, then the Generator Owner will authorize the release of the data. If a Transmission Owner cannot answer “Yes” to any of the conditions, they can request an exception. All requests for exceptions must be documented in an attachment to the Generator – Data Release Matrix.

Process to Approve Scheduled Outage Data Request
Decision Point 1: Is the Unit 2 Stations or less from the Transmission Owner’s Zone?
If the unit is two stations or less from the Transmission Owner’s Zone, then the request for data must be approved and the data confidentiality plan should be implemented.
Decision Point 2: Does Unit Outage affect Transmission Owner facility more than 5% dfax?
A dfax lists the units that harm or help a facility and the percentage of harm/relief that each additional megawatt per unit brings. If an outaged unit could significantly harm or help a facility by more than 5%, it behooves the transmission owner to know the status of this unit. If the unit outage does affect the Transmission Owner facility by more than 5% dfax, then the request for data on the unit in question must be approved and the data confidentiality plan will be implemented.

Exhibit 16: Process to Approve Scheduled Outage Data Request – Decision Points with Definitions

11.1.5 Executing a Data Confidentiality Agreement

After evaluating the applicability of the data request with the above decision points, the Transmission Owner initiates a Data Confidentiality Agreement with each Generator Owner. An officer of the Transmission Owner signs three copies of the Generator Data Confidentiality Agreement and submits them to the Manager of the PJM Power System Coordination Department. When initiating the Agreement, the PJM Generator Member Company name on record with PJM needs to be inserted into the beginning of the Agreement by the Transmission Owner. Any questions about the official Member Company name should be directed to the Manager of the PJM Power System Coordination Department. The Agreement can be found in Attachment I of this manual. (An electronic version of the Generator Data Confidentiality agreement is also available from the Manager of the PJM Power System Coordination Department.)

The agreement (all three copies) must also contain a Generator – Data Release Matrix. This Matrix lists all the generator units that a Transmission Owner requests data from a Generator Owner. Note that if the Transmission Owner wants to execute Agreements with several Generator Owners, an Agreement and accompanying Matrix must be filed for each Generator Owner. The Generator – Data Release Matrix (three copies) must be signed by the Transmission Owner’s Operating Committee Member before it is sent to PJM. If a Transmission Owner does not have an Operating Committee Member, the PJM Member Committee Representative will sign the Matrix. A sample Generator – Data Release Matrix can be found in Attachment J. (An electronic version of the Generator – Data Release Matrix is also available from the Manager of the PJM Power System Coordination Department.) The Transmission Owner should train the employees that will be working with this data (certificate signers) so they understand the confidential nature of the data.



An officer at PJM signs the Agreement and the PJM OC Representative signs the Generator – Data Release Matrix. The PJM Power System Coordination Department will send all three copies of the Agreement (with Matrix included) to the appropriate Generator Owner for a signature from an officer of the company. At this time, the Operating Committee Representative (or PJM Member Representative) of the Generator Owner signs the copies of the Generator – Data Release Matrix. The Generator Owner then returns two copies of the Agreement (with Matrix included) back to the PJM Power System Coordination Department. PJM retains a copy of the executed agreement and matrix and sends a copy to the Transmission Owner for their records. After the Agreement has been executed, the Transmission Owner will be authorized to have the generator data.

If a Data Confidentiality Agreement has been executed between a Transmission Owner and Generator Owner, and the Transmission Owner wishes additional generator data, another Matrix (3 copies) should be filed requesting the new units. This Matrix should be initiated and authorized by the Transmission Owner's Operating Committee Representative (or PJM Member Committee Representative) and sent to the Manager of the PJM Power System Coordination Department. PJM's Operating Committee Representative will sign the Matrix and forward it to the Generator Owner's Operating Committee Representative. The Generator Owner's Operating Committee Representative will keep one copy of the newly executed Matrix and return the other two to the PJM Power System Coordination Department. PJM will retain one for its records and send the other back to the Transmission Owner. After the Generator Owner's Operating Committee Representative (or PJM Member Committee Representative) returns the signed Matrix to PJM, the Transmission Owner is authorized to receive the additional generator data.

11.1.6 PJM Evaluation of Data Request

Annually, PJM will send a list to the Generator Owners stating their data that is being sent to each Transmission Owner. The Generator Owner may challenge this data release by using the dispute resolution process.

The Transmission Owner must provide the decision point under which they believe their request qualifies, and if requested, provide supporting information to PJM and the Generator Owner. If requested by a Generator Owner, PJM will evaluate the technical merits of the request using the PJM EMS model.

11.1.7 Dispute Resolution

The process for appeal is to follow the PJM Dispute Resolution Process. Further information about this process may be found in Section 5 of the ***PJM Manual for Administrative Services for the PJM Interconnection Agreement***.



Attachment A: New Generator Checklist

Operations	Status	
	Date	
	Needed	Complete
Dispatch	<input type="checkbox"/>	<input type="checkbox"/>
Control	<input type="checkbox"/>	<input type="checkbox"/>
Plant Operation	<input type="checkbox"/>	<input type="checkbox"/>
Emergency Procedures	<input type="checkbox"/>	<input type="checkbox"/>
PJM Communications	<input type="checkbox"/>	<input type="checkbox"/>
Restoration	<input type="checkbox"/>	<input type="checkbox"/>
Loading Reserves	<input type="checkbox"/>	<input type="checkbox"/>
Regulation	<input type="checkbox"/>	<input type="checkbox"/>

Data	Status	
	Date	
	Needed	Complete
Telemetry ¹	<input type="checkbox"/>	<input type="checkbox"/>
Unit Commitment ²	<input type="checkbox"/>	<input type="checkbox"/>
Outages	<input type="checkbox"/>	<input type="checkbox"/>
Meter Error Correction	<input type="checkbox"/>	<input type="checkbox"/>

Market	Status	
	Date	
	Needed	Complete
Energy Transactions	<input type="checkbox"/>	<input type="checkbox"/>
- Within PJM	<input type="checkbox"/>	<input type="checkbox"/>
- Outside of PJM	<input type="checkbox"/>	<input type="checkbox"/>
Capacity Transactions	<input type="checkbox"/>	<input type="checkbox"/>
FTRs	<input type="checkbox"/>	<input type="checkbox"/>
Synchronized Reserve	<input type="checkbox"/>	<input type="checkbox"/>
Regulation	<input type="checkbox"/>	<input type="checkbox"/>
Reactive*	<input type="checkbox"/>	<input type="checkbox"/>
Black Start	<input type="checkbox"/>	<input type="checkbox"/>

Exhibit 17: New Generation Checklist Page 1 of 3

¹ Real-time and integrated meter data.

² Daily schedule and bids, cost curves, start and no-load costs, etc.

* Anticipated Future.



Administrative	Status	
	Date	
	Needed	Complete
Membership Application ³	<input type="checkbox"/>	<input type="checkbox"/>
Interconnection Agreement	<input checked="" type="checkbox"/>	<input type="checkbox"/>
Firm Transmission Service ⁴	<input type="checkbox"/>	<input type="checkbox"/>
Non-Firm Transmission Service ⁵	<input type="checkbox"/>	<input type="checkbox"/>
Billing Contact Information Form	<input checked="" type="checkbox"/>	<input type="checkbox"/>
Committee Registration Forms	<input checked="" type="checkbox"/>	<input type="checkbox"/>
Capacity Transaction Authorization ⁶	<input checked="" type="checkbox"/>	<input type="checkbox"/>
eCapacity Registration ⁷	<input checked="" type="checkbox"/>	<input type="checkbox"/>
eSchedule Registration	<input checked="" type="checkbox"/>	<input type="checkbox"/>
eMKT Registration	<input checked="" type="checkbox"/>	<input type="checkbox"/>
eMTR Registration	<input checked="" type="checkbox"/>	<input type="checkbox"/>
eFTR Registration	<input checked="" type="checkbox"/>	<input type="checkbox"/>
OASIS Registration	<input checked="" type="checkbox"/>	<input type="checkbox"/>
eGADS Registration	<input checked="" type="checkbox"/>	<input type="checkbox"/>
eData Registration ⁸	<input checked="" type="checkbox"/>	<input type="checkbox"/>
eDART Registration ⁹	<input checked="" type="checkbox"/>	<input type="checkbox"/>

Training	Status	
	Date	
	Needed	Complete
PJM Overview	<input checked="" type="checkbox"/>	<input type="checkbox"/>
eCapacity	<input checked="" type="checkbox"/>	<input type="checkbox"/>
eSchedules	<input checked="" type="checkbox"/>	<input type="checkbox"/>
eFTR, eMTR, eMKT	<input checked="" type="checkbox"/>	<input type="checkbox"/>
OASIS	<input checked="" type="checkbox"/>	<input type="checkbox"/>
eGADS, eDART, eFuel, Generator Outage Reporting	<input checked="" type="checkbox"/>	<input type="checkbox"/>
Unit Commitment	<input checked="" type="checkbox"/>	<input type="checkbox"/>
LMP	<input checked="" type="checkbox"/>	<input type="checkbox"/>
Operations	<input checked="" type="checkbox"/>	<input type="checkbox"/>
Dispatcher	<input checked="" type="checkbox"/>	<input type="checkbox"/>
Communications	<input checked="" type="checkbox"/>	<input type="checkbox"/>
Emergency Procedures	<input checked="" type="checkbox"/>	<input type="checkbox"/>
Market Settlements	<input checked="" type="checkbox"/>	<input type="checkbox"/>

Exhibit 18: New Generation Checklist Page 2 of 3

³ Membership Application – <http://www.pjm.com/>

⁴ Firm Transmission Service Application – <http://www.pjm.com/services/downloads/trans.DOC>

⁵ Non-Firm Transmission Service Application – <http://www.pjm.com/services/downloads/trans.DOC>

⁶ Capacity Transaction Authorization Form – <http://www.pjm.com/custchoice/cccheck/inscap.pdf>

⁷ eCapacity/eSchedules Registration – http://www.pjm.com/forms/eschedules_user_registration.html

⁸ eData Registration – <http://edata.pjm.com/>

⁹ eDART Registration – http://www.pjm.com/edart/edart_index.html



Systems/Communications	Short Term	
	Date	
	Needed	Complete
Communications	<input type="checkbox"/>	<input type="checkbox"/>
Telemetry		
ICCP EMS Links	<input type="checkbox"/>	<input type="checkbox"/>
Metering Links	<input type="checkbox"/>	<input type="checkbox"/>
PJMnet		
Frame Relay	<input type="checkbox"/>	<input type="checkbox"/>
ISDN Backup	<input type="checkbox"/>	<input type="checkbox"/>
POTS line for router	<input type="checkbox"/>	<input type="checkbox"/>
Routers	<input type="checkbox"/>	<input type="checkbox"/>
IGN Network		
Frame	<input type="checkbox"/>	<input type="checkbox"/>
Routers	<input type="checkbox"/>	<input type="checkbox"/>
Other devices (TBD)	<input type="checkbox"/>	<input type="checkbox"/>
Voice		
Generator ALL CALL	<input type="checkbox"/>	<input type="checkbox"/>
POTS	<input type="checkbox"/>	<input type="checkbox"/>
Systems/Applications		
EMS		
System Changes	<input type="checkbox"/>	<input type="checkbox"/>
Modeling	<input type="checkbox"/>	<input type="checkbox"/>
PJM Testing	<input type="checkbox"/>	<input type="checkbox"/>
Integration Testing	<input type="checkbox"/>	<input type="checkbox"/>
Unit Commitment (eMKT)		
System Changes	<input type="checkbox"/>	<input type="checkbox"/>
Permission to view existing data	<input type="checkbox"/>	<input type="checkbox"/>
Testing	<input type="checkbox"/>	<input type="checkbox"/>
Regulation Logger		
System Changes	<input type="checkbox"/>	<input type="checkbox"/>
Testing	<input type="checkbox"/>	<input type="checkbox"/>
Two-Settlement (eMKT)		
System Changes	<input type="checkbox"/>	<input type="checkbox"/>
Testing	<input type="checkbox"/>	<input type="checkbox"/>

Exhibit 19: New Generation Checklist Page 3 of 3



Attachment B: New PJMnet Customer Implementation Voice/Data Communications Template



*New PJMnet Customer Implementation
Voice/Data Communications*

Objective

The completion of this document will provide PJM with the information necessary to configure and install the required voice and data communications necessary for you, our new customer, to communicate with PJM. PJM will assume total responsibility for the coordination efforts required to acquire and implement the appropriate telecommunications circuits.

Customer Information

PJM Member Name: _____

Customer Business Name: _____

Customer Business Address: _____

Customer Business Contact: _____

 Telephone Number: _____

 Fax Number: _____

 email Address: _____

Customer Technical Representative: _____

Customer Technical Representative email: _____

Customer Technical Representative Fax Number: _____

Total Number of MW at Site/for which site is responsible: _____

 Site Access Hours: _____

 Site Access Requirements: _____



Site Circuit Information

Desired hardware install by date: _____

Desired circuit fully operational date: _____

Area code and exchange telephone number where circuit is to be terminated:

Location Name: _____

Street: _____

City: _____ State: _____ Zip Code: _____

Site Point of Contact: _____

Site Point of Contact Telephone Number _____

Site Point of Contact email _____

Site Point of Contact Fax Number _____

Circuit Termination: _____

Floor/Room Number/Name: _____

Telephone Number (within 5 feet of router) _____

For the purposes of remote router support POTS lines need to be installed for each router.

Number Assigned: _____

Number Assigned: _____

Site Circuit Termination Design:	YES	NO
Diverse Telecommunications Entrance Facilities into Site	<input type="checkbox"/>	<input type="checkbox"/>
Telecommunication carrier demarcation location different from install location	<input type="checkbox"/>	<input type="checkbox"/>
Termination capacity currently exists	<input type="checkbox"/>	<input type="checkbox"/>

Demarcation Extension to be performed by: None Telco Site Staff



Circuit Configuration (provided by PJM)

- | | | |
|--|---|-----|
| Physical Address DS1 | Port Speed | CIR |
| <input type="checkbox"/> PVC to PJM Primary Control Center | <input type="checkbox"/> PVC to PJM Emergency Backup Control Center | |

Circuit Notes:

PJM Supplied Hardware Information

- Very Large (A) Large (B) Medium (C) Small (D)
- Communication Protocol: ICCP DNP EMS SCADA

PJMnet Router Type:

ARCOM devices required (DNP implementations only) Yes No

Hardware Notes:

Note for electrical facilities that have a major impact on PJM operations: PJM requires the computer hardware and software at each control center should achieve a long-term 99.95% availability level for those critical functions directly affecting the successful operation of PJM. Redundant hardware configurations with either automatic or rapid manual failover schemes are generally necessary to achieve 99.95% availability. In addition, reliable AC power source(s) and communications are also necessary. Members should keep this requirement in mind when designing these systems.

Customer Site Environment Information

Site Power Configuration (diversity/redundancy):	YES	NO
Separate Equipment Breakers	<input type="checkbox"/>	<input type="checkbox"/>
Separate Electrical Panels for Equipment	<input type="checkbox"/>	<input type="checkbox"/>
Uninterruptible Power Supply	<input type="checkbox"/>	<input type="checkbox"/>
120v/60 Hz AC Power Available	<input type="checkbox"/>	<input type="checkbox"/>

If no AC power is available, please describe available power:



Date Site Survey Completed: _____

Network Information

Network Address: _____ Subnet Mask: _____

IP Address for PJM Router: _____

Will this network be protected by a firewall? Yes No

Will the firewall be providing Network Address Translation (NAT)? Yes No

Will the firewall be in service during router installation? Yes No

Please provide a contact for the firewall administrator

Name: _____ Phone: _____

Can IP 10.134. be used by PJM? Yes No

If yes, supply a 10.34.xx address that will be used as a loop back address. -10.34.

Please list what devices (RTU, Meter< FEP, etc.), device type (DNP, ICCP) IP Address will be monitored:

Device Name/Type	Communications Protocol	IP Address
------------------	-------------------------	------------



Attachment C: New PJM Customer Voice/All Call Communications Request Form

Objective

This document will provide PJM with the information necessary to implement voice (two-way) and All Call (one-way) communications, which are essential for operation of the PJM grid.

Customer Information

PJM Member Name:

Customer ~~Contact~~ Business Representative:
_____ -Name:

Address:

Telephone:

E-mail Address:

Formatted: Indent: Left: 0", First line: 0"

Formatted: Indent: Left: 0"

Formatted: Indent: Left: 0"

~~Customer Technical Representative~~:
_____ Name: _____

_____ Address: _____

_____ Telephone: _____

_____ Fax: _____

_____ E-mail Address: _____

Customer Type: (check the one that applies)

Generation Station: , Transmission Dispatch Center: , Demand Side Response
Generation Dispatch Center: , Market Operations Center: , Electric Distribution Center

PJM Region _____ PJM Control Zone _____

PJM Transmission Zone(s) of Operation _____



Site Information:

Total Number of MW at Site/for which site is responsible:

Site Access Hours: _____

Site Access Requirements: _____

Desired date of operation: (mm/dd/yy)

Desired date for testing: (mm/dd/yy) _____

Location where the phone call is received ~~(some entries may be duplicates)~~:

Address (Street address, City, State, Zipcode):

Location name: _____

Street Address: _____

Building name: _____

Suite name: _____

Floor level: _____

Room Number: _____

Title of person: _____

Contact Person at site location

Name: _____

Telephone Number: _____

E-mail Address: _____

Two Way Voice Communication Information:

Primary **dedicated** phone number for PJM Dispatch Operations to call:

Secondary **dedicated** phone number for PJM Dispatch Operations to call:

Formatted: Font: Bold, Italic

Formatted: Font: (Default) Arial, 15 pt, Bold, Italic

Formatted: Font: Bold

Formatted: Font: Bold



PJM All Call Information:

(PJM requires a Primary phone number dedicated solely to PJM for operation and emergency communications. All Call may not terminate in voice mail, Automatic Call Distribution (ACD) or answering systems)

Primary number:

(Must be a dedicated line dedicated solely to PJM for operation and emergency communications. The number must be in a facility and position that is staffed 24 hours a day and 7 days a week)

(Secondary and/or Tertiary lines may be shared lines or cellular numbers, indicate if cellular)

Secondary Number: Cellular: YES NO

(May be shared lines or cellular numbers, indicate if cellular)

Tertiary Number:

(May be shared lines, indicate if cellular)

All Call Location:

(Ex: plant control room, office, generation or transmission dispatch)

Primary responsibility of person responding to All Call (enter job title)

Will All Call terminate in a speaker system? YES NO

Would you like technical assistance in adapting the All Call to PBX/turret/speaker system?

YES NO

Approvals:

(This is for PJM internal processes – Please provide your PJM Contact's name)

Name of Author of form: _____

Address of Author of form: _____

Telephone Number of Author of form: _____

Name and title of person authorized to change phone information: _____

(Only if different from author of form)

Client Manager _____ Dispatch Check _____
(PJM use only) (PJM use only)



Contact Will Lebus (610-666-4782) or Jay Stauffer (610-666-2272) for technical assistance or questions in completing this form.



Attachment D: PJM Generating Unit Reactive Capability Curve Specification and Reporting Procedures

The purpose of this attachment is to provide further explanation of the PJM Generating Unit Reactive Capability Curve Specification and Reporting Procedures that are discussed in this manual Section 7: *Generator Operations*.

Specifications

Listed below are the specifications for the Continuous Generating Unit Reactive Capability Curve (required by PJM).

1. The following data for each point on the curve must be specified:
 - A. In general, the “Unit Net MW Output” provided to the system, as measured at the low-side of the unit step-up transformer, excluding any station service load fed of the unit terminal bus, consistent with the PJM EMS model.
 - B. The leading or lagging “Unit Minimum Net MVAR Limit” at the specified “Unit Net MW Output”, consistent with the PJM EMS model.
 - C. The leading or lagging “Unit Maximum Net MVAR Limit” at the specified “Unit Net MW Output”, consistent with the PJM EMS model.
2. The “Unit Minimum and Maximum Net MVAR Limits” must indicate the realistic, usable capability that is sustainable during continuous long-term unit operation. This sustainable continuous capability is based on actual operating experience (or testing) and takes into consideration any normal unit or plant restrictions at 95 degrees Fahrenheit ambient or above. Therefore, the reactive capability derived results in the proven sustainable reactive capability, rather than merely reflecting the design limits of the unit.
3. A sufficient number of curve points must be provided to accurately model the full operating range and capability of the unit as described above.

Data Requirements

1. A minimum of two curve points must be provided.
2. A maximum of eight curve points may be provided.
3. The “Unit Maximum Net MVAR Limit” must be greater than (or equal to) the “Unit Minimum Net MVAR Limit” for each curve point.
4. The “Unit Minimum Net MVAR Limit” may be equal for any number of adjacent curve points.
5. The “Unit Maximum Net MVAR Limit” may be equal for any number of adjacent curve points.
6. The “Unit Net MW Output” must be increasing from the first to the last point.
7. Company can either test or apply the best engineering judgment to construct D-curve at min load points.



Data Format

Data should be provided to PJM in the format shown in the exhibit below via eDART.

(Note that if a unit's current default curve in eDART has less than eight points, a revised curve with more points can be entered in the eDART "Description" field):

	MW	Minimum MVAR	Maximum MVAR
Point 1			
Point 2			
Point 3			
Point 4			
Point 5			
Point 6			
Point 7			
Point 8			

Exhibit 20: PJM Unit Reactive Capability Curve Data Format

PJM Unit Reactive Capability Curve Reporting Process for Permanent Changes

1. Each Generation Owner/Operator must continually provide accurate permanent capability curve changes to PJM via eDART as soon as the information is available. The "New Default" field should be checked in eDART.
2. Once the accuracy of the submitted reactive capability curve is verified, PJM will permanently update the PJM Unit Reactive Capability Curves in use by PJM Operating/Planning Studies and PJM EMS Network Applications programs.

Real-Time PJM Unit Reactive Capability Reporting Process for Temporary Changes

1. Whenever a PJM unit's reactive capability is limited or reduced (or is planned to be limited or reduced) for any reason, the generator's owner/operator must immediately enter a temporary ticket via eDART. For real-time changes, the generator's owner/operator should also notify the PJM Power Dispatcher (PD) and respective LCC by phone.
2. Whenever a PJM unit's Automatic Voltage Regulation (AVR) status is off (or is planned to be off), the generator's owner/operator must immediately enter a ticket via eDART. For real-time changes, the generator's owner/operator should also notify the PJM Power Dispatcher (PD) and the respective LCC by phone.
3. The PJM PD will receive the ticket and either temporarily update the unit's reactive capability curve in use by the PJM EMS Network Applications, or will temporarily set the unit's AVR status in use by the PJM EMS Network Applications to "OFF" for the specified time period.



4. The generator's owner/operator must immediately modify the eDART ticket and notify the PJM PD and respective LCC by phone whenever the unit's normal reactive capability or AVR is restored (or is anticipated to be restored).
5. The PJM PD will either restore the unit's normal reactive capability curve in use by the PJM EMS Network Applications, or will set the unit's AVR status in use by the PJM EMS Network Applications to $-\Theta N$ ". The PJM PD will then close the unit reactive ticket.

PJM Reactive Reserve Check (RRC)

1. Upon the request of PJM, all Transmission Owner LCC's will provide a Reactive Reserve Check (RRC) report to PJM. PJM dispatch generally requests a RRC during capacity deficient conditions or when a Heavy Load Voltage Schedule Warning is implemented, and periodically on Sundays for testing purposes.
2. This report, filled out in eDart RRC form, will include the following information within the Transmission Owner's zone:
 - A. Unit MVAR Reserve (The sum of the differences between the present operating points, leading or lagging, and the lagging MVAR capability of all synchronized units.)
 - B. Lagging MVAR Reserve (The sum of the lagging MVAR capability of all online condensers and Static VAR Compensators (SVCs).)
 - C. Transmission Capacitor/Reactor MVAR Reserve (The sum of the nameplate MVAR values of capacitors that are capable of being energized or reactors that can be removed from service.)

Note: The first two items require open dialogue between the Transmission Owner and the Generation Owners within the Transmission Owner's footprint.

3. PJM will make the report available to LCC's.



PJM Reactive Reserve Check (RRC)			
Transmission Owner	Unit MVAR Reserve	Lagging MVAR Reserve	Transmission Capacitor/ Reactor Reserve
PJM TOTAL			

Exhibit 21: PJM Reactive Reserve Check (RRC)

PJM Actions:

1. PJM dispatcher requests LCCs to provide Reactive Reserve Check Data for the entire PJM CA or on a Control Zone basis, as necessary. An eDart RRC report ID will be via all-call.
2. PJM dispatcher takes a snapshot of reactive reserves from the PJM EMS system for comparison purposes.
3. PJM dispatcher works with LCC to resolve/rationalize reported differences in reactive reserves. PJM and TO maintain reserve data on a per Unit basis within dispatch control room in order to resolve data discrepancies.
4. PJM dispatcher / LCC / MOC modify reactive curves as appropriate to ensure accurate Security Analysis results.

PJM Member Actions:

1. Transmission / Generation dispatchers review reactive capability curves.
2. Generation Dispatchers update eDART Reactive Capability Curve to reflect changes and indicate if temporary or new default.
3. Transmission Dispatcher review eDART for any changes to reactive capability curves and update LCC EMS.
4. Transmission Dispatchers poll MOC's or specific plant regarding changes to reactive capability curves.
5. Transmission Dispatcher maintains reserve data on a per unit basis, within the control room, in order to resolve data discrepancy issues between MOC, plant, and/or PJM.
6. PJM MOCs remain on heightened awareness and notify TO/PJM regarding unit performance issues and update eDART as appropriate.
7. Transmission Dispatchers enter data in eDart via the RRC Form.



Attachment E: PJM Generator Reactive Capability Testing

Objective

The objective of reactive capability testing for generators is to improve the transmission system reliability by accurately determining generator reactive capability on a regular basis. Also, this testing could identify any conditions which are limiting the reactive capability of generating units in PJM. PJM encourages testing to be coordinated between PJM, the Generator Owner, and the local Transmission Owner to ensure that the impact on system operations is minimized. Testing is intended to demonstrate reactive capability for those conditions where reactive reserves would be required.

PJM will evaluate the Generator Reactive Capability Testing requirements contained within this document and may expand testing to various MW output levels if experience indicates it is beneficial to do so.

General Requirements

1. Units with a nominal capacity greater than 70 MW and black start units will be required to perform a reactive capability test.
2. All other units with capacity less than 70 MW and non-black start units will verify the reactive capability reported in the PJM e-DART system on a periodic basis consistent with PJM Manual 14D.
3. Generation Owners are required to test 20% of the number of their eligible assets annually, totaling 100% of their eligible assets over a 5-year period. More frequent testing may be done if the Generator Owner so chooses.
4. The PJM generator reactive capability testing period will begin on May 1 and continue through September 30. This testing cycle will repeat on an annual basis, ensuring that all designated units are tested at least once in a five year cycle.
5. Generator reactive capability testing will take place Monday thru Friday, between 0900 and 1100 hours, Eastern Time.
6. The Generator Owner will determine the best time to conduct these tests. This test may be conducted in conjunction with other testing (including the Net Demonstrated Capability testing), provided all other requirements of this test are met. All equipment will be tested with all auxiliary equipment needed for normal operation in service.
7. As an alternative, data collected during routine operation of the unit is acceptable, provided all test requirements are met.
8. The tests required are functional and do not require special instrumentation. They are designed to demonstrate that the ratings can be obtained for the time periods required under normal operating conditions for the equipment being tested.
9. Projected system conditions must permit the unit to operate at full capacity without adversely impacting system operations.
10. PJM will consider other test periods on a case by case basis, so long as proposed testing periods do not adversely impact system operations.



Testing Requirements for both Units Larger than 70 MW and Black Start Units

1. The over-excited (lagging) and under-excited (leading) reactive capability outputs (MVAR) is required to be tested at or near demonstrated capability (i.e. a single MW point test).
2. A steady active and reactive power output will be maintained during the test.
3. Exception Criteria: Lagging/Leading tests are required depending on unit type. All exceptions must be documented and reviewed by PJM and Transmission Owners. Test requirements are as follows:

Unit Type	Required Testing	Exception Criteria
Nuclear	Lagging Test	Documented Exception to Lagging based on impact to System Reliability
Black Start Near-term Steam	Lagging Test Leading Test	Not Applicable
All Other	Lagging Test 0 MVAR Test	Documented Exception to Lagging test based on impact to System Reliability
<p>Note: Near-term Steam units are defined as steam units with a hot start plus (+) notification time of less than 8 hours. The list of units is maintained by PJM and located in Transmission Owners Restoration Plan.</p>		

4. The reactive capability curve and minimum excitation limiter settings for each machine will be used to determine the expected reactive capability. If a machine has been tested previously, the expected reactive capability for a new test should reflect the reactive capability that was demonstrated.
5. Units are to be tested while maintaining the voltage within normal operating limits on the system bus (pre- and post-contingency voltage limits). This requirement may require a departure from scheduled voltage during the test, provided no adverse effect on the validity of test results can be demonstrated. The Generator Owner will need to coordinate between its designated LCC, PJM, and other units in order to allow the unit being tested to demonstrate its maximum reactive capability while maintaining system voltages within acceptable limits.
6. All reasonable measures shall be taken to ensure the results from the reactive capability test are based upon actual operating conditions. If it is not possible to maintain the system voltage within operating limits, for non-black start unit leading capability tests, then it is acceptable to calculate the non-black start unit leading



reactive capability quantities. Calculated test results will not be acceptable on an on-going basis. Black start units and Near-term Steam units are required to test both leading and lagging reactive capability.

7. For hydrogen-cooled generators, the hydrogen pressure should be raised to the normal operation pressure. If the hydrogen pressure cannot be raised, then the reason for this condition should be documented and the appropriate reactive capability curve should be used.
8. The over-excited reactive capability test should be conducted for a minimum of one hour. Data for the under-excited reactive capability test may be recorded as soon as a limit is encountered.
9. When the maximum sustained over-excited and under-excited reactive output during the test is achieved, the MW and MVAR outputs at the generator terminals (low side gross), auxiliaries, the generator step-up transformer (GSU) primary (low side net, after auxiliaries), and the GSU secondary (high side net) should be recorded.

If metering is unavailable, it may be necessary to calculate some of these quantities. A note should be provided in the "Remarks" section of "Lagging and Leading/Zero Form R" for points which are calculated.

PJM will evaluate the reported values as compared to the average values consistent with requirements. The average values will serve as the basis for modifying the default reactive curves within eDart.

10. During the test, the scheduled and actual voltages at the system bus and the generator terminals should also be recorded. In addition, the nameplate GSU impedance, MVA rating, primary and secondary voltage ratings and available tap settings, and the existing GSU tap setting should be provided.
11. The reasons for any limit to unit reactive capability during the test should also be specified (for example, reactive capability curve limit, minimum excitation limiter settings, field current limitation, generator voltage, auxiliary bus voltage, system voltage limits, generator vibration, generator temperatures, hydrogen pressure restriction, shorted rotor turns, etc.) in the remarks section.

Notification and Reporting Requirements

If non-cost operations (the adjustment of generator MVAR output or the movement of PAR or LTC transformer taps) or off-cost operations are required to accommodate the test, PJM will communicate these requests directly to the appropriate LCCs and MOCs.

MOC Actions:

- Proposed testing dates/times should be communicated via eDart to the PJM Dispatch, PJM Reliability Engineer and LCC no later than noon 3 business days prior to the test, ensuring testing impacts are incorporated into day-ahead studies. PJM and LCCs will consider shorter notification times and try to accommodate reactive testing while ensuring that operating limits are not violated.
- The test notification will be submitted using a "MVAR Test" Ticket in which the test duration should be provided, as well as any additional relevant information for the test within the description field.



- Prior to the test scheduling, the MOC (Generation Owner) shall confirm with PJM Reliability Engineer that MW and MVAR data is being provided to PJM via ICCP. If issues are identified, they are required to be resolved before proceeding with the test scheduling of the unit
- Any scheduled or unscheduled maintenance work on the unit scheduled for testing must be complete and all eDART tickets cleared prior to contacting PJM for the purpose of initiating the study process.
- The MOC will contact PJM Reliability Engineer at least three hours prior to the start of the scheduled testing in order to initiate the real-time study process.
- Real-time testing should be coordinated with LCC and PJM Transmission dispatchers. At least 30 minutes notice should be provided to allow PJM and LCC operators to adjust the system to ensure testing does not result in voltage limit violations.
- The MOC will coordinate any required transmission mitigation steps to resolve internal plant limitations with PJM Reliability Engineer.
- If testing must be canceled or rescheduled, the MOC will inform PJM Reliability Engineer as soon as possible.
- The MOC will coordinate the implementation of their portion of the exit strategy with PJM, if required.
- Generator Owner shall submit complete PJM Leading and/or Lagging Test Form R to reactivetesting@pjm.com within 30 calendar days after completion of the testing.
- The MOC will coordinate all actions with PJM dispatch.

LCC Actions:

- The appropriate LCCs will conduct studies in accordance with established company procedure in order to determine the effect of scheduled testing on their systems.
- LCC should contact PJM Reliability Engineer with any possible concerns regarding the scheduled testing.
- LCC support staff will ensure that the LCC operators are aware of scheduled reactive capability tests and communicate the pre-studied mitigating action plan.
- Prior to studying the test, the LCC will verify, with the PJM Reliability Engineer and the generating station, the expected MW and MVAR output levels of the unit during testing, and ensure that the AVR is in service.
- The LCC will contact the PJM Reliability Engineer no later than two hours and 15 minutes prior to the scheduled test start time in order to discuss the results of their studies and the mitigating steps required, if any.
- The LCC will discuss, coordinate, and implement any actions necessary as required by mitigation strategies with PJM prior to the start of testing.
- The LCC will communicate MVAR output step changes to the testing unit in coordination with PJM. In general, MVAR step changes should be no greater than 100 MVAR increments.



- If testing must be canceled or rescheduled, the LCC will inform PJM Reliability Engineer as soon as possible.
- The LCC will coordinate the implementation of their portion of the exit strategy with PJM, if required.
- The LCC will coordinate all actions through PJM Reliability Engineer.

PJM Actions:

- All testing requests will be reviewed by PJM Reliability Engineers and Power Directors to ensure that there is no conflict between the testing and any planned transmission outage. PJM will give the MOC a suggestion for a more appropriate date and time to conduct the test, if necessary.
- PJM Reliability Engineer shall verify the accuracy of the telemetry data with the generation owners prior to commencing the test. If issues are identified, they are required to be resolved before proceeding with the test scheduling of the unit
- PJM Reliability Engineer and Power Director will review and approve the test in accordance with the established PJM procedure.
- PJM Reliability Engineer will ensure that PJM dispatch is aware of scheduled reactive capability tests and communicate the pre-studied mitigating action plan via the PJM Transmission Log.
- Once the PJM Reliability Engineer is contacted by the MOC, they will contact the LCCs of all regions concerned in order to initiate the transmission operator's study process. They will verify the expected unit output levels with the LCC and ensure that the AVR is in service.
- PJM Reliability Engineer will re-evaluate the pre-studied mitigating action plan prior to test commencement and communicate any necessary adjustments to the impacted parties.
- PJM Reliability Engineer and/or Dispatch will discuss possible mitigation strategies with the appropriate LCCs.
- PJM Reliability Engineer will contact the MOC no later than two hours prior to scheduled testing to inform them whether mitigation steps will be required.
- PJM Reliability Engineer will coordinate with the appropriate MOCs and LCCs in order to implement the selected mitigation strategy.
- PJM Reliability Engineer will coordinate with the LCC in making MVAR output step changes with the testing unit.
- If the testing must be cancelled or rescheduled, PJM Reliability Engineer will contact the MOC and LCCs as soon as possible.
- PJM Reliability Engineer will coordinate the implementation of the exit strategy with the MOC and LCCs, if required.
- PJM Reliability Engineer will coordinate all actions and communications between the MOC and LCCs.



Test Cancellation

PJM dispatch and/or the impacted parties may cancel the generator reactive capability testing for the following reasons:

- Internal planning issues.
- Emergency procedures.
- Inability to control actual or post-contingency voltage issues created by scheduled testing.
- Any operating issues created on LCC equipment not monitored by PJM.

Cancellation of the generator reactive capability test will be communicated to all impacted parties.

PJM will document all cancellations and terminations including the party responsible and the reason for the cancellation or termination.

Voltage Schedules

Adjustments may need to be made to local voltage schedules in order to accommodate the scheduled testing. These adjustments will be considered and studied on a case by case basis.

Note: Deviate from voltage schedule to demonstrate reactive capability while monitoring impacts to limits using SA packages.

PJM will discuss the changes with the appropriate LCC and if the recommendation does not cause a violation of a defined limitation, the LCC should implement the PJM request.

PJM will retain its control of the reactive facilities, such as transmission capacitors, LTCs, and generator MVAR output.

If internal plant or LCC limits restrict the request, PJM dispatch will study the limitations and recommend changes to plant facilities if appropriate.

If the recommended changes cannot be implemented due to equipment or facility limitations, other options will be considered, including test cancellation or rescheduling.

Exit Strategy

Risk

PJM will not allow scheduled generator reactive capability testing to place the system in an unacceptable state. However, there is always the possibility of equipment failure resulting in unplanned situational constraints that would require immediate remedial action.

Requirements

The following are steps that will be considered and agreed upon prior to allowing the scheduled generator reactive capability testing;

Each scheduled test will be studied and approved on a case by case basis.



All required mitigation steps will be agreed to and coordinated with all concerned parties, to include PJM Reliability Engineer, the responsible MOC, and the appropriate LCCs, prior to the scheduled testing.

Parameters

PJM will NOT allow operation over any applicable post-contingency STE or LTE ratings.

PJM will NOT allow operation over any applicable pre-contingency normal rating.

In the event of a facility rating discrepancy between PJM and the LCC that cannot be resolved, PJM will default to the most conservative limit.

In the event that the testing results in an unexpected thermal or voltage violation, standard mitigation steps will be taken to return the facilities in violation back to normal limits within fifteen minutes.

The mitigation steps taken will not cause limit violations on any other company's equipment or facilities.

Post-Test Evaluation

PJM will provide feedback on a periodic basis to generation owners on the status of their reactive capability test results. PJM will also provide the results of generation reactive capability tests to the appropriate LCC operator.

PJM will analyze the reactive capability test results in the same calendar year in which the reactive capability test was performed for the unit.

PJM Staff will conduct periodic audits of generator reactive capability test results and will provide summary report information to the PJM System Operations Subcommittee and the PJM Operations Committee on a periodic basis.

Test Evaluation

PJM will evaluate each unit's reactive capability test results against its stated reactive capability limits modeled within the PJM EMS. This evaluation will determine which units performed over, under, or within 5% of their stated limits, as well as what follow-up steps are necessary to ensure that the correct information is modeled within the PJM EMS.

Units Testing Within 5% of Stated Limits

Units with test results within 5% of their stated limits will be considered as having fully demonstrated their stated reactive capability.

PJM will notify the MOC that their units achieved their reactive capability, and no further action will be required.

Units Testing Over 5% of Stated Limits

Units with test results over 5% of their stated limits will be considered as having fully demonstrated their stated reactive capability.



PJM will notify the MOC that their units exceeded their stated reactive capability and will propose that they increase the reactive capability modeled within the PJM EMS by entering New-Default eDART MVAR ticket.

Units Testing Below 5% of Stated Limits

Units with test results under 5% of their stated limits will not be considered as having demonstrated their stated reactive capability.

PJM will determine which units not demonstrated due to either internal or external operational limitations based on reasons documented within the submitted test results.

For units that claimed external operational limitations,

- A. PJM will perform further analysis to confirm external limitations and possible remedial measures in the event of future attempts by the MOC to demonstrate the unit's reactive capability.
- B. If an external limitation is confirmed, PJM will provide confirmation to the MOC that their units performed below their stated reactive capability due to external limitations and will not require any further action.
- C. If no external limitation is confirmed, PJM will require that the MOC either permanently reduces the reactive capability modeled within the PJM EMS by entering a -New Default" eDART MVAR ticket or retest to demonstrates the stated capability of the unit.
- D. If the MOC chooses to retest the unit, PJM will require that a temporary eDART MVAR ticket be submitted that will remain active until the unit demonstrates the original stated capability.

For units that claimed internal operational limitations,

- A. PJM will notify the MOC that their units performed below their stated reactive capability
- B. PJM will require that the MOC either permanently reduces the reactive capability modeled within the PJM EMS by entering a -New Default" eDART MVAR ticket or retest to demonstrates the stated capability of the unit.
- C. If the MOC chooses to retest the unit, PJM will require that a temporary eDART MVAR ticket be submitted that will remain active until the unit demonstrates the original stated capability.

Glossary

Scheduled Voltage—The voltage level normally maintained at the system bus during peak load conditions.

Gross Reactive Capability—The maximum sustained overexcited and under-excited reactive output, which generating equipment is expected to produce under normal operating conditions.

Net Reactive Capability at the GSU Primary—The maximum sustained overexcited and under-excited reactive output exclusive of auxiliary usage expected to produce under normal operating conditions.



Net Reactive Capability to the System—The maximum sustained overexcited and under-excited reactive output exclusive of auxiliary usage and GSU reactive power losses expected to produce under normal operating conditions.

GSU (Generator Step-Up Transformer)—An Inductive stationary device that transfers electrical energy from generator voltage to a higher transmission voltage.



Lagging Form R

Net Demonstrated Lagging Reactive Capability Test Data

eDart Ticket # _____
 Company _____
 Plant _____
 Date of Test _____
 Ambient Temperature, F _____
 Normal Hydrogen Pressure, PSIG _____
 Blackstart: Yes No

Reported By _____
 Unit _____
 Time of Test: Begin / End _____ / _____
 Ambient Relative Humidity _____
 Actual Hydrogen Pressure, PSIG _____
 Near-Term Steam: Yes No N/A

Time of Measurement	Instantaneous Gross Gen.		Instantaneous Aux. Power		Net Gen. @ GSU Low-Side		Net Gen. @ GSU High-Side	
	MW	<input type="checkbox"/> MVA _r	MW	<input type="checkbox"/> MVA _r	MW	<input type="checkbox"/> MVA _r	MW	<input type="checkbox"/> MVA _r
Start of Test								
15 min								
30 min								
45 min								
End of Test								
Average of Test**								
Stated Capability								

* Please check boxes for telemetered data

** Average of all test data

Generator Bus Voltages Phase 1 _____ kV Phase 2 _____ kV Phase 3 _____ kV
 Auxiliary Bus Voltages _____ kV _____ kV _____ kV
 System Bus Voltages _____ kV _____ kV _____ kV

Generator Voltage Schedule _____ kV Generator Voltage PT Ratio _____
 System Voltage Schedule _____ kV System Voltage PT Ratio _____

GSU Nameplate Data

Tap Setting: _____ kV Impedance: _____ % Capability: _____ MVA

Remarks: (Plant Limitations)

Remarks: (System Limitations)

Remarks: (Other Limitations)



Leading / Zero Form R

Net Demonstrated Leading / Zero Reactive Capability Test Data

(leading / zero form may not be necessary, depending on unit type)

eDart Ticket # _____ Leading: Zero:
 Company _____ Reported By _____
 Plant _____ Unit _____
 Date of Test _____ Time of Test: Begin / End _____ / _____
 Ambient Temperature, F _____ Ambient Relative Humidity _____
 Normal Hydrogen Pressure, PSIG _____ Actual Hydrogen Pressure, PSIG _____
 Blackstart: Yes No Near-Term Steam: Yes No N/A

Readings are to be recorded as soon as leading / zero limit is encountered

Time of Measurement	Instantaneous Gross Gen.		Instantaneous Aux. Power		Net Gen. @ GSU Low-Side		Net Gen. @ GSU High-Side	
	MW	MVA	MW	MVA	MW	MVA	MW	MVA
Instantaneous								
Average of Test**								
Stated Capability								

* Please check boxes for telemetered data

** Average of all test data

Generator Bus Voltages Phase 1 _____ kV Phase 2 _____ kV Phase 3 _____ kV
 Auxiliary Bus Voltages _____ kV _____ kV _____ kV
 System Bus Voltages _____ kV _____ kV _____ kV
 Generator Voltage Schedule _____ kV Generator Voltage PT Ratio _____
 System Voltage Schedule _____ kV System Voltage PT Ratio _____

GSU Nameplate Data

Tap Setting: _____ kV Impedance: _____ % Capability: _____ MVA

Remarks: (Plant Limitations)

Remarks: (System Limitations)

Remarks: (Other Limitations)



Attachment F: Generator Reactive Capability Test Study Process

Objective

The objective purpose of this attachment is to demonstrate the process which the PJM Reliability Engineers will use to study the feasibility of generator reactive capability test.

Study Process – Example

All generator reactive capability testing will be studied by PJM prior to the scheduled testing date, in accordance with the established PJM procedures.

Each test will also be studied in real-time, prior to the start of the test, in order to verify that there will be no adverse effect on system operations. If it is determined that the testing will cause an actual or post-contingency violation that cannot be mitigated, the testing will be rescheduled.

Purpose:

- The purpose of this example is to demonstrate the process which the PJM Reliability Engineers will use in studying the effects of scheduled generator reactive capability testing, using a large nuclear unit on the PJM 500kv system. This process will be used for day(s)-ahead and real-time studies. This particular example was done using a real-time SE snapshot.
- The purpose of the study is to identify any potential problems caused by the unit's reactive capability testing, and to determine the steps required in mitigating those problems. Any unit reactive capability testing that poses a threat to system reliability or results in off-cost operations will be canceled.

Scenario:

- The case used in this study was a State Estimator case from April 18, 2005, shortly after 0800 hrs. The PJM RTO system load at that time was approximately 66107 MW. There were no post-contingency thermal problems at the time, and the only voltage issues were some post-contingency low voltages in the COMED system and a few marginally high voltage actuals scattered across the system.
- The next exhibit is a screenshot from the PJM EMS showing system voltage actuals prior to testing.

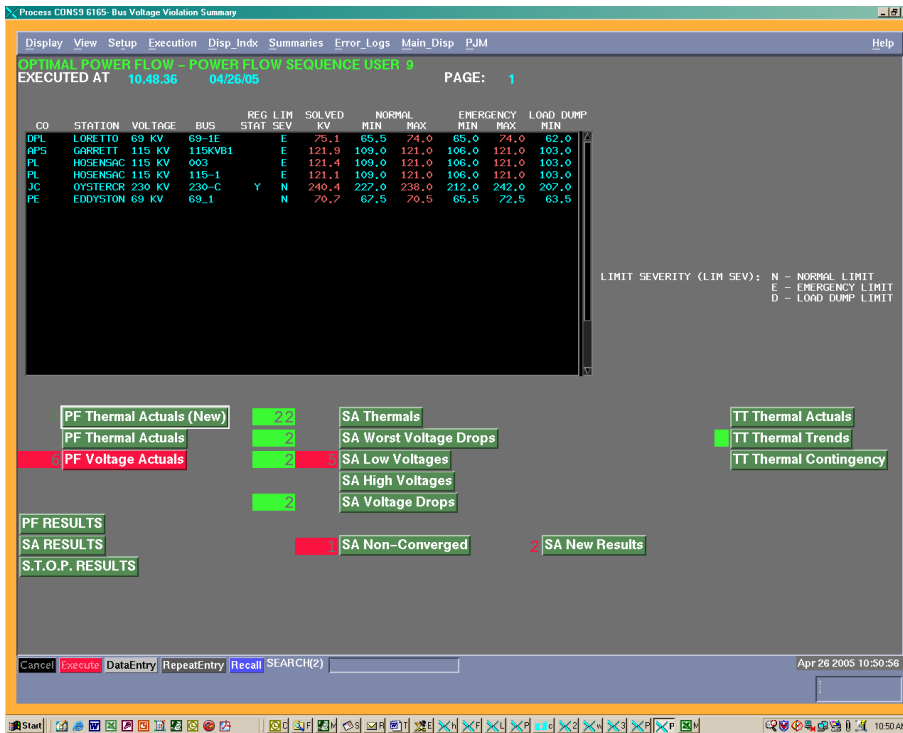

Exhibit 22: Voltage Actuals Prior to Test

- The PJM Reliability Engineers will initiate his study by taking a 'snapshot' of the real-time system. This 'snapshot' will need to be adjusted to reflect anticipated changes to system conditions prior to the scheduled test time.
- In order to correctly model the unit for testing, the PJM Reliability Engineer will need to go to the 'Gen. KV/MVAR Parameter Changes' display and adjust the 'DES. MVAR', 'MVAR MIN' and 'MVAR MAX' to match the maximum rated MVAR output of the unit at the appropriate MW level. This number should match the number verified with the LCC.
- In order to properly recognize mitigation strategies once the MVAR output level has been adjusted, the PJM Reliability Engineer will need to limit the response of the reactive resources in the appropriate transmission zones. This will cause the study case to assume the following:
 - LTC transformers are locked.
 - Phase angle regulators hold a fixed angle.

- Switched capacitors are locked.
- Generators will not control local voltage.
- Load is modeled at constant MW and MVAR.
- This process is the same as when doing an open-ended voltage study. An example display is shown in the exhibit below.

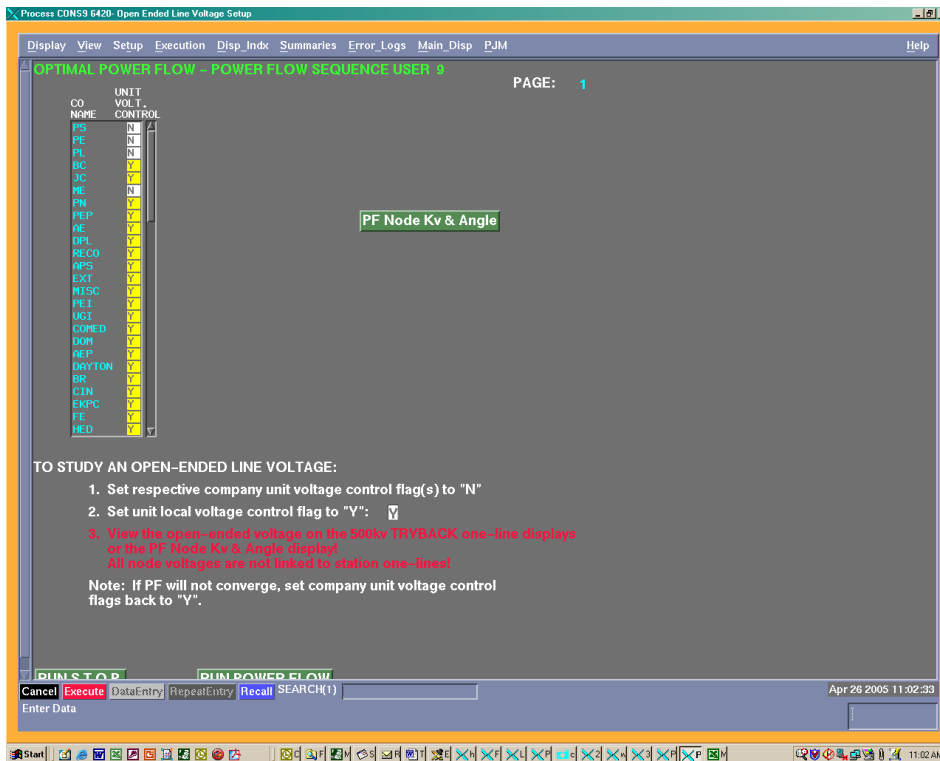

Exhibit 23: Open-Ended Line Voltage Setup Display

- Run power-flow and advanced applications. Once the advanced applications have run, the PJM Reliability Engineer will analyze the results. Example results of voltage actuals, prior to implementing mitigating actions, are shown in the next screenshot.

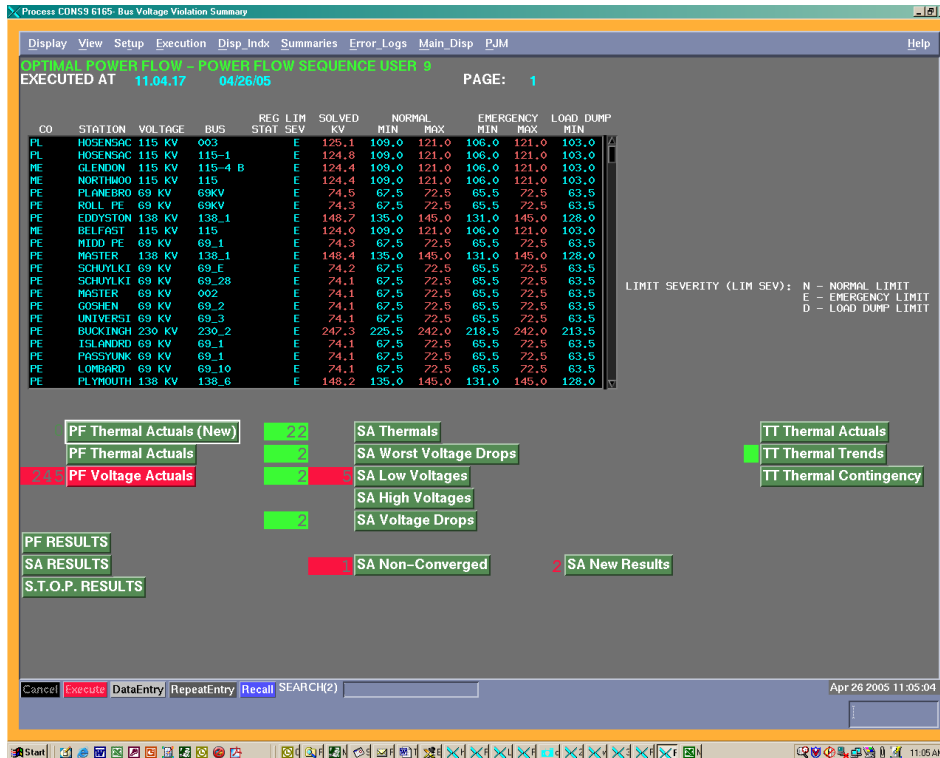

Exhibit 24: Voltage Actuals Prior to Mitigation Steps

- The PJM Reliability Engineer will then determine if the mitigating strategy identified in the day(s)-ahead studies are applicable based on projected system conditions. The PJM Reliability Engineer will finalize a set of recommended mitigation steps to take in order to accommodate the testing, and communicate this strategy with the affected LCC and MOC. The LCC and MOC may raise any concerns or additional issues at that time. Mitigation strategies include adjustments to capacitors, reactors, LTC, or surrounding unit MVAR outputs.
- Once the PJM Reliability Engineer and the LCC have developed and confirmed a set of mitigation steps, PJM will contact the MOC and inform them that mitigation steps must be taken prior to allowing the unit to test. The PJM Reliability Engineer must contact the MOC at least two hours prior to the start of testing.
- The PJM Reliability Engineer and the LCC will take the appropriate actions prior to the unit testing. In this example, 500 kv capacitors at or near the nuclear station were removed from service.

- The resultant voltage actuals, after the mitigation steps, are shown in the next screenshot.

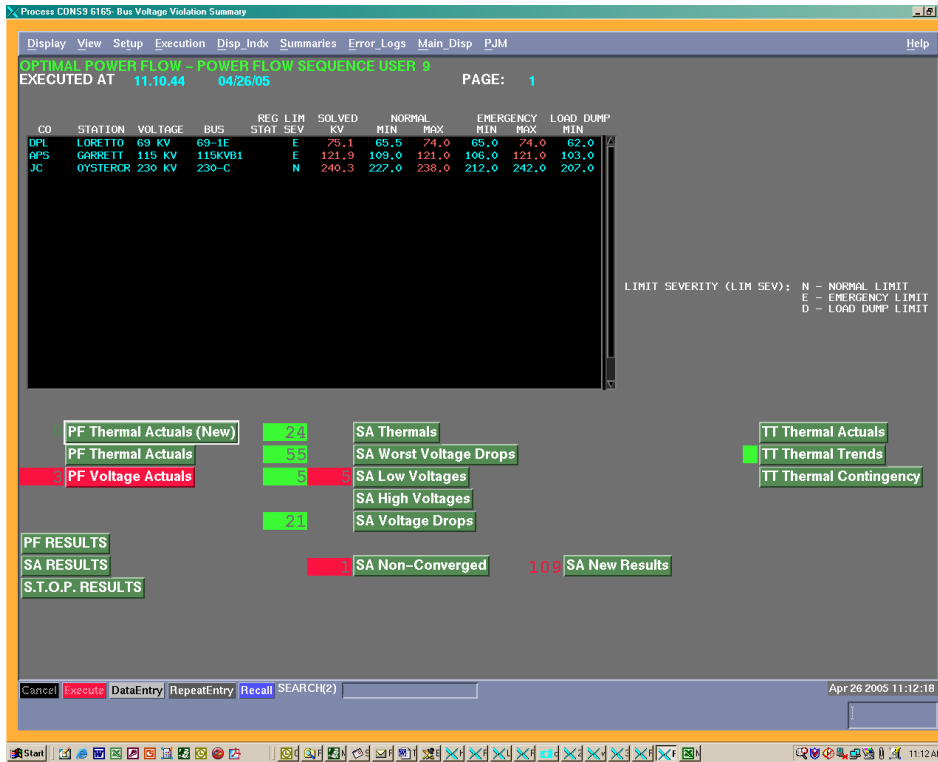

Exhibit 25: Voltage Actuals after Mitigation Steps

- Once the appropriate mitigation steps have been taken, the PJM Reliability Engineer will inform the MOC that their unit is clear for testing.
- The required mitigation steps may need to be implemented in stages, as the unit moves to its full MVAR output level. In this example, as the nuclear unit increases its reactive output, the capacitors would be removed as needed in order to control voltages on the 500kv and 230kv systems.

Note: The mitigation strategy identified in this case may or may not be the strategy selected. Based on projected proximity to the Eastern Reactive Transfer Limit, the strategy selected may have included a combination of removing capacitors from service and reducing local unit reactive output. The PJM Power Director would discuss all possible options with the LCC.

Attachment G: PJM Generator Markets and Operations Process Flow Diagram

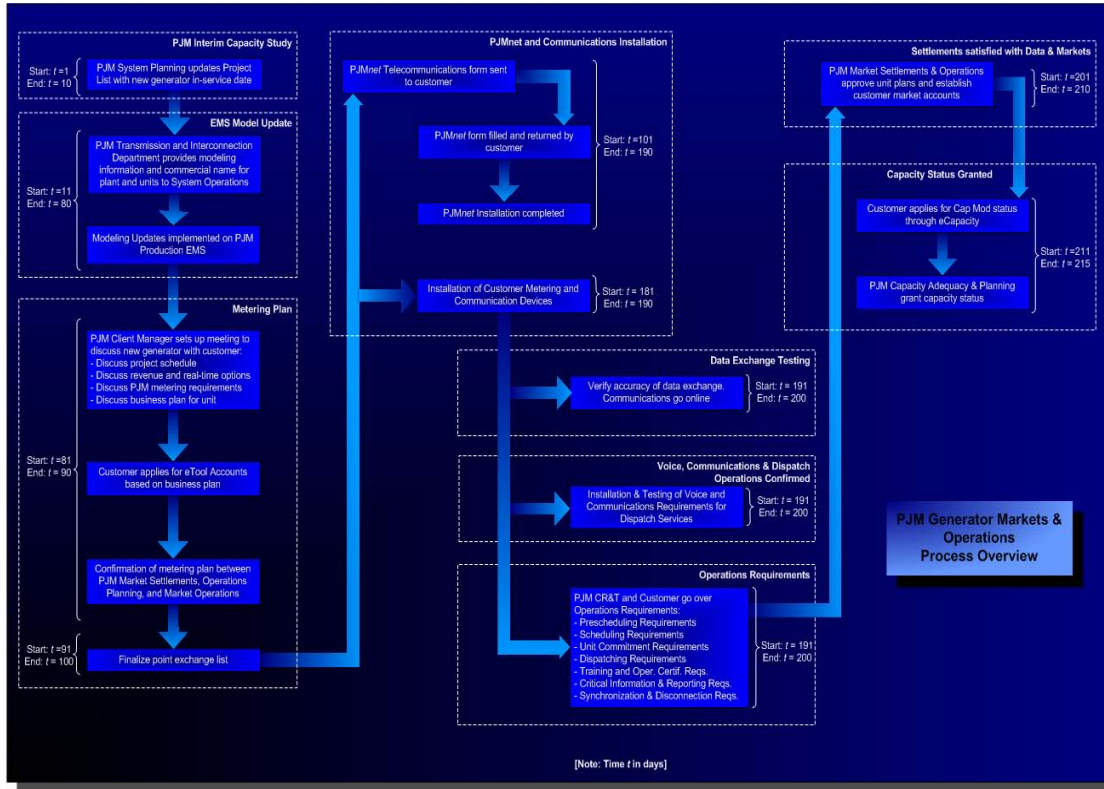

Exhibit 26: PJM Generator Markets and Operations Process Overview



Attachment H: Implementation Team Role Clarity Diagram

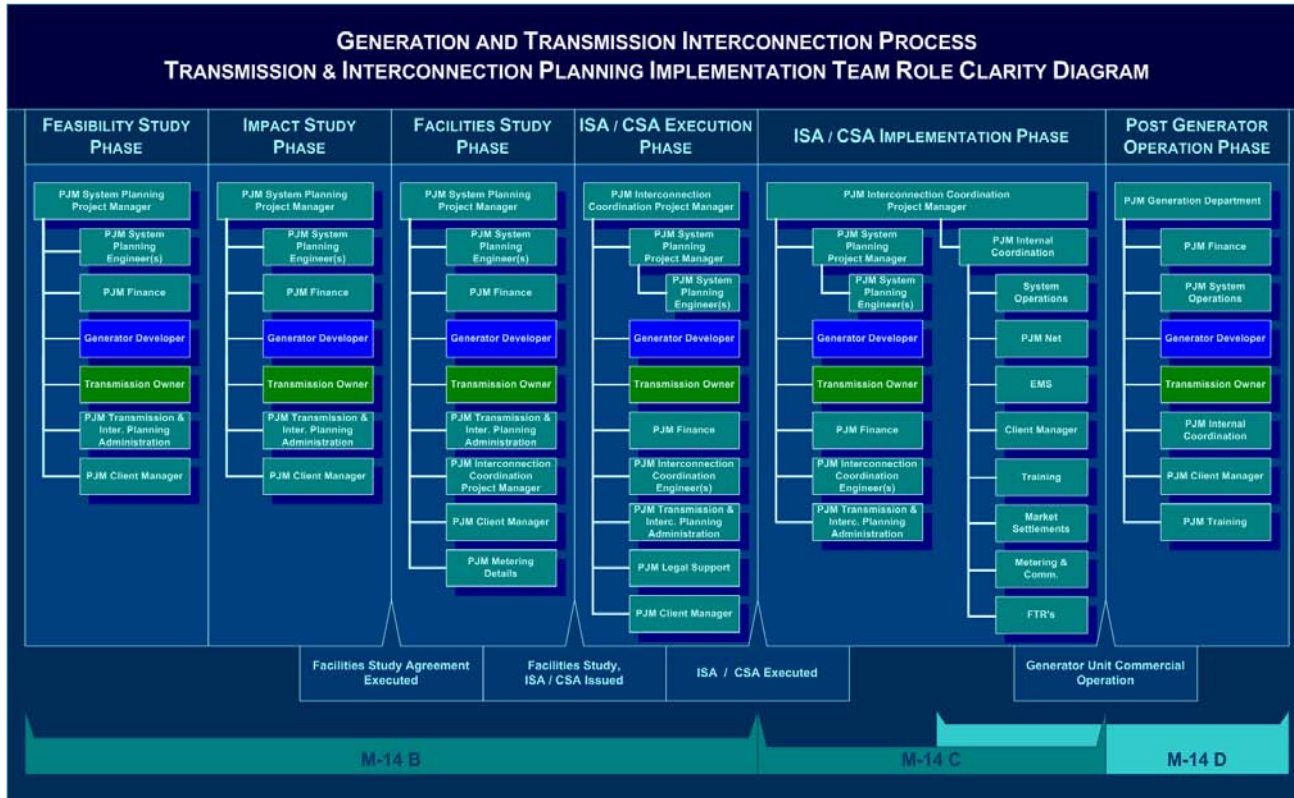

Exhibit 27: Implementation Team Role Clarity Diagram



Attachment I: Generator Data Confidentiality Agreement

**GENERATOR DATA
CONFIDENTIALITY AGREEMENT**

This GENERATOR DATA CONFIDENTIALITY AGREEMENT (“Agreement”) is made and entered into by _____ a (state of organization) (type of organization) (hereinafter “Transmission Owner”), _____ a (state of organization) (type of organization) (hereinafter “Generator”), and PJM Interconnection, L.L.C. a Delaware Limited Liability Company (hereinafter “PJM”) (each may be referred to herein as “Party” or collectively as “Parties”).

WITNESSETH

WHEREAS, Transmission Owner and Generator recognize that, while PJM has the overall power system reliability responsibility in the PJM region, owners of transmission facilities within the PJM region perform certain reliability functions with respect to their individual transmission systems and distribution systems.

WHEREAS, Generator acknowledges that PJM historically has provided certain confidential data regarding Generator’s generating facilities to Transmission Owner, and that the Confidential Information specified in the Generator-Data Release Matrix incorporated herein by reference may be needed to allow the Transmission Owner to perform security analysis and to carry out the reliability functions described above, Generator agrees that PJM may provide such Confidential Information to Transmission Owner pursuant to the terms and conditions of this Agreement.



WHEREAS, Transmission Owner acknowledges that Generator's data, is confidential and must be protected in accordance with the terms and conditions of this Agreement.

WHEREAS, the Parties intend to enter into this Agreement to provide for that data sharing and confidentiality of the data.

NOW, THEREFORE, Transmission Owner, Generator, and PJM agree as follows:

1. Definitions

- a. Confidential Information.** "Confidential Information" is defined as (i) Generator data provided or to be provided by PJM to Transmission Owner regarding Generator's generating facilities pursuant to this Agreement and specified in the Generator-Data Release Matrix, as it may be modified from time to time; and (ii) Generator data already in the Transmission Owner's possession upon the effective date of this Agreement. Confidential Information shall be disclosed only to the entities listed in Section 2.c.1. of this Agreement and only used to enable Transmission Owner to perform Transmission Owner's Reliability Function.
- b. Transmission Function.** ~~Transmission Function~~ is defined as the ~~transmission system operations~~ or ~~reliability functions~~ of the Transmission Owner as those terms are used in the Federal Energy Regulatory Commission's (~~FERC~~) standards of conduct in 18 C.F.R. § 358.
- c. Transmission Owner's Reliability Function.** ~~Transmission Owner's Reliability Function~~ consists of real-time energy management system applications, state estimator and security analyses, monitoring of its transmission system and underlying



distribution system, transmission outage planning, operating reliability and operator training simulator, power flow analyses, contingency operating procedures for peak summer and peak winter load conditions, planned transmission circuit outage feasibility analyses, operating procedure development, and peak load analyses. The Parties may mutually agree to include in the definition of Transmission Owner's Reliability Function additional monitoring responsibilities not listed herein.

- d. **Generator–Data Release Matrix.** The Generator-Data Release Matrix, as it may be modified from time to time pursuant to Section 5 of this Agreement, specifies the Confidential Information that PJM is authorized to provide Transmission Owner pursuant to this Agreement. The Generator-Data Release Matrix is incorporated by reference into this Agreement. The Generator-Data Release Matrix shall include: (i) the name of the Transmission Owner; (ii) the name of the Generator; (iii) the identity of the generating facilities with regard to which PJM is authorized to provide Confidential Information to Transmission Owner pursuant to this Agreement; and (iv) the type of Confidential Information (real time and/or scheduled data) PJM is authorized to provide to Transmission Owner pursuant to this Agreement. The Generator-Data Release Matrix shall be signed by authorized representatives of the Generator and the Transmission Owner. Transmission Owner shall provide PJM with a copy of the initially executed Generator-Data Release Matrix and any modified Generator-Data Release Matrices executed thereafter. In no event will PJM provide Confidential Information to Transmission Owner pursuant to this Agreement prior to receipt of the Generator-Data Release Matrix.



2. Rights and Responsibilities.

a. **Generator's Authorizations.** During the term of this Agreement, Generator authorizes PJM to provide to the Transmission Owner the Confidential Information specified in the Generator-Data Release Matrix, as it may be modified from time to time, pursuant to the terms and conditions of this Agreement.

b. **PJM's Responsibilities.**

1. Upon receipt of the initial Generator-Data Release Matrix and/or any subsequent modified Generator-Release Matrices, PJM shall provide only the Confidential Information as defined in the initial Generator-Data Release Matrix or subsequent modified Generator-Release Matrices to the Transmission Owner. PJM shall provide the Confidential Information as defined in the Generator-Data Release Matrix or subsequent modified Generator-Data Release Matrices on an on-going basis until this Agreement is terminated or superseded.

2. Subject to Section 2.c. of this Agreement, PJM shall provide Confidential Information only to the Transmission Owner's Transmission Function personnel.

c. **Transmission Owner's Rights and Responsibilities.**

1. Transmission Owner shall not disclose Confidential Information to any person except as permitted under this Agreement. Transmission Owner may disclose Confidential Information only to the Transmission Owner's Transmission Function personnel and other employees,



- officers, directors, agents, consultants, contractors, attorneys, accountants, and advisors, including non-employees, (collectively "Representatives"), whose access is necessary, in the reasonable discretion of Transmission Owner, to perform Transmission Owner's Reliability Function or to interpret or implement this Agreement.
2. Section 2.c.1 notwithstanding, consistent with 18 C.F.R. § 358.5, the Transmission Owner shall not disclose Confidential Information to employees engaged in marketing or sales or any employee of any energy affiliate as defined in 18 C.F.R. § 358.3.
 3. Transmission Owner shall be responsible for any breach of this Agreement by any of its Representatives. Transmission Owner promptly shall notify Generator and PJM of any actual or suspected breach of this Agreement by Transmission Owner or any of its Representatives. Such notification shall include the nature and cause of the breach, the Confidential Information that was disclosed, the identity of the persons involved, and actions taken by Transmission Owner to correct or mitigate the breach.
 4. The Transmission Owner may disclose Confidential Information only to Representatives who have been informed of both the confidentiality restrictions contained in this Agreement and who have executed a Confidentiality Agreement Certification ("Certification") (a pro forma form of which is attached) under which they are bound by the terms and conditions of this Agreement.



5. Transmission Owner may use the Confidential Information only for the purpose of performing Transmission Owner's Reliability Function and shall not otherwise use the Confidential Information for its own benefit or for the benefit of any other person.
6. Transmission Owner does not, by virtue of this Agreement or otherwise, acquire any right title, or any interest of any kind in the Confidential Information. All Confidential Information shall remain the property of Generator. No license or other right under any patent or other proprietary right is granted or implied by the conveyance of the Confidential Information.
7. At Generator's expense, upon reasonable notice, during business hours, and at a date and time reasonably agreed upon by the Generator and Transmission Owner, Transmission Owner shall permit the Generator, and Generator shall have the right, to audit compliance with this Agreement to the extent reasonably necessary and remove all Confidential Information not destroyed in compliance with this Agreement. The Generator's right shall include the right to examine the records of Transmission Owner but not the right to examine information relating to other entities that own generating or transmission facilities.
8. Notwithstanding anything in this Agreement to the contrary, if required by applicable law or in the course of administrative or judicial proceedings, except for FERC proceedings, to disclose to a third party Confidential



Information, Transmission Owner shall be permitted to make disclosure of such Confidential Information; provided, however, that as soon as reasonably practicable after the Transmission Owner learns of the disclosure requirement and prior to making disclosure, Transmission Owner shall notify Generator of the disclosure requirement and Generator may direct, at its sole discretion and cost, any challenge to, or defense against, the disclosure requirement and Transmission Owner shall cooperate to the maximum extent practicable to minimize the disclosure of Confidential Information consistent with applicable law. In the event that the FERC or its staff, during the course of an investigation or otherwise, requests Confidential Information from Transmission Owner, Transmission Owner shall provide the requested Confidential Information to the FERC or its staff; provided that, consistent with 18 C.F.R. § 388.112, Transmission Owner must request that the Confidential Information be treated as confidential and non-public by the FERC and its staff and that the information be withheld from public disclosure. Transmission Owner shall notify Generator when it is notified by FERC or its staff, that a request for disclosure of, or decision to disclose, Confidential Information has been received, at which time Generator may respond before such Confidential Information would be made public, pursuant to 18 C.F.R. § 388.112.

9. Transmission Owner shall maintain a current list of all Representatives, (including their job titles, duties and responsibilities, employee or contract status, and the name



of the organization for which they are employed) who have signed the Certification and thereby are permitted access to the Confidential Information. Transmission Owner shall provide this list to Generator and PJM initially within 30 days of the execution of this Agreement and thereafter upon request. The Generator may challenge whether the Transmission Owner's release of the Confidential Information to Representatives on the above-described list is consistent with the terms of this Agreement by providing written notice to the Transmission Owner including the rationale for the challenge. Any dispute arising under this section shall be resolved pursuant to the PJM dispute resolution procedures set forth in Schedule 5 of the Amended and Restated Operating Agreement of PJM Interconnection, L.L.C., as may be amended from time to time (~~PJM Operating Agreement~~).

10. Subject to Subsection 2.c.8 above, Transmission Owner shall protect and keep confidential all Confidential Information it receives from PJM. It may, copy, post, distribute, disclose or disseminate the Confidential Information only in the following manner. Transmission Owner may make a limited number of copies of written or electronic materials to enable Transmission Owner adequately to use the Confidential Information within the terms and conditions of this Agreement. If the Transmission Owner prints or electronically conveys any Confidential Information, it shall protect each copy as Confidential Information in accordance with this Agreement and mark each copy as ~~Confidential Information~~." In no



event shall the Transmission Owner protect Confidential Information using standards that are less stringent than those standards that the Transmission Owner employs in protecting its own confidential or proprietary information.

11. Upon the completion of the use of Confidential Information for the purpose of performing Transmission Owner's Reliability Function, the Transmission Owner shall destroy all Confidential Information no longer needed for the Transmission Owner's Reliability Function analyses or studies. Transmission Owner shall ensure that best efforts have been undertaken to destroy the Confidential Information.

3. **Dispute Resolution.** If, at any time during the term of this Agreement, any Party questions whether any other Party is breaching the terms of this Agreement, or any dispute arises under the terms of this Agreement, either Party may request mediation using the same procedures laid out in PJM's dispute resolution procedures (Schedule 5 of the PJM Operating Agreement). No Party shall take any action contrary to this Agreement unless and until allowed to do so as the result of such mediation.
4. **Modification to Agreement.** No Party shall have the unilateral right to modify the terms of this Agreement or the Generator-Data Release Matrix.
5. **Modification to Generator-Data Release Matrix.** The Generator-Data Release Matrix may be modified from time to time by the Generator and the Transmission Owner pursuant to procedures set forth in this Section 5. Such modifications may include adding or deleting generating facilities with regard to which PJM will provide Confidential Information to



Transmission Owner and/or the type of Confidential Information relating to the specified generation facilities that PJM is authorized to provide Transmission Owner. The respective designated PJM Operating Committee representative for the Transmission Owner and the Generator shall be authorized to approve and execute the initial Generator-Data Release Matrix, and to make any subsequent modifications thereto on behalf of the Transmission Owner and Generator respectively. In the event Transmission Owner or Generator does not have a PJM Operating Committee representative, then its Members Committee representative shall be authorized to approve and execute the initial Generator-Data Release Matrix and any subsequent modified Generator-Data Release Matrices. Any Generator-Data Release Matrix modified pursuant to this Section 5 shall be incorporated by reference into this Agreement and execution of a separate Generator Data Confidentiality Agreement will not be required. All Confidential Information provided Transmission Owner pursuant to a modified Generator-Data Release Matrix is Confidential Information as defined in this Agreement and must be treated and maintained under the terms and conditions of this Agreement. Transmission Owner shall provide PJM with any Generator-Data Release Matrices modified pursuant to this Section 5. PJM shall provide Transmission Owner only with the Confidential Information specified in the most recent Generator-Data Release Matrix in its possession.

6. **Assignment.** This Agreement may not be assigned, delegated, or transferred by any Party without the other Parties' written consent provided, however, that any Party may, without the consent of the other Parties, assign its rights and obligations under this Agreement to an entity that becomes its successor in interest by acquiring all, or substantially all, of such Party's assets through merger, consolidation,



sale, foreclosure, or corporate reorganization. Such consent shall not be unreasonably withheld or delayed. This Agreement shall bind the successors and assignees of the Parties to this Agreement.

7. Term.

This Agreement shall become effective on the date executed and remain effective until superseded or terminated by mutual agreement of the Parties.

8. Survival of Confidentiality.

The terms and conditions of this Agreement with regard to treatment of Confidential Information under this Agreement shall remain in effect until the Confidential Information is destroyed pursuant to the terms of this Agreement, and shall survive the termination of this Agreement until such time as all Confidential Information protected under the terms and conditions of this Agreement is destroyed. Termination shall be prospective only and shall not affect any obligation of the Parties with respect to Confidential Information provided to Transmission Owner prior to the effective date of this Agreement or pursuant to the this Agreement. Notwithstanding the effective date of this Agreement, any Confidential Information disclosed by PJM to the Transmission Owner prior to such effective date shall be deemed Confidential Information pursuant to the terms hereof.

9. Agreement Not Applicable. Nothing herein shall apply to any Confidential Information that:

- a. after disclosure by Transmission Owner, Confidential Information entered the public domain without any action or fault of the Transmission Owner;



- b. is obtained from any individual, firm or entity which had the unrestricted right to disclose it;
- c. is required to be publicly disclosed under court or governmental order, subject to compliance with the procedures set forth in Section 2.c.11 hereof.

10. Remedies.

- a. Transmission Owner and Generator understand and agree that monetary damages may not be an adequate remedy for a breach of this Agreement. Any monetary damages as a result of a breach of this Agreement shall be limited to one million dollars, which shall include any and all damages, including, but not limited to, punitive and legal fees or expenses or costs incurred in enforcing this Agreement, or recovering damages from any breach hereof. In the event of any breach or threatened breach by either Generator or Transmission Owner, the other Party shall be entitled to injunctive and other equitable relief, and that there shall be no pleading in defense thereto that there would be an adequate remedy at law. Such remedy shall be in addition to all other remedies available to it at law, or in equity.
- b. Notwithstanding anything in this Agreement to the contrary, PJM shall not be liable for any claims, demands or costs arising from, or in any way connected with its performance under this Agreement, other than actions, claims or demands based on gross negligence or willful misconduct. Any monetary damages as a result of any such action, claim or demand against PJM based on gross negligence or willful misconduct shall be limited to one million dollars, which shall include any and all damages including but not limited to punitive damages and legal fees or



expenses or costs incurred in enforcing this Agreement, or recovering damages from any breach hereof.

11. **Entire Agreement.** This Agreement along with the Generator- Data Release Matrix, as it may be modified from time to time, incorporated by reference herein constitute the entire Agreement between the Transmission Owner, Generator, and PJM regarding the subject matter hereof, and shall not be subject to change or amendment except in writing signed by authorized representatives of the Transmission Owner, Generator, and PJM. All provisions of this Agreement are severable, and the unenforceability of any provision shall not affect the validity or enforceability of the remaining provisions.
12. **Relationship to Other Agreements.** This Agreement supersedes the Interim Generator Data Confidentiality Agreement executed by the Parties. This Agreement does not supersede any existing generation interconnection agreements or other agreements in effect between the Transmission Owner and the Generator that govern the treatment of exchanged generator data. This Agreement also does not preclude the Generator and Transmission Owner from entering into a separate agreement regarding the exchange of generator data not included in the Generator-Data Release Matrix.
13. **Authority to Enter into this Agreement.** Transmission Owner, Generator, and PJM each represent and warrant that it has full legal authority to enter into this Agreement and to abide by the terms and conditions of, and fulfill the responsibilities set forth in, this Agreement
14. **No Waiver.** No failure or delay by either Transmission Owner, Generator, or PJM in exercising any right, power or privilege hereunder shall operate as a waiver thereof, nor shall any single or partial exercise



thereof preclude any other or further exercise of any other right, power or privilege hereunder.

15. **Notices.** Communications shall be sent to the Parties at the addresses indicated herein, or to such other address as either Party may specify in writing.
16. **No Warranties/Relationship of the Parties.** Generator makes no, and shall not be deemed to have made any, covenant, warranty or representation as to the accuracy or completeness of any Confidential Information disclosed by it. Generator shall not have any liability relating to or arising from Transmission Owner's use of any Confidential Information. This Agreement does not establish a partnership, agency, joint venture or similar relationship, obligate either Party to enter into such a relationship, and/or constitute any agreement by the Parties not to compete.
17. **Counterparts; Facsimile Execution.** This Agreement may be executed in counterparts, with each executed counterpart having the same force and effect as the original counterpart. This Agreement shall be deemed binding upon the Parties if each Party executes this Agreement, sends the executed Agreement via facsimile to the other Parties, and receives confirmation of receipt of the executed Agreement from the other Parties.
18. **Applicable Law.** Pennsylvania law applies to this Agreement and any disputes arising thereunder resulting in litigation shall be litigated in the courts of Pennsylvania.



IN WITNESS WHEREOF, Transmission Owner, Generator, and PJM have caused this Agreement to be executed by their respective authorized officials.

TRANSMISSION OWNER

By: _____
Name Title Date

GENERATOR

By: _____
Name Title Date

PJM INTERCONNECTION, L.L.C.

By: _____
Name Title Date



CONFIDENTIALITY AGREEMENT CERTIFICATION

I [name] hereby certify that Confidential Information is being provided to me pursuant to the terms and restrictions of the Generator Data Confidentiality Agreement dated _____ between [Transmission Owner] and [Generator] and PJM Interconnection, L.L.C. (“Confidentiality Agreement”) and I agree to be bound by the terms and conditions of the Confidentiality Agreement. I understand that the Confidential Information, including any portion of any notes, memoranda, studies, or any other writing that I or [Transmission Owner] creates and that contains information from the Confidential Information, shall not be disclosed to anyone other than in accordance with the terms and conditions of the Confidentiality Agreement, and shall be used only for the purpose of performing Transmission Owner’s Reliability Function. My obligation under this Confidentiality Agreement Certification shall survive my termination or change of duty or employment status.

Printed Name: _____

Signature: _____

Title: _____

Company/Organization: _____ Date: _____



**Attachment K: Template Letter for a Transmission Owner Seeking
Generator Data Within its Zone to be Released by PJM**

[TO Company Name]
[TO's Street Address]
[TO's City, State, and Zip Code]
[Date]

[GO Representative Name]
[GO Company Name]
[GO's Street Address]
[GO's City, State and Zip Code]

To [GO Representative Name]:

In order for [TO Company Name] to perform reliability analysis, we require PJM to provide us generator data that your company provides to PJM. Your generator lies within our transmission zone and this information is integral to the reliability analysis that we must perform to ensure the transmission grid remains reliable.

Please authorize PJM Interconnection to release to [TO Company Name] the generator data that is within our transmission zone. We request this data for each of the following units: [List generator units here]. Please sign three copies of this letter and send two of them to PJM, addressed to the Manager of the Power System Coordination Department. PJM will retain one of the data release authorization forms and send the other form to the initiating transmission owner. PJM's Law Department will keep a record of this data release authorization form

Sincerely,

TO Officer Signature
[TO Officer Name]
[TO Company Name]

Generator Owner Authorization

I authorize PJM to provide the above requested generation data to [TO Name].

GO Officer Signature
[GO Officer Name]
[GO Company Name]

Attachment L: Wind Farm Communication Model

Manual dispatch directives to multiple wind owners delay controlling actions resulting in less efficient market operations and a potential adverse impact to system reliability. Manual dispatch to a subset of owners at a common Wind Farm may result in customers questioning curtailments and additional administrative procedures to ensure fair/equitable reductions to an aggregate plant on a rotating basis. A single SCED basepoint for a Wind Farm to a single MOC Generation System Operator is an effective solution to ensure efficient and reliable operations.

The purpose of this section is to define a dependable real-time communications model to manage wind, ensuring:

1. A single MOC Generation System Operator (single operational contact) for the processing of all real-time dispatch electronic signals and operational issues.
2. Accurate outage data, which is essential for an accurate Wind Power Forecast
3. Prompt wind reduction, which typically would occur as a last resort just prior to emergency procedures.

Note 1: This communication model may be expanded to include other renewable resources as PJM develops forecast tools or their penetration levels increase.

Note 2: The MOC Generation System Operators (single operational contact) will need to meet the PJM certification and training requirements outlined in PJM Manual 40: Certification and Training Requirements.

Option 1: PJM Operations would prefer a model where there is a single MOC Generation System Operator (single operational contact) responsible for the entire Wind Farm operations. The single contact would be responsible for all day-ahead and real-time bidding into PJM Systems (eMkt), process an SCED basepoint, real-time communications with PJM Dispatch, as well as providing accurate turbine outage information within eDart. Settlements can be allocated by PJM based on ownership shares.

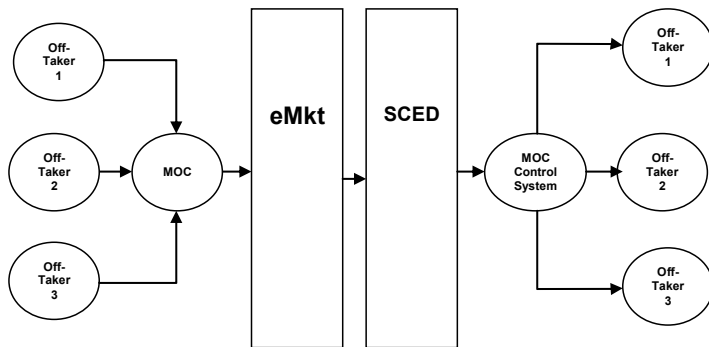

Exhibit 28: Wind Farm Communication Model 1

Option 2: The alternate solution would still require a single MOC Generation System Operator (single operational contact), however, each owner/off taker would still be able to interact with eMkt, providing day-ahead bids and hourly updates. The single operational contact would be responsible for processing SCED basepoints, all real-time communications with PJM Dispatch, as well as providing accurate turbine outage information within eDart. PJM SCED would send individual basepoints to each owner/off taker as well as sending an aggregate base point to the operational contact. Settlements will model individual owner/offtakers.

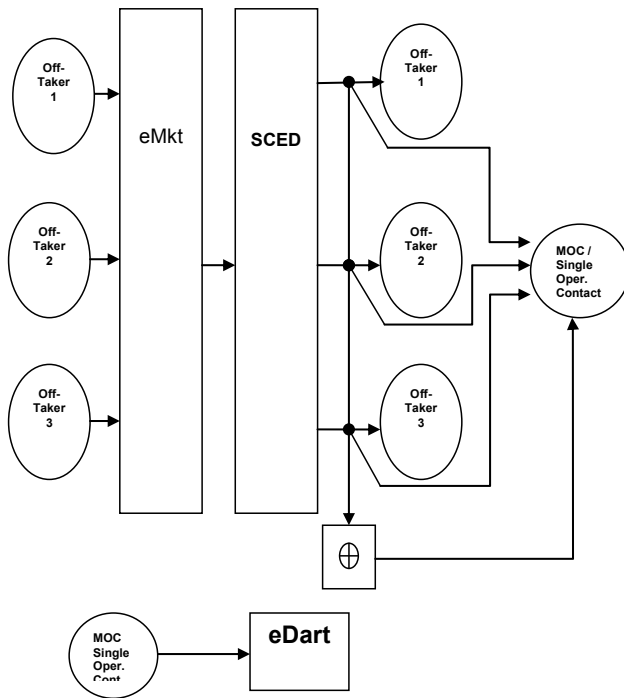

Exhibit 29: Wind Farm Communication Model 2



APPENDIX A: Behind the Meter Generation Business Rules

Definition and Purpose of Behind-the-Meter Generation (BtMG)

- (1) The purpose of these rules is to permit market participants operating Behind-the-Meter Generation (BtMG) to receive the associated benefits. These benefits are recognized by allowing such generation to net for the purposes of calculating transmission, capacity, ancillary services, and administrative fee charges.
- (2) The netting rules for BtMG are set forth in the PJM Open Access Transmission Tariff (-PJM Tariff"), the Amended and Restated Operating Agreement of PJM Interconnection, L.L.C. (-Operating Agreement"), and the Reliability Assurance Agreement Among Load Serving Entities in the PJM Region (-RAA"). These documents filed with the Federal Energy Regulatory Commission will take precedence in the event of any conflict or ambiguity between these rules and the filed documents.

Eligibility for BtM Netting

- (3) These rules apply to BtMG used by end-use customers, municipal electric systems, electric cooperatives, and electric distribution companies to serve load. The load must be located at the same electrical location as the BtMG, such that no transmission or distribution facilities are utilized to transmit energy from the BtMG to the load. An exception to the prohibition on use of distribution facilities rule is allowed, in cases where permission to use the requisite distribution facilities has been obtained from the owner, lessee, or operator of such facilities. Such permission must be submitted in writing to PJM from the owner, lessee or operator of such distribution facilities.
- (4) BtMG netting is only available to entities that have Network Integration Transmission Service agreements with PJM.
- (5) These business rules do not supersede any elements of existing retail service agreements or standby service agreements between an entity and its Load Serving Entity or the Electric Distribution Company to which the associated load is connected.

BtM Netting – General Rules

- (6) BtMG does not include at any time, any portion of a generating unit's capacity that is designated as a Capacity Resource; or in any hour, any portion of the output of such generating unit that is sold to another entity for consumption at another electrical location or into the PJM Interchange Energy Market.
- (7) Generation Owners shall not be eligible to receive payments, pursuant to Schedule 2 of the PJM Tariff, for reactive service for portions of generating units upon becoming a BtM Generator. Generation Owners subject to this rule shall cooperate with PJM in making any regulatory filings that may be required to implement this rule.
- (8) The need for metering for small BtMG will be treated on a case-by-case basis, depending on local operational security needs. For the purposes of this rule, small BtMG shall be individual generating units that are less than 10 MW, or multiple generating units that are collectively less than 10 MW. Generally, these units will not



require metering for operational security purposes. Rules for metering are detailed in the PJM Manual for Generator Operational Requirements (M-14D).

- (9) BtMG that is 10 MW or greater (or has been identified as requiring metering for operational security reasons) must have both revenue metering and telemetering for operational security purposes. Single unit small BtM generators that collectively total more than 10 MW, may be aggregated behind the meter and metered as a single unit to meet this requirement should PJM require metering for the aggregate generation. Rules for metering are detailed in the PJM Manual for Generator Operational Requirements (M-14D).
- (10) BtMG will be recognized in PJM transmission and generation adequacy planning models. Load and generation will be modeled separately where practicable.
- (11) If multiple generation units are located behind the meter, each unit can be designated as either a Capacity Resource or as BtMG on a unit specific basis or on a partial unit basis.
- (12) A party may change all or a portion of a unit's capability from Capacity and/or Energy Resource status to BtMG status, or from BtMG status to Capacity and/or Energy Resource status (provided the generator has met the applicable requirements for Capacity Resource status), but cannot be used for both purposes simultaneously for a designated portion of a unit's capability. Any portion of a unit that has been qualified as a Capacity Resource is subject to the same requirements as any other PJM Capacity Resource. Because of the number of procedural requirements associated with changing to or from BtMG status, such changes shall be limited to once per year in accordance with the schedule set forth below.
- (13) A Capacity Resource that changes to BtMG, or a new generator that requests BtMG status will be able to net its full installed capacity value for the first calendar year for transmission and the first Planning Period for capacity. The netting value for all succeeding years will be based on actual generator performance over the 5 CP and 1 CP days.
- (14) Requests for BtMG changes for transmission charges, black start service, and reactive service must be received by PJM by December 1 and will become effective the following January 1. The change shall remain in effect for a period no less than one calendar year.
- (15) Requests for BtMG changes for capacity obligations must be received by PJM by December 1 and will become effective the following June 1. The change shall remain in effect for a period no less than one Planning Period.
- (16) Requests for BtMG changes for energy-based ancillary service charges (i.e., those ancillary services charged on a MWh basis such as regulation, spinning and operating reserves) and for administrative fee charges can be made anytime. The change will become effective on the first of the month following PJM's communication that all logistical modifications (as may be required, for example, to metering or billing/settlement records) have been completed. The change shall remain in effect for a period no less than 12 months from the month the change becomes effective.
- (17) If a generator is granted BtMG status for one purpose (such as capacity), it must become BtMG for all other purposes described in Rules 14, 15 and 16 above, and in accordance with the timetables established in those rules. A generator that changes its



status to BtMG pursuant to Rules 14 and 16 will be deemed to have given notice pursuant to Rule 15 to request BtMG status for capacity obligations for the Planning Period immediately following the Planning Period in which the Rule 14 and/or 15 BtMG request was made/effective., so as to comply with the notice requirements provided in Section 2.5.2 of the PJM Tariff.

- (18) The timing requirements established in Rules 14, 15 and 16 are not affected by a transfer of ownership; BtMG status changes are only permitted according to the timetable described in Rules 14, 15 and 16 above.
- (19) If Non-Retail BtMG is subject to a reduced netting credit as described in Rule 34 below, that generator is ineligible to change its behind the meter status until the full effect of that reduction has been fully rolled out.
- (20) If a Capacity Resource moves behind the meter, its injection rights will be treated the same as if the unit had been deactivated. Those injection rights are defined in Section 230 of the PJM Tariff, generally, and Section 230.3.3 specifically with respect to rights that apply if a generation resource is deactivated.

Participation in Load Management Programs

- (21) BtMG may participate in all relevant PJM demand side response programs (e.g. the PJM Interchange Energy Market and the PJM Capacity Market (RPM)) under the terms and conditions in effect at the time the BtMG requests participation in the program, subject to Rule 22 below.
- (22) A generator may be used for Load Management (LM) credit or it can be used to net against load as a BtM generator, but cannot be used for both purposes simultaneously. The election of BtM or LM status must remain in effect for an entire planning period.
- (23) A BtM generator may participate in the PJM Load Response programs under the terms and conditions in effect at the time the BtM generator requests to participate in the program.

Generation Netted Against Load

- (24) The load associated with BtMG must have a Load Serving Entity (LSE). The LSE will be responsible for supplying energy, capacity, ancillary services and transmission for that portion of the load not supplied by the BtMG. For the purposes of this rule, the load not supplied by the BtMG shall include load normally supplied by the BtMG during periods when the BtMG is not operating.
 - a. The capacity obligation for the load will be based on the average of the net load at the site(s) (gross load minus operating BtMG, not to be less than zero) at the time of the Zone's transmission peak (1CP) during the five (5) coincident peak hours, in accordance with the 5CP methodology in effect for the Zone.
 - b. Network Integration Transmission Service charges will be calculated as the net load at the site(s) (gross load minus operating BtMG, not to be less than zero) at the time of the Zone's transmission peak (1CP).



- c. Regulation and Spinning Reserve obligations will be calculated based on the net MWh of load at the site (hourly gross load minus operating BtMG, not to be less than zero) in real time.
 - d. Day-Ahead Operating Reserves will be charged based on the net amount of load at the site(s) that clear(s) in the PJM Day-Ahead energy market.
 - e. Balancing Operating Reserve deviations will be measured based on the net change of both the BtMG and the load between day-ahead and real-time.
 - f. PJM Schedule 9 administrative fees based on real time load and generation will be charged on the net value of load or generation as measured in real time.
- (25) Under this “netting” arrangement, the EDC and/or LSE will be responsible for reporting both the load and generation information to PJM for use in the load forecast for generators for which metering is required for operational security purposes. The EDC may need to obtain this information from the LSE and both parties are required to cooperate to ensure PJM receives the information.
- (26) For wholesale market participation, the interconnection requirements will be publicly available and, in cases where parallel operation will exist with the distribution or transmission system, determined by the EDC in accordance with applicable state or other jurisdictional requirements. The generator will be evaluated using the PJM interconnection process only if it is involved in a wholesale transaction.

BtM Netting – Non-Retail Participation

- (27) Non-Retail BtMG netting provisions apply to behind the meter generation used by municipal electric systems, electric cooperatives, and EDCs to serve load, provided that, if distribution facilities are used to deliver energy from Non-Retail BtMG to load, then permission to use such distribution facilities has been obtained from the owner, lessee, or operator of such distribution facilities. Such permission shall be submitted to PJM in writing from the owner, lessee or operator.
- (28) All entities using the Non-Retail BtMG option must have a Network Integration Transmission Service agreement with PJM.
- (29) Non-Retail BtMG netting is subject to a threshold amount. The Non-Retail BtMG threshold is 1,500 MW for calendar year 2006 for transmission charges, black start service, and reactive service, and for the 2006/2007 Planning Period for capacity obligations. Each year thereafter, the Non-Retail BtMG threshold will be increased based on PJM RTO load growth. PJM RTO load growth will be determined based on the most recent forecasted weather-adjusted coincident summer peak divided by the weather-adjusted coincident peak for the previous summer. After applying the load growth factor, the Non-Retail BtMG threshold will be rounded to the nearest whole MW, and that rounded number will be the Non-Retail BtMG threshold for that current year or Planning Period and the base amount for calculating the Non-Retail BtMG threshold for the succeeding year or Planning Period.
- (30) PJM shall communicate a change in the Non-Retail BtMG threshold through an email to all BtM generators and posting on the PJM website.
- (31) If the amount of Non-Retail BtMG netting exceeds the Non-Retail BtMG threshold, the amount of Non-Retail BtMG shall be prorated back to the threshold. In such instance,



the amount of Non-Retail BtMG eligible for netting by an entity shall be the product of its total Non-Retail BtMG multiplied by the ratio of the Non-Retail BtMG threshold divided by the total amount of the Non-Retail BtMG in the PJM RTO (not to exceed 3,000 MW). [Example: if the Non-Retail BtMG threshold is 1,500 and the total amount of Non-Retail BtMG netting in the PJM RTO reaches 2,000, then 75 percent of an entity's Non-Retail BtMG would be eligible for netting.]

- (32) The total amount of Non-Retail BtMG eligible for netting under the BtMG provisions is capped at 3,000 MW. If this cap is reached, no additional Non-Retail BtMG will be eligible for netting. Furthermore, within six months of reaching the cap, PJM shall file with the FERC to justify either continuation of the existing BtMG rules (including any expansion of the rules to include additional MW) or any change to the rules.
- (33) Each calendar year, netting Non-Retail BtMG resources shall be required to operate during the first ten occurrences of Maximum Emergency Generation (MEG) conditions in the zone in which the resource is located. This obligation applies to an MEG condition called for either generation or transmission emergencies. Notice of an MEG event shall be communicated through the PJM all-call system.
- (34) For each MEG condition in which netting Non-Retail BtMG is not on a scheduled outage but fails to operate, in whole or in part, the netting associated with that resource for purposes of charges for transmission service, reactive service, black start service, and capacity obligations will be reduced by ten percent of the amount of megawatts the resource failed to produce. The amount of megawatts that the resource failed to produce will be the difference between its full netting credit and its megawatt average output over the MEG period. [Example: if a netting Non-Retail BtM resource is required to operate with an output of 100 MW during a Maximum Emergency Generation condition, but only operates to a level of 75 MW, in the next year, the eligible netting from that resource will be reduced by 2.5 MW, which is the product of the following calculation: $[(100 - 75) \times .10]$].
- (35) Any reductions in netting will be applied in the succeeding calendar year with regard to transmission service, reactive service, and black start service, and the succeeding Planning Period with regard to netting related to capacity obligations.
- (36) A generator that moved behind the meter is not eligible to move back in front of the meter until the impact of the reduced netting penalty described in Rule 34 above has been rolled out.
- (37) Non-Retail BtMG may not schedule a unit outage in the months from June through September.

BtM Adjustment Process

- (38) Parties seeking a BtMG adjustment of any type must notify PJM at BTMG@pjm.com. The BtMG request must contain the following information:
 - Contact name, company, email address and phone number
 - Name of generation unit(s) and EIA plant and unit identification numbers
 - Summer net dependable rating of the unit(s)
 - Name of the applicable Load Serving Entity and Electric Distribution Company



- If applicable, written approval from the owner, lessee or operator of a distribution facility used to deliver energy from the BtM generator to load
 - For non-retail BtM generation, the phone number to be added to the PJM all-call list
- (39) PJM will respond to the request and coordinate data and information flow between all affected parties (customer, LSE, EDC, etc.) to determine eligibility, peak load adjustments, etc.



Revision History

Revision 19 (10/01/2010):

- Incorporated Wind Farm Communication Model as Attachment L.

Formatted: Outline numbered + Level: 1 +
Numbering Style: Bullet + Aligned at: 0.25" +
Tab after: 0.25" + Indent at: 0.5"

Revision 18 (June 1, 2010):

- Revised Attachment D, E, and F to remove redundancy and reorder.
- Modified Attachment E to change requirement to submit completed PJM Leading and/or Lagging Test Form R to PJM within 30 calendar days after completion of the testing (changed from 10 days).
- Added bullet 7 under Section Data Requirements in Attachment D, ~~Company can either test or apply the best engineering judgment to construct D-curve at min load points.~~
- Added a line in Bullet 5 under Section Testing Requirements for both Units Larger than 70 MW and Black Start Units in Attachment E, ~~This requirement may require a departure from scheduled voltage during the test, provided no adverse effect on the validity of test results can be demonstrated.~~

Revision 17 (01/01/2010):

- Updated section 7.1.2 – language for voltage schedule exemption (VAR-001/002)
- Added language to section 7.1.5 – Black Start units operators shall not permit their fuel inventory for Critical Black start CTs to fall below 10 hours – if it falls below this level, unit operators shall notify PJM and place the unit in Max Emergency

Revision 16 (10/01/2009):

- Section 4: Data Exchange and Metering Requirements: Updated Sections 4.2.2 and 4.2.3 to address metering requirements for distributed renewable generation.
- Section 6: Pre-Operational Requirements: Updated Sections 6.3.1 to address operations requirements for distributed renewable generation.
- Section 7: Generator Operations: Edits to voltage schedule details in Section 7.1.2.
- Section 8: Wind Farm Requirements: Minor edit in Section 8.1, updated Section 8.2.4 Generator Outage Reporting.
- Attachment D: PJM Unit Reactive Capability Curve Specification and Reporting Procedures: Updates in PJM Reactive Reserve Check (RRC) section.
- Attachment E: PJM Generator Reactive Capability Testing: Updates throughout ~~Testing Requirements for Units Larger than 70MW and Blackstart units~~ section; Replaced Lagging Form R and Leading Form R.



- Attachment F: Generator Reactive Testing Capability Procedures: Updates to Testing Procedure, Study Process Example, Communications and Coordination, Exit Strategy, and Results Reporting sections. Edits include identifying PJM Reliability Engineer as lead PJM coordinator for reactive testing process.

Revision 15 (04/01/2009):

- Section 4: Data Exchange and Metering Requirements: Updated Exhibits 4 and 5 to reflect the use of secure internet for small generators (100 MWs or less).
- Section 8: Wind Farm Requirements: Added new section describing Wind Farm Requirements
- Section 9: Generator Deactivations: Replaced PJM System Operations Generation Manager with PJM Power System Coordination Manager.
- Reactive Testing Attachments E & F: Renamed “Critical Steam” to “Near-term Steam” to avoid confusion with predefined Critical Infrastructure Facilities.
- Reactive Testing Attachments E & F: Added MOC requirement to review telemetered Generator MVAR accuracy with PJM Reliability Engineer in advance of commencing reactive test.
- Replaced “Control Area” with “Balancing Authority” to align with NERC definitions.

Revision 14 (12/17/2008):

Added existing Behind the Meter Generation Business Rules as Appendix A.

Revision 13 (5/23/2008)

Section 4: Data Exchange and Metering Requirements

- Updated Exhibits 4 and 5 to reflect the use of secure internet for small generators (50 MWs or less).

Section 5 and Section 7

- Modified to provide clarity regarding requirement to update generator reactive capability curves (D-Curves) following planned unit upgrades.

Section 7: Generator Operations

- Changes for new Bulk Electric System definition.



Revision 12 (12/03/2007)

- Provided clarification to Attachment E: PJM Generator Reactive Capability Testing and Attachment F: Generator Reactive Capability Testing Procedures, specifically, the ability to test outside May 1 – September 30th window on an exception basis, requirement to perform lagging test for 1 hour, requirement to report test results to Operations Planning Department within 10 days, and requirements to review accuracy of MVAR telemetry prior to beginning the test.

Formatted: PJM_Bulleted_Para_1 Char

Revision 11 (08/29/07)

Section 5: Participation in PJM Markets, Ancillary Services, Reactive Supply and Voltage Control from Generating Sources Service

- Added requirement for PJM to provide to the Generation Owner documentation of requirements for generator step-up transformer tap changes.

Section 7: Generator Operations, Critical Information and Reporting Requirements

- Added requirement for the Generator Operator to notify PJM of a status or capability change on any generator Reactive Power resource.

Attachment E: PJM Generator Reactive Capability Testing

- Modified Lagging Form R and Leading Form R to indicate that readings for Hour 2 are entered only if required.

Revision 10 (05/15/2007)

General Changes:

- Renamed references to Control Center Requirements and Dispatching Operations Manuals as Control Center and Data Exchange Requirements and Balancing Operations Manuals respectively.

Section 1: Black Start Replacement Process

- Changed Generation Department to Power System Coordination Department in section on Generator Commercial Naming Convention.

Section 8: Generator Deactivations

- Changed Generation Department to Power System Coordination Department in the text and in the process flow chart.

Section 9: Black Start Replacement Process - Process Flow Diagram

- Changed Generation Department to Power System Coordination Department.

Section 10: Generator Data Confidentiality Process

- Changed Generation Department to Power System Coordination Department.



Attachment D: PJM Generating Unit Reactive Capability Curve Specification and Reporting Procedures

- Changed Generation Department to Power System Coordination Department.

Attachment E: PJM Generator Reactive Capability Testing

- Clarified testing requirement as 20% of number of eligible assets per year.

Attachment F: Generator Reactive Capability Testing Procedures

- Changed Generation Department to Operations Planning Department.

Attachment K: Template Letter for a TO Seeking Generator Data

- Changed Generation Department to Power System Coordination Department.

Revision 09 (12/18/06)

Attachment E: PJM Generator Reactive Capability Testing

- Updated to reflect new exception criteria for PJM leading/lagging reactive tests.

Attachment F: Generator Reactive Capability Testing Procedures

- Updated to reflect new exception criteria for PJM leading/lagging reactive tests.

References to eMarket changed to eMKT throughout.

Definition of FTR changed to financial transmission rights (Section 5).

Introduction trimmed to eliminate redundant information.

Revision History permanently moved to the end of the manual.

Revision 08 (07/24/06)

Section 9: Black Start Replacement Process

- Updated to include new triggers for Black Start Replacement Process.
- Updated to reference the recently defined Minimum Critical Black Start Requirement.

Updated PJM List of Manuals (Exhibit 1).

Revision 07 (06/19/06)

Section 5: Participation in PJM Markets

- Change ~~unit~~ references to ~~resource~~ as they apply to Demand Side Response providing Ancillary Services.
- Change ~~Spinning~~ references to ~~Synchronized~~ as they apply to Demand Side Resources providing Ancillary Services.

Added Attachment F: Generator Reactive Capability Testing Procedures and relettered all following attachments.

Revision 06 (12/15/05)



Update to Attachment C on New PJM Customer Voice/All Call Communications Request Form to reflect most current version of the form.

Revision 05 (08/10/05)

Added new Section 9: Black Start Replacement Process.

Moved old Section 9: Generator Data Confidentiality Procedures to Section 10.

Formatted: PJM_Normal

Revision 04 (04/12/05)

Modified Section 8 to include revised Generation Deactivation process and procedures as approved by FERC on January 25, 2005.

Revision 03 (02/01/05)

Addition of new Section 9 on PJM Generator Data Confidentiality Procedures

Update to Attachment D on PJM Generating Unit Reactive Capability Curve Specification and Reporting Procedures to incorporate recent changes to the Reactive Reserve Check (RRC) Reporting process.

Addition of new Attachment E on PJM Generator Reactive Capability Testing. Current Attachments E and F have been renamed to Attachments F and G respectively.

Addition of new attachment H including the Generator Data Confidentiality Agreement.

Addition of new attachment I including the Generator – Data Release Matrix

Addition of new attachment J including a template letter for a Transmission Owner seeking generator data within its zone to be released by PJM

Update to Section 7 on Generator Operations to include new seasonal review of PJM generator reactive capabilities and reference to new Attachment E.

Revision 02 (03/10/04)

Added new Section 8 on Generator Deactivations.

Revision 01 (12/31/03)

Update format

Re-number exhibits

Revision 00 (04/04/03)



This revision is the initial release of the PJM Manual for **Generator Operational Requirements (M-14D)**. This manual is one among the four new manuals obtained from splitting the original PJM Manual for **Generator Interconnections and Operations (M-14)**.

The summary of revisions for this manual follows:

Added new Section 1 on Generator Markets & Operations.

Added new Section 2 on Responsibilities of Generation Owners.

Added new Section 3 on *Control Center Requirements* based on excerpts from PJM Manual M-01 on **Control Center and Data Exchange Requirements** (Section 2 & 3).

Added new Section 4 on *Data Exchange and Metering Requirements* based on excerpts from old PJM Manual M-14 on **Generation Interconnections and Operations** (Sections 2 & 5).

Added new Section 5 on *Participation in PJM Markets* based on excerpts from old PJM Manual M-14 on **Generation Interconnections and Operations** (Sections 3 & 4).

Added new Section 6 on *Pre-Operational Requirements* based on excerpts from old PJM Manual M-14 on **Generation Interconnections and Operations** (Sections 4 & 5).

Added new Section 7 on *Generator Operations* based on excerpts from old PJM Manual M-14 on **Generation Interconnections and Operations** (Sections 4 & 5), PJM Manual M-3 on **Transmission Operations** (Section 3), and PJM Manual M-13 on **Emergency Operations** (Section 5).