



Working to Perfect the Flow of Energy

PJM Manual 05

Power System Application Data

Revision: 05

Effective Date: December 12, 2005

Prepared by

System Planning Department

© PJM 2005



PJM Manual 05

Power System Application Data

Table of Contents

Table of Contents..... ii

Approval 1

Revision History..... 1

Introduction..... 1

 ABOUT PJM MANUALS 1

 ABOUT THIS MANUAL 2

 Intended Audience 2

 References 2

 USING THIS MANUAL 2

 What You Will Find In This Manual 2

Section 1: Power System Application Data 4

 APPLICATION PROGRAM & DATA INPUT FORMATS..... 4

 Bus Naming Convention 4

 Power Flow Data Guidelines..... 5

 Short Circuit Data Guidelines..... 8

 Dynamics Data Guidelines..... 11



Table of Exhibits

Exhibit 1: List of PJM Manuals 1
Exhibit 2: Static VAR Compensator Modeling 7
Exhibit 3: Remote Regulation 7
Exhibit 4: Three Winding Transformers..... 10
Exhibit 5: PJM Short-Circuit Modeling..... 11



Approval

Approval Date: 12/09/05
Effective Date: 12/12/05

Scott W. Gass, Manager
Transmission Planning Department

Revision History

Revision 05 (12/12/05)

This document has been reviewed per PJM procedures.
Updated Exhibit 1.

Revision 04 (02/22/05)

This document has been reviewed per PJM procedures.
Updated Exhibit 1 to include new PJM Manuals.

Revision 03 (04/23/04)

Renamed to **Power System Application Data**.

Removed Section 2: *Production Cost Data* and Section 3: *Regulatory & Reliability Assessment Data*.

Revision 02 (01/23/04)

Update Manual with new PJM formatting

Revision 01 (12/31/00)

Removed Attachment A: Definitions and Abbreviations. Attachment A is being developed into a PJM Manual for **Definitions and Abbreviations (M-35)**.

Revision 00 (04/29/98)

Section 02: Production Cost Data

- Changed PROMOD licensed by NewEnergy Associates from EDS.

Revision 00 (07/23/97)

This revision is the preliminary draft of the PJM Manual for **Data Management**.



Introduction

Welcome to the PJM Manual for **Power System Application Data**. In this Introduction, you will find the following information:

- What you can expect from the PJM Manuals in general (see “*About PJM Manuals*”).
- What you can expect from this PJM Manual (see “*About This Manual*”).
- How to use this manual (see “*Using This Manual*”).

About PJM Manuals

The PJM Manuals are the instructions, rules, procedures, and guidelines established by PJM for the operation, planning, and accounting requirements of the PJM RTO and the PJM Energy Market. Exhibit 1 lists the PJM Manuals.

Transmission	M01: Control Center Requirements	M02: Transmission Service Requests	M03: Transmission Operations
	M04: PJM OASIS Operation	M05: Power System Application Data	M06: Financial Transmission Rights
PJM Energy Market	M09: PJM eSchedules	M10: Pre-Scheduling Operations	M11: Scheduling Operations
	M12: Dispatching Operations	M13: Emergency Operations	M15: Cost Development Guidelines
	M36: System Restoration		
Generation and Transmission Interconnection	M14A: Introduction to the Generation and Transmission Interconnection Process	M14B: Generation and Transmission Interconnection Planning	M14C: Generation and Transmission Interconnection Facility Construction
	M14D: Generator Operational Requirements	M14E: Merchant Transmission Specific Requirements	M16: eDART Operations
Reserve	M17: Capacity Obligations	M19: Load Data Systems	M20: PJM Reserve Requirements
	M21: Rules and Procedures for Determination of Generating Capability	M22: Generator Resource Performance Indices	M23: eGADS User Manual
	M24: PJM eCapacity	M25b: eFuel 2.0 – User Manual	
Accounting & Billing	M27: Open Access Transmission Tariff Accounting	M28: Operating Agreement Accounting	M29: Billing
PJM	M33: Administrative Services for PJM Interconnection Agreement	M35: Definitions and Acronyms	

Exhibit 1: List of PJM Manuals

About This Manual

The PJM Manual for **Power System Application Data** provides guidelines for the power system data supplied by a Party to the PJM Transmission Owners Agreement that is required for regional planning studies.

Intended Audience

The intended audiences for the PJM Manual for **Power System Application Data** are:

- *Transmission Owner's Staff*
- *PJM Staff*

References

There are several references that provide both background and details. The PJM Manual for **Power System Application Data** does not replace any information in these reference documents. These documents are the primary source for specific requirements and implementation details.

- NERC Multiregional Modeling Working Group Procedural Manual
- NERC System Dynamics Database Working Group Procedural Manual
- NERC Power Flow and Dynamics Standards
- PTI PSS/E Operations Manual
- PTI PSS/E Applications Guide
- PJM Manual for Load Data Systems
- PJM Transmission Owners Agreement

Using This Manual

Because we believe that explaining to you concepts is just as important as presenting the procedures, we start each section with an overview. Then, we present details and procedures. This philosophy is reflected in the way we organize the material in this manual. The following paragraphs provide an orientation to the manual's structure.

What You Will Find In This Manual

- A table of contents
- An approval page that lists the required approvals and the revision history
- This introduction



- Sections containing the specific guidelines, requirements, or procedures including PJM actions and PJM Member actions
- Attachments that include additional supporting documents, forms, or tables in this PJM Manual



Section 1: Power System Application Data

Welcome to the PJM Manual for **Power System Application Data**. In this section you will find the following information:

- What the data requirements are for PJM power system analysis (see “*Application Program & Data Input Formats*”).

Application Program & Data Input Formats

PJM uses the application program “*Power System Simulator for Engineers (PSS/E)/Power Technologies, Inc.*” to perform power system analysis.

Power System Simulator for Engineers (PSS/E)/Power Technologies, Inc. - This analysis package contains programs for power flow, short circuit, and dynamic simulation of the power system.

Note that the solution convergence tolerances listed in this manual are set deliberately wide in order to ease the solution of interregional cases. Closer tolerances may be used at the discretion of the user.

It is encouraged that users of this manual forward recommendations for changes or additions to the PJM Transmission Planning Department. Thus, to ensure that this manual accurately reflects accepted practice and the latest requirements, it is subject to a periodic review by the PJM Transmission Planning Department.

The following several sections provide the power flow modeling guidelines for power system data submittal for the PJM regional planning process.

Bus Naming Convention

- PSS/E allows an eight space character string for bus naming, where an appropriate, recognizable, and unique name for the bus is entered. Note that base kV is considered part of bus name; two buses can have same name with different voltages and still be unique.
- PSS/E allows a four space character string for the base kV rating of the bus. It is preferred that this rating use a decimal for voltages less than 100 kV (i.e. 34.5, 13.8, 22.0, etc).
- Multiple generators on a single bus and plant units at different buses have the actual machine ID (where possible) at the end of their name block.
- For buses associated with short circuit data:
 1. The base kV of equivalent center point "dummy" buses for three winding transformer models are blank, since the voltage at this bus is meaningless and exists only for the purposes of solution.

2. Buses used to represent zero-sequence mutual line coupling use the appropriate base kV.

Power Flow Data Guidelines

- *Modeling Detail* - It is recommended that the level of modeling detail be high (all generators and their step-up transformers explicitly modeled, etc), and allow the user to determine what level of detail is required for a particular study.
- *Isolated Buses* - Isolated buses are not modeled. This is not a valid modeling technique for off-line generation. Isolated buses may, however, exist due to configuration changes that occur during particular studies.
- *Generator Modeling of Loads* - Pseudo generators are not used to "load net" (showing negative generation) to model other load embedded in power flow areas. It is recommended that a separate zone be used for modeling such loads to allow exclusion from system load calculations.
- *Zero Impedance Branches* - PSS/E provides for the treatment of bus ties, jumpers, and other low impedance branches as zero impedance lines. For a branch to be treated as a zero impedance line, its resistance must be zero and its magnitude of reactance must be less than or equal to the zero impedance line threshold tolerance (THRSHZ) set in the PSS/E program. Bus ties, jumpers, and low impedance branches that are modeled in detail are represented with $R=0.00000 + X=0.00001$ and $B=0.00000$. The zero impedance cutoff (THRSHZ) is set to 0.0001 in the PSS/E program.
- *Maximum Cut-off Impedance* - Where network representation has been equivalenced, a maximum cut-off impedance of 3.0 p.u. is used.
- *Tap-Changing-Under-Load (TCUL) Transformers* - It is recommended that TCUL transformer tap step size is no smaller than $STEP=0.00625$ p.u. (PSS/E default based on 32 tap positions) and that the controlling voltage band is at least 1.5 times the tap step size. A control band of two times the tap step size and a tap step size of at least 0.00625 is preferred to minimize iterations in interregional study cases.
- *Switchable Capacitors* - Switchable capacitors are modeled explicitly as switched shunts.
- *Phase-Shifter Models* - Phase-shifter sign conventions must be adhered to in all models. The MW tolerance for phase-shifting-under-load transformers are no less than ± 5 MW; i.e. a 10 MW dead-band. It is recommended that variable phase-shifters of less than 100 MVA capacity are either modeled as fixed phase-shift or not modeled at all.
- *Small Generators and Static VAR Devices (SVD)* - Small generators (less than 10 MVA) and small static VAR devices cannot adequately regulate

- transmission bus voltage (greater than 69 kV) with their limited reactive capability. Modeling these components as regulating only increases solution time. If a number of such devices are located at a bus, it is up to the discretion of the user to lump these units into a sufficiently large equivalent to speed solution. Small SVDs (<10 MVAR) should be modeled as fixed instead of regulating.
- Machine Impedance Data
 - 3. *Machine MVA Base* - The MVA base (MBASE) entered in the machine impedance data file is the machine MVA base, which is used for fault analysis and dynamic simulation.
 - 4. *Machine Impedance* - The machine impedance (ZSORCE = ZR, ZX) entered in the machine impedance data file is the complex unsaturated subtransient impedance entered in p.u. on the machine MVA base. This data is used for dynamic simulation.
 - 5. *Generator Step-Up (GSU) Transformers* - Although it is recommended that all GSU transformers be modeled explicitly, an explicitly modeled GSU is required for all machines greater than 100 MW capacity. A GSU not explicitly modeled has its p.u. impedance (XTRAN = RT, XT) on machine MVA base and p.u. off-nominal turns ratio (GENTAP) entered in the machine impedance data file.
 - *Out-of-Service Generator Modeling* - Out of service generators are modeled with a STATUS = 0, and never modeled as either disconnected buses (PSS/E type 4) or as a load bus (PSS/E type 1).
 - *Generator MW Limits* - For power flow analysis, the MW capability limits specified for generators (PMIN and PMAX) should represent realistic net plant output capability at the bus on which the generator is modeled. Note that the gross output of the machine is used for dynamic analysis. Also, PMAX is greater than or equal to PMIN, where PMIN is defined as the normal minimum MW output of the machine.
 - *Machine MVAR Limits* - The MVAR capability limits specified for machines (QMAX and QMIN) represents realistic net plant output capability at the bus on which the machine is modeled. Also, QMAX is greater than or equal to QMIN.
 - *Static VAR Compensator (SVC) Modeling* - An SVC is modeled as a PSS/E type 2 switched shunt. Note that if a switched shunt is attached to a generator-regulated bus, the generator regulates the bus voltage and the regulating ability of the SVC is ignored (output will not vary). The following examples illustrate continuous control modeling of SVCs in PSS/E (note that VSWHI = VSWLO for SVC modeling):

MVAR Range	N ₁	B ₁	N ₂	B ₂
-100 to 0	1	-100	0	0
0 to 50	1	50	0	0
-100 to 50	1	-100	1	50

Exhibit 2: Static VAR Compensator Modeling

- **Remote Regulation** - Remote regulation of a bus through another regulated bus (such as that shown in the figure below) is not permitted. Only load buses (PSS/E type 1 buses) may be remotely regulated. Users should ensure remote regulation is not specified more than 2 buses away from the regulating equipment.

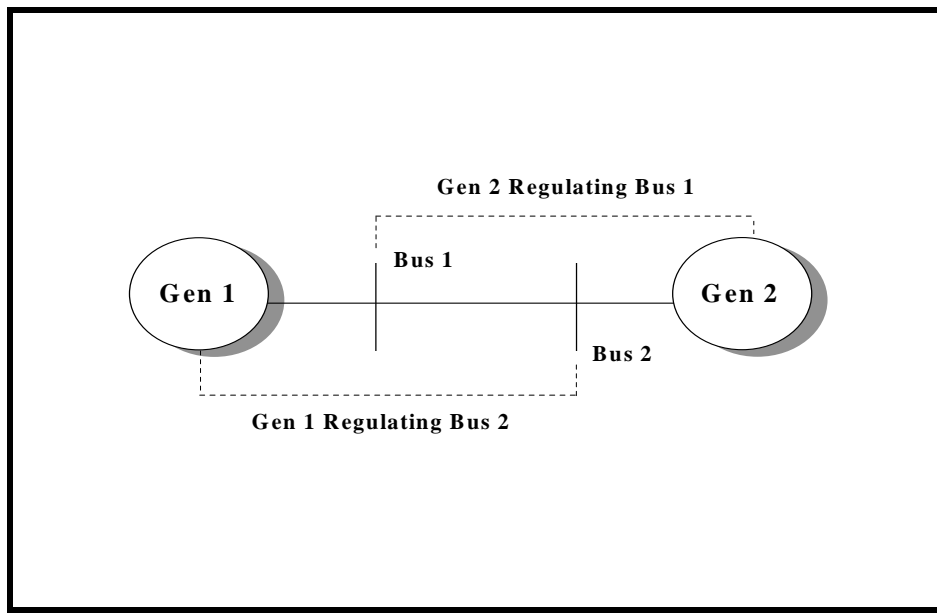

Exhibit 3: Remote Regulation

- **Conflicting Voltage Regulation** - Multiple regulating devices (generators, SVCs, switched shunts, TCULs, etc) controlling the bus voltage on a single bus must have their scheduled voltage and voltage control ranges coordinated. The PSS/E activity REGB tabulates those buses whose voltages are controlled by generation, switched shunts, or voltage controlling transformers.
- **Over/Under Voltage Regulation** - Regulation bus voltages are scheduled between 0.95 p.u. and 1.10 p.u.
- **System Base MVA** - The system base MVA for power flow analysis is 100 MVA.
- **Large Negative Reactances** - Large negative reactances (<-1.0 p.u.) for equivalent branches do not represent real devices and are not to be used. However, the possibility exists that 'T' representations of three winding

transformers in fault analysis models may indeed yield large negative reactances.

- *Branch Ratings* - A summer rating set and a winter rating set that encompass all branches in existence during a five year period must be submitted. For a particular season, each facility will have three different ratings that are designated as RATE A, RATE B and RATE C in PSS/E. RATE A will be used for pre-contingency analysis, RATE B will be used for post-contingency analysis and RATE C is typically not used.
 - ☞ Summer ratings are based on 95 degree F (35 C) ambient temperature and are generally used from April 15 to November 15.
 - ☞ Winter ratings are based on 50 degree F (10 C) ambient temperature and are generally used from November 15 to April 15.

NOTE: Refer to Section VI of the TSDS Technical Requirements for more detailed information on PJM equipment rating procedures.

Short Circuit Data Guidelines

Unbalanced fault analysis requires the modeling of full sequence component representation. The level of detail provided for each area is determined by the LSE (within the bus allocation) but for PJM system studies the sequence components of the main transmission system (69 kV and above) and all generation must be fully modeled.

Comparison With Power Flow Data

Modeling detail and component status information is dictated by the positive sequence (power flow) model, so the zero sequence and negative sequence networks required for unbalanced fault analysis must be topological subsets of the positive sequence network.

Negative and zero sequence data values are different from the corresponding positive sequence values. In setting up the negative and zero sequence networks, PSS/E assumes that:

- All transmission branches (lines and transformers) have the same impedance, charging, and line-connected shunt characteristics in the negative sequence as in the positive sequence.
- All transformers have phase shift in the negative sequence equal and opposite to that in the positive sequence.
- All zero sequence branches (i.e. transmission branches, line-connected shunts, and bus-connected shunts) are assumed to have infinite zero sequence impedance unless a different value is specifically entered.



- All constant MVA and constant current load specified in the positive sequence data are converted automatically to constant shunt admittance in the positive sequence network.
- All loads are automatically represented by the same shunt admittance in the negative sequence as in the positive sequence unless a different negative sequence shunt admittance is entered specifically.
- Loads are open circuits in the zero sequence unless represented specifically by entry of a value of shunt admittance.
- Lines considered zero impedance in the positive sequence are considered as zero impedance in the negative and zero sequence.

Short Circuit vs. Power Flow Topology

There are two primary areas where the power-flow and short circuit topology do not match:

- three-winding transformers
- mutual line coupling

Three Winding Transformers - In power flow models, three winding transformers are represented as any other but in short circuit analysis three winding transformers are expanded to a 'T' equivalent representation by the use of fictitious buses and equivalent circuits. Exhibit 4 illustrates the difference between the two models. Note that Z1 and Z2 represent positive, negative, and zero sequence impedances, while Z3 is the zero-sequence shunt impedance (which is inverted to provide the zero-sequence shunt admittance to ground at the dummy bus).

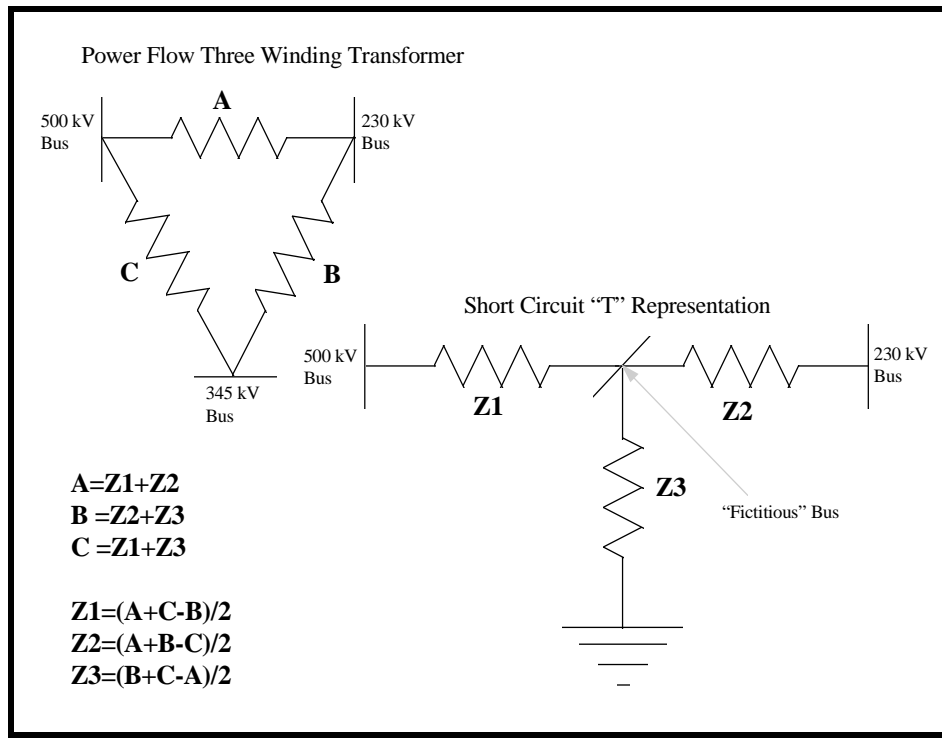

Exhibit 4: Three Winding Transformers

- **Mutual Line Coupling** - Short circuit analysis requires modeling the effect of mutual coupling of lines sharing a common right-of-way. Additional "fictitious" buses beyond that used for power flow analysis are required to model the zero-sequence mutual impedance of the lines. Note that although these buses are generally "fictitious" (i.e. not real or required for power flow analysis), they may represent existing substations.

Short Circuit Data

The short-circuit modeling of the PJM bulk power system requires the following information to be merged with power flow data. This data comprises the sequence data file (called by PSS/E activity RESQ), and is listed by equipment and the order of appearance in this file.

PJM/MAAC Short-Circuit Modeling	
Equipment	Order of Appearance in RESQ File
Generator	Positive Sequence Generator Impedance (ZPOS) Negative Sequence Generator Impedance (ZNEG) Zero Sequence Generator Impedance (ZZERO)
Shunt Load	Negative Sequence Shunt Load Data Zero Sequence Shunt Load Data
Branch/Transformer	Zero Sequence Branch Data Zero Sequence Mutual Impedance Data
Transformer	Transformer Grounding Code Data
Switched Shunt	Zero Sequence Switched Admittance Data
<p>Notes:</p> <p>(1) The generator sequence data is on machine MVA base (MBASE).</p> <p>(2) ZPOS and ZNEG default to ZSORCE if not entered</p> <p>(3) ZNEG defaults to ZPOS if not entered</p> <p>(4) For those machines at which the GSU is represented as part of the generator (i.e., XTRAN is non-zero), the zero sequence generator impedance (ZZERO) is not used and in fault analysis the GSU is assumed to be delta-wye.</p>	

Exhibit 5: PJM Short-Circuit Modeling

Dynamics Data Guidelines

Dynamic simulation is based on a power flow saved case that provides it with the required transmission network data, load data, and generator positive sequence model. However, the dynamics case has the following special data requirements:

Comparison With Power flow Data

A model must be selected from the dynamics library or must be user-defined for each piece of equipment (generator, exciter, excitation limiter, governor, current compensator, power system stabilizers, relays, etc) to be represented in the simulation. This data will comprise the dynamics data file which is called by the PSS/E activity DYRE.

The minimum modeling required for machines is a generator model. In general, each machine should also have one exciter, governor and power system stabilizer (if one exists) modeled.

It should be noted that all data entered in dynamic simulation tables is expressed with respect to the base MVA of the equipment that it represents.

The power flow data guidelines have specified that the GSU transformer will be explicitly modeled for all machines greater than 100 MW capacity. This will ensure that large steam units will have accurate generator models for dynamic simulation purposes, while eliminating such requirements for small machines (CTs, hydro, etc) where such accuracy is not required.



Dynamics Data

Dynamics modeling requires that the following machine impedance data, previously described in Power Flow Data Guidelines section of this manual, be merged with the power flow data:

- Actual Machine MVA base
- Complex Sub-Transient Reactance on Machine MVA Base
- If GSU modeled implicitly:
 - ☞ Complex GSU Impedance on Machine MVA Base
 - ☞ GSU off-nominal turns ratio