



COMMONWEALTH OF VIRGINIA

HOUSE OF DELEGATES  
RICHMOND

**RICHARD C. (RIP) SULLIVAN, JR.**

POST OFFICE BOX 994  
MCLEAN, VIRGINIA 22101

SIXTH DISTRICT

COMMITTEE ASSIGNMENTS:  
FINANCE (VICE CHAIR)  
COURTS OF JUSTICE  
LABOR AND COMMERCE  
RULES

October 31, 2025

The PJM Board of Managers  
c/o Mr. David E. Mills, Chair, PJM Board of Managers and  
Mr. Manu Asthana, President and CEO, PJM Interconnection  
PJM Interconnection, LLC  
2750 Monroe Boulevard  
Audubon, PA 19043

Re: Reduce Load from Data Centers by Reusing their Heat

Dear Chairman Mills, Mr. Asthana, and the Board of Managers,

As the Delegate representing Fairfax County—part of Virginia’s “data center alley”—I am deeply concerned with the impact that data center load is having and will continue to have on my constituents’ electricity prices and service reliability. Data centers are an essential component of the Virginia economy, but PJM must take every effort to ensure Virginia residents are not harmed by the proliferation of this industry. Data center load growth is one of the largest factors impacting electricity demand and costs in the PJM region. 63% of the increase in capacity prices in the 2025/26 auction can be attributed to data centers, translating to \$9.3 billion in infrastructure costs that will be passed on to ratepayers.<sup>1</sup> The 2025 forecast for PJM’s Dominion Zone estimated more than 20 GW of growth from data centers alone by 2037.<sup>2</sup>

While I applaud PJM for taking proactive steps to address data center load growth, I am concerned that one of the easiest solutions to make data centers more efficient and reduce data center demand — the reuse of heat produced at data center heat — has not been raised in the stakeholder conversations. Reuse of data centers’ heat reduces these facilities’ electricity demand, protecting ratepayers from surging prices while enabling regional economic development. It is essential that we leverage every possible tool to address skyrocketing load

---

<sup>1</sup> The Institute for Energy Efficiency and Financial Analysis, “[Projected data center growth spurs PJM capacity prices by factor of 10](#),” July 30, 2025.

<sup>2</sup> The Institute for Energy Efficiency and Financial Analysis, “[Projected data center growth spurs PJM capacity prices by factor of 10](#),” July 30, 2025.

growth, and many experts have identified energy efficiency and demand reductions as a key tool. PJM should prioritize reusing heat from data centers.

### **Heat Reuse is a Readily Available but Underutilized Technology**

Data centers essentially function as heat pumps, with more than 95% of the inputted electricity converted to heat. To prevent the servers from overheating, data centers consume large amounts of electricity—approximately 40% of their total electricity consumption—for cooling.<sup>3</sup>

Reusing data center heat reuse provides an alternative to this electricity-intensive process by transporting the waste heat to neighboring facilities that utilize it. This means the data center needs less electricity for cooling and can cut its demand by 10 to 30%.<sup>4</sup> This could translate to a 1200 to 3600 MW reduction in peak summer demand in the PJM region, greatly alleviating strain on the grid and protecting ratepayers from excess costs for new generation as more data centers come online.<sup>5</sup>

Data center heat reuse is widely deployed in Europe but remains an underutilized tool in the United States. The heat that data centers produce is low-temperature and is well-suited for a variety of applications, including in the pharmaceutical sector, the food and beverage sector, and industries that require hot water pre-heating like commercial laundries. The prevalence of these projects in Europe is largely due to policies that require, incentivize, or enable them, demonstrating the need for policy support in the United States.

### **PJM Should Use its Processes to Incentivize Heat Reuse to Reduce Overall Data Center Demand**

Speed to power is the most critical component of data center development, especially as wait times for grid connection lengthen in response to demand surges. PJM should leverage this desire for speed by turning grid connection into a carrot. PJM can prioritize energy efficient data center development by moving those with plans to reuse their heat up in the demand-side interconnection queue. This policy will also deliver the co-benefit of offering greater assurance of what data center demand will materialize, as it can be assumed that projects that secure an

---

<sup>3</sup> U.S. Department of Energy (U.S. DOE), “[DOE Announces \\$40 Million for More Efficient Cooling for Data Centers](#),” May 9, 2023.

<sup>4</sup> U.S. DOE, “[DOE Announces \\$40 Million for More Efficient Cooling for Data Centers](#),” May 9, 2023.

<sup>5</sup> Based on the estimated 12,000 MW increase in summer peak power demand from current and planned peak power. Monitoring Analytics, “[Analysis of the 2026/2027 Base Residual Auction Part A](#),” October 1, 2025.

offtaker for their heat are further in the development process. As many experts are concerned that PJM's forecasts are inflated, this additional qualification is greatly beneficial.<sup>6</sup>

The PJM Board should integrate data center heat reuse into its interconnection and planning processes. By prioritizing projects that demonstrate a commitment to energy efficiency and heat utilization, PJM can simultaneously reduce electricity demand, shield ratepayers from escalating costs, and enable economic development in the region. The challenges of rapid load growth require equally innovative solutions, and incentivizing data center heat reuse represents a pragmatic and cost-effective approach to ensuring system reliability and affordability for all PJM stakeholders.

I welcome the opportunity to discuss reuse of data center heat further with the PJM Board of Managers and look forward to working with you to address load growth while balancing economic development and affordability for ratepayers.

Best,



Richard C. (Rip) Sullivan, Jr.

---

<sup>6</sup> The Institute for Energy Efficiency and Financial Analysis notes that “there are strong reasons to believe PJM’s 20-year forecasts for data center growth are inflated” in [“Projected data center growth spurs PJM capacity prices by factor of 10,”](#) July 30, 2025.



# **Data Center Heat Reuse: The Opportunity for States**

**David Gardiner and Associates**

David Gardiner, Anna Dixon, Emily Kent, and Hannah Schuster

September 2025



## TABLE OF CONTENTS

<b>Executive Summary</b> .....	<b>1</b>
<b>The Context: Data Centers are Driving Electricity Load Growth</b> .....	<b>1</b>
<b>The Opportunity: Data Center Heat Reuse</b> .....	<b>3</b>
Heating Applications.....	5
Cooling Applications .....	7
Geographic Scope.....	8
<b>The Challenge: Barriers to Deployment</b> .....	<b>9</b>
<b>The Call: State Policies</b> .....	<b>10</b>
Solutions to Barrier 1: Enabling Policies.....	11
Solutions to Barrier 2: Financial Incentives .....	12
Solutions to Barrier 3: Standards.....	13
<b>Conclusion</b> .....	<b>13</b>
<b>Appendix 1 — Further Explanation of Data Center Cooling Methods</b> .....	<b>14</b>
<b>Appendix 2 — Policy Options for Data Center Heat Reuse</b> .....	<b>14</b>
Enabling Policies .....	14
Financial Incentives .....	14
Standards .....	15
<b>Appendix 3 — Existing Projects in North America</b> .....	<b>15</b>
Projects in the United States .....	15
Projects in Canada .....	16



## EXECUTIVE SUMMARY

To help address rising electricity demand, state governments should adopt policies that drive the reuse of heat produced at data centers to heat and cool nearby buildings and factories. Data centers use as much as 40% of their power needs to keep them cool enough to operate, which means that reusing their waste heat will lower power demand from data centers by 10 to 30%. By sending its heat to a nearby building or factory, a data center turns that heat from an unwanted byproduct of its operations into a productive resource, while reducing the need for new power generation. This also can drastically reduce data centers' water consumption, as the heat is reused in another application, rather than expelled through water evaporation.

Reusing heat from data centers will lower costs for electricity customers. By fully deploying data center heat reuse through 2029, states could avoid constructing 54 new conventional 500 megawatt power plants, saving customers \$22.1 billion in construction costs.

In essence, the data center would operate like a heat pump, recovering its heat—which varies between 25 to 35°C (77 to 95°F) or 50 to 60°C (122 to 140°F) depending on the cooling system—to reduce power and water demand and costs for data centers and heating or cooling costs for end users. Data center heat reuse will reduce the strain on the electric grid and cut costs and emissions for both the data center and the heat user. The best opportunities to reuse data center heat include in food, beverage, and pharmaceutical factories and for cooling and hot water heating of commercial and government buildings.

In the United States, heat from data centers is an untapped resource; however, European countries are seizing this opportunity to lower costs and deliver other benefits to data centers, factories, buildings, and local communities. A data center provided the heat for the swimming pools at the 2024 Olympics in Paris, for example.

The U.S. has been slow to seize this opportunity because three key barriers hinder data center heat reuse: difficulty pairing data centers with heat end-users, high capital costs and project risks, and a lack of supportive policy frameworks. Governments should adopt policies to overcome these challenges. Using specific examples which other governments have adopted, this report outlines a diverse policy menu that state governments can use, including:

- Enabling policies, such as funding for demonstration projects, thermal network development, and local zoning coordination.
- Financial incentives, such as tax credits and grants.
- Requirements, such as efficiency standards and emissions fees.

These policies can catalyze collaboration, attract investment, and scale the adoption of this mutually beneficial energy solution for data centers, heat and cooling users, power companies, electric utility regulators, and customers. This report focuses on the untapped potential of heat reuse from data centers, including the context, barriers, and recommended policies to realize the full potential of the opportunity.

## THE CONTEXT: DATA CENTERS ARE DRIVING ELECTRICITY LOAD GROWTH

Electricity demand in the United States (U.S.) increased slowly from 2009 to 2023, but it is projected to experience rapid growth in the coming decades. A 2025 study from ICF projects U.S. electricity demand



could grow 25% by 2030 and 78% by 2050 compared to 2023 demand.<sup>1</sup> The convergence of electrification of new sectors, revitalization of American manufacturing, and proliferation of new data centers is expected to significantly increase domestic electricity demand. This paper will focus on the only one of these factors: data centers.

New data centers are a major driver of expected electrical growth. In 2023, data centers accounted for 4.4% of total U.S. electricity consumption; by 2028, the U.S. Department of Energy (DOE) projects that this will grow to 6.7 to 12% of electricity demand.<sup>2</sup> Industry projections indicate that data center power demand will grow between 65 and 90 gigawatts (GW) by 2029—an amount equal to 130 to 180 new conventional natural gas plants.<sup>3</sup> Reuse of data center heat, which can lower data centers' power demand by 10 to 30%, could reduce new power demand by as much as 27 GW, avoiding the construction of as many as 54 new conventional 500 megawatt (MW) power plants.<sup>4</sup> This translates to an avoided \$22.1 billion in total construction costs.<sup>5</sup>

While U.S. data centers' exact electricity demand in the coming decade remains unknown, one thing is clear: data centers require massive amounts of electricity, especially to meet the needs of artificial intelligence (AI). New chips required to meet AI's vast processing needs will use more electricity and produce more heat, thus increasing power demand for cooling.<sup>6</sup> Hyperscalers—massive data centers that support cloud service providers like Google, Amazon Web Services, and Microsoft—are planning to build data centers that require one GW of electricity capacity. If a one GW data center were to operate at maximum capacity all year, it would consume 8,760 GWh per year—significantly more than the 5,126 GWh of electricity consumed by the entire county of San Francisco in 2024..<sup>7</sup>

Data centers' electricity demand is driven by two main operations: computing and cooling. The servers housed in data centers have a large electricity demand to perform their operations; everything from sending an email to asking ChatGPT a question to reading this report online requires computing that takes place in a server housed in a data center. While performing these functions, nearly 100% of the energy the servers use is turned into heat, requiring extensive cooling to prevent these servers from overheating.<sup>8</sup>

Cooling, even with the most efficient processes, represents a significant portion of data centers' electricity demand. DOE estimates that up to 40% of a data center's overall energy usage is attributed to cooling.<sup>9</sup>

There are four types of cooling utilized by data centers, listed in order of highest to lowest electricity needs: mechanical cooling, high efficiency mechanical cooling, adiabatic cooling (the most common

---

<sup>1</sup> ICF, "[Rising Current: America's growing electricity demand](#)," 2025.

<sup>2</sup> U.S. DOE, "[DOE Releases New Report Evaluating Increase in Electricity Demand from Data Centers](#)," Dec. 20, 2024.

<sup>3</sup> Grid Strategies, "[Strategic Industries Surging: Driving US Power Demand](#)," pg. 2, Dec. 2024.

<sup>4</sup> U.S. DOE, "[DOE Announces \\$40 Million for More Efficient Cooling for Data Centers](#)," May 9, 2023.

<sup>5</sup> This calculation is based on the U.S. EIA's cost of construction of a natural gas-fired electricity generators at \$820 per kilowatt hour. U.S. EIA, "[U.S construction costs rose slightly for solar and wind, dropped for natural gas in 2022](#)," Oct. 22, 2024.

<sup>6</sup> Christopher Tozzi, "[Assessing AI's Impact on Data Center Heating and Cooling Needs](#)," Nov. 4, 2024.

<sup>7</sup> California Energy Commission, "[Electricity Consumption Dashboard](#)," last accessed Sept. 8, 2025.

<sup>8</sup> Open Compute Project, "[Data Centers Heat Reuse 101](#)," 2023.

<sup>9</sup> U.S. DOE, "[DOE Announces \\$40 Million for More Efficient Cooling for Data Centers](#)," May 9, 2023.



method in the U.S.), and free air cooling (only applicable in cold climates).<sup>10</sup> Refer to Appendix 1 for further information on data center cooling methods.

## THE OPPORTUNITY: DATA CENTER HEAT REUSE

Reusing heat from data centers represents an opportunity for states to lower the power and water demand of data centers and for industrial and commercial building end users to cut their costs and emissions. Prime offtakers for data center heat include industrial manufacturers, such as the food and beverage and pharmaceutical sectors, and commercial buildings for heating and cooling.

Data centers produce low-temperature heat, but the exact temperature range depends on the cooling method. Air-cooled data centers typically generate heat between 25 and 35°C (77 to 95°F), liquid-cooled data centers' heat is between 50 and 60°C (122 to 140°F), and two-phase refrigerant-cooled systems' heat is up to 90°C (194°F).<sup>11</sup>

Figure 1: Data Center Heat Reuse

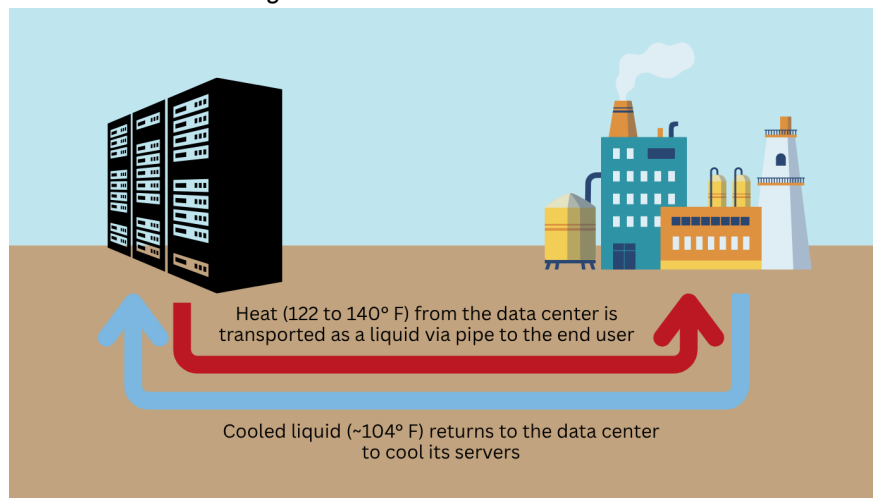

At new data centers, heat reuse can reduce power demand by 10 to 30%. Except for free air-cooled data centers, each data center cooling method requires a liquid—typically water, glycol mixtures, or synthetic oils.<sup>12</sup> This further enables data center heat to be reused in other applications as the liquid can serve as an efficient heat transfer medium to move the heat to factories and buildings.

The growing use of two new cooling methods—liquid cooling and immersion cooling—will allow data centers to capture higher temperature heat. Liquid cooling uses a range of technologies but involves transferring heat to a liquid to dispel it. The distance between the heat source—the server—and the liquid differs and affects the efficiency of the cooling method. Immersion cooling is a type of liquid cooling in which the servers are submerged a non-conducting fluid.<sup>13</sup> These methods are more efficient than air-

<sup>10</sup> Microsoft, “[Modern datacenter cooling](#),” 2023.

<sup>11</sup> Wang, Pengtao et. al, “[District heating utilizing waste heat of a data center: High-temperature heat pumps](#),” Jul. 15, 2024.

<sup>12</sup> Flexential, “[Liquid cooling in data centers: A deep dive](#),” Feb. 29, 2024.

<sup>13</sup> Center for Expertise for Data Center Energy, “[Liquid Cooling](#),” Lawrence Berkeley Lab, 2025.



cooled systems at recovering heat from data centers and are likely to become more prominent. Liquid cooling, for example, is currently used in approximately 10% of data centers, but is expected to become a more prevalent cooling method.<sup>14</sup> A data center using high temperature immersion cooling can extract heat at 70°C (158°F).<sup>15</sup> New policies to drive heat reuse at data centers could also accelerate use of liquid and immersion cooling.

Data center heat reuse can also drastically reduce the high water consumption of data centers, which has raised concerns from many groups. One 15 MW data center uses as much water as three average-sized hospitals or more than two 18-hole golf courses. By 2027, global AI demand could be responsible for 1.1 to 1.7 trillion gallons of annual water withdrawal.<sup>16</sup> This high water demand is due to some cooling methods that data centers currently use, wherein water is used to absorb heat from servers, the warmed water is then sent to an evaporation tower, and the heat is rejected when the warmed water evaporates. This requires a continuous supply of water for cooling, whereas heat reuse allows for continuous circulation of the water or other liquids, as the heat is expelled to an application rather than through evaporation.

**The reuse of data center heat in other applications can reduce emissions for both the data center and the heat end user, helping to achieve these companies' goals:**

- First, the data center reduces its electricity consumption by reducing its cooling needs—thereby reducing its emissions and putting less strain on the regional electric grid.
- Second, the heat offtaker replaces the heat required for its operations with zero- or low-carbon heat, as data center heat is a byproduct of another operation.<sup>17</sup> It is important to note that in terms of emissions accounting, the heat end-user claims the emissions reductions from the heat reuse, as they are mitigating fuel combustion—and therefore carbon emissions—with the data center heat.<sup>18</sup>

Heat reuse also presents an economic opportunity for data centers, as they can monetize their heat by selling it to end users for the emissions avoidance and reduce their electricity bill. If they do not want to be in the business of selling heat, data centers can donate their heat to buildings, swimming pools, or other community-focused applications, increasing community buy-in and support for data center infrastructure development.

Data centers require a continuous supply of electricity as they operate 24/7; the average data center's uptime is 99.8% annually.<sup>19</sup> This poses a challenge to data center deployment, as grid electricity is becoming increasingly unreliable due to increased load and climate change-heightened severe weather events. However, this also makes data centers prime heat providers, as they offer a reliable source of heating and cooling.

---

<sup>14</sup> Data Center Group, "[Waste heat recovery from data centers](#)," Aug. 3, 2021.

<sup>15</sup> Open Compute Project, "[High-Temperature Immersion Cooling: Pathway to Sustainability](#)," Sept. 2024.

<sup>16</sup> World Economic Forum, "[Why circular water solutions are key to sustainable data centers](#)," Nov. 7, 2024.

<sup>17</sup> Open Compute Project, "[Data Center Heat Reuse 101](#)," pg. 7, 2023.

<sup>18</sup> This is supported by the World Resources Institute's [Greenhouse Gas Protocol Guidance for Scope 2 emissions](#).

<sup>19</sup> Open Compute Project, "[Data Center Heat Reuse 101](#)," pg. 7, 2023.



Data center heat reuse is a nascent industry. There are dozens of deployments globally, but only a handful of U.S. projects. In New York, Con Edison is piloting a thermal energy network that will transport data center heat one block to a central heat pump plant that services a New York City Housing Authority community in the Chelsea neighborhood of Manhattan.<sup>20</sup> For a more comprehensive list of projects, see Appendix 3.

There are a variety of data center heat reuse projects being planned and deployed in Europe—largely due to regulatory factors discussed later in this paper. One such project was for the 2024 Summer Olympics in Paris. An aquatic center in Paris, which hosted a training pool for the Olympics, is heated by waste heat from an Equinix data center.<sup>21</sup>



*Amazon’s headquarters in Seattle reuses heat from a neighboring data center at the Westin Building Exchange (left) for space heating. The data center produces the equivalent of 11 MW per day of heat, 5 MW of which is used in Amazon’s district heating system, servicing two 37-story buildings (one photographed on the right) and one 16-story building, with the ability to continue serving the campus as it builds out. The project avoids 80 million kilowatt hours of electricity use over 25 years.<sup>22</sup>*

---

## HEATING APPLICATIONS

Rather than lowering the heat with energy-intensive cooling operations, data centers can capture heat and send it for reuse in other applications in nearby factories and buildings that require large amounts of low-temperature heat. The heat can be transferred to these facilities, where it is consumed, and then the cooled water (the precise temperature of which varies based on the temperature of the heat exiting the data center and the amount of heat extracted by the offtaker) can return to the data center, reducing electricity consumption for cooling.<sup>23</sup>

---

<sup>20</sup> ConEdison, “[Thermal Energy Networks](#),” last accessed Apr. 2025.

<sup>21</sup> Equinix, “[The internet is sustainably heating Paris and the Olympic training pool](#),” last accessed Apr. 2025.

<sup>22</sup> International District Energy Association, “[District Energy: Fourth Quarter](#),” pg. 8-10, 2017.

<sup>23</sup> ASHRAE, “[Emergence and Expansion of Liquid Cooling in Mainstream Data Centers](#),” 2021.



Some specific applications for using data center heat to produce steam and hot water include:

- **Food and beverage pasteurization.** Both packaged and nonpackaged food and beverages—such as milk, almonds, juices, beer, cheese, and ready meals—require pasteurization. This is a process that involves applying mild heat treatment, usually under 100°C, to extend shelf life and kill any harmful bacteria or pathogens. Data center heat at 75°C would be a suitable temperature for this application. The hot water volume that is recovered from most data centers is greater than a pasteurization facility's requirements; a 1 to 5 MW liquid-cooled data center would produce a volume of sufficiently heated hot water that matches a pasteurization facility's requirements.
- **Other food and beverage applications.** Beyond pasteurization, there are many applications for low-temperature heat in the food and beverage sector, including pre-cook processes, batch heating, and facility cleaning. These processes vary widely and utilize process hot water at 60° to 75°C. Large food and beverage facilities with 24/7 operations and scheduled cleaning operations could use a significant portion of a data center's heat output, but hot water storage would be needed to facilitate the peak cleaning hot water volume requirement. Hot water volumes from a 1 MW and up to a 10 MW data center are sufficient for large, centralized fish, meat, and chicken processing as well as large breweries, high volume greenhouses, and vegetable packing.
- **General water pre-heating.** Water pre-heating is used across the industrial, residential, and commercial sectors for applications that require large quantities of hot water, like laundry, cleaning dishwashers, pools, and domestic hot water generation. Pre-heating water raises the temperature somewhat, requiring less energy later to heat the water to its ultimate required temperature. Data center heat can be used to perform this process. The hot water requirements for space heating, domestic hot water generation, laundry, cleaning dishwashers, and pools are generally greater than 75°C, but hot water from liquid-cooled data centers can be used to pre-heat some of these applications' hot water needs. Other use cases—including in the hospitality industry—require lower temperature water and can use data center heat to meet these needs. In the hotel industry, for example, water heating is the largest single end-use for energy, making up almost a third of total energy use.
- **Pharmaceutical heating.** Pharmaceutical facilities use large volumes of hot water and steam for laboratories and clean rooms, which require 24/7 application of thermal energy. Most pharmaceutical thermal requirements are 75°C for heating, dehumidification and process heat, which can be achieved with data center heat. A 1 or 5 MW liquid-cooled data center would provide heat sufficient for these pharmaceutical applications. In 2016, the U.S. represented 30 to 40% of the worldwide pharmaceutical market, signifying an ample opportunity for data center heat reuse in this sector domestically.<sup>24</sup>

---

<sup>24</sup> ACS Chemical Neuroscience, "[New 2016 Data and Statistics for Global Pharmaceutical Products and Projections through 2017](#)," Aug. 16, 2017.



## COOLING APPLICATIONS

Data center heat may be an option to meet cooling needs, particularly with higher temperature waste heat. While vapor compression chillers use electricity to produce cooling, thermal-driven chillers—either absorption or adsorption designs—produce cooling from thermal energy. The thermal energy can be provided by indirect sources, such as hot water, steam, combustion exhaust, or, as in this case, waste heat.<sup>25</sup>

Figure 2: Absorption Chilling<sup>26</sup>

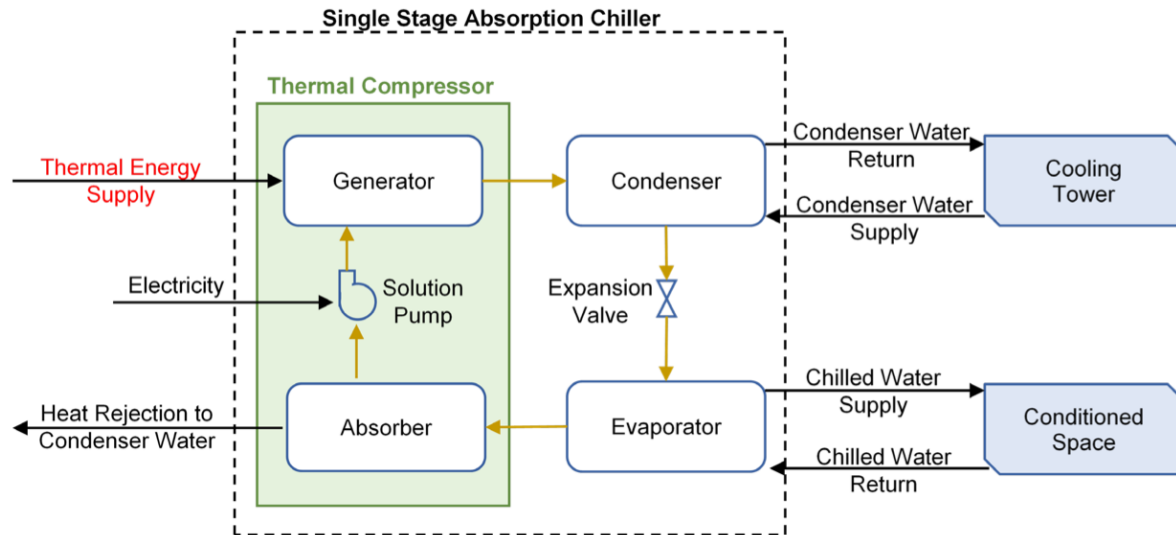

Absorption and adsorption chillers require different temperatures from their thermal source. Existing adsorption chillers can use heat as low as 125°F to produce cooling, and chillers that can utilize even lower temperature heat are being developed. Absorption chillers require heat that is above 160°F.<sup>27</sup> Process or space cooling using a low-temperature absorber will typically create a temperature differential of 12°C so that the 75°C supply is reduced to 63°C.<sup>28</sup> Thermal-driven chillers using data center heat can produce chilled water at 20°C (68°F).<sup>29</sup> The ability to use data center heat for cooling expands the sectors and climates in which this solution can be deployed.

The temperature range of data center heat makes it a suitable partner with specific sectors and applications that rely on large amounts of low-temperature heat and cooling, including for:<sup>30</sup>

- **Food and beverage applications.** There are many processes in the food and beverage sector that utilize cool water, including batch cooling. An absorption chiller driven by 75°C water could provide cooling. Large food and beverage facilities with 24/7 operations could use a significant

<sup>25</sup> U.S. DOE, “[Absorption Chillers for CHP Systems](#),” May 2017.

<sup>26</sup> U.S. DOE, “[Absorption Chillers for CHP Systems](#),” May 2017.

<sup>27</sup> Based on consultation with an expert.

<sup>28</sup> Based on previous, unpublished analysis by David Gardiner and Associates.

<sup>29</sup> Advanced Liquid Cooling Technologies, “[Heat Reuse in Data Center](#),” 2024.

<sup>30</sup> David Gardiner and Associates, “[Data Center Heat Reuse — Benefits and Applications](#),” Apr. 4, 2024.



portion of a data center’s heat output. Hot water volumes from a 1 MW and up to a 10 MW data center are sufficient for process cooling, which is additive to the heating load of the offtake facility.

- **Commercial space cooling and refrigeration.** Commercial buildings encompass a range of facilities that require large amounts of electricity (approximately 36% of U.S. electricity consumption in 2024 was for commercial buildings), primarily driven by cooling.<sup>31</sup> This cooling load—particularly for offices in large commercial buildings, healthcare, and retail—can be met with hot water-driven absorption. This can utilize data center heat, especially in the southern U.S. for long-season cooling. 1 to 10 MW liquid-cooled data centers are compatible with the cooling needs of large commercial cooling applications such as laboratories, office buildings, large enclosed retail, and large conditioned warehouses.

## GEOGRAPHIC SCOPE

As shown in Figures 3 and 4, the sectors that can use data center heat for either heating or cooling applications are prominent throughout the continental U.S., allowing for data center heat reuse to be deployed nationwide.

Figure 3: Pharmaceutical and Medicine Manufacturing in the U.S.<sup>32</sup>

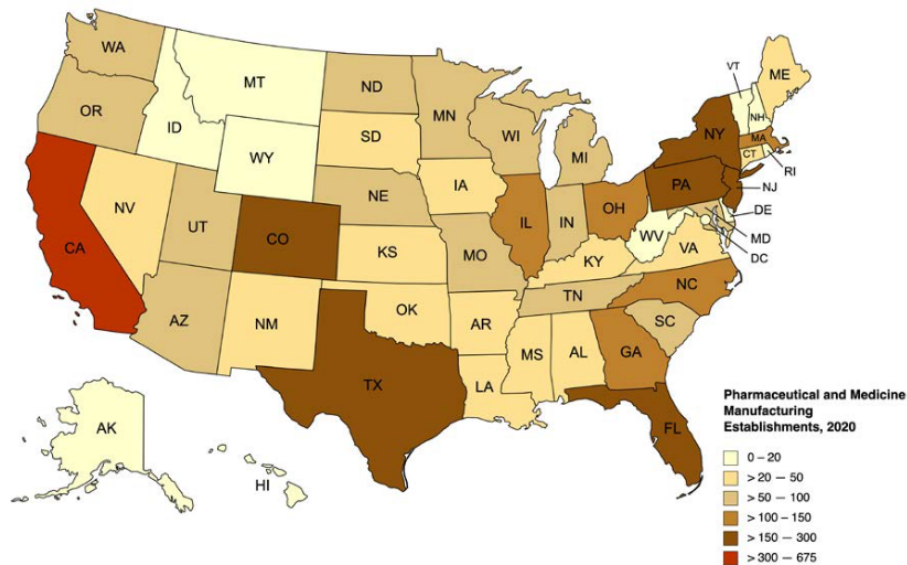

<sup>31</sup> Based on the Energy Information Administration’s February 2025 of the “[Electric Power Monthly](#)”.

<sup>32</sup> U.S. Census Bureau, “[County Business Patterns: 2020](#),” Apr. 2022.



Figure 4: Food and Beverage Manufacturing in the U.S.<sup>33</sup>

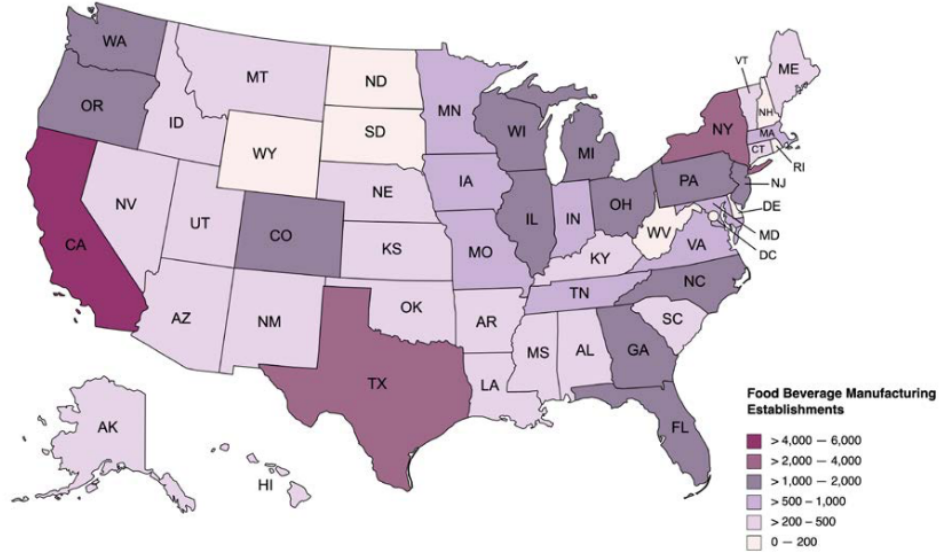

## THE CHALLENGE: BARRIERS TO DEPLOYMENT

While an increasing number of data center heat reuse projects are being deployed internationally, key challenges remain in the U.S., barring widespread adoption of this climate solution. Three main barriers are:

1. It is difficult for data centers to locate appropriate heat offtakers.
2. Data center heat reuse projects face project development risks and costs typical for new energy providers.
3. An uneven playing field makes it difficult to be the first mover.

Within these high-level barriers, there are more specific challenges, such as:

- **Lack of knowledge and awareness of the opportunity.** Many data center operators and potential heat end-users lack awareness of the technical solutions available for heat recovery, transfer, and reuse. Heat users do not typically view data centers as heat sources, and data centers do not see themselves as energy providers. This gap in knowledge often reduces the potential for partnerships between compatible sectors, limiting opportunities for dialogue and the exploration of viable heat recovery applications.
- **Lack of proximity and connections between data centers and heat users.** Transporting heat can require expensive infrastructure buildout and can be technically challenging, making it beneficial to site data centers near facilities that could utilize their excess heat. However, data centers and potential heat users frequently struggle to connect with one another, simply because they do not know of each other. Fostering new relationships between these entities would allow data centers to figure out what potential heat offtakers are already located near their facilities and

<sup>33</sup> U.S. Census Bureau, "[County Business Patterns: 2020](#)," Apr. 2022.



consider opportunities to build new facilities near potential offtakers. Additionally, data center planning and zoning is often done in isolation from the infrastructure development of industries that could benefit from recovered heat.

- **Supply and demand discrepancies.** Local climate conditions can create seasonal fluctuations in heating needs—particularly in colder regions—while other areas may have minimal demand. Agricultural operations like greenhouses, fish farms, or biomass dehydration facilities may require heat at varying intensities throughout the year. In some cases, geographic and distance-related constraints make it difficult to align recovered heat supply with suitable demand. These factors make it challenging to consistently utilize 100% of the recovered heat.
- **Data center heat reuse projects face project development risks and costs.** As an emerging industry, data center heat reuse faces both technological and financial hurdles. End users often lack familiarity with the systems and expect reliable performance. The complexity of linking data centers to heat consumers can introduce significant project risks. Even in the most straightforward scenarios, the financial burden can be substantial due to the costs associated with installing and maintaining infrastructure such as underground piping, pumping stations, heat pumps, and control systems.
- **Lack of national and sub-national policy.** In the U.S., few policies exist at any level—municipal, state, nor national—to enable, incentivize, or require data center heat reuse, despite its potential to significantly reduce load growth from data centers and greenhouse gas emissions. Governments are only just starting to become aware of data center heat reuse as a viable mechanism to reduce greenhouse gas emissions, lower costs, and enhance national security. Policies that incentivize heat reuse can reduce the technology and financial risks of these projects and help achieve states’ decarbonization goals

## THE CALL: STATE POLICIES

State-level policies can play a major role in developing data center heat reuse projects. States with large populations and significant amounts of industrial development (i.e., California, Texas, and New York) have many potential opportunities across the prime applications for data center heat previously discussed, but every state can adopt policies to enable, incentivize, or regulate data center heat reuse to reduce strain on their regional electric grid and lower costs and emissions.<sup>34</sup> The table below outlines enacted or proposed policies, followed by more detail on and examples of each, and Appendix 2 provides a full list of the policies referenced.

There are also innovative new policy ideas that have been raised, though they are not the focus of this paper as to our knowledge these have not yet been proposed or enacted. These potential future policies include use of utility policy (e.g., order of requests in interconnection queues, tariffs, new rate classes for data centers, etc.) to incentivize data center heat reuse and allowing heat offtakers to get credit for their waste heat usage in carbon accounting mechanisms.

---

<sup>34</sup> The primary states identified were based on previous, unpublished analysis by David Gardiner & Associates.



**Summary Table: Policy Solutions to Key Barriers**

Barrier	Policy Recommendation
<b>Barrier 1: It is difficult for data centers to locate heat offtakers.</b>	Support projects that demonstrate the technical feasibility of data center heat reuse.
	Establish matching platforms for data centers and heat end users.
	Develop district thermal energy networks to provide heating and cooling to neighborhoods and campuses as an alternative to on-site thermal generation.
	Leverage local and regional planning to collocate data centers and heat offtakers.
<b>Barrier 2: Data center heat reuse projects face project development risks and higher costs for new energy providers.</b>	Offer tax credits for the reuse of data center heat.
	Provide grants or low-interest loans for data center heat reuse.
<b>Barrier 3: An uneven playing field makes it difficult to be the first mover.</b>	Establish energy efficiency standards for data centers that allow data center heat reuse to meet the requirements.
	Require plans for heat reuse in permitting of new data centers.
	Establish a fee for a data center’s greenhouse gas emissions from electricity consumption.

## SOLUTIONS TO BARRIER 1: ENABLING POLICIES

- Demonstration projects of data center heat reuse.** The National Renewable Energy Laboratory (NREL) operates a data center heat reuse demonstration project. The data center uses warm-water liquid cooling, then captures and reuses the heat as the primary heating source throughout proximate office and laboratory space.<sup>35</sup> Demonstration projects like this help prove technical viability of solutions. In this case, NREL—a government entity itself—is running the project, though government agencies can also provide funding for demonstration projects in the private sector.
- Establish matching platforms for data centers and heat end users.** Matching platforms help connect data centers with heat offtakers. These can be designed to either promote direct sales between data centers and heat end users or can utilize energy service companies (ESCO) as an intermediary, which requires less government involvement compared to public-private partnerships or utility programs. The European Union (EU) currently operates the Heat and Cold

<sup>35</sup> NREL, “[High-Performance Computing Data Center](#),” last acc. Apr. 2025.



Matching Platform, which allows industries and facilities with surplus heating and cooling to identify those who need it.<sup>36</sup> Virginia introduced legislation in 2025 that would establish an interactive map of data centers and potential heat users, but the legislation failed.<sup>37</sup>

- **Develop district thermal energy networks.** Thermal energy networks, which distribute thermal energy from a central source to multiple buildings, are a well-established model for utilizing surplus or renewable heat. States can enable buildout of this infrastructure through legislative and utility action. In the U.S., New York’s Utility Thermal Energy Network and Jobs Act directed utilities to pilot these systems as part of a broader building decarbonization effort.<sup>38</sup> One of the pilot projects uses heat from a data center for heating in residential buildings. Seven other states in addition to New York—California, Colorado, Massachusetts, Maryland, Minnesota, Washington, and Vermont—have passed similar legislation to support the development of utility-scale thermal energy networks.<sup>39</sup>
- **Leverage state, local, and regional planning to collocate data centers and heat offtakers.** State, local, and regional planners can enable data center heat reuse by including data centers and nearby heat users in zoning considerations—for example, planners can zone data centers near industrial parks or around an incumbent thermal energy network—and ensure pipeline heat connections when planning infrastructure.

---

## SOLUTIONS TO BARRIER 2: FINANCIAL INCENTIVES

- **Offer tax credits for data center heat reuse.** States can reduce the economic barriers to deploy data center heat reuse by offering tax credits for these projects. These tax credits can be offered to the data center as the heat provider in the form of an investment tax credit or a production tax credit. A production tax credit could be calculated based on the million British thermal units (MMBtus) of heat provided to the offtaker or the megawatt hours (MWh) of electricity consumption the data center reduces.
- **Provide grants or low-interest loans for data center heat reuse projects.** These incentives could be designed specifically for data center heat reuse or allowed as a qualification to achieve another requirement of related grants or loans. For example, Washington State established the Industrial Symbiosis program in 2021 that offers competitive grants to projects that transform industrial waste, including heat, into an added-value resource for industry.<sup>40</sup> In 2023, DOE announced \$40 million in funding for projects that reduce data center’s electricity consumption. One of the 15 funding recipients is Raytheon, which is developing a system to remove heat from sources in servers using ribbon oscillating heat pipes.<sup>41</sup>

---

<sup>36</sup> EMB3Rs, “[Heat and Cold Matching Platform](#),” last acc. Apr. 2025.

<sup>37</sup> Virginia [HB2578](#).

<sup>38</sup> New York [SB9422](#).

<sup>39</sup> Building Decarbonization Coalition, “[Thermal Energy Networks](#),” last acc. Apr. 2025.

<sup>40</sup> RCW [43.31.625](#).

<sup>41</sup> U.S. DOE, “[DOE Announces \\$40 Million for More Efficient Cooling for Data Centers](#),” May 9, 2023.



## SOLUTIONS TO BARRIER 3: STANDARDS

- **Establish energy efficiency standards for data centers.** States can promote data center heat reuse by establishing energy efficiency standards for data centers and allowing heat reuse projects to meet those requirements. States could model policies on Germany’s Energy Efficiency Act, which establishes energy efficiency standards for new and existing data centers and requires new data centers to reuse an increasing percentage of their heat.<sup>42</sup> States could also implement this approach through energy efficiency standards for all buildings.
- **Require plans for heat reuse in permitting of data centers.** States can require plans for heat reuse in the permitting applications for data centers. For example, the Biden Administration issued an Executive Order that requires data centers built on federal land to submit a plan for maximizing energy, water, and other resource efficiency, including plans for “waste-heat utilization in constructing and operating the AI data center at the site” as a way to meet this efficiency goal.<sup>43</sup> Though the Trump Administration has not rescinded this Order, it has issued other AI Executive Orders.<sup>44</sup>
- **Establish a fee for a data center’s carbon emissions from electricity consumption.** States could promote data center heat reuse by establishing a fee for data centers based on the emissions from their electricity consumption. This could be modeled after legislation introduced at the federal level in 2025, the Clean Cloud Act. The Clean Cloud Act would, if established, charge data centers for their electricity emissions compared to the regional grid and reinvests the raised revenue into keeping residential electricity rates low and developing long-duration energy storage and clean firm generation.<sup>45</sup>

## CONCLUSION

Data center heat reuse represents a significant yet underutilized opportunity to reduce electricity demand, lower costs and emissions, and deliver cost-effective heating and cooling to nearby industries and buildings. While the technical potential is clear—reducing data center electricity demand by up to 30%—realizing these benefits requires strategic policy intervention. Countries like those in Europe are already demonstrating success, while the U.S. currently lags in unlocking this resource.

States can leverage data center heat reuse to combat electricity load growth by implementing enabling policies, offering financial incentives, and establishing performance requirements.

---

<sup>42</sup> German Federal Government, “[The public sector set to become a role model](#),” Apr. 19, 2023.

<sup>43</sup> The White House, “[Executive Order on Advancing United States Leadership in Artificial Intelligence Infrastructure](#),” Jan. 14, 2025.

<sup>44</sup> McGuireWoods, “[Trump Administration Executive Order Seeks to Deregulate Artificial Intelligence](#),” Feb. 11, 2025.

<sup>45</sup> [Clean Cloud Act of 2025](#).



## APPENDIX 1 — FURTHER EXPLANATION OF DATA CENTER COOLING METHODS

**Mechanical cooling** is used in open hall data centers, with air-conditioning used to maintain indoor temperature and humidity levels. This requires high amounts of electricity and water to operate the chillers.

**High efficiency mechanical cooling** uses a variety of technologies that are selected based on a specific location. Depending on the location, either water-cooled chillers or air-chilled coolers can be used, with medium electricity requirements.

**Adiabatic cooling**, the most common practice in the U.S., comprises both indirect and direct evaporative cooling. In indirect evaporative cooling, a radiator and the natural cooling effect of water evaporation is used to chill a special fluid. This chilled fluid then helps remove heat from the data center. In direct evaporative heating, air is passed through a wet material, which cools the air as the water evaporates. While direct evaporative heating has lower water usage, both practices require water. These methods have low electricity requirements compared to mechanical cooling.

**Free air cooling** is when the outside air is used for cooling year-round. Therefore, this practice is limited to continuously cold climates.

## APPENDIX 2 — POLICY OPTIONS FOR DATA CENTER HEAT REUSE

This appendix provides consolidated information on and links for the policies outlined in “The Call: State Policies.”

### ENABLING POLICIES

- **The European Union’s Heat and Cold Matching Platform:** This platform allows industries and facilities with surplus heating and cooling to identify those who need it. For more information, see: <https://www.emb3rs.eu/>.
- **Virginia H.B. 2578, “Retail Sales and Use Tax; exemption for data centers, reports,”** (failed): If passed, this legislation would direct the Virginia Department of Energy to “create and publish an interactive map of existing and proposed data centers and potential public and private heat users.” For more information, see: <https://lis.virginia.gov/bill-details/20251/HB2578>.
- **New York S.B. 9422, “Utility Thermal Energy Network and Jobs Act,”** (passed): This legislation directs utilities to establish thermal energy network pilot projects. Similar legislation has passed in California, Colorado, Massachusetts, Maryland, Minnesota, Washington, and Vermont. For more information, see: <https://legislation.nysenate.gov/pdf/bills/2021/S9422>.

### FINANCIAL INCENTIVES

- **Washington State, Industrial Symbiosis Grant Program:** This program offers competitive grants to projects that transform industrial waste, including heat, into an added-value resource for industry. For more information, see: <https://app.leg.wa.gov/RCW/default.aspx?cite=43.31.625>.
- **U.S. Department of Energy Cooling Operations Optimized for Leaps in Energy, Reliability, and Carbon Hyperefficiency for Information Processing Systems (COOLERCHIPS):** This



program provides grants for projects that reduce the energy needed to cool data centers. For more information and selected projects, see: <https://www.energy.gov/articles/doe-announces-40-million-more-efficient-cooling-data-centers>.

---

## STANDARDS

- **Germany Energy Efficiency Act** (passed): Establishes energy efficiency standards for new and existing data centers and requires new data centers to reuse an increasing percentage of their heat. For more information, see: [https://www.bundesregierung.de/breg-de/service/archiv-bundesregierung/the-energy-efficiency-act-2184958#:~:text=The%20new%20legislation%20establishes%20efficiency,Energy%20Efficiency%20Directive%20\(EED\)](https://www.bundesregierung.de/breg-de/service/archiv-bundesregierung/the-energy-efficiency-act-2184958#:~:text=The%20new%20legislation%20establishes%20efficiency,Energy%20Efficiency%20Directive%20(EED)).
- **U.S. “Executive Order on Advancing United States Leadership in Artificial Intelligence Infrastructure”**: Requires data centers built on federal land to submit a plan for maximizing energy, water, and other resource efficiency, including plans for “waste-heat utilization in constructing and operating the AI data center at the site” to meet this efficiency goal. For more information, see: <https://bidenwhitehouse.archives.gov/briefing-room/presidential-actions/2025/01/14/executive-order-on-advancing-united-states-leadership-in-artificial-intelligence-infrastructure/>.
- **U.S. “Clean Cloud Act of 2025”** (failed): Would, if established, charge data centers for their electricity emissions compared to the regional grid and reinvest the raised revenue into keeping residential electricity rates low and developing long-duration energy storage and clean firm generation. For more information, see: [https://www.epw.senate.gov/public/\\_cache/files/e/2/e2c78ea9-0e16-4588-888f-b9b2e57c3fb6/B99FED5139B823395EFC442BF75CF687E7275CBA19F73D8C9A3B5E3E5AF1474D.maz25018.pdf/](https://www.epw.senate.gov/public/_cache/files/e/2/e2c78ea9-0e16-4588-888f-b9b2e57c3fb6/B99FED5139B823395EFC442BF75CF687E7275CBA19F73D8C9A3B5E3E5AF1474D.maz25018.pdf/).

## APPENDIX 3 — EXISTING PROJECTS IN NORTH AMERICA

This Appendix provides a consolidated list of current and planned data centers that utilize waste heat reuse in both the United States and Canada.

---

## PROJECTS IN THE UNITED STATES

- **Westbank; San Jose, CA.** Westbank, a real estate developer, is planning to incorporate three data centers into its 4,000 residential unit net-zero community. The heat from the data centers will be reused in the community’s district heating system. For more information, see: <https://investor.pgecorp.com/news-events/press-releases/press-release-details/2025/PGE-Begins-Energy-Infrastructure-Upgrades-to-Bring-San-Joses-Net-Zero-Community-to-Life/default.aspx>
- **Westin Building Exchange; Seattle, WA.** Amazon’s headquarters in Seattle reuses heat from a neighboring data center at the Westin Building Exchange for space heating. The data center produces the equivalent of 11 MW per day of heat, 5 MW of which is used in Amazon’s district heating system, servicing two 37-story buildings and one 16-story building, with the ability to continue serving the campus as it builds out. The project avoids 80 million kilowatt hours of electricity use over 25 years. For more information, see: <https://www.districtenergy-digital.org/districtenergy/2017q4/MobilePagedReplica.action?pm=2&folio=8#pg10>



- **National Renewable Energy Lab; Golden, CO.** NREL pulls heat from its High-Performance Computing Data Center into an energy recovery water loop, from which heat is transferred to the facility's process hot water loop using heat exchangers. The process hot water loop provides heating to the office space and conference area and a snow melt loop in the courtyard of the facility's main entrance. For more information, see: <https://www.nrel.gov/computational-science/waste-heat-energy-reuse>
- **Wyoming Hyperscaler; Evanston, WY.** A data center in Wyoming that is in construction plans to use liquid cooling to reuse its heat both onsite—for hot water, heat tracing, HVAC heating, and snow melt—and offsite—at an adjacent indoor produce farm. The first phase of the data center is 30 MW, with plans to expand to a full campus of 120 MW. For more information, see: [https://wyominghyperscalewhitebox.com/uploads/1/3/5/1/135134386/whwb-7x24-presentation\\_fall\\_22\\_final.pdf](https://wyominghyperscalewhitebox.com/uploads/1/3/5/1/135134386/whwb-7x24-presentation_fall_22_final.pdf)
- **Notre Dame University; South Bend, IN.** Notre Dame University reuses heat from its on-campus data center for a proximate greenhouse. For more information, see: <https://www.sciencedirect.com/science/article/pii/S1364032123006342>
- **Syracuse University; Syracuse, NY.** Syracuse University reuses heat from its on-campus data center for a space heating in an adjacent office building. For more information, see: [https://researchcomputing.syr.edu/wp-content/uploads/GDC\\_facts-1.pdf](https://researchcomputing.syr.edu/wp-content/uploads/GDC_facts-1.pdf)

---

## PROJECTS IN CANADA

- **Q01 Campus; Quebec City, Canada.** The 142 MW Q01 AI data center is currently under construction and plans to reuse its heat. For more information, see: <https://www.qscale.com/q01-campus#download-data-sheet>
- **Equinix TR5; Toronto, Canada.** One of the numerous Equinix data centers in Toronto exports its heat for space heating in multiple residential buildings, a hotel, university, and local shopping center. For more information, see: <https://www.equinix.com/newsroom/press-releases/2024/06/-help-us-heat-our-neighbors-equinix-makes-data-center-heat-available-to-warm-nearby-buildings-and-swimming-pools>

## ABOUT DGA

David Gardiner and Associates (DGA) was founded in 2001 to serve as a strategic advisor to organizations and businesses seeking a sustainable future. Our firm combines expertise developing research and analysis with deep understanding of clean energy markets and policy. DGA has worked for foundations, businesses, and non-profit advocacy groups to develop strategies to identify and promote policies that will advance clean energy and a low-carbon economy.

## ACKNOWLEDGMENTS

**DGA Report Team:** David Gardiner, Anna Dixon, Emily Kent, and Hannah Schuster

**Suggested Citation:** David Gardiner and Associates, "Data Center Heat Reuse: The Opportunity for States," September 2025.