



eDART May 2016 Release Enhancements

eDART XML Users Group Meeting
5/4/2016

- Production
 - Release of May enhancements scheduled for Wednesday, May 25th.
- Sandbox
 - Release of March enhancements scheduled for week of May 2nd.
 - Updated XML Documents available at <http://pjm.com/pub/etools/edart/xmldocs/xmldoc.html>.
Search for 'Training Environment XSD as of 5/5'.

- May 2016 Enhancements:
 - Capacity Performance Impacts to eDART
 - Default Status Switch Tracking
 - Other Enhancements
- Other Discussion Topics
- Question & Answer Resolution Session

- A Hot Weather, Cold Weather or Maximum Generation Alert may require members to update Estimated Early Return in eDART for Planned Outage tickets.
 - Genticcreate tag: `<est_early_return_time>`
 - valid only for `<outage_type>forecasted planned</outage_type>`
 - optional: if not provided, defaulted to End Date.
 - date/time field: `yyyy-mm-ddThh:mm:ss`
 - Genticrevise tag: `<est_early_return_time>`
 - valid only for `<outage_type>forecasted planned</outage_type>` or `<outage_type>planned</outage_type>`

- When Dispatch implements a 72-hr Maintenance Outage recall, PJM will notify all affected gen owners verbally, and update all maintenance tickets in effect during the recall window with a **Recall Date**.
- If a recalled Maintenance outage is still active after the Recall time, it will be considered a forced outage and a **Forced Date** will be added to the ticket.
- More details covered in May 2 Education session:
<http://www.pjm.com/~media/committees-groups/committees/oc/20160502/20150502-capacity-performance-performance-assessment-hour-education.ashx>

- Genticreview tag: `<early_recall_time>`
 - valid only for `<outage_type>maintenance</outage_type>`
 - blank except when entered by PJM
- Genticreview tag: `<forced_date>`
- Recalled Outages Download:
 - Type = genrecalled
 - `<forced_date>` only displayed when available.

Note: review of the auto-approval rules is ongoing to align with Capacity Performance requirements.

- May 2016 Enhancements:
 - Capacity Performance Impacts to eDART
 - Default Status Switch Tracking
 - Other Enhancements
- Other Discussion Topics
- Question & Answer Resolution Session

- New functionality for Transmission Owners to indicate the Default Status of equipment after an outage.
 - Optional field.
 - Equipment can be added to transmission ticket for Default Status change only (equipment is not part of outage).
 - Default Status updated in eDART at the <interval_end>.
 - New tags in Newtranstic, Transticreview and Transticrevise.

Newtranstic, Transticrevise

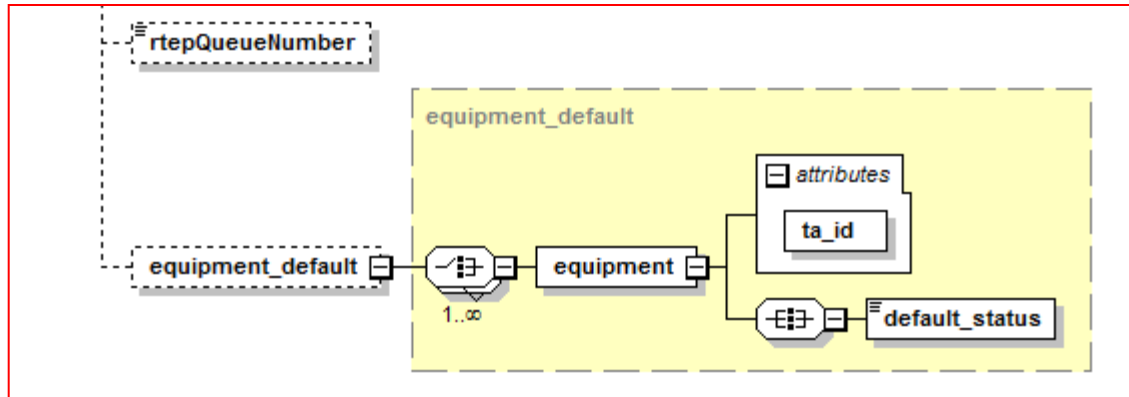

Transticreview

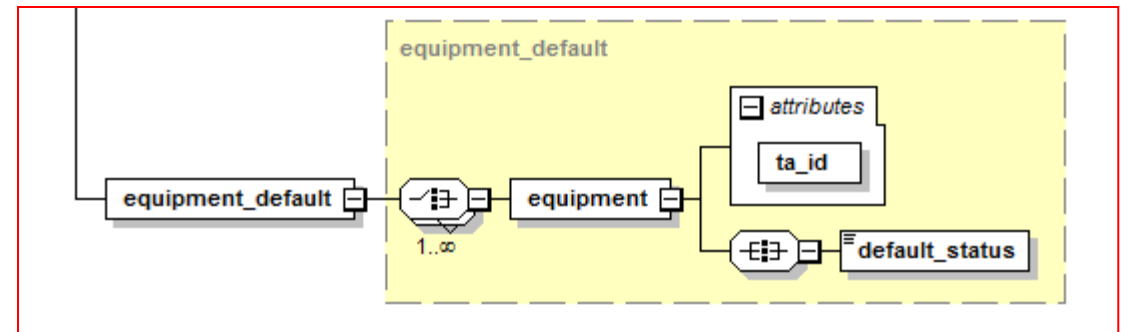

- May 2016 Enhancements:
 - Capacity Performance Impacts to eDART
 - Default Status Switch Tracking
 - Other Enhancements
- Other Discussion Topics
- Question & Answer Resolution Session

- The TOIMWG download updated to provide all data or no data.
 - Data is updated every 5 minutes on :03, :08, :13, :18, etc.
 - Message will be returned to user if data is being updated.
- ‘Include_all’ parameter for TERM Facilities download changed to ‘shownotify’ to be consistent with other TERM downloads.
- Duplicates in TERM Facilities download removed.
- Transtype parameter to be optional for REST API (default to transtype=review)
 - Optional on filetransfer.jar interface.

- Transticvrevise upload updated to allow edits to company_ticket_id.
 - To remove Company Ticket ID, upload:
 - <company_ticket_id/> OR
 - <company_ticket_id></company_ticket_id>
- <restplanreview> removed from Newtranstic (transcreate schema).
 - Requirement to identify impacted TOs removed.
- Today's Gencheckout report will be returned to the user if stop and start date parameters are not supplied.

- May 2016 Enhancements:
 - Capacity Performance Impacts to eDART
 - Default Status Switch Tracking
 - Other Enhancements
- Other Discussion Topics
- Question & Answer Resolution Session

- Coordinated Testing in Sandbox needed for XML changes:
 - Lesson learned from last release.
 - 2 hour conference call sessions to be scheduled.
 - eDART XML Support team available.
 - SMEs available to update tickets (lock, approve, activate, recall, etc.), start IRC, etc.
 - Members confirm all uploads/downloads used.
 - REST API and File Transfer testing.

- Dormant accounts are accounts which have not been logged into for the last 12 months.
- Timeline:
 - Currently: notifying Company Account Managers (CAMs) of dormant accounts.
 - 6/20: dormant accounts will be locked.
 - 3/31/2017: dormant accounts revoked.

- May 2016 Enhancements:
 - Capacity Performance Impacts to eDART
 - Default Status Switch Tracking
 - Other Enhancements
- Other Discussion Topics
- Question & Answer Resolution Session

- edart_xml_support@pjm.com
- edarthelp@pjm.com
- Chidi Ike-Egbonu: chidi.ike@pjm.com
- Michael Zhang: michael.zhang@pjm.com