



# PJM Proposal for Public Distribution Microgrids and Microgrid Generation

Andrew Levitt  
Sr. Market Design Specialist  
Market Design and Economics

SOS  
November 2, 2020

# Conceptual 1-line of **Public Distribution Microgrid**

- A **microgrid** is a system of generation + load that can run on-grid or off-grid.
- A 'Public Distribution Microgrid' **is operated by the distribution utility** and uses **public** utility **distribution** wires to serve load during islanding.
- A Public Distribution Microgrid Generator is a PJM wholesale unit owned by 3d party or utility.

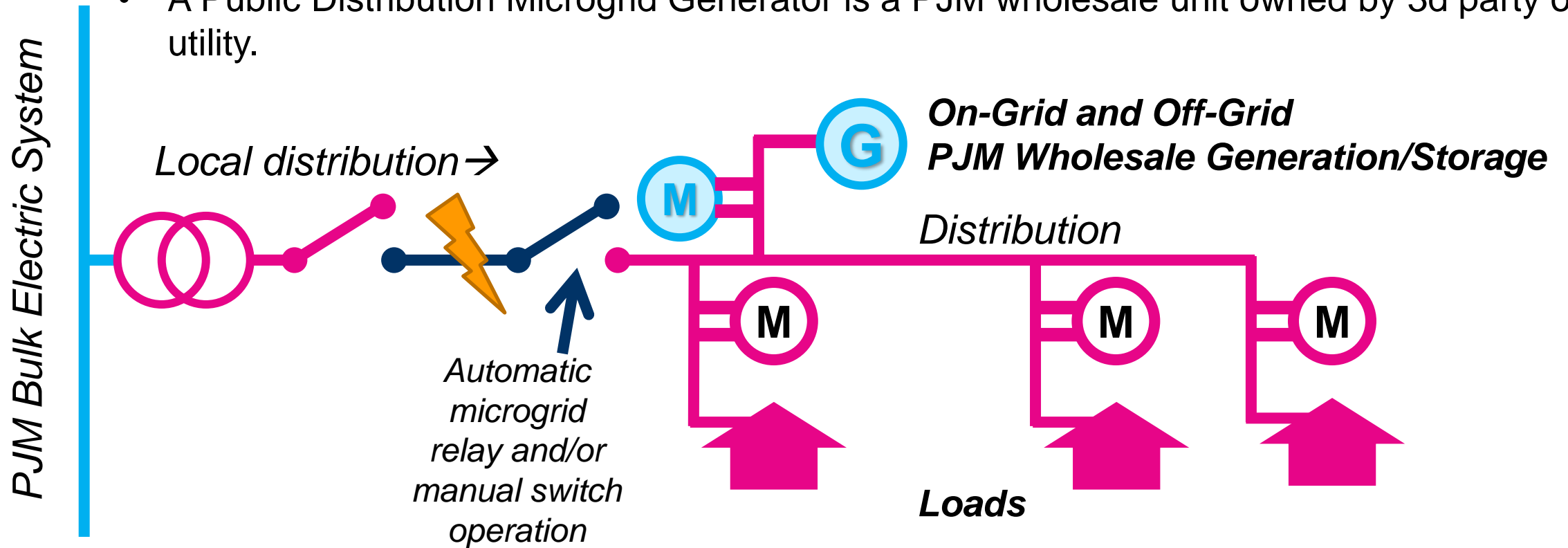

- Only microgrids that include “dual use utility distribution facilities” are PDM (ensures PDM are **public** and **distribution**).
- Exclusion for anything with BES or Transmission Facilities (ensures PDM are **distribution** and not transmission)
- A PDM Generator by definition is a **PJM generator**—it sells its output to PJM as a front of meter generator.

*“Public Distribution Microgrid shall mean a Microgrid that includes a **PJM Generation Capacity Resource or Energy Resource** that is capable of generating both while connected to and while islanded from the broader grid, **and which also includes dual use utility distribution facilities**. A Public Distribution Microgrid **may not include any NERC Bulk Electric System components nor any Transmission Facilities**.”*

**Microgrid:** *“A Microgrid is a defined set of generation and load that can operate both while connected to and while islanded (i.e., isolated) from the broader grid. A microgrid must include load, one or more generators, one or more switches for isolating and connected to the broader grid, and a microgrid controller. A microgrid could include public utility distribution facilities.”*

- “**Public Distribution Microgrid Operator** shall mean an Electric Distributor that controls a Public Distribution Microgrid, or a Member that an Electric Distributor has designated to control a Public Distribution Microgrid on an Electric Distributor’s behalf. Control of a Public Distribution Microgrid means control of switch gear, relays, microgrid controller and other equipment required to island generation and load in a Public Distribution Microgrid.”
- “**Public Distribution Microgrid Generator** is any share of a generator in a Public Distribution Microgrid that is a **Generation Capacity Resource or Energy Resource** and that is capable of generating both while connected to and while islanded from the broader grid.”

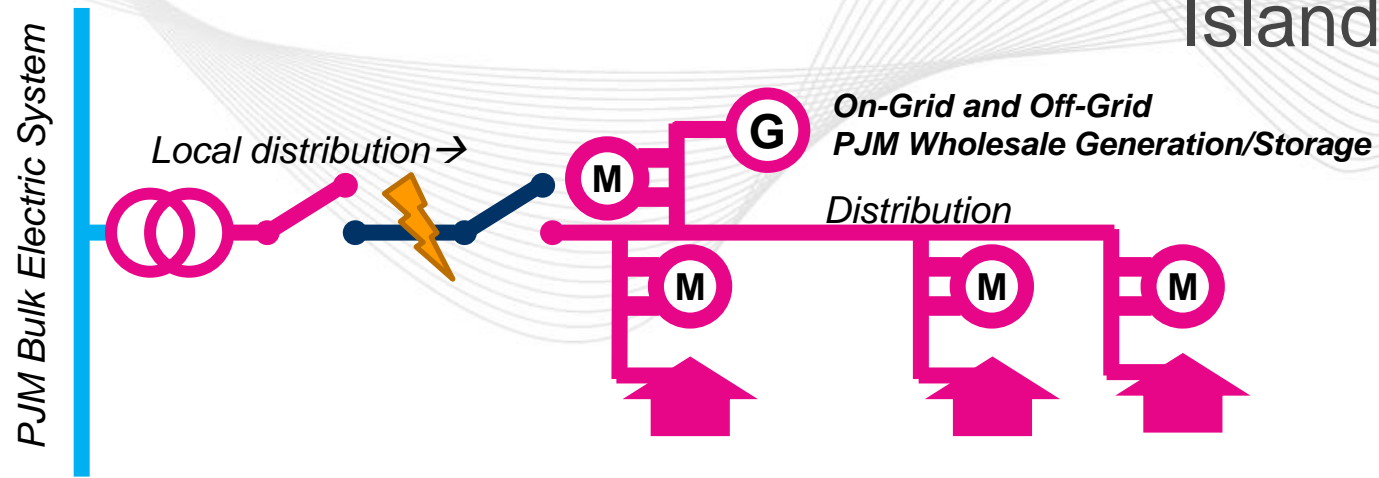

- Recall that a PDM Generator by definition is a PJM generator—it sells its output to PJM as a front of meter generator.
- Electric Distribution Company is responsible for:
  1. Quantifying PJM load and verifying PJM generation for their zone
  2. Operating their Public Distribution Microgrids
- An Electric Distribution Company that chooses to include islanded load as part of PJM load submissions should expect any corresponding PDM Generator supply to be submitted as PJM energy sales. This would be a “wholesale-islanded PDM”.
- An Electric Distribution Company that chooses to exclude islanded load from PJM load submissions should expect any corresponding PDM Generator supply to be zero, even if the PDM Generator were producing power. This would be a “retail-islanded PDM”.

Public Distribution Microgrid (“Public Distribution Microgrid shall mean a Microgrid that includes a PJM Generation Capacity Resource or Energy Resource that is capable of generating both while connected to and while islanded from the broader grid, and which also includes dual use utility distribution facilities. A Public Distribution Microgrid may not include any NERC Bulk Electric System components nor any Transmission Facilities.”)

## Grid connected

- Gen is settled through PJM
- Load is settled through PJM

## Islanded

Wholesale-islanded PDM:  
EDC chooses to operate as wholesale when islanded

**-OR-**

Retail-islanded PDM:  
EDC chooses to operate as retail when islanded

- Gen is settled through PJM
- Load is settled through PJM

*Public Distribution Microgrid Generator:*

- eDART outage (Ops reality)
- EFORd impact based on partial outage: actual PJM load unit can serve vs. ICAP
- Actual output credited for PAI performance

- Gen is not settled through PJM
- Load is not settled through PJM

*Public Distribution Microgrid Generator:*

- eDART outage (Ops reality)
- EFORd impact consistent with unit 100% unavailable to serve PJM load
- PAI: Actual Performance of 0 MW → shortfall



- The Public Distribution Microgrid Generator operator shall notify PJM of the start and end of planned and actual islanded conditions as soon as practicable. To facilitate that notification, the Public Distribution Microgrid Operator shall provide all necessary information to the Public Distribution Microgrid Generator operator on an ongoing basis.

In title of manual section: “voluntary guideline”

A Public Distribution Microgrid Operator shall not "economically island". The only acceptable reasons for the Public Distribution Microgrid Operator to island include:

1. An emergency situation on the distribution and/or transmission system, or a situation impacting system restoration;
2. An emergency situation on the transmission system, as defined by PJM Emergency Procedures, in which load shedding action is directed by PJM
3. Emergency declaration by appropriate local, state, or federal authority
4. Testing
5. Distribution facility maintenance

After islanded, a Public Distribution Microgrid Operator must reconnect the Public Distribution Microgrid as soon as reasonably possible.



- “When in island mode, an operator of a Public Distribution Microgrid Generator shall de-assign it from any existing Ancillary Services commitments (performance will be assessed as normal), and shall ensure it is not assigned for ancillary services for future intervals unless it is certain it will not be islanded in those intervals.”

- A Public Distribution Microgrid Generator shall meet existing telemetry requirements for all PJM generators. In addition, if it has real-time data on whether it is islanded or not, it shall provide that data to PJM.
- A Public Distribution Microgrid Operator shall provide to Public Distribution Generators the real-time status of any switching and/or relay that indicates the status of the Utility Microgrid (i.e.. Open, closed, island, etc.).

- A Transmission Owner that is planning, or has a distribution affiliate that is planning, a Public Distribution Microgrid with automatic separation should, if possible, provide PJM with the details of how the relay would automatically open the switch.

# Wholesale-islanded PDM Gen: Outage Reporting, EFORd, and CP Compliance

1. If PDM Generator is not broken, no forced outage for GADS (consistent with NERC guidelines for GADS reporting).
2. Any islanded PDM Generator should enter a full eDART outage when islanded, consistent with operating reality of the PJM BES.
3. When a **wholesale-islanded** Public Distribution Microgrid Generator is islanded, it is **still** supplying PJM load.
4. In general, PDM Generator ICAP is expected to exceed PDM load when islanded, by design. Thus, PDM Generator would likely generate at less than ICAP when islanded. Nonetheless, EFORd would not be otherwise impacted by islanding of a wholesale-islanded PDM Generator.
5. For PDM Generators that are Generation Capacity Resources: PAI Expected Performance is what it would have been if PDM were grid-tied (for example, at cleared UCAP\*balancing ratio). For wholesale-islanded PDM generators: PAI Actual Performance is it's actual output.

## Retail-islanded PDM Gen: Outage Reporting, EFORd, and CP Compliance

1. If PDM Generator is not broken, no forced outage for GADS (consistent with NERC guidelines for GADS reporting).
2. Any islanded PDM Generator should enter a full eDART outage when islanded, consistent with operating reality of the PJM BES.
3. When a **retail-islanded** Public Distribution Microgrid is islanded, the PDM Generator **is not** supplying PJM load.
4. EFORd will be impacted by islanding of a retail-islanded PDM Generator, since it is not available to serve PJM load.
5. For PDM Generators that are Generation Capacity Resources: PAI Expected Performance is what it would have been if PDM were grid-tied (for example, at cleared UCAP\*balancing ratio). For retail-islanded PDM Generators: the unit would get 0 MW of Actual Performance during a PAI, and therefore face a shortfall equal to the Expected Performance.

Facilitator:

Rebecca Carroll, [Rebecca.Carroll@pjm.com](mailto:Rebecca.Carroll@pjm.com)

Secretary:

Paul Dajewski, [Paul.Dajewski@pjm.com](mailto:Paul.Dajewski@pjm.com)

Presenter:

Andrew Levitt, [andrew.levitt@pjm.com](mailto:andrew.levitt@pjm.com)

Natalie Tacka, [natalie.tacka@pjm.com](mailto:natalie.tacka@pjm.com)

## Public Distribution Microgrids

A green circular icon containing a white question mark, positioned above a blue speech bubble icon.A large yellow circular icon containing the text for the Member Hotline, positioned to the right of the contact information.

(610) 666 – 8980

(866) 400 – 8980

[custsvc@pjm.com](mailto:custsvc@pjm.com)