

The Dayton Power & Light Co

# Requirements for the Connection of Facilities to The Dayton Power & Light Co. Transmission System

Compliance to NERC Standard FAC-001-3

January 2019

## Table of Contents

<b>INTRODUCTION</b> .....	<b>3</b>
<b>NERC STANDARD FAC-001-3 REQUIREMENTS</b> .....	<b>5</b>
<b>R1 Each Transmission Owner shall document Facility interconnection requirements, update them as needed, and make them available upon request.</b> .....	<b>5</b>
<b>R3.1 Procedures for coordinated studies of new or materially modified existing interconnections and their impacts on affected system(s).</b> .....	<b>5</b>
<b>R3.2 Procedures for notifying those responsible for the reliability of affected system(s) of new or materially modified existing interconnections.</b> .....	<b>6</b>
<b>R3.3 Procedures for confirming with those responsible for the reliability of affected systems that new or materially modified Facilities are within a Balancing Authority Area’s metered boundaries.</b> ..	<b>6</b>
<b><i>Voltage level and MW and MVAR capacity or demand at point of connection.</i></b> .....	<b>7</b>
<b><i>Breaker duty and surge protection.</i></b> .....	<b>7</b>
<b><i>System Protection and Coordination.</i></b> .....	<b>8</b>
<b><i>Metering and telecommunications.</i></b> .....	<b>10</b>
<b><i>Grounding and safety issues.</i></b> .....	<b>11</b>
<b><i>Insulation and insulation coordination.</i></b> .....	<b>12</b>
<b><i>Voltage, Reactive Power, and power factor control.</i></b> .....	<b>12</b>
<b><i>Power quality impacts.</i></b> .....	<b>14</b>
<b><i>Equipment Ratings.</i></b> .....	<b>14</b>
<b><i>Synchronization of Facilities.</i></b> .....	<b>15</b>
<b><i>Maintenance coordination.</i></b> .....	<b>15</b>
<b><i>Operational issues (abnormal frequency and voltages).</i></b> .....	<b>15</b>
<b><i>Inspection requirements for existing or new Facilities.</i></b> .....	<b>16</b>
<b><i>Communications and procedures during normal and emergency operating conditions.</i></b> .....	<b>17</b>
<b>NEW LOAD AND GENERATION CONFIGURATION</b> .....	<b>19</b>
<b>DEFINITIONS</b> .....	<b>23</b>
<b>REVISION HISTORY</b> .....	<b>25</b>

## **Introduction**

The Dayton Power and Light Company (DP&L) has prepared this Facilities Connection Requirements document to ensure compliance with North American Electric Reliability Council (NERC) Reliability Standards and applicable Regional Reliability Organization, subregional, Power Pool, and individual Transmission Owner planning criteria and facility connection requirements in compliance to NERC Standard FAC-001-3. The purpose of NERC Standard FAC-001-3 is to require Transmission Owners and Generator Owners to establish facility connection and performance requirements to avoid adverse impacts on reliability for additions to the transmission system. These connection requirements apply to all generation facilities, transmission facilities, and end-users connecting to the DP&L transmission system.

DP&L is registered as a Transmission Owner with NERC. PJM serves as the Transmission Service Provider, Planning Authority, Transmission Planner, Resource Planner, Reliability Coordinator, and Transmission Operator for DP&L. PJM operates its transmission system in compliance with NERC Reliability Standards, Reliability *First* Corporation (RF) standards, and PJM standards. Since PJM is the Transmission Service Provider for the DP&L transmission system, all entities requesting interconnection of a generating facility (including increases to the capacity of an existing generating unit or decommissioning of a generating unit) or requesting interconnection of a merchant transmission facility within the DP&L transmission system must do so within PJM's defined interconnection process. See the PJM website <http://www.pjm.com> to obtain information about submitting requests for interconnecting to the transmission system. The PJM Manual 14 series address the interconnection process, planning study requirements, and facility connection requirements specific to the PJM transmission system.

**PJM Manual 14A** – Guides the generation and/or transmission developers through the planning processes to interconnect to and operate in PJM markets.

**PJM Manual 14B** – PJM Regional Transmission Planning Process focuses on the process for planning baseline expansion facilities under the PJM Region Transmission Planning Process. This planning process culminates in the Regional Transmission Expansion Plan (RTEP). The PJM RTEP process consists of baseline reliability reviews as well as analysis to identify the transmission needs associated with generation interconnection and merchant transmission interconnection.

**PJM Manual 14C** – Provides PJM process guidelines for the construction and integration of all RTEP projects, including generation and merchant transmission interconnections and Transmission Owner upgrades.

**PJM Manual 14D** – Generator Operational Requirements is one of the PJM procedure manuals. It focuses on the generation markets and operational requirements for generating entities to connect to the PJM system and their responsibilities as signatories to the Operating Agreement of PJM Interconnection, L.L.C.

**PJM Manual 14E** – Provides the specific requirements for interconnecting Merchant Transmission Facilities, proposing capability increases to specific Transmission Owner Facilities and making Upgrade Requests to obtain Incremental Auction Revenue Rights (IARRs) under PJM's Regional Transmission Expansion Planning Process. Additionally, it describes the various rights available and agreements required to complete the Transmission Interconnection or Upgrade planning process.

**PJM Manual 14G** – Guides a Generation Interconnection customer through their application, study and agreement process including specific requirements and rights as a generator participating in PJM markets.

PJM Manual 14A explains how other parties are notified of new or modified facilities through the PJM RTEP process. In order to initiate the Interconnection Planning Process, the developer must submit a completed Interconnection Request to PJM. This is accomplished via the execution of a Feasibility Study Agreement. The procedures used to process the requests for interconnection with the transmission system include three analytical steps:

1. Feasibility Study

The Feasibility Study assesses the practicality and cost of incorporating the generating unit or increased generation or transmission capacity into the PJM system. The analysis is limited to short-circuit studies and load-flow analysis of probable contingencies. This study does not include stability analysis. The study also focuses on determining preliminary estimates of the type, scope, and lead time for construction of the Transmission Owner’s facilities required to interconnect the project.

2. System Impact Study

The System Impact Study is a comprehensive regional analysis of the impact of adding the new generation and/or transmission facility to the system and an evaluation of their impact on deliverability to PJM load in the particular PJM region where the generator and/or new transmission facility is located. This Study identifies the system constraints relating to the project and the necessary Attachment Facilities, Local Upgrades, and Network Upgrades. The study refines and more comprehensively estimates cost responsibility and construction lead times for facilities and upgrades.

3. Interconnection Facilities Study

The Interconnection Facilities Study will document the engineering design work necessary to begin construction of any required transmission facilities. The Study also will provide a good-faith estimate of the cost to be charged to the applicant for Attachment Facilities, Local Upgrades and Network Upgrades necessary to accommodate the project and an estimate of the time required to complete detailed design and construction of the facilities and upgrades.

PJM will coordinate with all impacted utilities any request for connections that impact the lines of other interconnected utilities. This document is intended to highlight the minimum DP&L requirements and is not intended to fully replicate or to replace the PJM documentation. The scope of this document is limited to the technical requirements for connected facility design and operation. Parties requiring transmission service should refer to the PJM Open Access Transmission Tariff (OATT) to reserve and secure transmission service for their generation.

If there is a conflict between this document and the PJM documents, then the PJM Agreements take precedent and should be discussed between all the parties.

The paragraph headings in this document correspond to the NERC FAC-001-3 requirement numbers.

## **NERC Standard FAC-001-3 Requirements**

### **R1 Each Transmission Owner shall document Facility interconnection requirements, update them as needed, and make them available upon request.**

The impact of the interconnection customer's facilities on the reliability of the transmission system shall be evaluated through the PJM Interconnection Request process. Studies are performed by PJM in conjunction with DP&L and in accordance with established NERC, RF, PJM and DP&L Transmission Planning Criteria to ensure continued compliance to the established criteria throughout the planning horizon.

#### **Generation and Merchant Transmission Interconnect Requests**

The studies performed by PJM and DP&L as part of the Interconnection Planning Process described in PJM Manual 14A will determine the impact of the interconnection request on the reliability of the transmission system. These studies also identify any transmission system upgrades required to ensure the system continues to operate in accordance with the established criteria. The results of these studies are posted on the PJM website.

#### **Transmission Interconnection – Transmission Owner to Transmission Owner**

The studies performed by PJM along with transmission owners as part of the RTEP process as described in PJM Manual 14B determine if there are needs for additional transmission upgrades across multiple transmission owner systems in order to ensure continued compliance to the established planning criteria. Any upgrades identified become part of the PJM Regional Transmission Expansion Plan, which is documented on the PJM website.

#### **End-User Interconnection Requests**

End-User requests are evaluated by DP&L to determine if the interconnection would result in any adverse impacts to the transmission system. If the interconnection would not allow the continued operation in compliance to the established planning criteria, system upgrades and estimated costs would be identified that would allow continued operation in compliance to the established planning criteria. These system upgrades will be made known to the interconnection requestor.

### **R3.1 Procedures for coordinated studies of new or materially modified existing interconnections and their impacts on affected system(s).**

PJM is responsible for coordinating joint studies of new facilities and their impacts on the interconnected transmission system. PJM Manual 14 series of documents describe the process PJM uses for coordinating joint studies. Load flow and short circuit analysis are performed as part of the feasibility study. Stability studies are performed in the system impact study phase of the process. PJM Manual 14A defines the data requirements needed from the developer to perform the feasibility and system impact studies. The results of the PJM studies for Generation and Merchant Transmission Interconnection requests are posted on the PJM website. Summary study results for transmission interconnections are published annually by PJM as part of the PJM RTEP process.

End-Users desiring to connect to the DP&L transmission system must complete a Business/Non-Residential packet. This packet is located on the DP&L website at [www.dpandl.com](http://www.dpandl.com) and requests basic information including load data, type of service, and voltage levels desired. DP&L will study any End-User request for connection to the

transmission system and provide interconnection alternatives that will ensure the system continues to operate in accordance with the established criteria.

### **R3.2 Procedures for notifying those responsible for the reliability of affected system(s) of new or materially modified existing interconnections.**

Any customer desiring to add new facilities or modify existing facilities must notify PJM and DP&L as soon as feasible. These changes will be analyzed for any adverse impacts on the transmission system. Any changes to power output levels must follow the requirements of PJM Manual 14A. Any switching performed by the interconnect customer that results in abnormal operating conditions must be promptly reported to PJM and DP&L in advance for planned operations or as soon as feasible for emergency conditions.

### **R3.3 Procedures for confirming with those responsible for the reliability of affected systems that new or materially modified Facilities are within a Balancing Authority Area's metered boundaries.**

Interconnecting customers are required to notify the required parties in R3.2. In PJM's assessment of proposed facilities, there is verification that the customer is within the metered bounds through the PJM Open Access Transmission Tariff (OATT), through the PJM Regional Transmission Expansion Process, and the New Services Request process. The OATT states that a customer proposing to connect to the Transmission System in the PJM Region needs to request interconnection with the Transmission System and will comply with applicable terms and conditions set forth in the tariff. As a result of this requirement, all new or modified facilities that want to interconnect or upgrade onto the PJM system (Balancing Authority) must come through the New Services Queue. All approved projects are given an Interconnection Service Agreements or Construction Service Agreements which are sent to FERC for review and approval.<sup>1</sup> These agreements are confirmatory evidence of compliance to FAC-001-3 that the proposing interconnection customer is within the metered bounds of the applicable balancing authority.

---

<sup>1</sup> PJM Compliance Bulletin CB028, NERC Standard FAC-001-3 - Facilities within the metered boundaries of a Balancing Authority.

***Voltage level and MW and MVAR capacity or demand at point of connection.***

The typical voltage range on the transmission system is from 90% to 105% of the nominal transmission voltages, which are 345kV, 138kV and 69kV. Generation facilities and Transmission facilities must be capable of continuous non-interrupted operation within a steady-state voltage range during system normal and single facility outage conditions. During emergency and/or transient system conditions, voltages may temporarily be outside the 90% to 105% range and all reasonable measures should be taken to avoid tripping of the Generation and/or Transmission facilities due to high or low voltage. The End-User must recognize the potential voltage ranges on the transmission system and install their own voltage regulating equipment if they need a more restrictive voltage range for their equipment. The End-User also must recognize there will be temporary excursions outside the typical voltage range and is responsible for providing any voltage sensing equipment required to protect their equipment during abnormal voltage operation.

Generation facilities desiring to connect to the transmission system must submit the MW capacity and energy and MVAR capability to PJM. These values will be used in the PJM studies to determine the impact of the interconnection to the reliability of the transmission system.

Parties desiring to connect their transmission system with DP&L's transmission system should be able to supply their own reactive power requirements unless mutually agreed to other arrangements. Transmission interconnections must be sized to handle the potential MW and MVAR flow under emergency conditions considered in the established planning criteria.

End-users desiring to interconnect to DP&L's transmission system must supply information on characteristics of load, such as initial and near future expected load (MW and MVAR), power factor of such load, voltage level at point of interconnection, and dynamic (flicker, harmonics, etc.) character of such load. This information will be requested on the Business/Non-Residential packet to be filled out by the customer.

***Breaker duty and surge protection.***

The Applicant must provide a three-phase interrupting device(s) with appropriate relays and/or other protective equipment to isolate their facility from the DP&L system for any faults, loss of supply from DP&L or abnormal operating conditions, whether or not their facility is operating. This device shall fully comply with the latest ANSI/IEEE C37 collection of standards and be capable of interrupting the maximum available fault current at that location. The device shall interrupt all three phases simultaneously. The tripping control of the circuit interrupting device shall be powered independently of the utility ac source in order to permit operation upon loss of the DP&L transmission system connection. Automatic reclosing of the Applicant's facilities is not permitted unless a special agreement is worked out with DP&L. All gas insulated protective devices within the Applicant's facility having a direct connection to a DP&L transmission line shall be equipped with a low gas pressure alarming/tripping/lockout scheme as appropriate for the particular device.

Lightning arresters protecting transformers are generally mounted on the transformer. However, since lightning arresters can adequately protect equipment some distance from the arresters, the overall number of lightning arresters required in each design can be

reduced. Allowable lightning arrester separation distance from the equipment being protected shall be determined by the latest edition of IEEE Std. C62.22 IEEE Guide for the Application of Metal-Oxide Surge Arresters for Alternating –Current Systems. The Applicant should consult the manufacturer’s catalog for details concerning arrester protective characteristics, ratings, and application.

The minimum substation Basic Impulse Levels (BIL) and arrester ratings for DP&L are shown below:

Nominal System Voltage	Substation Bus BIL (kV)	Bank Arrester (kV)	Line Arrester (kV)	Switch Rating (kV)	Transformer BIL (kV) Internal
69	350	60	60	72	350/350
138	550	108	108	115	550/650
345	1300	276	276	345	1050/1300

***System Protection and Coordination.***

Generation facilities, transmission facilities, and end-user facilities connecting to the DP&L transmission system are responsible for determining that the proper protective equipment meet all applicable standards, is properly installed and coordinates with DP&L relaying. Protective relaying systems and associated communications systems for all facility interconnections shall be planned, designed, constructed, and maintained in accordance with applicable NERC, RF, and PJM standards. Utility grade protective relays and fault clearing systems are to be utilized on the interconnected power system. Utility grade relays are defined as follows:

- Meet ANSI/IEEE Standard C37.90, *Relays and Relay Systems Associated with Electric Power Apparatus.*
- Have relay test facilities to allow testing without unwiring or disassembling the relay.
- Have appropriate test plugs/switches for testing the operation of the relay.
- Have targets to indicate relay operation.

The Applicant must take responsibility for providing adequate system protection to its facilities and to DP&L facilities under any transmission operating condition, whether or not their facilities are in operation. Conditions may include but are not limited to:

- Single phasing of supply
- System faults.
- Equipment failures.
- Abnormal voltage or frequency.
- Lightning and switching surges.
- Excessive harmonic voltages and/or currents.
- Excessive negative sequence voltages
- Separation from DP&L.
- Synchronizing of generation to the DP&L system.

DP&L reserves the right to specify functional specifications and relay settings deemed necessary to avoid safety hazards or to prevent any disturbance, impairment or interference with DP&L’s ability to serve other customers. The criteria for these functional specifications and settings will be based on existing DP&L protection practices. DP&L reserves the right to specify the type and manufacturer for these protective relays to ensure compatibility with existing relays. DP&L will make the



specific recommendations and requirements for protection based on the individual substation location, voltage and configuration.

For generation facilities, the relay protection system may be part of a self-contained generation control package. Additional relay protection may be required if testing or operational problems are encountered with this self-contained generation control package. DP&L shall review the interface protection and/or the self-contained protection schemes included with the generation before the unit will be permitted to connect to the DP&L system. The following relay functions are required by the Applicant for protection of the DP&L system. Use of the transfer trip receiver is conditional as set forth below.

<u>Relay</u>	<u>Purpose</u>
Frequency	To detect under and over frequency operation and separate the customer’s parallel generation.
Under/over voltage	To detect under and over voltage operation and cause separation of the customer’s parallel generation.
Transfer Trip Receiver	To receive a trip signal from a DP&L transfer trip transmitter and separate the customer’s parallel generation.
Ground Detector	To detect a ground fault on the DP&L or customer system and separate the customer’s parallel generation.
Directional Power	To detect a reverse power flow condition and separate the customer’s parallel generation.

The purpose of these relays is to detect the Generation Owner’s energizing of a DP&L circuit that has been isolated from the DP&L system, by circuit breaker or other disconnect device operations or detect the generation operating at an abnormal voltage or frequency, or to detect a fault or abnormal condition on the DP&L system requiring the Generation Owner to separate their generation from the DP&L system. Output contacts of these relays shall directly energize the trip coil(s) of the generation breaker or an intermediate auxiliary tripping relay that directly energizes the breaker trip coil(s). The relaying system shall have a power source independent from the ac system or immune to ac system loss or disturbances (e.g., dc battery and charger) to assure proper operation of the protection scheme. Loss of this source shall cause removal of the generation from the DP&L system.

DP&L will specify settings for the generation’s DP&L-required relays to ensure coordination between the generation protective equipment and the DP&L system relays. It is the Generation Owner’s responsibility to determine that their internal protective equipment coordinates with the required DP&L protective equipment and is adequate to meet all applicable standards. DP&L reserves the right to modify relay settings when deemed necessary.

A transfer trip relaying system (or other not specified above) must be installed at the Generation Owner's expense if DP&L determines it is necessary to protect the Transmission System. The transfer trip relaying system shall consist of all transfer trip transmitters located at DP&L facilities, transfer trip receivers at the Generation Facility and the communication channels between the DP&L location(s) and the Generation Facility.

***Metering and telecommunications.***

*Metering* - At the Applicant's expense, DP&L will install, own, operate and maintain the metering equipment at the delivery point. The Applicant must provide any necessary space for this metering equipment. The metering equipment will include potential and current transformers, meters and test switches. The accuracy of the instrument transformers and meters will be 0.3 percent or better. The secondary wiring and burdens of the instrument transformers will be configured so that they do not degrade the accuracy of the metering equipment to less than 0.3 percent. The metering equipment shall be tested periodically as defined in the connection or service agreement and the test results will be available to all involved parties. The meters, test switches and wiring termination equipment will be sealed and the seal may be broken only when the meters are to be tested, adjusted or repaired. Proper authorities in both parties will be notified when seals are broken. At least (N-1) metering elements will be used to measure all real and reactive power crossing the metering point, where N is the number of wires in service including the ground wire. Bi-directional energy flows including watt-hour and var-hour will be separately measured on an hourly basis. Depending on the tariffs to be applied, appropriate demand quantities will be metered in terms of kilowatts, kilovars or kilovolt-amperes. The meters will have a separate register for loss compensation.

*Revenue Metering* - DP&L approved revenue class metering equipment shall be installed at the delivery point to meter the aggregated load of the connected facility consisting of instantaneous bi-directional real and reactive power and integrated hourly real and reactive energy metering. The instrument transformers used for revenue metering shall be installed on the high voltage side of the connecting party's step-down transformer. Under special circumstances and with written approval granted by DP&L, revenue metering may be performed on the low voltage side of the step-down transformer. Written approval shall only be given if the connecting party can demonstrate that accurate transformer loss compensation will be programmed into the revenue metering when instrument transformers are installed on the low voltage side of the step-down transformer or accepts a 1% differential between the low side and high side.

*Telecommunications* - If, at the discretion of DP&L, the interconnection necessitates real-time telemetry to the PJM and/or DP&L Transmission Control Center, DP&L will install, own, operate, and maintain, at the Applicant's expense, the communication channel, the telemetry equipment and associated devices. Suitable telemetry equipment shall be installed at the metering point to provide real-time telemetry data to DP&L and to all other participating parties. Telemetry equipment will include transducers, remote terminal units, modems, telecommunication lines, and any other equipment of the same or better function. The remote terminal unit, or equivalent device, must have multiple communication ports to allow simultaneous communications with all participating parties. That device will accommodate data communication requirements specified by each participating parties' control center, including communication protocol, rate and mode (either synchronous or asynchronous). All metered values provided to the telemetry equipment will originate from common metering equipment. All transducers used for telemetry will have at least 0.2 percent accuracy. As part of real-time data to be provided,

DP&L has the right to require the status and remote control of switching devices at the Receipt and/or Delivery Points. A continuous, accumulating record of megawatt-hours and megavar-hours will be provided by means of the registers on the meter. Freezing accumulation data for transmission will be taken every clock hour. The freezing signals synchronized to within 2 seconds of Universal Coordinated Time must be provided by only one of the agreed-upon participating parties. If the freeze signal is not received within a predefined time window, the remote terminal unit, or equivalent device, will be capable of freezing data with its own internal clock. The metering, if external power supply is required, and telemetry equipment will be powered from a reliable power source, such as a station control battery, in order to allow the equipment to be continuously operational under any power outage situations. Proper surge protection will be provided for each communication link to protect communication hardware from ground-potential-rise due to any fault conditions. A separate communication media shall be provided to allow DP&L to remotely retrieve billing quantities from the meters. When real-time telemetry is required, a back-up data link must be provided in case of the outage of the primary telemetry line. The back-up link can be a data communication link between involved control centers; the party requesting service is responsible for furnishing the back-up link. At the discretion of DP&L, generation control facilities and supervisory control and data acquisition of specific electrical devices from the PJM and/or DP&L Transmission Control Center may be necessary to integrate the generation into PJM's control area. Such additional facilities, including required communication channels, shall, if required, be furnished and installed at the Generation Owner's expense. The requirement for data acquisition and control will depend on the generation capacity, system location and voltage, and the net generation input into DP&L System. Data acquisition and control information will typically include, but not be limited to:

- desired generation MW set point,
- automatic generation control status (on, off),
- generator availability,
- generation MW, Mvar output,
- generator minimum and base MW capability,
- generator MW AGC high limit and low limit,
- connection facilities' breaker status/control/alarms,
- connection facilities' MW and Mvar line values and bus voltage, and
- generator and substation metering (MWh) data.

***Grounding and safety issues.***

Safety is of utmost importance. Strict adherence to established switching, Lock Out/Tag Out procedures, and grounding procedures is required at all times for the safety of personnel. Any work carried out within a facility shall be performed in accordance with all applicable laws, rules, and regulations in compliance with Occupational Safety and Health Administration (OSHA), NESC, and good utility practice. Automatic and manual disconnect devices are to be provided as a means of removing all sources of current to any particular element of a power system. DP&L personnel must be granted 24x7 access for emergency patrol or tagging purposes. Only trained operators are to perform switching functions within a facility under the direction of the responsible dispatcher or designated person as outlined in the NESC.

A safe grounding design must accomplish two basic functions:

- Ensure that a person in the vicinity of grounded structures and facilities is not exposed to critical levels of step or touch potential.
- Provide a path for electric currents into the earth under normal and fault conditions without exceeding any operating and equipment limits or adversely affecting the continuity of service.

Applicant's equipment ground sources can contribute significant fault current. These ground sources should be considered in the design of the grounding system. The grounding system should be designed to provide a solid ground for all metallic structures and equipment in accordance with the last edition of IEEE Standard 80 IEEE Guide for Safety in AC Substation Grounding. The fence safety clearances in the Applicant's facility shall comply with Section 11 of the latest edition of ANSI C2, National Electrical Safety Code. Testing must be performed to insure safe step and touch potential parameters been met in accordance with IEEE 80.

When various switching devices are opened on an energized circuit, its ground reference may be lost if all sources are not effectively grounded. This situation may cause over voltages that can affect personnel safety and damage equipment. This is especially true when one phase becomes short-circuited to ground. Therefore, the interconnected transmission power system is to be effectively grounded from all sources. Interconnection generators should provide for effective system grounding of the high-side transmission equipment by means of a grounded high-voltage generation step-up transformer.

#### ***Insulation and insulation coordination.***

Insulation coordination is the selection of insulation strength. Insulation coordination must be done properly to ensure electric system reliability and personnel safety. Basic switching surge levels, surge arrester, conductor spacing and gap application, substation and transmission line insulation strength, protection, and shielding shall be documented and submitted for evaluation as part of the interconnection plan. Equipment Basic Impulse Levels (BIL) shielding and surge protection shall be designed to meet the latest IEEE C62 standards, along with DP&L standards. The minimum substation basic impulse levels for DP&L are shown in section R2.1.4. Facilities in areas with significant air pollution may require a higher insulation level. Higher strength insulators are available and should be used if needed to meet bus momentary fault circuit withstand values.

#### ***Voltage, Reactive Power, and power factor control.***

PJM is responsible for the stability and reliable operation of the electric transmission system. An essential part of the transmission system reliability is the coordination of real and reactive power sources to maintain an adequate voltage profile both for normal and contingency conditions. Reactive sources must be distributed throughout the electric systems due to large voltage drops associated with transmission of reactive power. Operators of transmission systems follow voltage control strategies to minimize the risk of exceeding equipment voltage limitations and the grid's voltage stability limitations.

*Generation Interconnection* – All generation customers interconnected to the DP&L transmission system are responsible for operating their units in a stable manner. Generation excitation and prime mover controls are key elements in ensuing electric

system stability and reliability. Reasonable measures should be taken to avoid tripping of the generation facilities due to high or low voltage excursions. PJM must have the ability to establish voltage and governor control requirement for all generators connected to the system. These requirements may vary depending on location, size, and type of generation installed. Generation customers are required with oversight by PJM to follow the current NERC and RF standards and guides for generation operation, protection, and control. Power factor requirements for new generation interconnection requests and increases to existing generators are documented in PJM Manual 14A – Generation and Transmission Interconnection Process in the section for Additional Generation Requirements. Specific requirements for voltage regulators, power system stabilizers, governor controls, and remote control and telemetry of such devices will be determined during the System Impact Study. The specific requirements for a generator will become part of the Interconnection Service Agreement.

*Transmission Facilities* – The transmission system must be capable of moving electric power under a wide variety of expected system conditions. Reasonable measures should be taken to avoid tripping of transmission facilities due to high or low voltage excursions. Transmission facilities must be designed to minimize excessively high voltages during light transmission loading conditions, yet have adequate reactive supplies to support system voltage during heavy transmission loading conditions.

*End-User* –End-Users connected directly to the DP&L transmission system should plan and design their systems to operate at close to unity power factor to minimize the reactive power burden on the transmission system.

***Power quality impacts.***

The Applicant shall take responsibility for limiting harmonic voltage and current distortion and/or voltage flicker caused by their equipment. Limits for harmonic distortion (including inductive telephone influence factors) are consistent with those published in the latest ANSI/IEEE 519, Recommended Practices and Requirements for Harmonic Control in Electrical Power Systems. DP&L criteria requires that flicker occurring at the Interconnection Point shall be compatible with the levels specified in IEC 61000-3-7, “Assessment of emissions limits for fluctuating loads in MV and HV power systems.” Compatibility levels are shown below.

Voltage Levels	Pst (Perception, Short Term)	Plt (Perception, Long Term)
≤ 1 kV	1.0	0.8
1kV < V ≤ 35kV	0.9	0.7
> 35kV	0.8	0.6

Depending upon the nature of the equipment and its location, DP&L may require the installation of a monitoring system to permit ongoing assessment of compliance with these criteria. The monitoring system, if required, will be installed at the Applicant’s expense.

Certain electrical equipment in the Applicant’s facility may be sensitive to normally occurring electric interference from nearby connected loads within the facility, from other End-Users connected to the power system, from natural causes, and system switching, etc. If sensitive electrical equipment is to be supplied directly from the electric power system, it is recommended that the equipment grounding requirements and power supply requirements be examined by the End-User consultant prior to installation. Attention should be given to equipment tolerance to various forms of electric interference, including voltage sags and surges, momentary outages, transients, current and voltage harmonic distortion, or other electrical and electromechanical noise. When electrical disturbances to sensitive electrical equipment such as computers, electronics, controls, and communication equipment cannot be tolerated, the End-User shall install additional equipment as necessary to prevent equipment malfunctions and protect against equipment failure. The End-User should consult the supplier of such sensitive electrical equipment regarding the power supply requirements or the remedial measures to be taken to alleviate potential operational problems or failure of the equipment. The End-User may need to hire a power quality consultant to perform a site survey of the electric power supply environment and furnish recommendations to provide the acceptable levels of reliability and quality of service.

***Equipment Ratings.***

All circuit breakers and other fault-interrupting devices shall be capable of safely interrupting fault currents for any fault they may be required to interrupt. Application of circuit breakers shall be in accordance with the ANSI/IEEE C37 collection of standards.

All current carrying equipment and devices shall be designed to not limit the rating of the transmission line to less than the rating of the transmission circuit without the interconnection. Loads exceeding nameplate or normal design capacities are acceptable only when allowed by manufacturers’ design documentation or standard industry practice.

Equipment BILs, shielding, and surge protective device application must meet requirements as determined by the latest IEEE C62 standards. DP&L will provide the BIL for the system in the interconnection area. Also, equipment must meet all applicable ANSI/IEEE standards and specifications communicated by communicated by PJM and DP&L.

***Synchronization of Facilities.***

Synchronizing equipment consisting of potential transformers and associated protective relaying/controls is required on facilities where energy can be sourced on both sides of an interconnection breaker. This equipment serves the following purposes:

- Verifies the voltages on both sides of a circuit breaker fall within certain tolerances of magnitude and phase angle as established by system conditions.
- Supervises the closing and automatic reclosing of the circuit breaker.
- Prevents the closing of the circuit breaker when the two systems are out of sync.

Generation facilities and transmission facilities customers shall install sync check breakers and relaying on the interconnection breakers with DP&L's transmission system. End-Users do not require sync check breakers as long as they do not have generation on their side of the interconnection. The Applicant assumes all responsibility for properly synchronizing their generation or transmission facilities with the DP&L Transmission System. Upon loss of the DP&L supply, the Applicant shall immediately and positively cause the generation and transmission facilities to be separated from the DP&L system. Synchronizing and connection to the DP&L Transmission System must be performed under the direction of the PJM Control Center with coordination by the DP&L Transmission Control Center.

***Maintenance coordination.***

The maintenance of facilities is the responsibility of the owner of those facilities. Adjoining facilities on the interconnected power system are to be maintained in accordance with accepted industry practices and procedures to ensure proper operation of equipment. Each party is to have a documented maintenance program ensuring compliance to NERC, RF, and PJM standards. DP&L will have the right to review maintenance reports and calibration records of equipment that could impact the DP&L system. Planned maintenance and testing of the facilities must be scheduled and coordinated through PJM to ensure the reliability and capability of the DP&L transmission system is maintained.

***Operational issues (abnormal frequency and voltages).***

The interconnection will be operated consistent with NERC, RF, and PJM requirements. Specific transmission conditions and procedures for operation of Transmission Facilities within PJM are found in PJM Manual 3 – Transmission Operations. All switching that could impact the transmission system must be coordinated through PJM.

The DP&L system typically operates at a nominal 60 Hz with a variation of +0.05 Hz to –0.05 Hz (59.95 to 60.05 Hz). Under certain emergency conditions, the transmission system may operate for a period of time outside of this range. The transmission system is designed to automatically activate a load-shed program as required by RF in the event of an under-frequency system disturbance. The interconnected party is responsible for providing any frequency sensing equipment required to protect their facility during abnormal frequency operation. Generators must be capable of continuous, non-

interrupted operation in this frequency range. Limited time, non-interrupted operation is also expected outside this frequency range in accordance with RF requirements.

Voltages can range on the DP&L transmission system from 90% to 105% of the nominal transmission voltages, which are 345kV, 138kV, and 69kV. Generation facilities and Transmission facilities must be capable of continuous non-interrupted operation within a steady-state voltage range during system normal and single facility outage conditions. During emergency and/or transient system conditions, voltages may temporarily be outside the 90% to 105% range. The End-Users must recognize the potential voltage ranges on the transmission system and install their own voltage regulating equipment if they need a more restrictive voltage range for their equipment. The End-User also must recognize there will be temporary excursions outside the typical voltage range and is responsible for providing any voltage sensing equipment required to protect their equipment during abnormal voltage operation.

***Inspection requirements for existing or new Facilities.***

Each party to the interconnection agreement shall perform routine inspections and testing of its facilities and equipment in accordance with good utility practice and regulatory requirements to ensure the continued interconnection of the facilities with the DP&L transmission system.

Each party shall, at its own expense, have the right to observe the testing of any of the other party's facilities and equipment whose performance may reasonably be expected to affect the reliability of the observing parties' facilities and equipment. Each party shall notify the other party in advance of facility and equipment testing, and the other party may have a representative attend and be present during such testing. If a party observes any deficiencies or defects on or become aware of a lack of scheduled maintenance and testing with respect to the other party's facilities and equipment that might reasonably be expected to adversely affect the observing party's facilities and equipment, the observing party shall provide notice to the other party that is prompt under the circumstances, and the other party shall make any corrections required in accordance with good utility practice and as required by regulatory agencies. Where deficiencies or defects are not resolved in a reasonable manner, decisions will be made on a case by case basis whether the facility may remain in operation. Decisions will consider severity of the deficiency or defect and the resulting impact to reliability.

PJM and DP&L shall receive final documentation of the Facility once the facility is ready for operation. Prior to operation of a facility, the Applicant shall supply to DP&L three copies of all-final electric one-line, equipment data, and schematic diagrams. Subsequent revisions affecting the Facility shall be documented with three copies of the revised electric one-line and schematic diagrams.

The construction, testing, and maintenance of the protective relaying equipment provided by the Applicant for protection of the Transmission System shall be subject to review and approval by DP&L. Prior to the connection, energizing of, or operation of the Facility, the Applicant shall obtain approval from DP&L for the Facility, electrical equipment specifications, and operating procedures. PJM and DP&L will issue final approval for operation of an Applicant's Facilities. For generators and transmission interconnections, a signed Interconnection Agreement with DP&L is required for final approval of the Interconnection and before connection of the Facility to the Transmission System. Failure to meet any of the requirements stated herein to the satisfaction of DP&L may result in a refusal to permit operation of the generation facility. Review and approval by DP&L of



the proposed generation facility specifications and plans shall not be construed as confirming or endorsing the design or warranting the safety, durability, reliability, adequacy, or otherwise of the Applicant's Facility.

***Communications and procedures during normal and emergency operating conditions.***

Complete, precise, and timely communication is an essential element for maintaining reliability and security of a power system. Under normal operating conditions, the major link of communication with various interconnects shall be by telephone lines. DP&L and the Interconnected Customer shall maintain communications which shall include, but not limited to:

- System paralleling or separation
- Scheduled or unscheduled shutdowns
- Equipment clearances
- Periodic load reports
- Maintenance schedules
- Tagging of interconnection interrupting devices
- Meter tests
- Relay tests
- Billing
- Other routine communication

In case of emergency or abnormal operating conditions, various communication channels may be used depending on the interconnection category. Emergency telephone numbers should be agreed upon by both parties prior to the actual connect date. The Interconnect Customer shall install and maintain satisfactory operating communications with PJM's system dispatcher and with DP&L's transmission system dispatcher. The Interconnect Customer shall provide standard voice line, dedicated voice line and facsimile communications at its Customer Facility control room through the use of the public telephone system. The interconnection Customer also shall provide and maintain backup communication links with both PJM and DP&L for use during abnormal conditions as specified by PJM and DP&L. The Interconnection Customer further shall provide the dedicated data circuits necessary to provide Interconnection Customer data to PJM and DP&L as necessary to conform with applicable technical requirements and standards.

The Interconnect Customer is required to notify PJM and DP&L their intention to perform any operational step(s) that could have an influence on the transmission system. Planned outages of facilities that impact the transmission system must be scheduled and coordinated through PJM.

Each Interconnect Party shall notify the other parties promptly when it becomes aware of an emergency condition that may reasonably be expected to affect operation of the Customer Facility, the Customer Interconnection Facilities, the DP&L Interconnection Facilities, or the transmission system. The Interconnection Customer is required to follow PJM and DP&L instructions during emergency conditions. Specific instructions may also be given regarding the operation of the Applicant's Facilities depending on the nature of the emergency. These instructions may consist of voltage schedule changes, real and/or reactive dispatch changes, or instructions to shut down or start-up the Applicant's generation. It is the Applicant's responsibility to ensure that the unit operators follow all instructions given by PJM or DP&L during system emergencies. Participation in drills

conducted by PJM or DP&L is required upon request. DP&L personnel must be granted 24x7 access for emergency patrol or tagging purposes.

End-user customers will provide communication to DP&L through their DP&L Account Managers.

## **New Load and Generation Configuration**

For new load and generation connecting to the DP&L transmission system, exhibits 1-4 have been established as a standard for various interconnection scenarios. The exhibits will provide additional details and requirements specific to typical configurations required by DP&L for new transmission system interconnections.

### Exhibit 1 New Load Connections to DP&L Transmission System Radial Supply Connections to an Existing Transmission Line

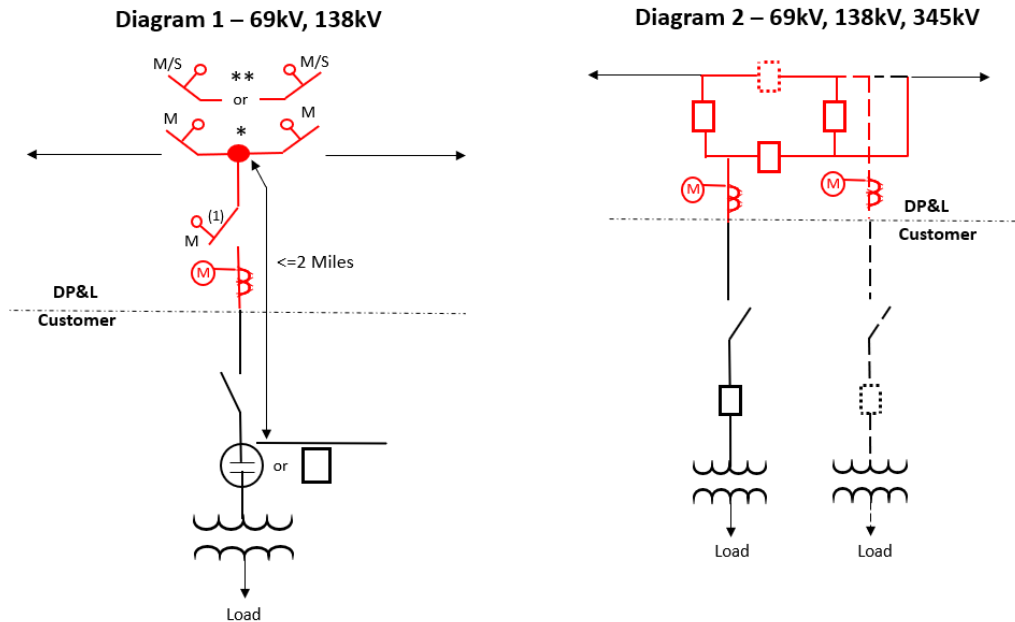

#### Notes:

- \* The installation of air break switches are only permissible on the 138kV and below system for radial line exposure of 2 miles or less. A circuit breaker configuration (example outlined in Diagram 2) will be required for line exposure greater than 2 miles. The switch (1) towards the customer may not be required for short taps (generally 3 spans or less) at the discretion of DP&L.
- \*\*The installation of a circuit breaker(s), similar to Diagram 2, may be necessary for lines with existing sectionalizing equipment and/or system performance needs (number of outages, line exposure, load, number of customers, etc.). The location of the circuit breakers and/or sectionalizing switches will be optimized at locations on the line most advantageous for overall system performance.
- Diagram 1: 1) DP&L may require the customer to install a wave trap to avoid degradation of the PLC signal and 2) Depending on the impact of the tapped facilities on DP&L's high-speed line protection, DP&L may also require the installation of CT's, PT's and relays to interface with DP&L's communication-assisted line protection scheme.
- Diagram 1: High-side fuse protection may be permitted on 69kV and below systems for transformers with nameplates below 10MVA.
- Diagram 2: Communication-assisted trip scheme on the line, either DCB over power line carrier or POTT/differential over fiber/OPGW, is required.
- Diagram 2: Ring bus configurations may be converted to a breaker and a half design at 5 elements and beyond or earlier depending on the size of the generator/load.
- Diagram 1 & 2: The final breaker and/or switch configuration will be determined by DP&L based on site specific engineering layouts, future site plans, configurations, and customer requirements.

## Exhibit 2 New Load Connections to DP&L Transmission System Looped Supply Connections to an Existing Transmission Line

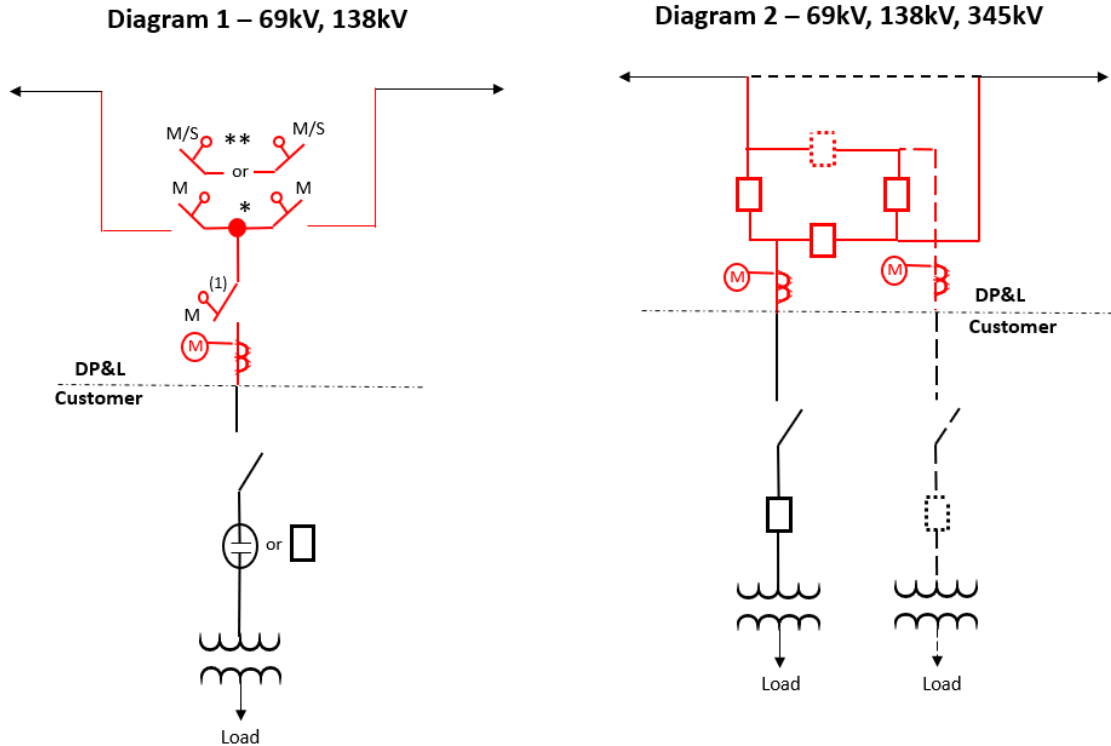

**Notes:**

1. \* The installation of air break switches are only permissible on the 138kV and below system for radial line exposure of 2 miles or less. A circuit breaker configuration (example outlined in Diagram 2) will be required for line exposure greater than 2 miles. The switch (1) towards the customer may not be required for short taps (generally 3 spans or less) at the discretion of DP&L.
2. \*\*The installation of a circuit breaker(s), similar to Diagram 2, may be necessary for lines with existing sectionalizing equipment and/or system performance needs (number of outages, line exposure, load, number of customers, etc.). The location of the circuit breakers and/or sectionalizing switches will be optimized at locations on the line most advantageous for overall system performance.
3. Diagram 1: 1) DP&L may require the customer to install a wave trap to avoid degradation of the PLC signal and 2) Depending on the impact of the tapped facilities on DP&L's high-speed line protection, DP&L may also require the installation of CT's, PT's and relays to interface with DP&L's communication-assisted line protection scheme.
4. Diagram 1: High-side fuse protection may be permitted on 69kV and below systems for transformers with nameplates below 10MVA.
5. Diagram 2: Communication-assisted trip scheme on the line, either DCB over power line carrier or POTT/differential over fiber/OPGW, is required.
6. Diagram 2: Ring bus configurations may be converted to a breaker and a half design at 5 elements and beyond or earlier depending on the size of the generator/load.
7. Diagram 1 & 2: The final breaker and/or switch configuration will be determined by DP&L based on site specific engineering layouts, future site plans, configurations, and customer requirements.
8. Diagram 1 & 2: The final breaker and/or switch configuration will be determined by DP&L based on site specific engineering layouts, future site plans, configurations, and customer requirements.

**Exhibit 3  
New Generation Connections to DP&L Transmission System**

Connections to an Existing Transmission Line

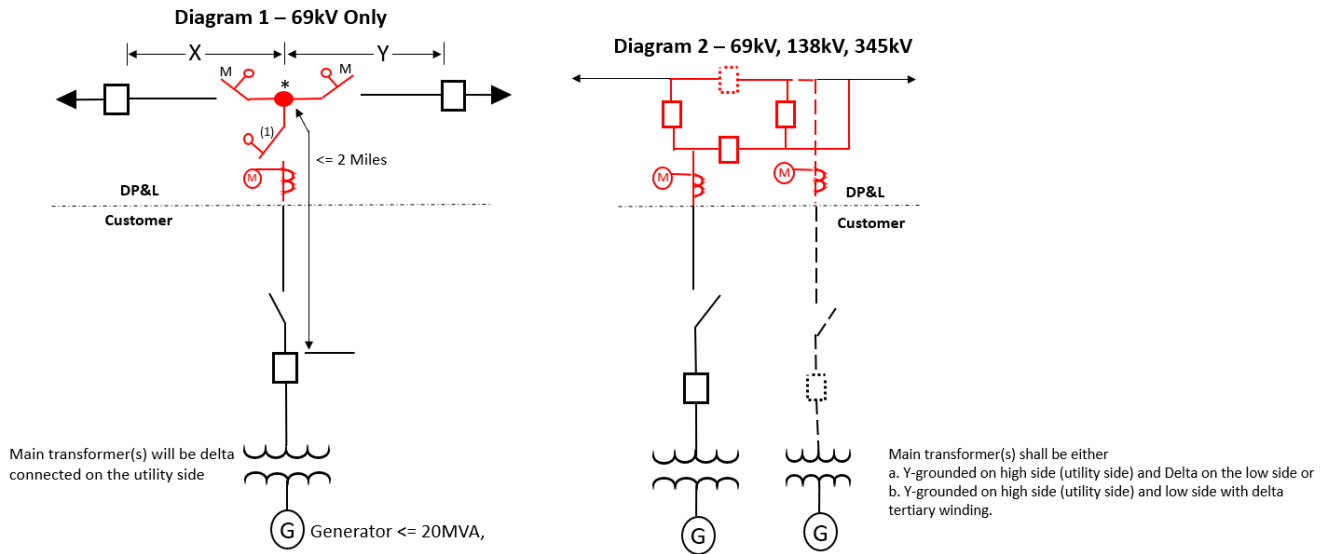

**Notes:**

1. \* The installation of air break switches are only permissible on the 69kV and below system for: existing lines with no existing tapped substations or existing generators. Also, the radial tap distance must be less than or equal to 2 miles and be shorter than branch X and branch Y.
2. Diagram 1: Customer must be able to tie into the existing communication-assisted trip scheme on the line, either DCB over power line carrier or POTT/differential over fiber/OPGW.
3. Diagram 2: Communication-assisted trip scheme on the line, either DCB over power line carrier or POTT/differential over fiber/OPGW, is required.
4. Diagram 2: New generation substations located less than 5 miles from an existing substation may be required to expand an existing substation. An example expansion is highlighted in Diagram 2.
5. Diagram 2: Ring bus configurations may be converted to a breaker and a half design at 5 elements and beyond or earlier depending on the size of the generator/load.
6. Diagram 1 & 2: The final breaker and/or switch configuration will be determined by DP&L based on site specific engineering layouts, future site plans, configurations, and customer requirements.

**Exhibit 4**  
**New Generation/Load Connections to DP&L Transmission System**  
Connections to an Existing Substation

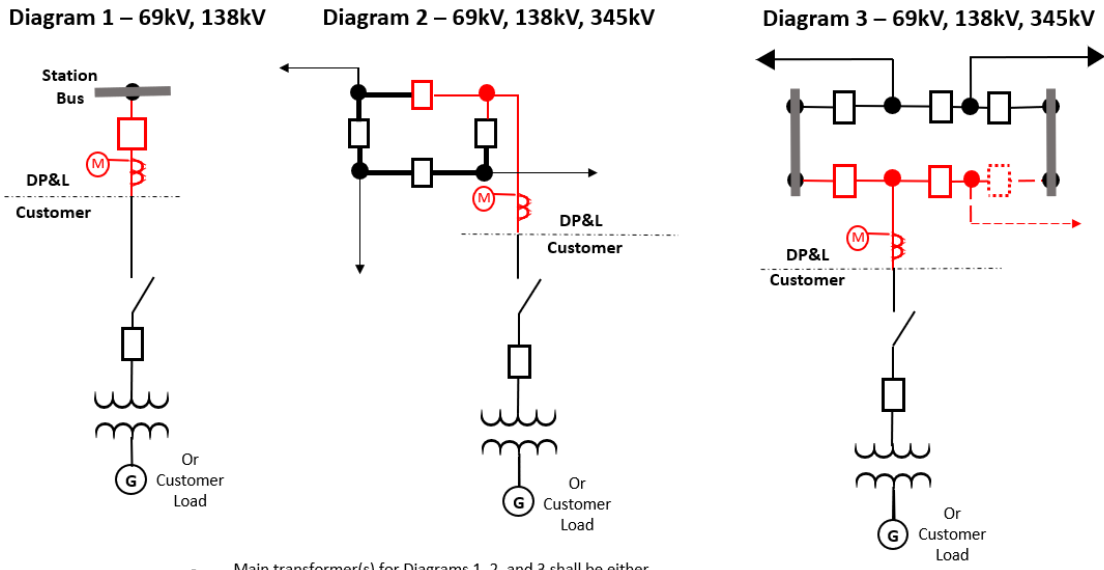

**Notes:**

1. Diagram 1, 2, & 3: Generator/Load Connections into existing substations will require circuit breaker installations. The final breaker configuration will be determined by DP&L based on site specific engineering layouts, future site plans, configurations, and customer requirements.
2. Communication-assisted trip scheme on the line, either DCB over power line carrier or POTT/differential over fiber/OPGW, is required.
3. Diagram 2: Ring bus configurations may be converted to a breaker and a half design at 5 elements and beyond or earlier depending on the size of the generator/load.

## **Definitions**

- **Applicant**  
The party requesting Interconnection to the DP&L system
- **Applicant Interconnection Facilities**  
All the facilities owned by Applicant that are required to provide the Interconnection with DP&L.
- **Circuit Breaker**  
A switching device capable of making, carrying and breaking currents under normal circuit conditions and also making, carrying for a specified time and breaking currents under specified abnormal conditions such as those of a short circuit.
- **Contingency**  
An event, usually involving the loss of one or more elements that affects the power system at least momentarily.
- **Control Area**  
An electric power system or combination of electric power systems bounded by interconnection metering and telemetry to which a common generation control scheme is applied in order to:
  - Match the power output of the generators within the electric power system(s) and energy purchased from entities outside the electric power system(s), with the load within the electric power system(s).
  - Maintain scheduled interchange with other Control Areas, within the limits of Good Utility Practice.
  - Maintain the frequency of the electric power system(s) within reasonable limits in accordance with Good Utility Practice and the criteria of the applicable reliability council of NERC.
  - Provide sufficient generating capacity to maintain operating reserves in accordance with Good Utility Practice.
- **Disconnect Switch**  
A mechanical switching device used for changing the connections in a circuit for isolating a circuit or equipment from a voltage source.
- **DP&L Interconnection Facilities**  
All the facilities owned by DP&L that are required to provide the Interconnection with the Applicant.
- **EMS**  
Energy Management System, a data acquisition and control computer system maintained and used by DP&L to gather real time information regarding the Transmission System and to provide remote control of individual DP&L switching devices and generating units. The EMS also acts as an accounting and detailed calculation platform to refine and store data.
- **FERC**  
The Federal Energy Regulatory Commission
- **Flicker**  
Low frequency voltage fluctuations that can be observed through changes in intensity or color of illumination. Flicker is measured using an IEC flicker meter.
- **Generation**  
The process of producing electrical energy from other forms of energy; also, the amount of electric energy produced, usually expressed in kilowatt-hours (kWh) or megawatt hours (MWh).

- **Generation Owner**

The owner of the generation being interconnected to the DP&L Transmission System
- **Good Utility Practice**

Any of the practices, methods, and acts engaged in or approved by a significant portion of the electric utility industry during the relevant time period, or any of the practices, methods and acts that, in the exercise of reasonable judgment in light of the facts known at the time the decision is made, could have been expected to accomplish the desired result at a reasonable cost consistent with good business practices, reliability, safety and expedition. Good Utility Practice is not intended to be limited to the optimum practice, method, or act to the exclusion of all others, but rather is intended to include acceptable practices, methods, or acts generally accepted in the region.
- **Harmonics**

An integer multiple of the actual system frequency, which is 60 Hz for the United States.
- **Interconnection**

Physical connection of the applicant's facilities to DP&L's facilities for the purpose of electric power transfer.
- **Interconnection Agreement**

An agreement that documents the physical interconnection between the Applicant and DP&L, and defines the continuing responsibilities and obligations of the Applicant and DP&L during the term of the agreement.
- **Interconnection Facilities**

The facilities of all parties that make up the Interconnection Point.
- **Interconnection Point**

The point where the Applicant Interconnection Facilities are physically connected to the DP&L Interconnection Facilities.
- **Metering Point**

The point at which the amount of Generation delivered to the Transmission System is measured, or the amount of load delivered to the customer or the amount of power exchanged between DP&L and another transmission entity.
- **NERC**

The North American Electric Reliability Corporation
- **OATT**

The Open Access Transmission Tariff as filed with FERC.
- **PJM**

PJM Interconnection, which is a regional transmission organization (RTO) that coordinates the movement of wholesale electricity in all or parts of 13 states and the District of Columbia.
- **Protective Relay**

A device whose function is to detect defective lines, apparatus, or other power system conditions of an abnormal nature and to initiate appropriate control circuit action.
- **RF**

ReliabilityFirst Corporation, a not-for-profit company whose goal is to preserve and enhance electric service reliability and security for the interconnected electric systems within its territory. It is the successor organization to three former Regional Reliability Councils: the Mid-American Area Council, the East Central Area Coordination Council Agreement, and the Mid-American Interconnection



Network organizations. RF is one of the eight regional reliability organizations in North America.

- **SCADA**  
Supervisory Control and Data Acquisition - A system of remote control and telemetry used to monitor and control the electric system.
- **Substation**  
A facility for switching electrical elements, transforming voltage, regulating power, or metering.
- **Transmission System**  
The transmission facilities owned, operated or controlled by DP&L, including conductors, circuit breakers, switches, transformers and other associated equipment used to control the transfer of energy from one place to another, and shall include any modifications, additions, or upgrades made to those facilities.

## **REVISION HISTORY**

Revision	Date	Comments
1	07/31/01	Initial version of report
2	08/31/05	Review and Minor modifications – PJM as Transmission Operator for 345kV
3	04/13/09	Reformatted, revised to reflect PJM as the transmission Provider, Transmission Authority, and Transmission Planner, added definitions section, and reference to NERC requirements.
4	08/12/09	Revisions to incorporate RF audit recommendations.
5	05/13/10	Minor revisions to clarify end user process and to list actual DP&L transmission voltages available.
6	05/31/11	Annual Review – no changes made.
7	02/28/12	Annual Review – Complete re-write to organize with headings corresponding to the requirements specified in NERC Standard FAC-001-0. Clarify the DPL/PJM relationship and responsibilities.
8	03/20/13	Annual Review – Minor revision to clarify responsibilities for jointly owned facilities.
9	11/25/13	Annual Review – Minor modifications to headings to match the NERC Standard FAC-001-1 version.
10	8/8/14	Annual Review – Minor modifications to headers and labels
11	11/30/15	Annual Review – the new standard (FAC-001-2) moved old R3 sub-requirements to the Guidelines section and dissolved old R4 into new R1/R3. The prescriptive content of this document remained unchanged.

		Modifications were made to headers and labels to remove correlation to the old sub-requirements.
12	11/29/16	Annual Review – no changes made.
13	11/3/17	Annual Review – disclaimer added at end of Introduction giving PJM documentation precedence if conflict exists.
14	11/26/18	Annual Review – added language to adhere to FAC-001-3 R3.3 requirements and added standardized interconnection layouts.
15	12/11/19	Annual Review – Revised standardized interconnection layouts.