

Transmission ITP

Ops Parameters

PJM State & Member Training Dept.

Students will be able to:

- Define the purpose of:
 - Thermal, voltage and stability limits
 - System Operating Limits (SOLs)
 - Interconnection Reliability Operating Limits (IROLs)
- Define PJM's thermal operating criteria
- State the consequence of violating thermal limits
- State the actions to control violations of thermal limits

- Describe how IROLs are determined and monitored in PJM
- Identify the IROLs in the PJM footprint
- Define PJM's voltage operating criteria
- State the consequences of violating voltage limits
- State the actions to control violations of voltage limits
- Identify PJM's voltage schedule guidelines
- Describe the effects of capacitors & reactors on voltage levels on the BES

- Identify which reactive resources can be switched without instruction from PJM
- Describe the effects of LTCs & PARs on the voltage profile of the BES
- Identify the requirements to submit information for outages of reactive resources
- Describe the purpose of the reactive testing program

Purpose of Limits

Definitions

- Thermal Limit/Rating
 - A boundary on the current carrying capability of equipment to prevent operation at excessive temperatures
 - A thermal restriction is placed on every piece of equipment that carries current
 - Most commonly stated in MVA but also could be in Amps
 - Varies with
 - Temperature (16 temperature sets; 8 day and 8 night)
 - Wind speed (Ratings calculated at fixed wind speed)
 - Daylight intensity (Day vs Night ratings)
 - Equipment (Various limitations on equipment)
 - Time of applied current
(Normal, Long/Short-Term Emergency, Load Dump)

Determination of Thermal Limits/Ratings

- Current - Carrying Capability
 - Depends on ability to dissipate heat
 - Current flowing through conductor heats it up
 - Heat is dissipated through I^2R losses in the conductor

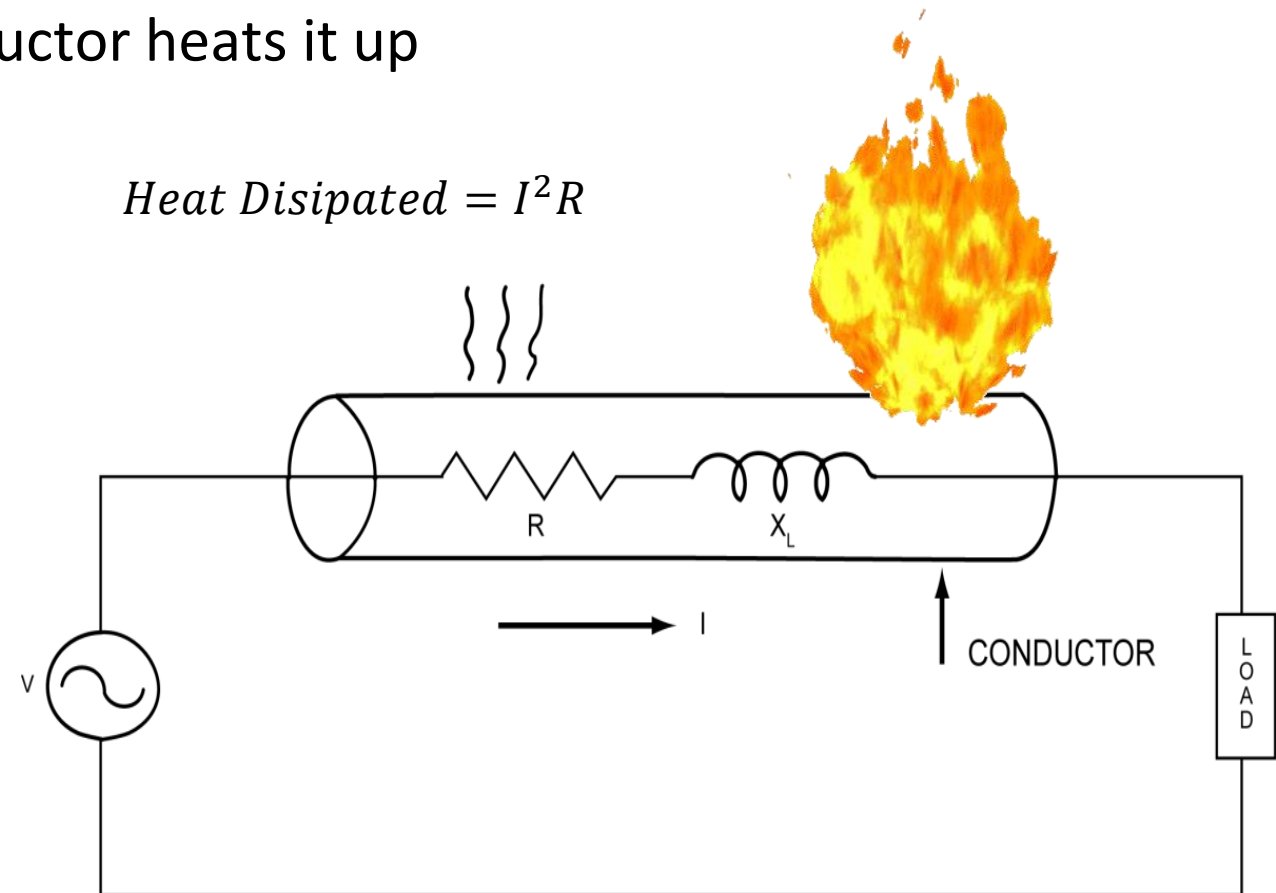

Determination of Thermal Limits/Ratings

- Factors Effecting Ratings

- Season/Ambient Temperature

- How fast can heat from the device be transferred to the air
 - As ambient temperature decreases, heat transfer increases
 - As ambient temperature increases, heat transfer decreases
 - PJM has 16 “Ambient-adjusted” Rating sets with a set of 8 for the night period and a set of 8 for the day period, each with three ratings for each monitored facility

- Time

- As the current increases, it takes less time to incur damage to equipment
 - PJM uses Normal, Long/Short-Term Emergency, Load Dump Rating sets



Determination of Thermal Limits/Ratings

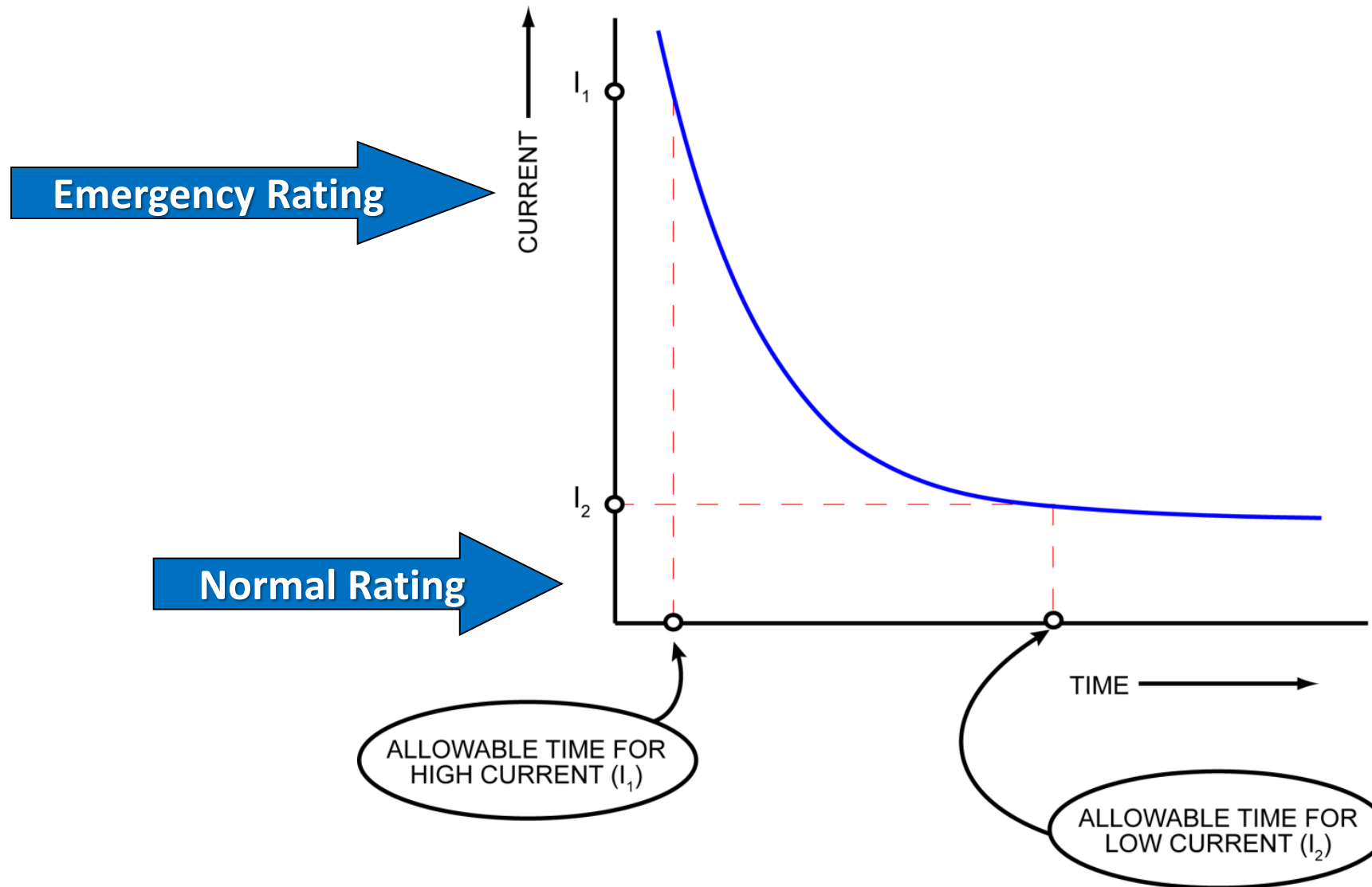

Rating Sets Definition

- All equipment ratings are provided by the owner of the equipment but are based on PJM's rating methodology
 - Normal (Continuous) Rating
 - Equipment can operate at this level for any length of time without incurring damage
 - Emergency Rating (Long-Term – LTE or Short-Term - STE)
 - Used to trigger contingency operation
 - Equipment can be damaged if rating exceeded in real-time
 - Load Dump Rating
 - Aids system operator in identifying speed to correct overload
 - Operation at Load Dump Rating for 15 minutes should not cause line to trip
 - Shed load to return actual flow under Load Dump Rating within 5 minutes

Thermal Limits

- LTE and STE limit are identical in most cases
- Many equipment limitations possible:
 Conductor, CB, CT, Meter, Relay, Clearance, Transformer, Wave Trap, Other

Temperature	Normal Limit	Long-Term Emergency Limit	Short-Term Emergency Limit	Load Dump Limit
95°	2650	3015	3015	3467
86°	2725	3090	3090	3554
77°	2780	3145	3145	3617
68°	2830	3195	3195	3674
59°	2849	3250	3250	3738
50°	2855	3300	3300	3795
41°	2855	3350	3350	3853
32°	2855	3405	3405	3916

Equipment Ratings – Dynamic vs. Static

- As previously stated, the rating for a piece of equipment is determined by how effectively the equipment can dissipate the heat generated within it by the flow of power
- Wind, rain/snow, or significant shade effects may allow equipment to exceed its default rating set for a given temperature, because it dissipate more heat
- By using Dynamic ratings, we can make adjustments to the default ratings set to allow for higher flow on a facility when conditions permit

Equipment Ratings – Dynamic vs. Static

- Additional equipment needs to be installed in the field to:
 - Allow real-time monitoring of the specific conditions occurring on the facility with the dynamic ratings, and
 - Send those readings back to the company (and PJM) EMS to determine the adjusted ratings to be used
- PJM has used Dynamic ratings at selected facilities in the PS area for several years to help reduce congestion costs

Equipment Ratings – Variations Across the Footprint

- PJM uses the actual temperatures in each zone to determine that zone's rating set
- Some zones (i.e. – AEP) have multiple sub-zones because of their size
 - If conditions are such that variations in temperatures are severe across the sub-zones, different rating sets can be used
 - If a line of thunderstorms is crossing the footprint in the summer, it may be cooler behind the storm system
 - The western sub-zone of AEP may be 10 degrees or more cooler than the eastern sub-zones

Equipment Ratings – Variations across the footprint

Mid-Atlantic

Zone	Reference City
PS	Newark, NJ
PE	Philadelphia PA
PL	Allentown, PA
JC	Morristown, NJ
ME	Reading, PA
PN	Erie, PA
PN	Johnstown, PA

Mid-Atlantic/Southern

Zone	Reference City
AE	Atlantic City, NJ
DPL	Dover, DE
BC	Baltimore, MD
PEP	Washington, DC
DOM	Richmond VA
DOM	Mount Storm, WV

APS/ATSI/DUQ

Zone	Reference City
APSNE	State College, PA
APSNW	Wheeling, WV
APSSE	Cumberland, MD
APSSW	Morgantown, WV
FETOL	Toledo, OH
FESPR	Springfield, OH
FEAKR	Akron, OH
DUQ	Pittsburgh, PA

AEP/COMED/DAY/DEOK/EKPC

Zone	Reference City	Zone	Reference City
AEPAB	Abingdon VA	COMED	Chicago, IL
AEPCH	Charleston, WV	DAY	Dayton, OH
AEPCL	Columbus, OH	DEOK	Cincinnati, OH
AEPFW	Fort Wayne, IN	EKPC	Winchester, KY
AEP RN	Roanoke, VA	OVEC	Piketon, OH

Distribution Factors

Introduction to Distribution Factors

- Definition
 - The percentage of flow currently on a line that will transfer to another line as a result of the loss of the first line
- Characteristics of Distribution Factors
 - Determined by line impedances
 - Computer generated
 - Expressed as a decimal number of 1.0 or less
 - Distribution factor for a line for the loss of itself is -1.0 if line flow is positive

Introduction to Distribution Factors

- Characteristics of Distribution Factors (cont.)
 - Can be a positive or negative factor
 - Sum of all distribution factors in a closed system is zero

- Formula:

$$\text{New flow on line} = \text{Previous flow} + [(D_{\text{fax}}) (\text{Flow on outaged facility})]$$

Example Simple Calculations

For the loss of line C:

$$D_{\text{fax}_B} = 0.625$$

$$D_{\text{fax}_C} = -1.0$$

$$D_{\text{fax}_D} = 0.250$$

$$D_{\text{fax}_E} = 0.125$$

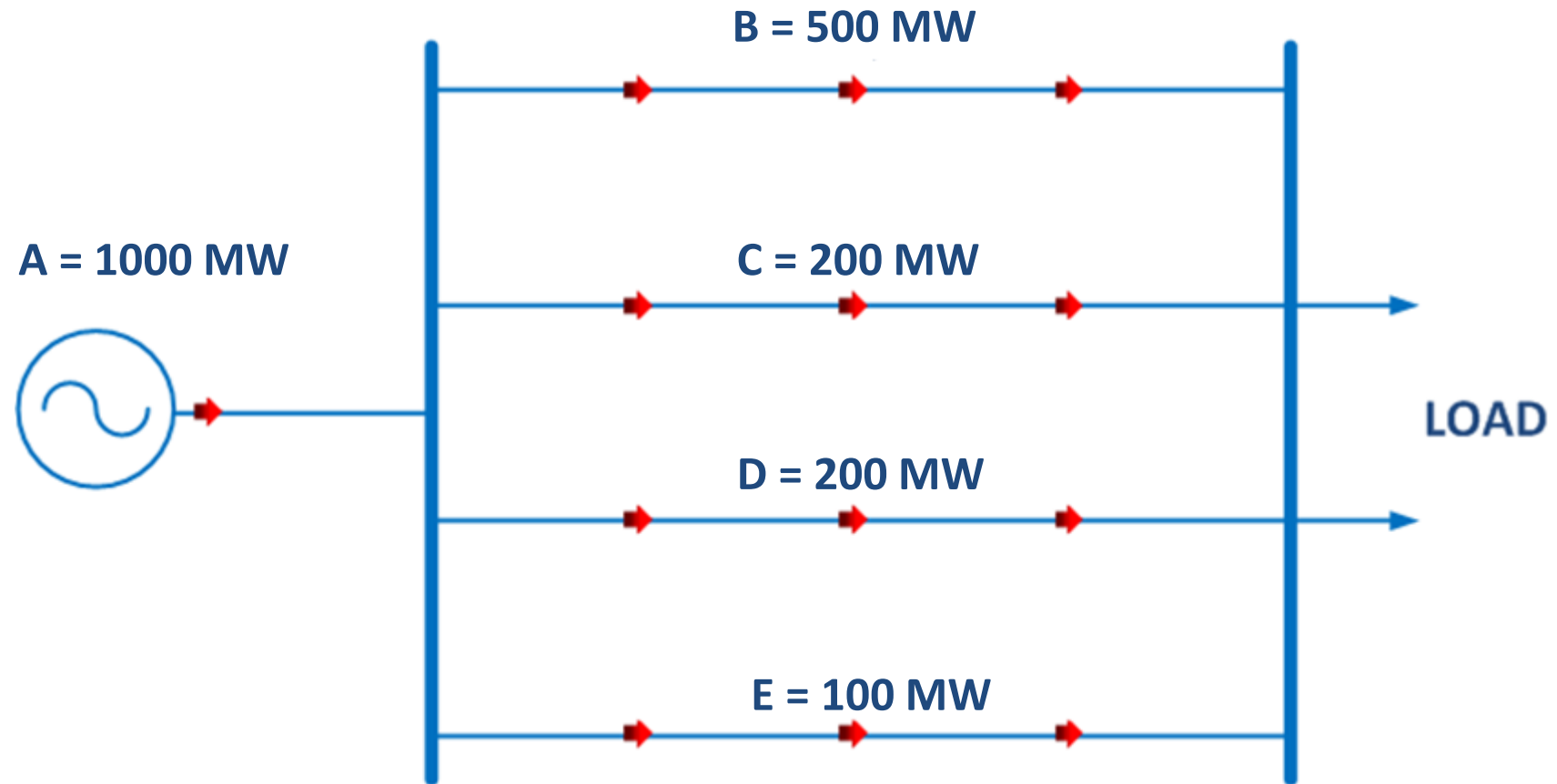

Example Simple Calculations

Line B

$$\begin{aligned} &= 500 \text{ MW} + (0.625)(200 \text{ MW}) \\ &= 500 \text{ MW} + 125 \text{ MW} = 625 \text{ MW} \end{aligned}$$

Line C

$$\begin{aligned} &= 200 \text{ MW} + (-1.0)(200 \text{ MW}) \\ &= 200 \text{ MW} - 200 \text{ MW} = 0 \text{ MW} \end{aligned}$$

Line D

$$\begin{aligned} &= 200 \text{ MW} + (0.25)(200 \text{ MW}) \\ &= 200 \text{ MW} + 50 \text{ MW} = 250 \text{ MW} \end{aligned}$$

Line E

$$\begin{aligned} &= 100 \text{ MW} + (0.125)(200 \text{ MW}) \\ &= 100 \text{ MW} + 25 \text{ MW} = 125 \text{ MW} \end{aligned}$$

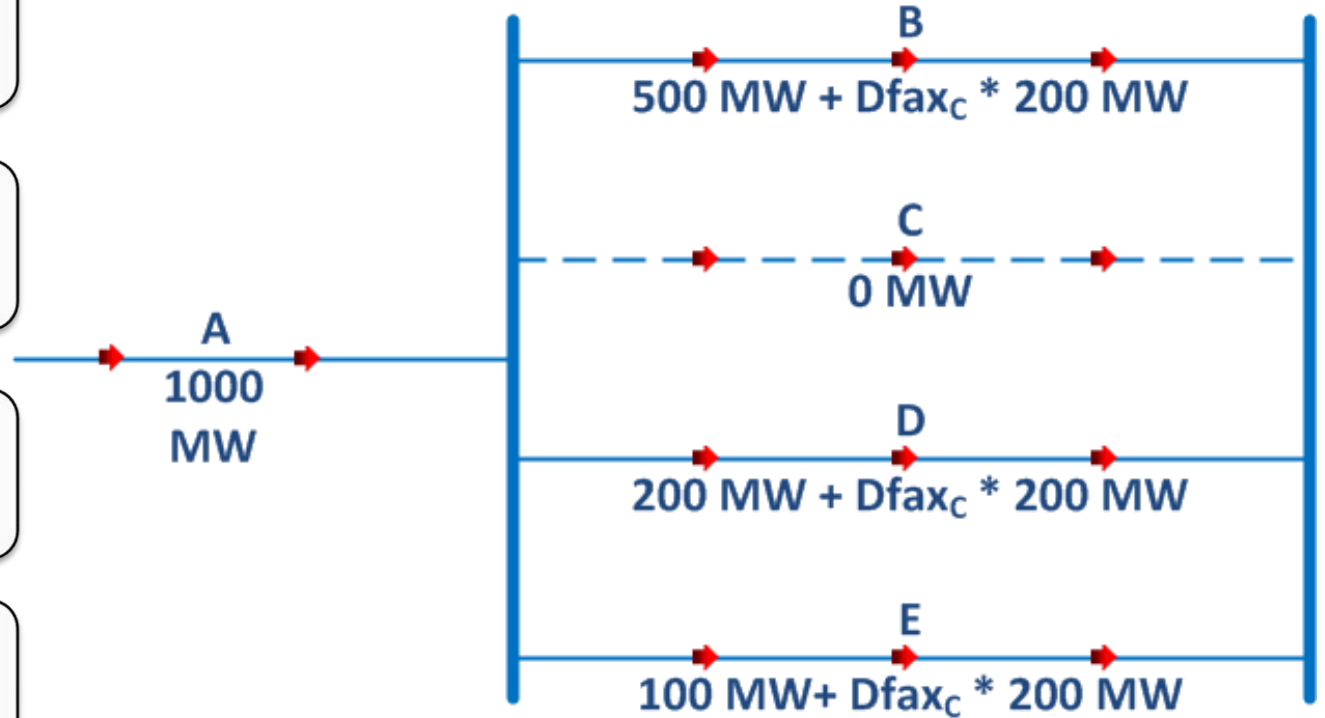

Applications of Distribution Factors

- Line Outages
 - Use distribution factors to estimate how power will flow and predict any flow problems which may result from a line outage
 - Generally performed by computer tool
- Flow Analysis
 - Used to predict the results of losing a specific piece of equipment (Contingency analysis)

Distribution Factor Exercises

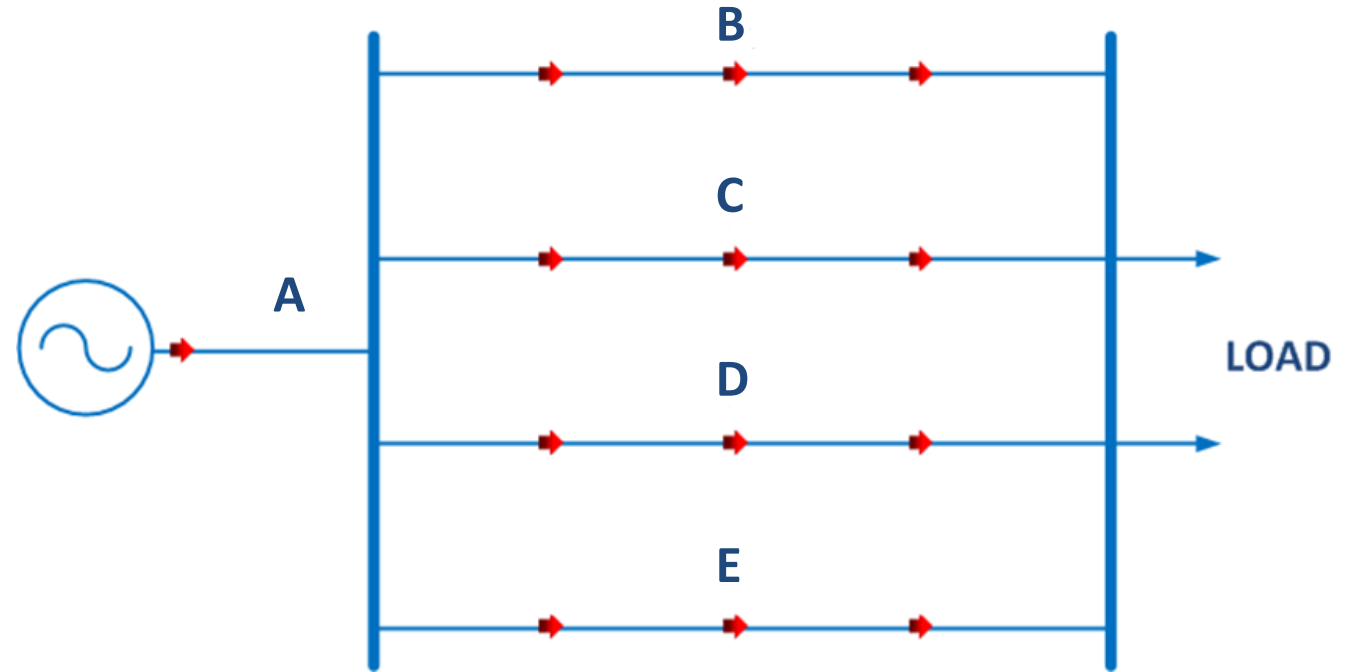

Distribution Factors for Loss of:

	Line B	Line C	Line D	Line E
On B	-1.0	0.625	0.625	0.556
On C	0.4	-1.0	0.25	0.222
On D	0.4	0.25	-1.0	0.222
On E	0.2	0.125	0.125	-1.0

Distribution Factor Exercises

- 1) Calculate the line flows for each line following the loss of line B, if the initial flows were:

Distribution Factor Exercises

- 2) Calculate the line flows for each line following the loss of line D, if the initial flows were:

Generation Shift Factors

Generation Shift Factors

- Similar to Distribution Factors
 - Decimal Fraction
 - Used to analyze the effect of generation shifts on MW flow
 - Does NOT add up to 0
- Definition
 - Change in generation MW output that will appear on a line or facility
 - Used to predict the effect of generation changes on transmission line flow

Generation Shift Factors

- Formula

New flow on line = Previous flow + [(Gen Shift Factor)(Amount of MW Shift)]

Generation Shift Factors

- Line 3 Flow = 500 MW
- Increase Gen A by 100 MW
- What is resultant flow on Line 3?

$$\text{New Flow} = 500 \text{ MW} + (.12)(+100\text{MW}) = 512 \text{ MW}$$

	Line 1 (A-B)	Line 2 (A-B)	Line 3 (A-C)	Line 4 (C-B)	Line 5 (B-D)
Gen A	0.30	0.30	0.12	0.12	0.30
Gen B	-0.20	-0.20	-0.06	-0.06	0.40
Gen C	-0.08	-0.08	-0.60	0.60	-0.15
Gen D	-0.12	-0.12	-0.03	-0.03	-0.50

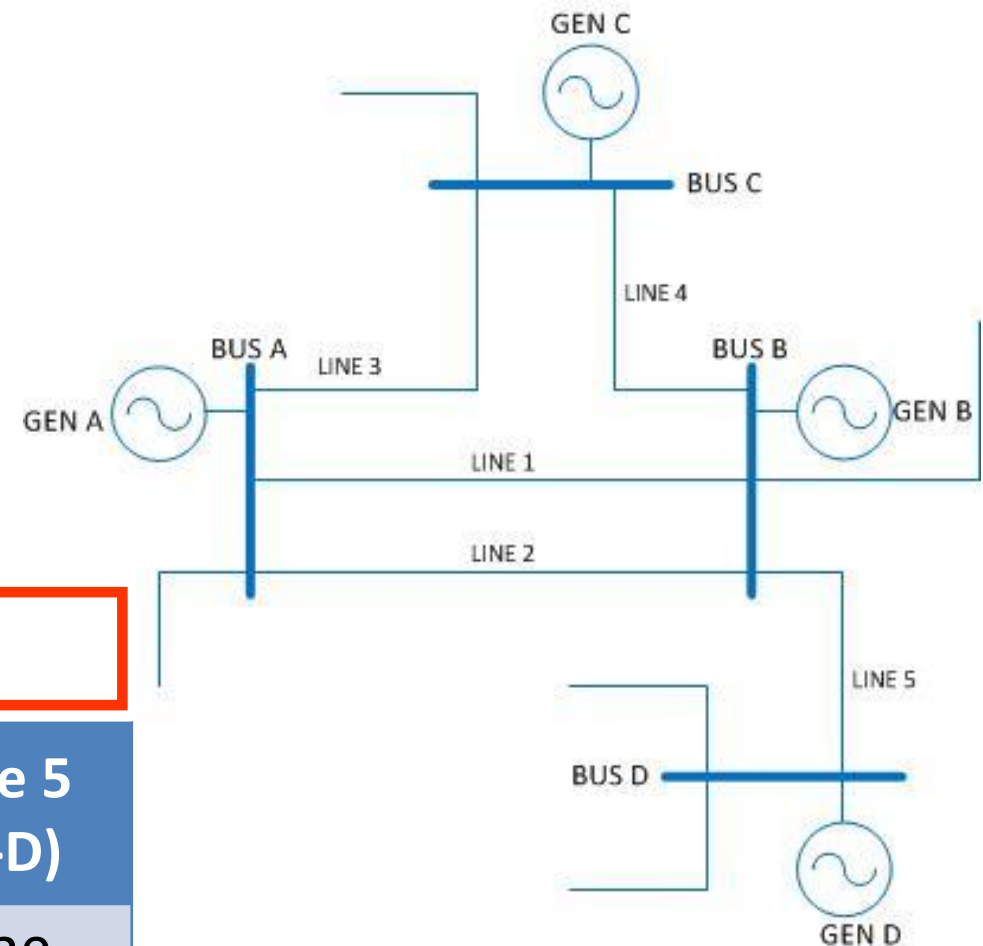

Generation Shift Factors

- Line 3 Flow = 512 MW
- Now, decrease Gen C by 100 MW
- What is resultant flow on Line 3?

$$\text{New Flow} = 512 \text{ MW} + (-0.6)(-100\text{MW}) = 572 \text{ MW}$$

	Line 1 (A-B)	Line 2 (A-B)	Line 3 (A-C)	Line 4 (C-B)	Line 5 (B-D)
Gen A	0.30	0.30	0.12	0.12	0.30
Gen B	-0.20	-0.20	-0.06	-0.06	0.40
Gen C	-0.08	-0.08	-0.60	0.60	-0.15
Gen D	-0.12	-0.12	-0.03	-0.03	-0.50

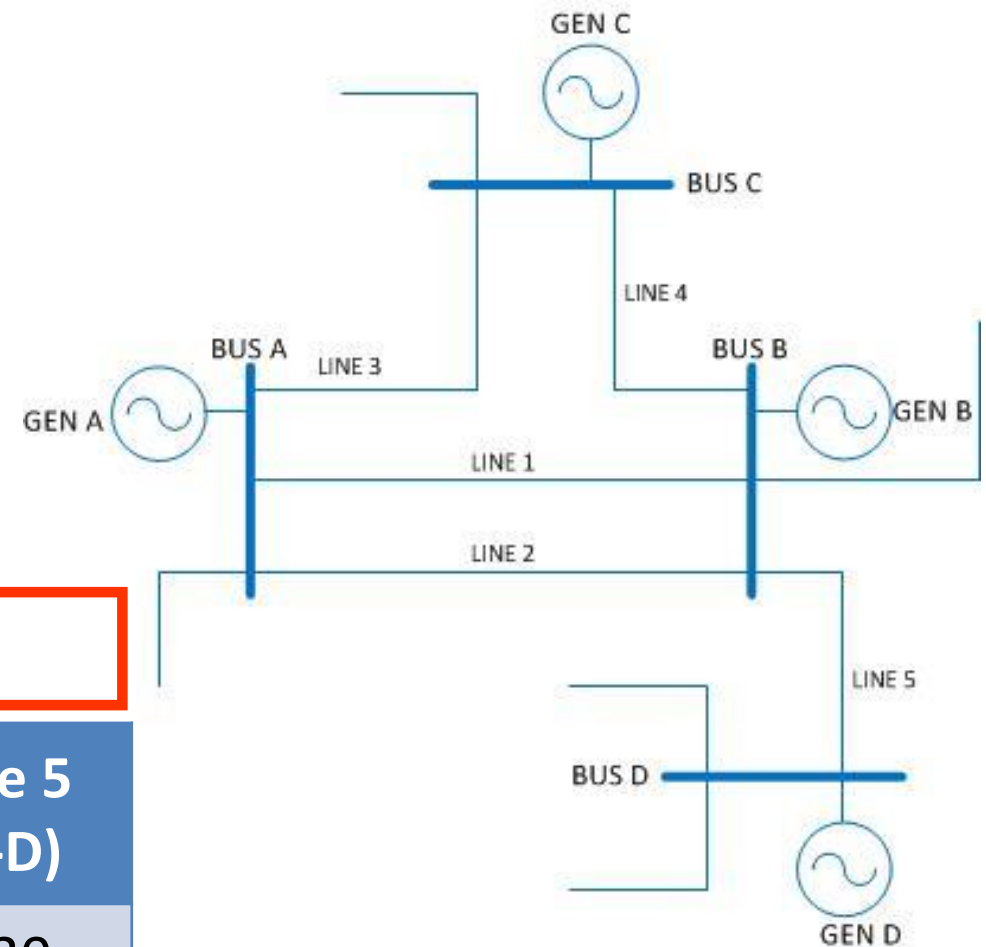

Generation Shift Factors

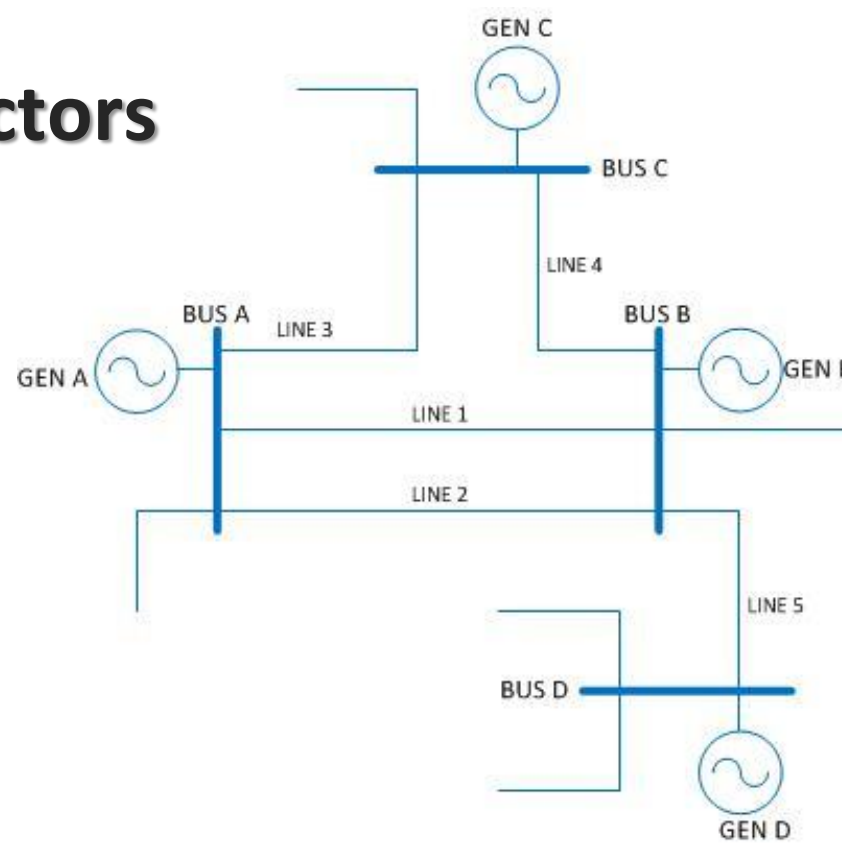

	Line 1 (A-B)	Line 2 (A-B)	Line 3 (A-C)	Line 4 (C-B)	Line 5 (B-D)
Gen A	0.30	0.30	0.12	0.12	0.30
Gen B	-0.20	-0.20	-0.06	-0.06	0.40
Gen C	-0.08	-0.8	-0.60	0.60	0.15
Gen D	-0.12	-0.12	-0.03	-0.03	-0.50

Generation Shift Factors Exercises

	Line 1 (A-B)	Line 2 (A-B)	Line 3 (A-C)	Line 4 (C-B)	Line 5 (B-D)
Gen A	0.30	0.30	0.12	0.12	0.30
Gen B	-0.20	-0.20	-0.06	-0.06	0.40
Gen C	-0.08	-0.8	-0.60	0.60	0.15
Gen D	-0.12	-0.12	-0.03	-0.03	-0.50

- 1) The flow on Line 1 (A-B) is 850 MW. Generator A output is increased by 100 MW. What is the new flow on Line 1 (A-B)?
- 2) Now Generator B decreases output by 100 MW. What is the new flow on Line 1 (A-B)?

\$/MW Effect

- Adjustment of Shift Factors due to Economics

- Definition

– $\$/\text{MW Effect} = (\text{Current Dispatch Rate} - \text{Unit Bid}) / \text{Unit Generator Shift Factor}$

- Unit with lowest $\$/\text{MW}$ effect is redispatched when system is constrained
- Other unit operating constraints taken into account (I.e. min run time, time from bus, etc)
- In an emergency, economics takes the “back seat” to reliability

Types of Limits

Types of Limits

- Thermal Limit/Rating
 - A boundary on the current carrying capability of equipment to prevent operation at excessive temperatures
 - A thermal restriction is placed on every piece of equipment that carries current
- Voltage limit
 - Maintain system reliability
 - High voltage limit protects equipment from damage
 - Low voltage limit protects system from voltage instability and equipment damage

Types of Limits

- Stability Limits
 - Stability is related to the angular separation between points in the system
 - Prevents electrical separation of a generating unit or a portion of the RTO
 - Typical angular separation of the voltages for a high voltage transmission is small, ranging from 5° to 15°
 - When a system is angle unstable, angle differences grow to larger values
 - For example, angle differences may exceed 90°
 - System operators lose control of both MW and MVAR flows in an angle unstable system

Types of Limits

- System Operating Limit (SOL)
 - The value (such as MW, MVAR, Amperes, Frequency or Volts) that satisfies the most limiting operating criteria for a specified system configuration to ensure operation within acceptable reliability criteria
 - Based upon certain operating criteria. These include, but are not limited to:
 - Facility Ratings
 - Transient Stability Ratings
 - Voltage Stability Ratings
 - System Voltage Limits

Types of Limits

- Interconnection Reliability Operating Limit (IROL)
 - A System Operating Limit that, if violated, could lead to instability, uncontrolled separation, or cascading outages that adversely impact the reliability of the Bulk Electric System

PJM Thermal Operating Criteria

PJM Thermal Operating Criteria

- Thermal Operating Criteria
 - Actual Flow less than Normal Rating
 - Contingency Flow less than Long-Term Emergency Rating
 - Operators must be aware when line flows are approaching a limit on both an actual and contingency basis
 - Approaching a system limit
 - Analyze situation
 - Develop game plan
 - Implement plan

PJM Thermal Operating Criteria

- System Operating Limit in PJM
 - All BES facilities and those sub- BES facilities identified as “Reliability and Markets” facilities that are not considered IROL facilities are considered System Operating Limits (SOL)
 - An SOL violation is defined as a non-converged contingency or actual thermal overload violating a limit consistent with the facilities rating duration (i.e. Normal limit = 24 hours, LTE limit = 4 hours)

PJM Thermal Operating Criteria

- Interconnection Reliability Operating Limit in PJM if exceeded, could expose a widespread area of the Bulk Electric System to instability, uncontrolled separation(s) or cascading outages
 - PJM classifies a facility as an IROL facility on the PJM system if wide-area voltage violations occur at transfer levels that are near the Load Dump thermal limit
 - An IROL violation is defined as either flows exceeding the last convergent case transfer limit for 30 minutes or post-contingency simulated flows exceeding the facility load dump limit for 30 minutes

PJM Thermal Operating Criteria

- Interconnection Reliability Operating Limit T_V
 - The maximum time that an IROL can be violated before the risk to the Interconnection or other Reliability Coordinator Area (s) becomes greater than acceptable
 - Each IROLs T_V shall be less than or equal to 30 minutes
 - PJM uses 30 minutes as its T_V for all its IROLs

PJM Thermal Operating Criteria

- Thermal Operating Criteria
 - Control all constraints (actual and contingency) within 30 minutes 100% and within 15 minutes 80% of the time
 - At times, operator may be faced with multiple problems at the same time and have to prioritize the order in which to address them

PJM Thermal Operating Criteria

- Control Prioritization
 - First: Non-Converged Contingency
 - Could be worst problem (voltage collapse) or due to bad data
 - Operator needs to determine cause of non-convergence and take action if problem is real
 - Second: IROL violations
 - Contingency could result in a system collapse
 - Must be controlled within 30 minutes, 100% of time
 - If not, it must be reported to NERC

PJM Thermal Operating Criteria

- Control Prioritization
 - Third: Reactive Transfer Interfaces
 - Many of these are IROL facilities
 - Fourth: Actual Violations
 - Actual flows > Normal limit
 - Prioritize Actual violations based on amount that rating is exceeded and potential system impact
 - Fifth: Contingency Violations
 - Smaller chance of contingency actually occurring
 - If contingency occurs, it becomes actual

PJM Thermal Operating Criteria

Thermal Limit Exceeded	Corrective Actions	Time to correct with Load Shed (Note 1)
Normal Rating (Actual flow greater than Normal Rating but less than Emergency Rating)	Non-cost actions, off-cost actions, emergency procedures except Load Shed Operating Instruction (See M-13, Emerg. Proc.)	Within 15 minutes, load shed is not used
Emergency Rating (Actual flow greater than Emergency Rating but less than Load Dump Rating)	All of the above including Load Shed Operating Instruction to control flow below Emergency Rating	Within 15 minutes (Note 2)
Load Dump Rating (Actual flow greater than Load Dump Rating)	All of the above including Load Shed Operating Instruction to control flow below Emergency Rating	Within 5 minutes (Note 1) (Note 3)

Legend
Non-Cost
Off-Cost
Load Shedding

Note:

1: For unplanned load shed events, TO must initiate load dump action within 5 minutes after PJM issues a Load Shed Directive. TO must not exceed the time based duration of any Emergency rating/Load Dump rating.

2: TOs have the option of providing STE limits that are at least 30 minutes in duration. The STE rating allows the time before load shed to be extended provided the actual flow does not exceed the STE rating. If the actual flow is above the LTE but below STE, load must be shed within the times indicated in Attachment F for the facility, if other corrective actions were not successful.

3: A load shed directive will be issued in an amount sufficient to get below Emergency rating.

Example

If Actual Flow < Normal Rating:

- No corrective actions are required
- No limits are violated

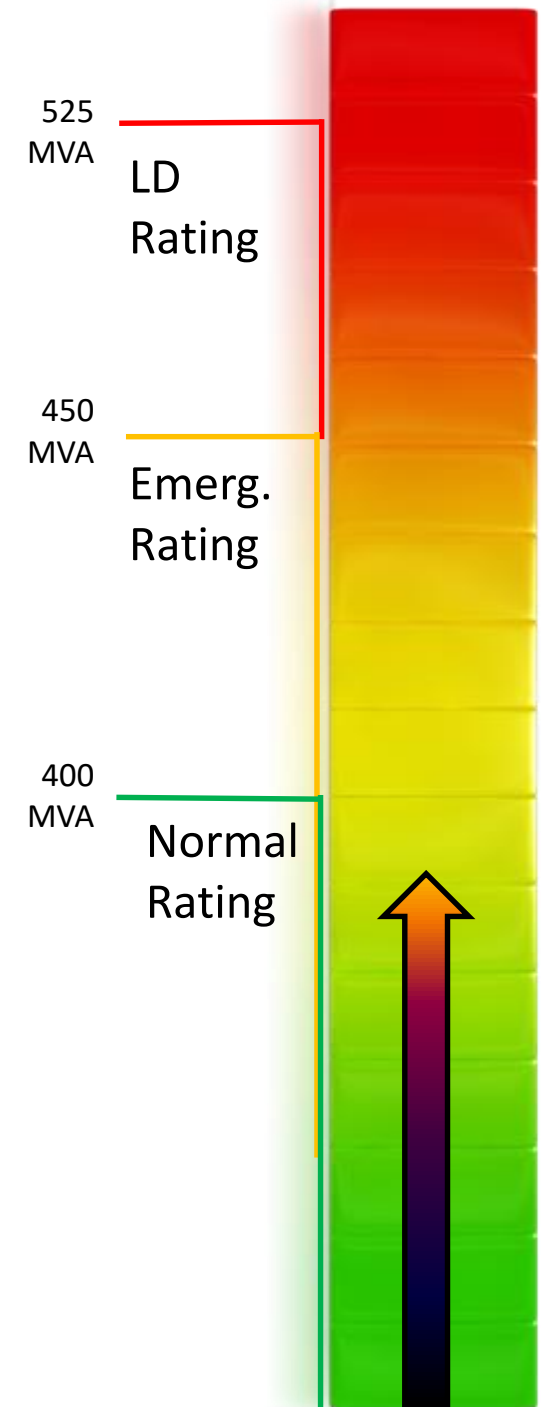

Example

**Actual Flow (430 MVA) is
< LTE but > Normal Rating:**

- Corrective Actions:
 - Non-cost
 - Off-cost options
 - No load shed would be performed
- Goal is to correct problem in:
 - **15 minutes**
 - May not be possible since load shed is not a controlling action

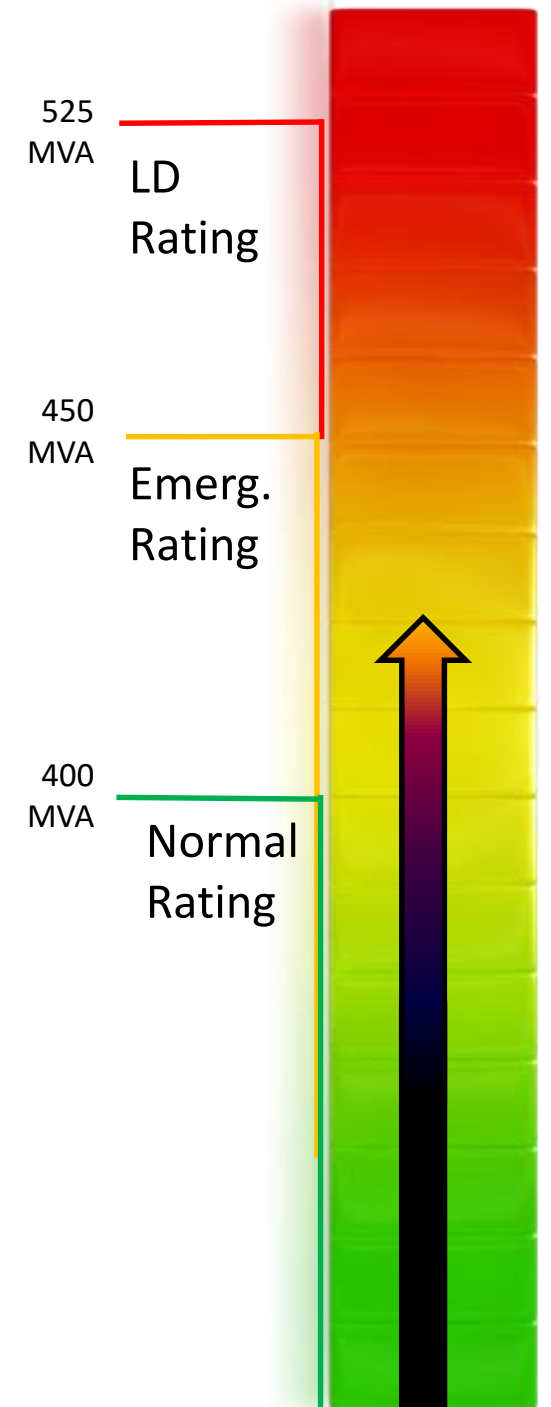

Example

Actual Flow (520 MVA) is $>$ LTE but $<$ LD:

- Corrective Actions:
 - Non-cost
 - Off-cost
 - Load shed options
- Load shed performed to return Actual flow below:
 - LTE rating: **Within 15 minutes**
- Relief needed?
 - 70 MVA
 - May require more than 70 MVA of load shed based on Dfax

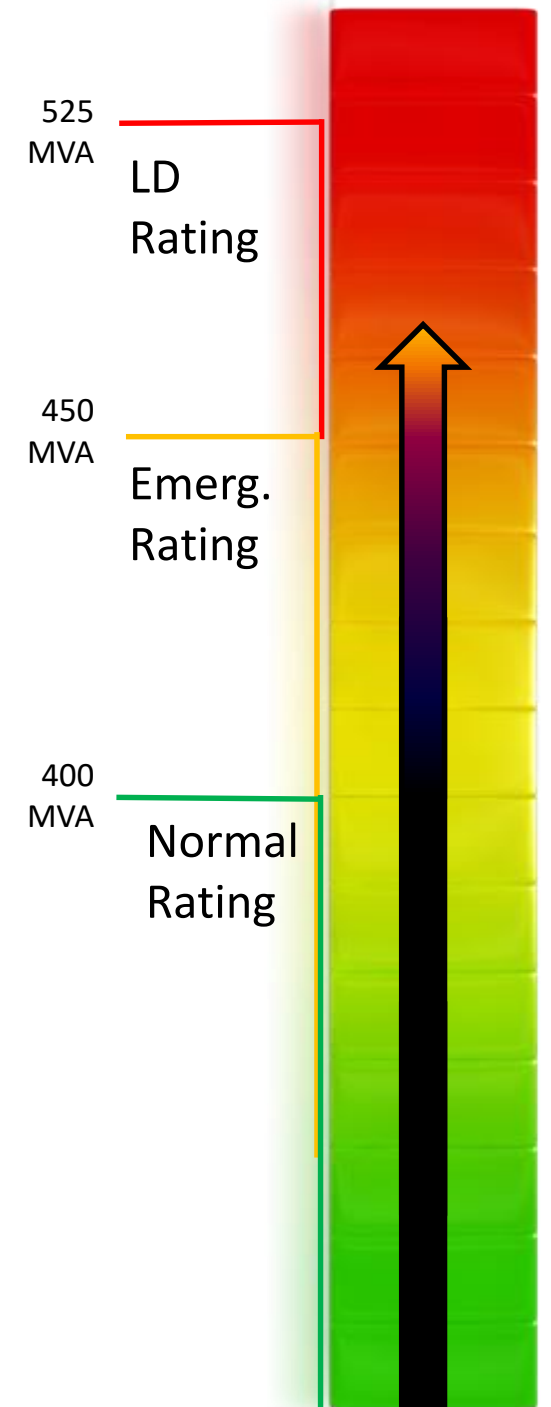

Example

Actual Flow (550 MVA) > LD:

- Corrective Actions include:
 - Non-cost
 - Off-cost
 - Load shed
- Load shed performed to return Actual flow below:
 - LD rating: **Within 5 minutes**
 - LTE rating: **Within time remaining**
 - Times are not cumulative!
- Relief needed:
 - 100 MVA
 - This may require more than 100 MVA of load shed based on Dfax

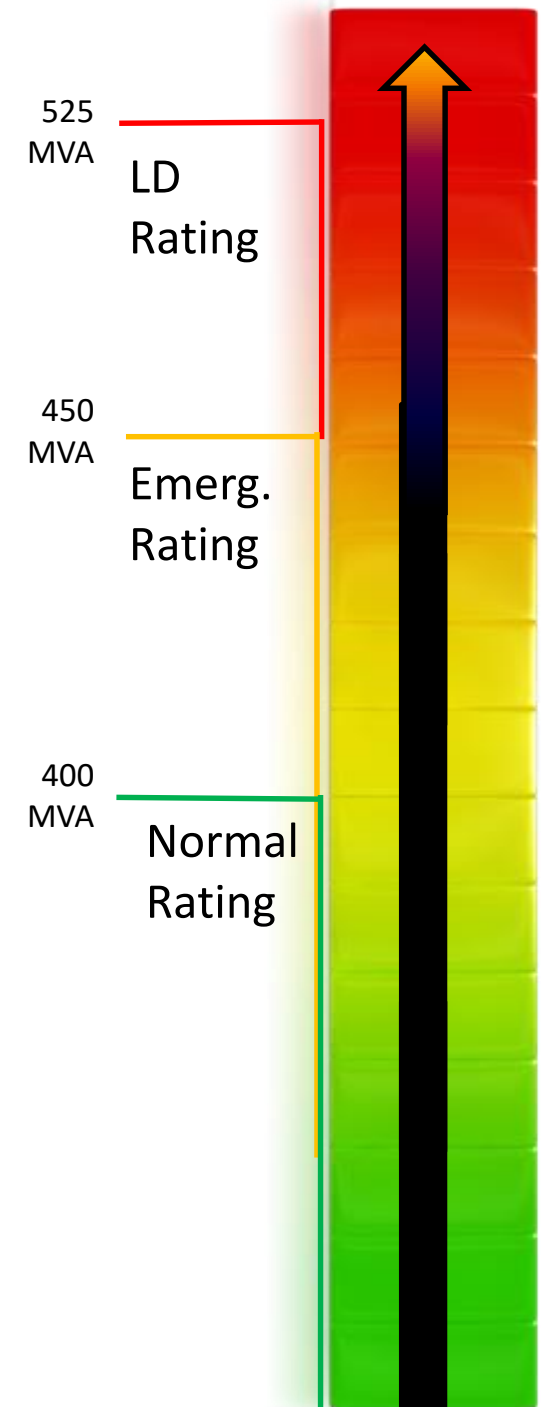

Normal, Long Term, Short Term and Load Dump Example

Example

If Actual Flow < Normal Rating:

- No corrective actions are required
- No limits are violated

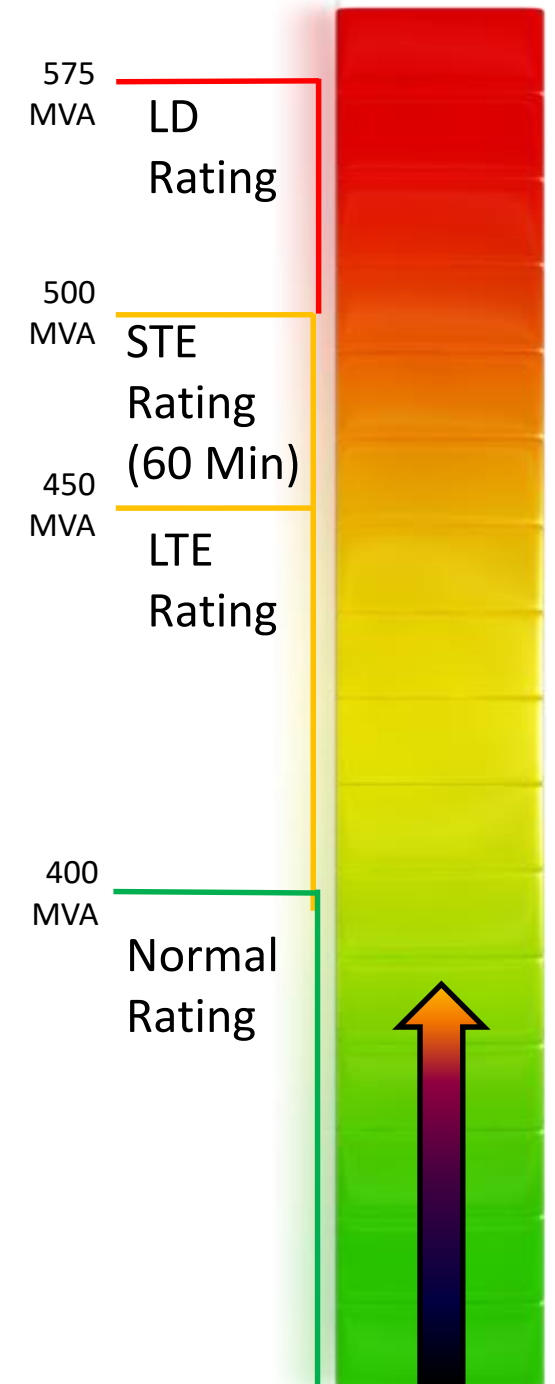

Example

Actual Flow (425 MVA) is < LTE but > Normal Rating:

- Corrective Actions include:
 - Non-cost
 - Off-cost options
 - No load shed would be performed
- Goal is to correct problem in:
 - **15 minutes**
 - May not be possible since load shed is not a controlling action

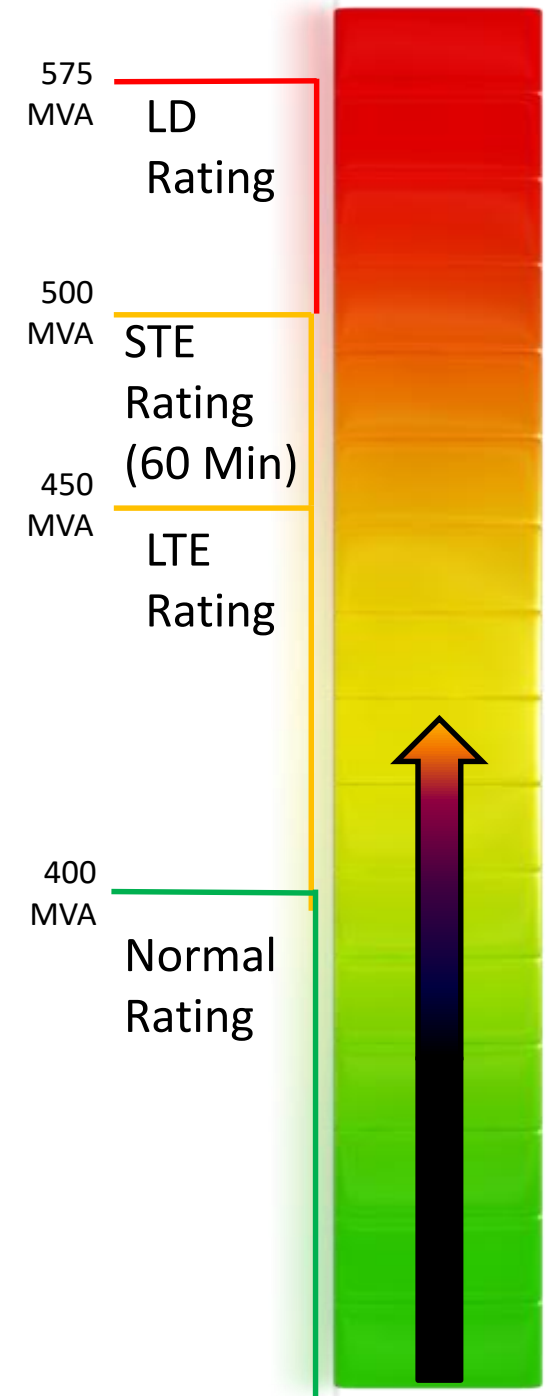

Example

Actual Flow (475 MVA) is > LTE but < STE:

- Corrective Actions include:
 - Non-cost
 - Off-cost
 - Load shed
- Load shed would be performed to return Actual flow:
 - LTE rating
 - Within the rating duration of the STE
 - In this example; within 60 minutes
- Relief needed:
 - 25 MVA
 - This may require more than 25 MVA of load shed based on distribution factor effect

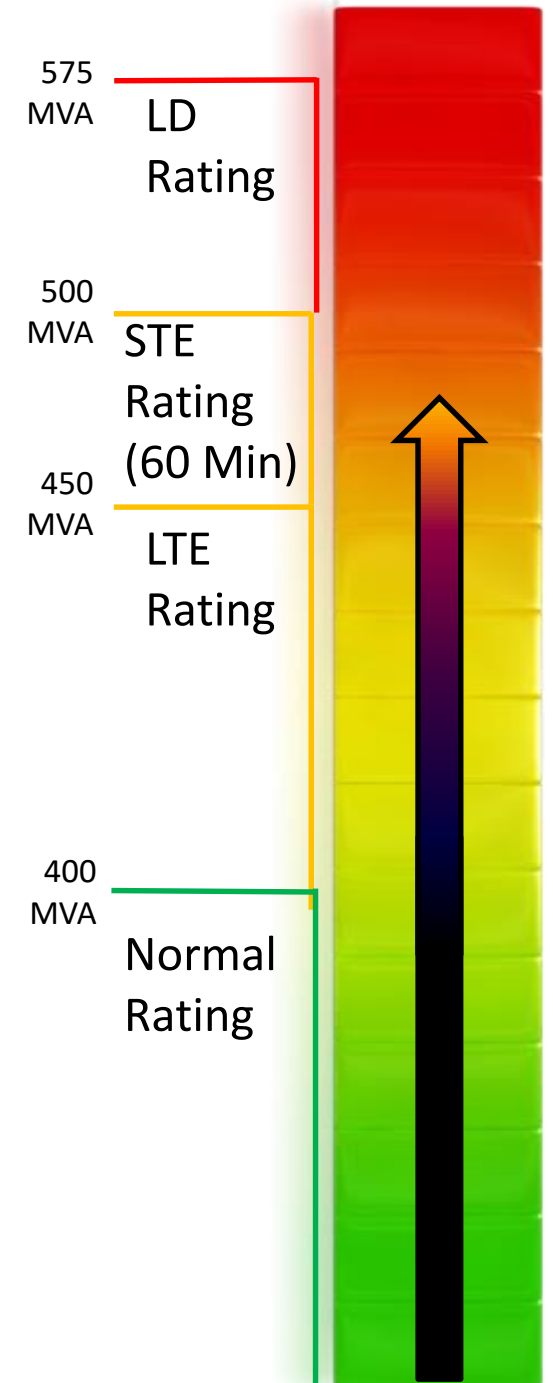

Example

Actual Flow (530 MVA) is > STE but < LD:

- Corrective Actions include:
 - Non-cost
 - Off-cost
 - Load shed
- Load shed performed to return Actual flow below:
 - STE rating: **Within 15 minutes**
 - LTE rating: **Within the remaining time**
 - Times are not cumulative!
- Relief needed:
 - 80 MVA
 - This may require more than 80 MVA of load shed based on Dfax

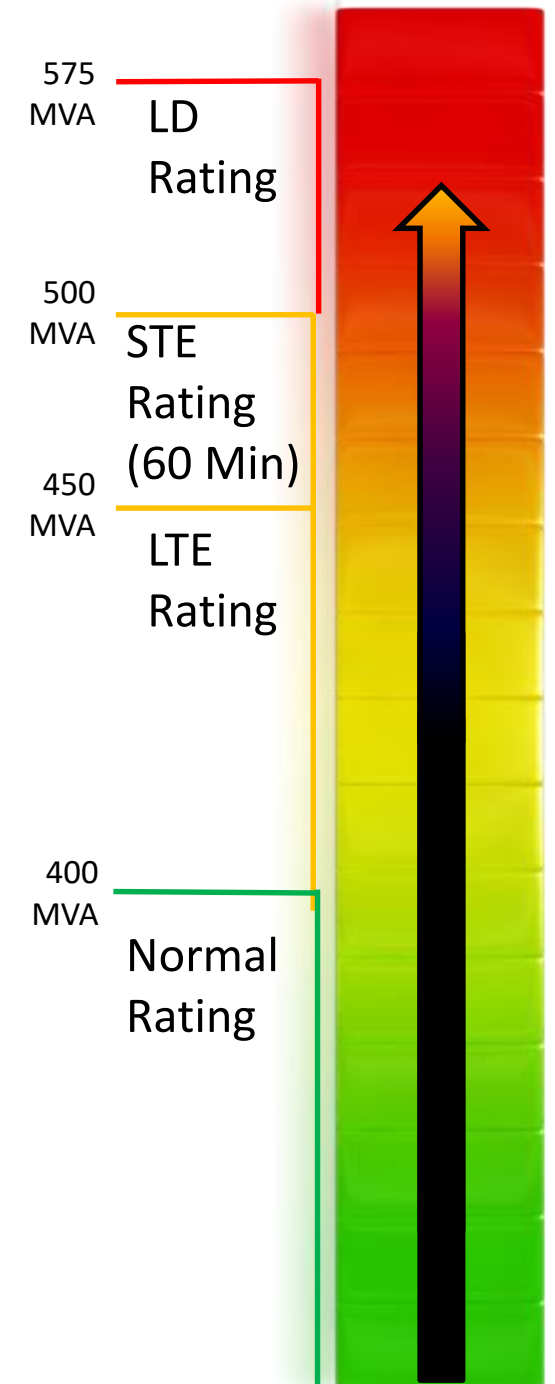

Example

Actual Flow (600 MVA) > LD:

- Corrective Actions include:
 - Non-cost
 - Off-cost
 - Load shed
- Load shed performed to return Actual flow below:
 - LD rating: **Within 5 minutes**
 - STE rating: **Within 15 minutes, or time remaining**
 - LTE rating: **Within 60 minutes, or time remaining**
 - Times are not cumulative!
- Relief needed:
 - 150 MVA
 - This may require more than 150 MVA of load shed based on Dfax

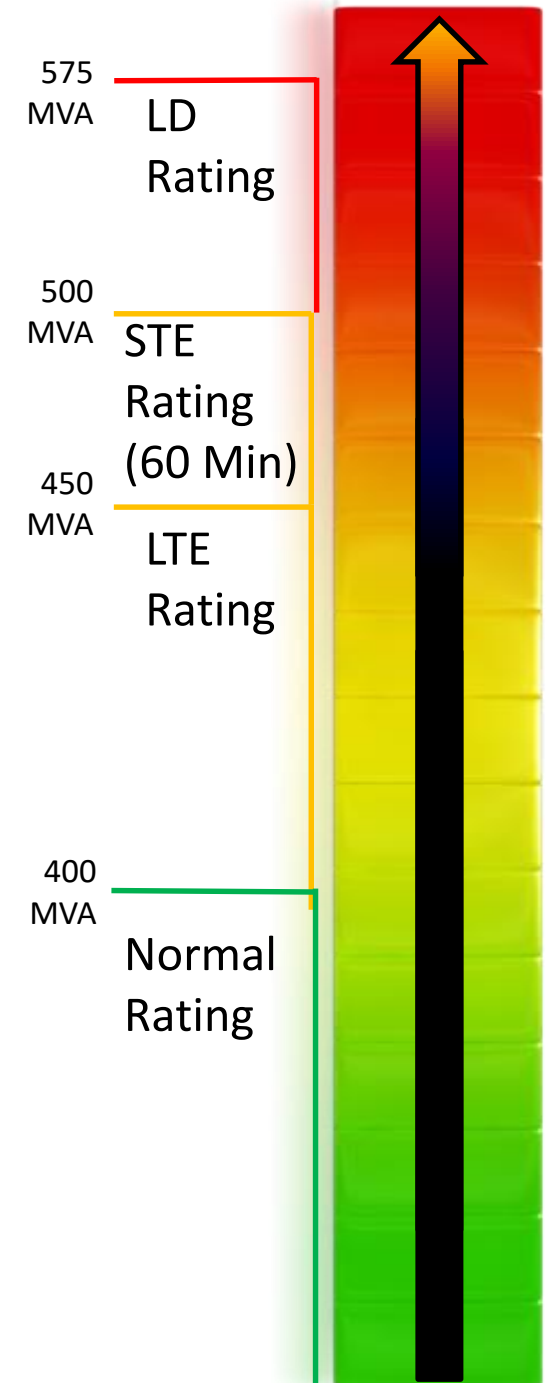

PJM Thermal Operating Criteria

Thermal Limit Exceeded	If Post Contingency simulated loading exceeds limit	Time to correct	Legend
Normal	Trend – continue to monitor. Take non-cost actions to prevent contingency from exceeding emergency limit	N/A	Non-Cost
Emergency	Use all effective actions and emergency procedures except load dump	30 minutes	Off-Cost
Load Dump	All of the above however, shed load only if necessary to avoid post-contingency cascading	30 minutes	Load Shedding

Exhibit 2: PJM Post-Contingency Simulated Thermal Operating Policy

Note : System readjustment should take place within 30 minutes. PCLLRW should be implemented as post-contingency violations approach 60 minutes in duration. However, PCLLRW can be issued sooner at the request of the Transmission Owner of if the PJM Dispatcher anticipates controlling actions cannot be realized within 60 minutes due to longer generator start-up + notification times

Consequences of Violating Thermal Limits

Consequences of Violating Thermal Limits

- Lines
 - Conductor Sag
 - Could lead to loss of the facility
 - Flows will be redistributed on other lines
 - Rule of Thumb - For the loss of a line flowing towards station, the other lines flowing toward station will increase while the lines flowing out of station will decrease
 - Rule of Thumb - For the loss of a line flowing out of a station, the other lines flowing out of station will increase while the lines flowing toward a station will decrease
 - Increased flows could lead to more overloads and if severe enough, possible cascading trips, system separation and blackout

Consequences of Violating Thermal Limits

- Transformers
 - Overheating may cause damage to the winding insulation or thermal damage to the oil
- Generators
 - Rotor and stator winding insulation damage
 - Generator could trip off line to protect it from damage
 - Results in possible voltage drop and MW and MVAR in-flow from the rest of the system
 - Affects on system power flows
 - Rule of Thumb - For a loss of generation, flows toward station will increase and flows out of station will decrease

Controlling Thermal Violations

- *Non-cost Responses to Thermal Violations*

- Restore tripped equipment quickly if possible
 - Generally cables and transformers are not reclosed following a tripping
- Remove faulted equipment from system
 - Isolate faulted equipment through switching
- Activate Special Purpose Relays
- Approved switching procedures
- Adjust Phase Angle Regulators (PARS)

Controlling Thermal Violations

- Off-cost Responses to Thermal Violations

- Curtail Non-firm transactions NOT willing to pay congestion
- Re-dispatch generation
- Cancel maintenance
 - Request return of outage equipment
- NERC Transmission Loading Relief (TLR)
- Initiate ALL Emergency Procedures EXCEPT Load Shed
 - Including Manual Load Dump Warning and Post Contingency Local Load Relief Warning

Controlling Thermal Violations

- **Load Shedding Response to Thermal Violations**
 - Determine if load shedding is required
 - All other control actions have been exhausted
 - Over emergency or load dump rating on an actual basis
 - Over load dump rating on contingency basis if analysis indicates potential for cascading thermal overloads
 - Determine amount of load shed necessary
 - Determine location of load shed
 - Local vs. System-wide
 - Shed load proportional among Native Load customers, Network customers and firm point-point service

Remedial Action Schemes (RAS)

Disclaimer

- This presentation explains the types of RAS that can be found on transmission and distribution systems
- Examples of RAS will be provided for schemes used in the PJM RTO
 - Each individual scheme on the PJM system is not covered in this presentation
- Further information regarding specific RAS in PJM can be located in **Section 5 of PJM Manual 3**

Introduction

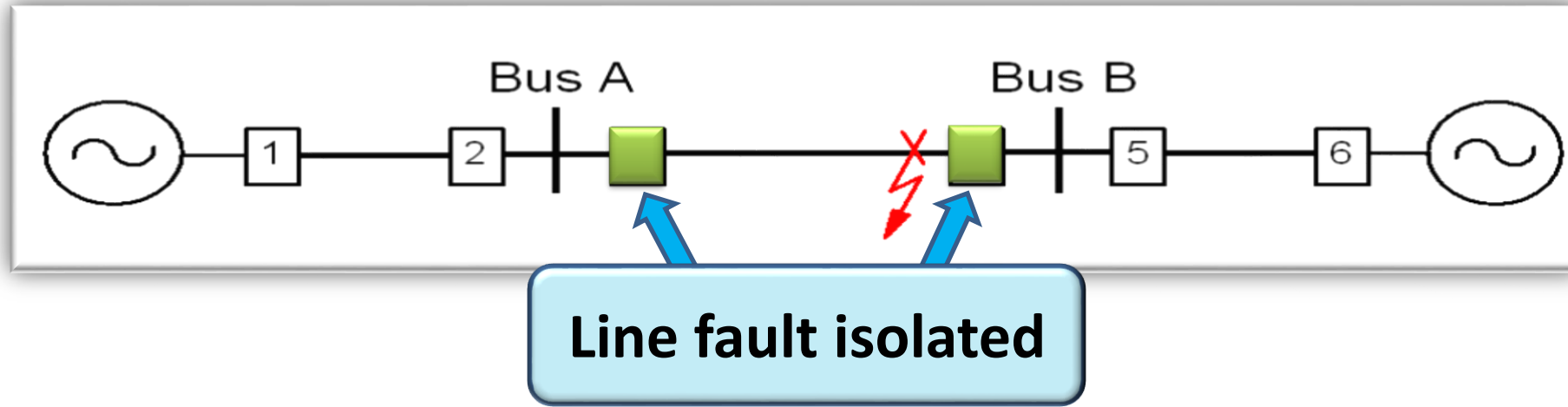

- Basic power system protection is designed to protect system equipment by isolating faulted equipment
- Examples include: generators, lines, transformers and busses

Problem Statement

- The size and complexity of the power grid makes the bulk electric system vulnerable to:
 - Congestion
 - Over/underfrequency
 - Over/undervoltage
 - Power system instability

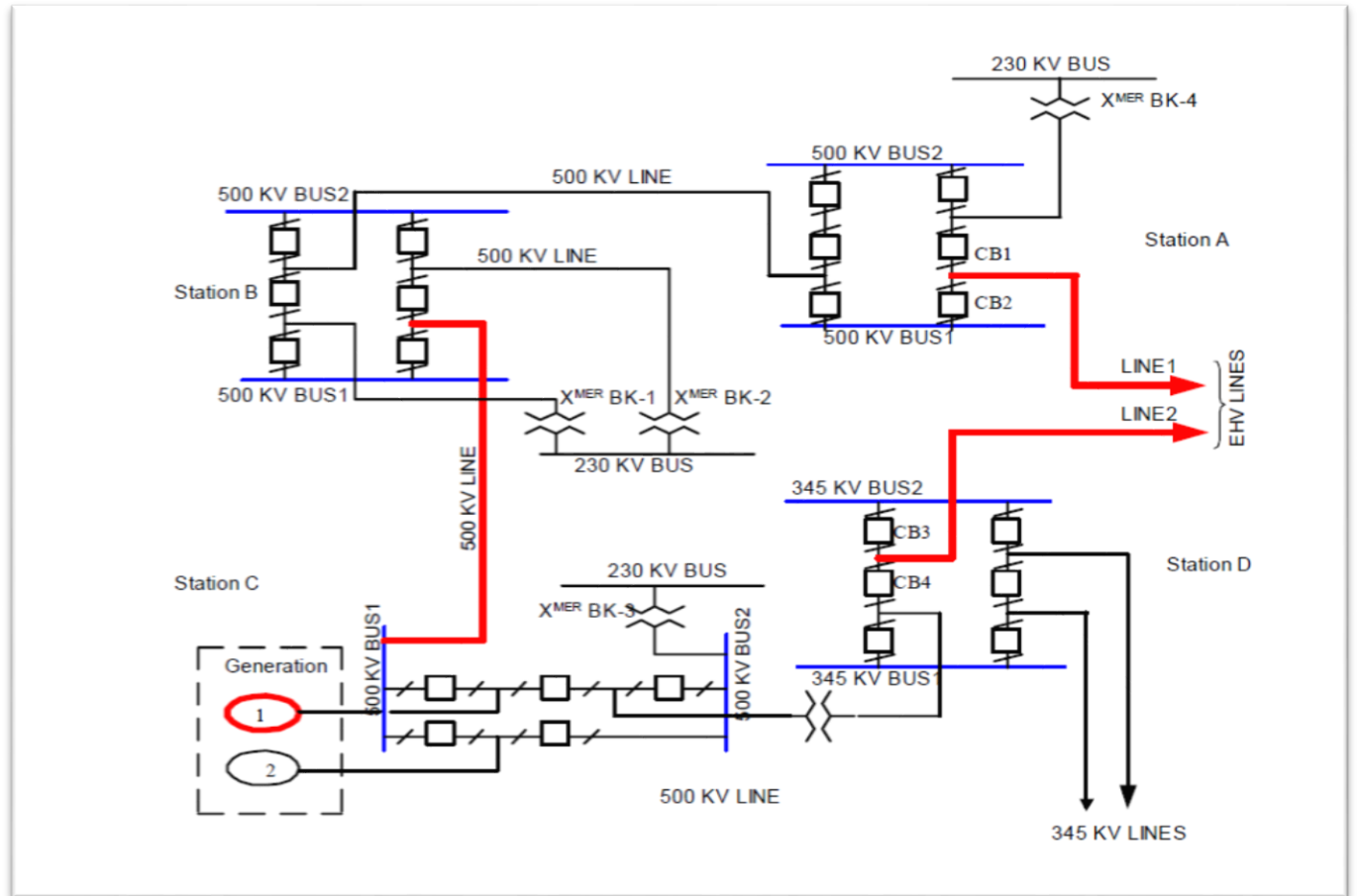

www.gedigitalenergy.com (2013)

Problem Statement

- Unaddressed system vulnerabilities could result in:
 - Multiple contingencies
 - Equipment damage
 - Power system collapse



Solution: Use Remedial Action Schemes (RAS)

- Remedial Action Scheme (RAS) is designed to **detect abnormal system conditions and initiate predetermined actions** to maintain the reliability of the Bulk Electric System (BES)
- Actions include:
 - Changes in demand
 - Changes in generation output
 - Changes in system configuration
- Goals of an RAS:
 - Maintain system stability
 - Maintain acceptable system voltages
 - Maintain all facilities within acceptable thermal limits



Criteria

- **Dependability:**
 - Certainty that the scheme operates when required to avoid a collapse
- **Security:**
 - Certainty that the scheme does not operate when not required
- **Selectivity:**
 - Ability to select the correct and minimum amount of action
- **Robustness:**
 - Ability of the scheme to provide dependability, security, and selectivity over the full range of dynamic and steady state operating conditions

NERC Standards

- As the Reliability Coordinator, Transmission Operator and Balancing Authority, PJM is responsible to monitor the status of all schemes in the RTO

PRC-001.1(ii) R6

R6. Each Transmission Operator and Balancing Authority shall monitor the status of each Special Protection System in their area, and shall notify affected Transmission Operators and Balancing Authorities of each change in status.

IRO-002-4 R5

R5. Each Reliability Coordinator shall monitor Facilities, the status of Remedial Action Schemes, and non-BES facilities identified as necessary by the Reliability Coordinator, within its Reliability Coordinator Area and neighboring Reliability Coordinator Areas to identify any System Operating Limit exceedances and to determine any Interconnection Reliability Operating Limit exceedances within its Reliability Coordinator Area. *[Violation Risk Factor: High] [Time Horizon: Real-Time Operations]*

RAS Requirements

Relays



Communication Network

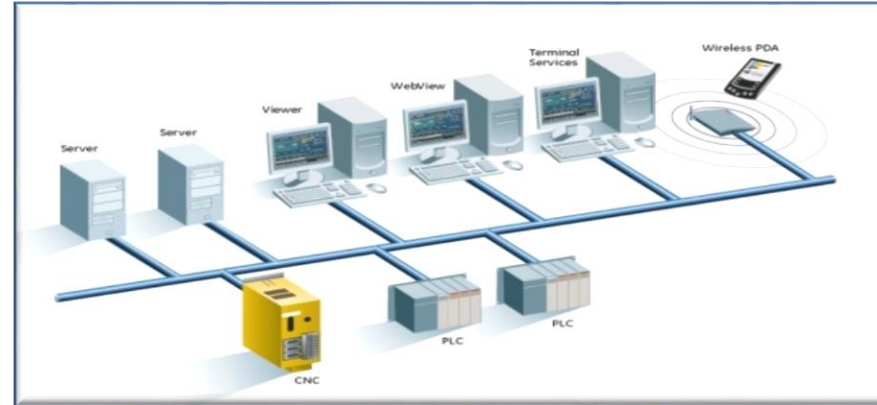

Scheme Logic

IF circuit breaker X trips *THEN* circuit breakers Y and Z will ____?

PJM RAS Review Process

- PJM Manual 3: Section 1.7
 - PJM receives proposal for RAS
 - Must meet NERC RAS definition
 - PJM and TO review scheme and system impacts
 - PJM provides recommendation and identifies if scheme is needed for reliability purposes including operational performance
 - PJM posts scheme information and document scheme in M-03
 - Owner obtains RRO approval and discusses at various committee meetings

PJM RAS Identification

- PJM will always use the following format to identify RAS:

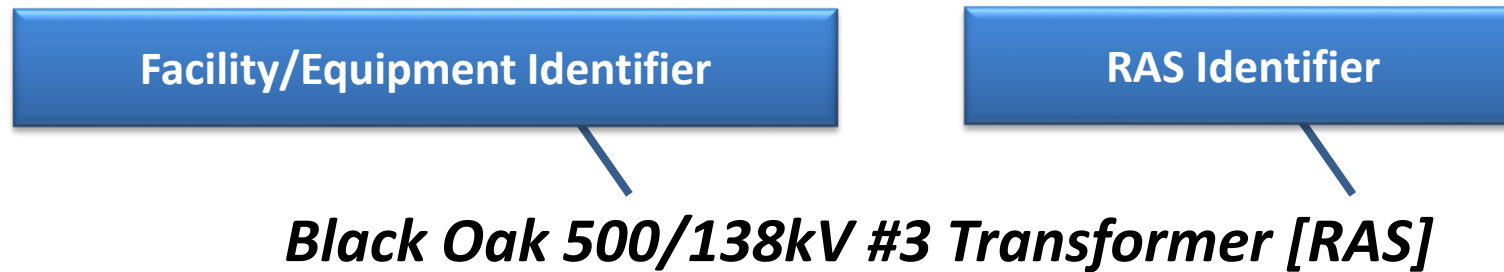

RAS Questions for Activation

- Does the scheme require manual activation (communication protocol)?
- What are the conditions that will activate the scheme?
- What conditions make the scheme nonfunctional?
- What procedures are in place should the RAS become unavailable?
- Is my contingency analysis modeled properly based on the relay scheme logic?
- Is the bulk electric system in a reliable posture following the activation of the RAS?

Types of RAS

Types of RAS

- Remedial Action Scheme is designed to perform several functions. These include:
 - Trip or transfer trip a facility
 - Initiate generator load rejection schemes

Trip Scheme

- Will initiate breaker operation to mitigate overload

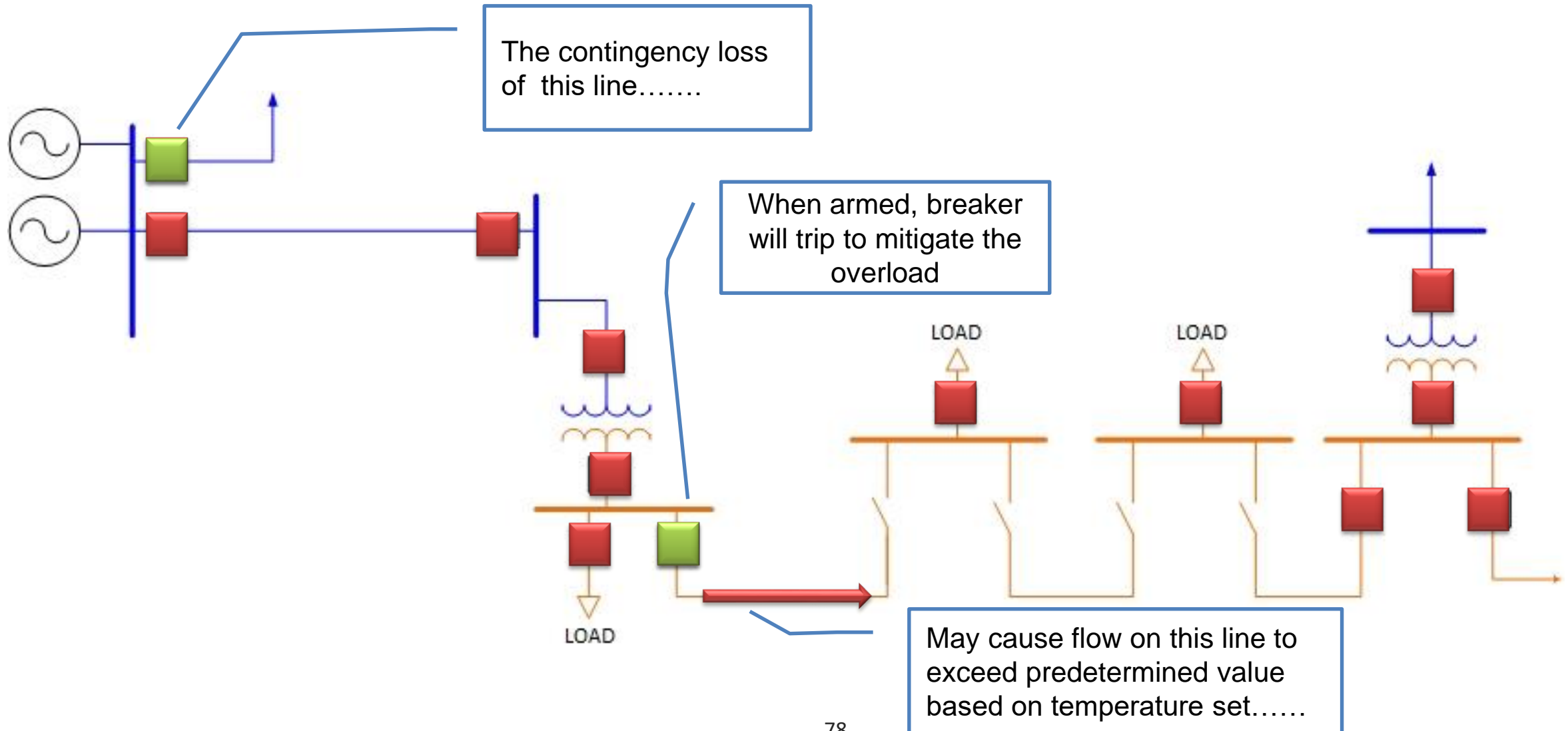

Transfer Trip Scheme

- Will coordinate breaker operations to initiate remote tripping based on a predetermined set of conditions

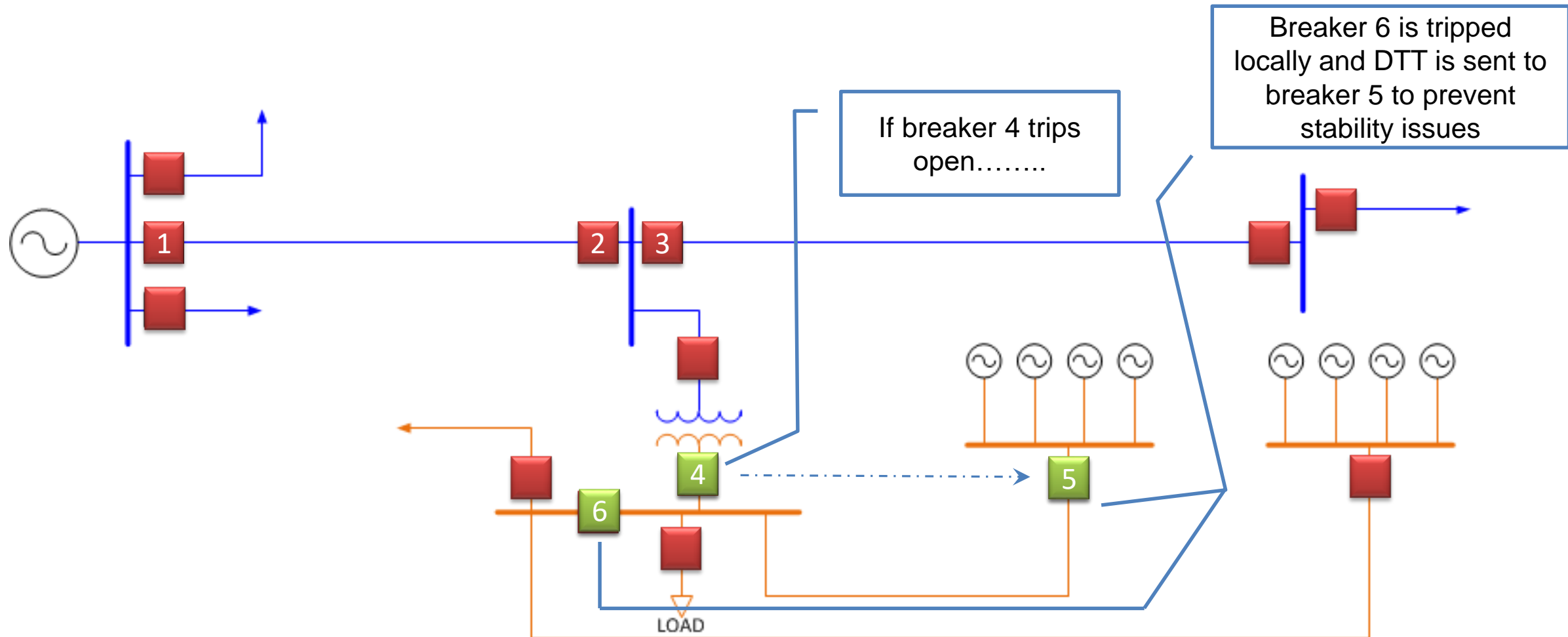

Generation Load Rejection

- Used to maintain system stability following loss of load events
 - Full Load Rejection
- Most PJM generator runback schemes are Full Load Rejection

Generation Load Rejection

- Full Load Rejection
 - Main generator breakers trip
 - Loss of synchronization and full load
 - Steam generators runback from full load to no-load

Generation Load Rejection

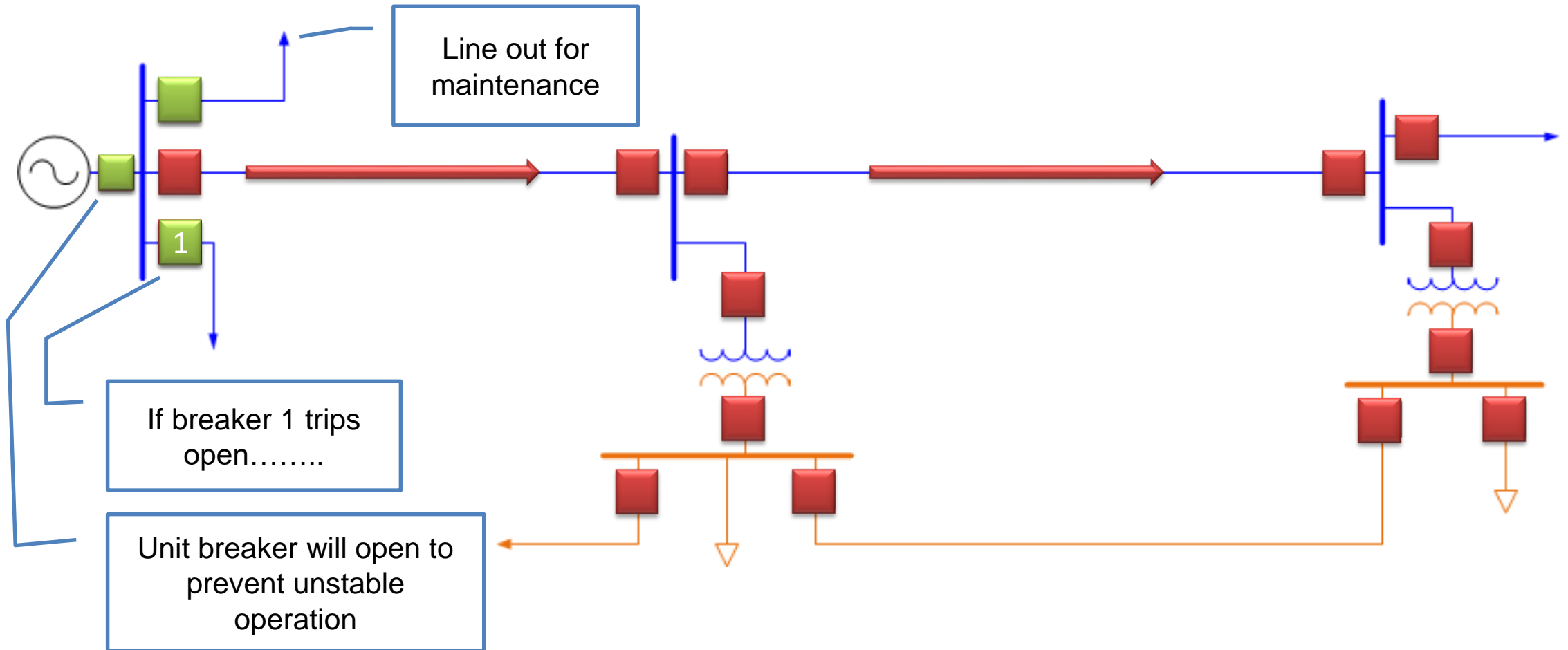

PJM RAS Actions

1. PJM will contact the TO to verify EMS results and direct the RAS to be Enabled
2. PJM will modify the contingency definition to simulate the N-1 condition in the EMS with the RAS activated
3. PJM will log the activation/deactivation of the RAS scheme that is a change from its “Normal” status
4. PJM will control all actual facility loadings below the Normal ratings and all contingency loadings below the Emergency rating

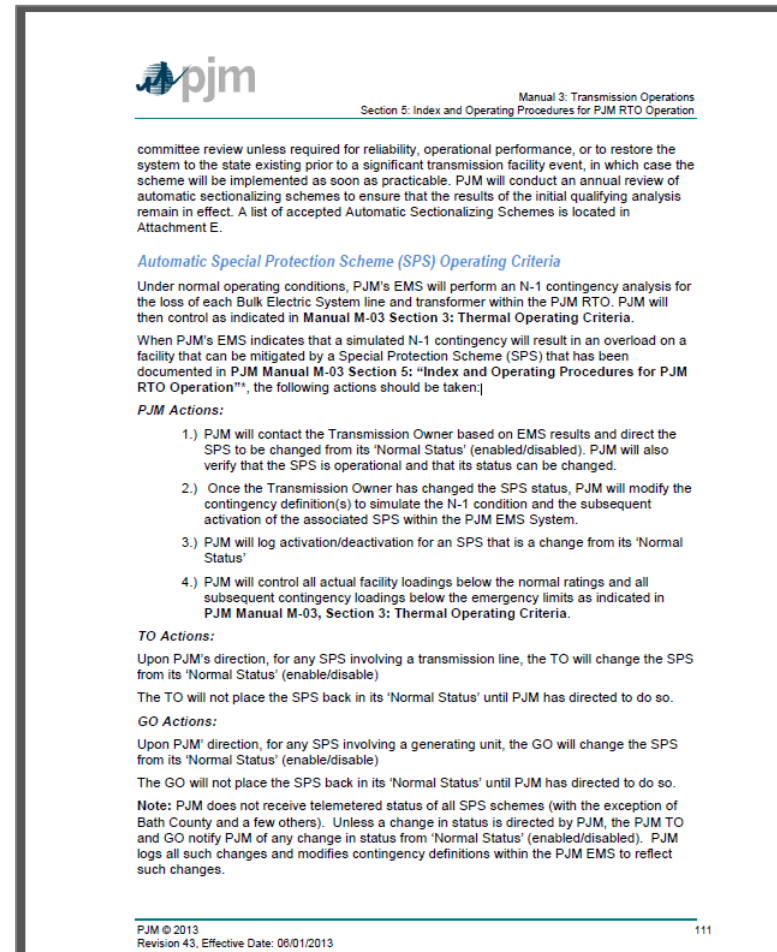

 Manual 3: Transmission Operations
Section 5: Index and Operating Procedures for PJM RTO Operation

committee review unless required for reliability, operational performance, or to restore the system to the state existing prior to a significant transmission facility event, in which case the scheme will be implemented as soon as practicable. PJM will conduct an annual review of automatic sectionalizing schemes to ensure that the results of the initial qualifying analysis remain in effect. A list of accepted Automatic Sectionalizing Schemes is located in Attachment E.

Automatic Special Protection Scheme (SPS) Operating Criteria

Under normal operating conditions, PJM's EMS will perform an N-1 contingency analysis for the loss of each Bulk Electric System line and transformer within the PJM RTO. PJM will then control as indicated in Manual M-03 Section 3: Thermal Operating Criteria.

When PJM's EMS indicates that a simulated N-1 contingency will result in an overload on a facility that can be mitigated by a Special Protection Scheme (SPS) that has been documented in PJM Manual M-03 Section 5: "Index and Operating Procedures for PJM RTO Operation", the following actions should be taken:

PJM Actions:

- 1.) PJM will contact the Transmission Owner based on EMS results and direct the SPS to be changed from its 'Normal Status' (enabled/disabled). PJM will also verify that the SPS is operational and that its status can be changed.
- 2.) Once the Transmission Owner has changed the SPS status, PJM will modify the contingency definition(s) to simulate the N-1 condition and the subsequent activation of the associated SPS within the PJM EMS System.
- 3.) PJM will log activation/deactivation for an SPS that is a change from its 'Normal Status'
- 4.) PJM will control all actual facility loadings below the normal ratings and all subsequent contingency loadings below the emergency limits as indicated in PJM Manual M-03, Section 3: Thermal Operating Criteria.

TO Actions:

Upon PJM's direction, for any SPS involving a transmission line, the TO will change the SPS from its 'Normal Status' (enable/disable)

The TO will not place the SPS back in its 'Normal Status' until PJM has directed to do so.

GO Actions:

Upon PJM's direction, for any SPS involving a generating unit, the GO will change the SPS from its 'Normal Status' (enable/disable)

The GO will not place the SPS back in its 'Normal Status' until PJM has directed to do so.

Note: PJM does not receive telemetered status of all SPS schemes (with the exception of Bath County and a few others). Unless a change in status is directed by PJM, the PJM TO and GO notify PJM of any change in status from 'Normal Status' (enabled/disabled). PJM logs all such changes and modifies contingency definitions within the PJM EMS to reflect such changes.

PJM © 2013
Revision 43, Effective Date: 06/01/2013 111

PJM TO/GO RAS Actions

1. TO/GO will change the RAS status upon PJM's direction

2. TO/GO will not change the RAS status back to "Normal" unless directed to do so by PJM

3. TO/GO must report any condition that would prevent the use of the RAS or cause the RAS to become inoperable



committee review unless required for reliability, operational performance, or to restore the system to the state existing prior to a significant transmission facility event, in which case the scheme will be implemented as soon as practicable. PJM will conduct an annual review of automatic sectionalizing schemes to ensure that the results of the initial qualifying analysis remain in effect. A list of accepted Automatic Sectionalizing Schemes is located in Attachment E.

Automatic Special Protection Scheme (SPS) Operating Criteria

Under normal operating conditions, PJM's EMS will perform an N-1 contingency analysis for the loss of each Bulk Electric System line and transformer within the PJM RTO. PJM will then control as indicated in **Manual M-03 Section 3: Thermal Operating Criteria**.

When PJM's EMS indicates that a simulated N-1 contingency will result in an overload on a facility that can be mitigated by a Special Protection Scheme (SPS) that has been documented in **PJM Manual M-03 Section 5: "Index and Operating Procedures for PJM RTO Operation"**, the following actions should be taken:

PJM Actions:

- 1.) PJM will contact the Transmission Owner based on EMS results and direct the SPS to be changed from its 'Normal Status' (enabled/disabled). PJM will also verify that the SPS is operational and that its status can be changed.
- 2.) Once the Transmission Owner has changed the SPS status, PJM will modify the contingency definition(s) to simulate the N-1 condition and the subsequent activation of the associated SPS within the PJM EMS System.
- 3.) PJM will log activation/deactivation for an SPS that is a change from its 'Normal Status'
- 4.) PJM will control all actual facility loadings below the normal ratings and all subsequent contingency loadings below the emergency limits as indicated in **PJM Manual M-03, Section 3: Thermal Operating Criteria**.

TO Actions:

Upon PJM's direction, for any SPS involving a transmission line, the TO will change the SPS from its 'Normal Status' (enable/disable)

The TO will not place the SPS back in its 'Normal Status' until PJM has directed to do so.

GO Actions:

Upon PJM' direction, for any SPS involving a generating unit, the GO will change the SPS from its 'Normal Status' (enable/disable)

The GO will not place the SPS back in its 'Normal Status' until PJM has directed to do so.

Note: PJM does not receive telemetered status of all SPS schemes (with the exception of Bath County and a few others). Unless a change in status is directed by PJM, the PJM TO and GO notify PJM of any change in status from 'Normal Status' (enabled/disabled). PJM logs all such changes and modifies contingency definitions within the PJM EMS to reflect such changes.

Thermal Limits Exercises

Thermal Limit Exercises

Scenario #1:

On a 77° summer day there are 2546 MW and 1823 MVAR flowing on the Elmer-Wenatchee 500 kV line.

Is the flow exceeding any actual thermal limit? If so which one, how much relief is needed, and how long do you have to correct and what actions are used?

Thermal Limit Exercises

Scenario #2:

On a 41° winter evening there are 582 MW and 175 MVAR flowing on the Ellensburg-Wenatchee 230 kV line.

Is the flow exceeding any actual thermal limit? If so which one, how much relief is needed, and how long do you have to correct and what actions are used?

Thermal Limit Exercises

Scenario #3:

On a 50° autumn morning there are 3218 MW and 1891 MVAR flowing on the Everett-Wenatchee 500 kV line.

Is the flow exceeding any actual thermal limit? If so which one, how much relief is needed, and how long do you have to correct and what actions are used?

Thermal Limit Exercises

Scenario #4:

On that same 77° summer day your security analysis program shows that for the loss of the Elmer-Wenatchee 500 kV line the flow on Ellensburg-Wenatchee 230 kV line would go up to 701 MVA

Is the flow exceeding any post-contingency simulated thermal limit? If so which one, how much relief is needed, and how long do you have to correct and what actions are used?

Thermal Limit Exercises

Scenario #5:

On a 41° winter evening your security analysis program shows that for the loss of the Ellensburg-Wenatchee 230 kV line the flow on Elmer-Wenatchee 500 kV line would go up to 3133 MVA.

Is the flow exceeding any post-contingency simulated thermal limit? If so which one, how much relief is needed, and how long do you have to correct and what actions are used?

Thermal Limit Exercises

Scenario #6:

On a 50° autumn morning your security analysis program shows that for the loss of the Ellensburg-Wenatchee 500 kV line the flow on Everett-Wenatchee 500 kV line would go up to 3333 MVA.

Is the flow exceeding any post-contingency simulated thermal limit? If so which one, how much relief is needed, and how long do you have to correct and what actions are used?

IROLs in PJM

How are IROLs determined and Monitored within PJM?

- PJM Manual 37 outlines the IROLs within the PJM footprint, and how they are monitored
- IROL analysis is performed in:
 - long-term and short-term planning studies
 - day-ahead studies
 - real time
- Studies include a long list of possible contingencies
 - studied at estimated peak loads
 - include facilities identified as requiring special attention
 - Facilities contributing to the 2003 Blackout
 - The RFC (ECAR) list of critical facilities
 - MAAC assessment limits
 - Others identified by operating experience

How are IROLs determined and Monitored within PJM?

- Flows are increased across a given piece of equipment or interface
 - Looking for any resulting voltage and thermal violations
 - PJM EMS increases load in Eastern PJM (sink) with an increase in Western Generation (MISO) until a voltage violation (or collapse) is identified
- Thermal limit violations alone allow PJM (and company) Dispatchers time to respond without jeopardizing system reliability, and are ***NOT*** IROLs

How are IROLs determined and Monitored within PJM?

- PJM classifies a facility as an IROL facility:
 - If wide-area voltage violations occur at transfer levels that are near the Load Dump thermal limit
 - Plus case-by-case exceptions as identified in the studies
- In most cases, the IROLs are a limit on MW flows to prevent a ***post-contingency*** voltage violation or collapse...

How are IROLs determined and Monitored within PJM?

- Determination of Reactive Transfer Limits
 - Limits are calculated every 2 – 5 minutes on PJM's EMS
 - Each transfer interface has its own set of contingencies and monitored buses



What Are the IROLs in the PJM Footprint?

- The Reactive Transfer Limit for an interface is determined as the more restrictive of:
 - The minimum pre-contingency transfer interface flow where a post-contingency voltage drop violation (5%) or post-contingency low voltage violation first occurs

OR

- The minimum pre-contingency transfer interface flow with a converged power flow solution minus the user specified MW “back-off” value
 - Generally 50 – 300 MW

What Are the IROLs in the PJM Footprint?

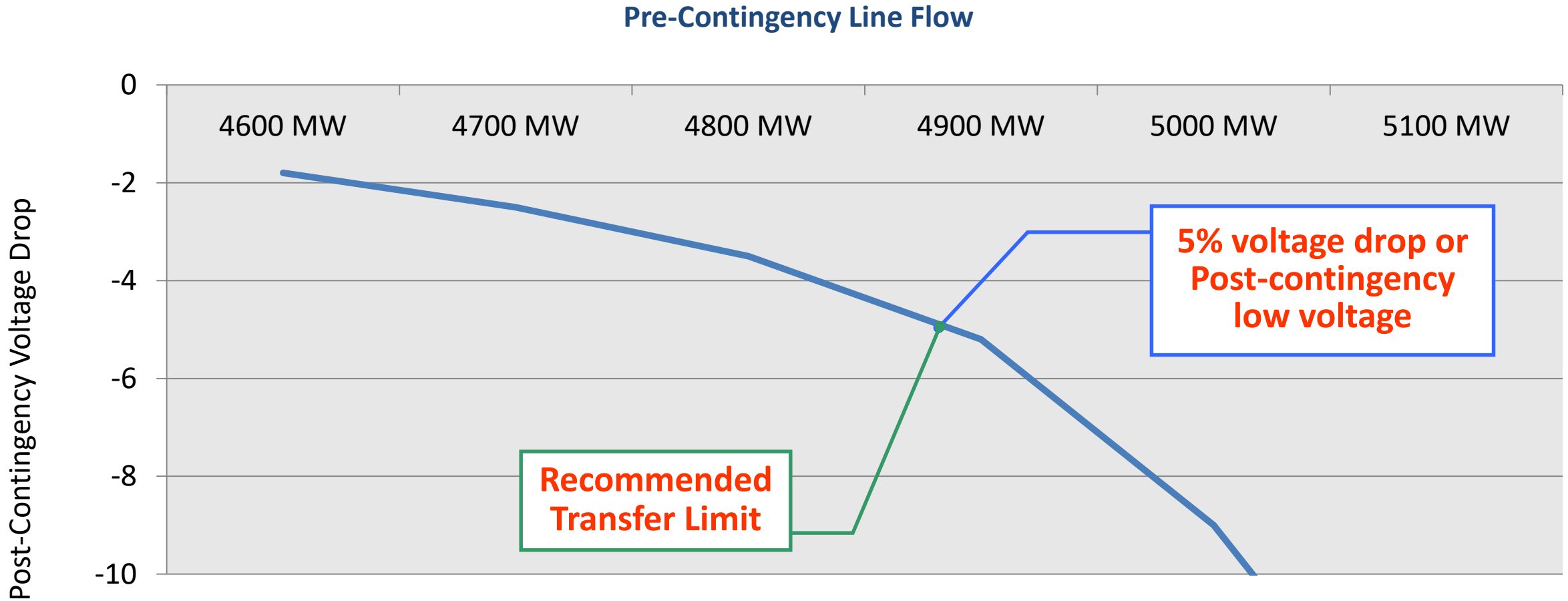

What Are the IROLs in the PJM Footprint?

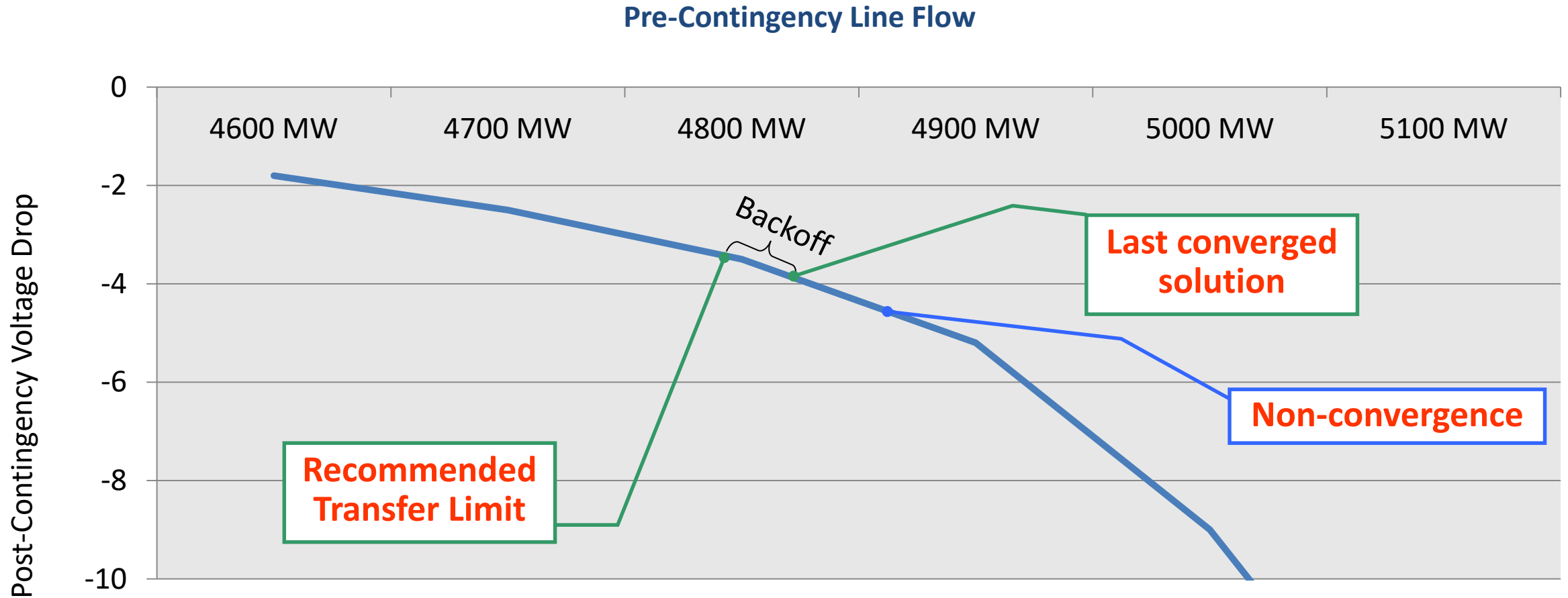

What Are the Reactive Transfer interfaces within the PJM Footprint?

Transfer Interface	Interface Definition (From Bus - To Bus)
<p><i>Eastern</i> (Eastern)</p>	<ul style="list-style-type: none"> • 5059 Breinigsville – Alburtis #1 500 kV line • 5058 Breinigsville – Alburtis #2 500 kV line • 5009 Juniata – Alburtis 500 kV line • 5066 Lauschtown – Hosensack 500 kV line • 5010 Peach Bottom – Limerick 500 kV line • 5025 Rock Springs – Keeney 500 kV line • 5063 Lackawanna - Hopatcong 500 kV line
<p><i>Central</i> (Central)</p>	<ul style="list-style-type: none"> • 5004 Keystone – Juniata 500 kV line • 5005 Conemaugh – Juniata 500 kV line • 5012 Conastone – Peach Bottom 500 kV line

What Are the Reactive Transfer interfaces within the PJM Footprint?

<p>5004/5005 (5004/5005)</p>	<ul style="list-style-type: none"> • 5004 Keystone – Juniata 500 kV line • 5005 Conemaugh – Juniata 500 kV line
<p>Western (Western)</p>	<ul style="list-style-type: none"> • 5004 Keystone – Juniata 500 kV line • 5005 Conemaugh – Juniata 500 kV line • 5068 Vinco – Hunterstown 500 kV line • 5055 / 522 Doubs – Brighton 500 kV line
<p>Bedington – Black Oak (Bed-Bla)</p>	<ul style="list-style-type: none"> • 544 Black Oak – Bedington 500 kV line

What Are the Reactive Transfer interfaces within the PJM Footprint?

<i>AP South</i> (AP South)	<ul style="list-style-type: none">• 583 Bismark – Doubs 500 kV line• 540 Greenland Gap – Meadow Brook 500 kV line• 550 Mt. Storm – Valley 500 kV line• 529 Mt. Storm – Meadow Brook 500 kV line
<i>AEP - Dominion</i> (AEP-DOM)	<ul style="list-style-type: none">• Kanawha River – Matt Funk 345 kV line• Wyoming – Jacksons Ferry 765 kV line• Baker – Broadford 765 kV line

What Are the Reactive Transfer interfaces within the PJM Footprint?

<i>Cleveland</i> (CLVLND)	<ul style="list-style-type: none">• Hanna – Chamberlin 345 kV line• Hanna – Juniper 345 kV line• Star – Juniper 345 kV line• Star – North Medina 345 kV line• Erie West – Ashtabula 345 kV line• Mansfield – Glenwillow 345 kV line• Monroe – Lallendorf 345 kV line
-------------------------------------	--

What Are the Reactive Transfer interfaces within the PJM Footprint?

<p><i>CE-East</i> (CE-EAST)</p>	<ul style="list-style-type: none">• Dumont - Wilton Center 765 kV line• Olive - University Park North 345 kV line• St. Johns - Crete 345 kV line• Sheffield - Burnham 345 kV line• Sheffield - Stateline 345 kV line• Munster - Burnham 345 kV line
--	--

What Are the Reactive Transfer interfaces within the PJM Footprint?

<p>BC/PEPCO (BC/PEPCO)</p>	<ul style="list-style-type: none">• 5055/522 Doubs - Brighton 500 kV line• 5013 Hunterstown - Conastone 500 kV line• 5012 Peach Bottom - Conastone 500 kV line• 560/5070 Possum Point – Burches Hill 500 kV line• Aqueduct - Dickerson 230 kV line• Doubs – Dickerson 23102 230 kV line• Cooper – Graceton 230 kV line• Edwards Ferry – Dickerson 230 kV line• Otter Creek – Conastone 230 kV line• Safe Harbor - Graceton 230 kV line• Face Rock – Five Forks #1 115 kV line• Face Rock – Five Forks #2 115 kV line
---------------------------------------	---

Current IROL facilities as defined within the PJM footprint:

Transfer Limit/Thermal Rating	Reportable IROL Violation
Eastern Reactive Transfer Interface	Flow exceeds Last Convergent Case Limit for 30 minutes (T_v)
Central Reactive Transfer Interface	Flow exceeds Last Convergent Case Limit for 30 minutes (T_v)
5004/5005 Reactive Transfer Interface	Flow exceeds Last Convergent Case Limit for 30 minutes (T_v)
Western Reactive Transfer Interface	Flow exceeds Last Convergent Case Limit for 30 minutes (T_v)
AP South Reactive Transfer Interface	Flow exceeds Last Convergent Case Limit for 30 minutes (T_v)
Bedington – Black Oak Reactive Transfer Interface	Flow exceeds Last Convergent Case Limit for 30 minutes (T_v)
AEP-DOM Reactive Transfer Limit	Flow exceeds Last Convergent Case Limit for 30 Minutes (T_v)
Cleveland (CLVLND) Reactive Transfer Interface	Flow exceeds Last Convergent Case Limit for 30 Minutes (T_v)
CE - East Reactive Transfer Interface	Flow exceeds Last Convergent Case Limit for 30 Minutes (T_v)

IROL Load Shed Procedure

- Purpose of the IROL Manual Load Dump:
 - Provide loading relief on IROL facilities as a last step
 - Prevent exceeding an IROL Limit for 30 minutes (IROL Violation)
 - Quickly act to mitigate IROL facilities in accordance with operating procedures
 - PJM Transmission Operations Manual (M03)
 - Section 2: Thermal Operating Guidelines
 - Section 3: Voltage & Stability Operating Guidelines
 - PJM Emergency Operations Manual (M13)
 - Section 5: Transmission Security Emergencies

IROL Load Shed Procedure

- IROL Manual Load Dump Warning
 - Issued via the PJM All-Call System when the IROL Limit has been exceeded for **5 minutes** or longer
 - The purpose is to **PREPARE** Transmission dispatchers/LSEs to curtail load within 5 minutes to return flows below the IROL Limit

IROL Load Shed Procedure

- IROL Manual Load Dump Warning
 - Transmission Owner Operators/LSEs
 - Once an IROL Manual Load Dump Warning has been implemented:
 - Promptly review IROL Manual Load Dump Allocation Table (Attachment N, M-13) in preparation of Manual Load Dump
 - To determine your required amount of Load Shed, determine your company multiplier for that IROL
 - Multiply the amount of relief requested by PJM by your multiplier to determine your company's load shed amount
 - Validate Load Dump Plan, Identifying critical or priority load(s)
 - **PREPARE** to shed load

IROL Load Shed Procedure

- IROL Manual Load Dump Action
 - Issue via the PJM All-Call System when the IROL Limit has been exceeded for up to **25 minutes**.
 - PJM dispatch:
 - Notifies PJM management
 - Public information personnel, and members
 - Other Control Areas through the RCIS
 - Notifies DOE, FEMA, and NERC
 - Notifies FERC via the FERC Division of Reliability's electronic pager system

IROL Load Shed Procedure

- IROL Manual Load Dump Action

- Transmission Owner Operators/LSEs

- Promptly (**within 5 minutes**) shed an amount of load equal to or in excess of the amount requested by PJM dispatcher in accordance with Attachment N, but consider/recognize priority/critical load
 - A Grey Box on Attachment N indicates your company has no responsibility to shed load for that IROL
 - Notify governmental agencies, as applicable
 - Maintain the requested amount of load relief until the load dump order is cancelled

IROL Load Shed Procedure

IROL	East	Central	5004/05	West	AP South	Bed-BO	AEP/DOM	CLVLND	CE-EAST
TO Zone	Multiplier	Multiplier	Multiplier	Multiplier	Multiplier	Multiplier	Multiplier	Multiplier	Multiplier
DPL	0.21	0.16	0.40	0.18					
DPL-Dover	0.01	0.01	0.02	0.01					
DPL-DEMEC	0.02	0.01	0.03	0.02					
DPL-Easton	0.00	0.00	0.01	0.00					
DPL-ODEC	0.05	0.04	0.10	0.05					
AE	0.14	0.11	0.27	0.12					
AE-Vineland	0.01	0.01	0.02	0.01					
PS	0.59	0.46	1.10	0.49					
RECO	0.02	0.02	0.04	0.02					
PE	0.60	0.47	1.12	0.50					
FE East-JC	0.32	0.25	0.60	0.27					
PL		0.51	1.23	0.55					
UGI		0.01	0.03	0.01					
FE East-ME		0.18	0.43	0.19					
FE East-PN									
BC				0.44	0.93	3.98	1.48		
PEP				0.35	0.75	3.20	1.19		
PEP-SMECO				0.05	0.10	0.44	0.17		
FE South									
Dom					2.91	4.10	4.62		
Dom-NCEME					0.26	1.11	0.41		
Dom-ODEC					0.05	0.19	0.07		
DLCO									
AEP							1.00		
Dayton									
FE West								0.93	
CPP								0.07	
ComEd									0.998
DEOK									
EKPC									
Rochelle									0.002

IROL Load Shed Procedure

- **Example:** IROL Load Shed Request
 - PJM announces an IROL Load Shed Warning for 350 MW of Relief on the Western Transfer IROL
 - Your company is Public Service (PS)
 - You consult Attachment N and determine that your company Multiplier for the Western Transfer IROL is 0.49

IROL Load Shed Procedure

Attachment N: IROL Load Dump Tables

IROL	East	Central	5004/05	West	AP South	Bed-BO	AEP/DOM	CLVLND	CE-EAST
TO Zone	Multiplier	Multiplier	Multiplier	Multiplier	Multiplier	Multiplier	Multiplier	Multiplier	Multiplier
DPL	0.21	0.16	0.40	0.18					
DPL-Dover	0.01	0.01	0.02	0.01					
DPL-DEMEC	0.02	0.01	0.03	0.02					
DPL-Easton	0.00	0.00	0.01	0.00					
DPL-ODEC	0.05	0.04	0.10	0.05					
AE	0.14	0.11	0.27	0.12					
AE-Vineland	0.01	0.01	0.02	0.01					
PS	0.59	0.46	1.10	0.49					
RECO	0.02	0.02	0.04	0.02					
PE	0.60	0.47	1.12	0.50					
FE East-JC	0.32	0.25	0.60	0.27					
PL		0.51	1.23	0.55					
UGI		0.01	0.03	0.01					
FE East-ME		0.18	0.43	0.19					
FE East-PN									
BC				0.44	0.93	3.98	1.48		
PEP				0.35	0.75	3.20	1.19		
PEP-SMECO				0.05	0.10	0.44	0.17		
FE South									
Dom					2.91	4.10	4.62		
Dom-NCEME					0.26	1.11	0.41		
Dom-ODEC					0.05	0.19	0.07		
DLCO									
AEP							1.00		
Dayton									
FE West								0.93	
CPP								0.07	
ComEd									0.998
DEOK									
EKPC									
Rochelle									0.002

IROL Load Shed Procedure

- **Example:** IROL Load Shed Request
 - You multiply the amount of PJM requested relief (350 MW) by your company multiplier (0.49) to get your required Loadshed amount
 - $350 \times 0.49 = 171.5 \text{ MW}$
 - You identify where in your Zone that load will be shed
 - If/When PJM issues the IROL Load Shed Action, you would shed at least 171.5 MW within 5 minutes and keep that amount of load off the system until PJM gives you the OK to restore the load
 - Rotating load is OK so long as the minimum shed is at least 171.5 MW

Interconnection Reliability Operating Limits (IROL) Simulations

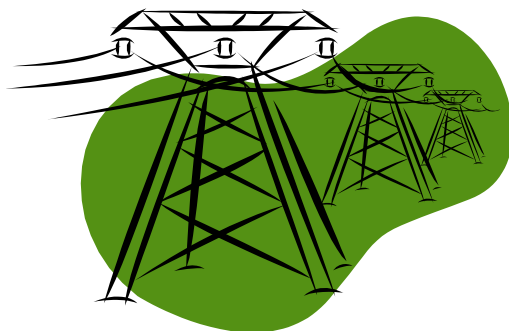

Some Simulation Exercises...

- We are going to look at some Potential IROL Load shedding situations
- For each case, your system will start with actual values within limits
 - A situation will occur causing an IROL violation
 - Your job will be to determine the most efficient way of getting the IROL back within real-time limits



Some Simulation Exercises...

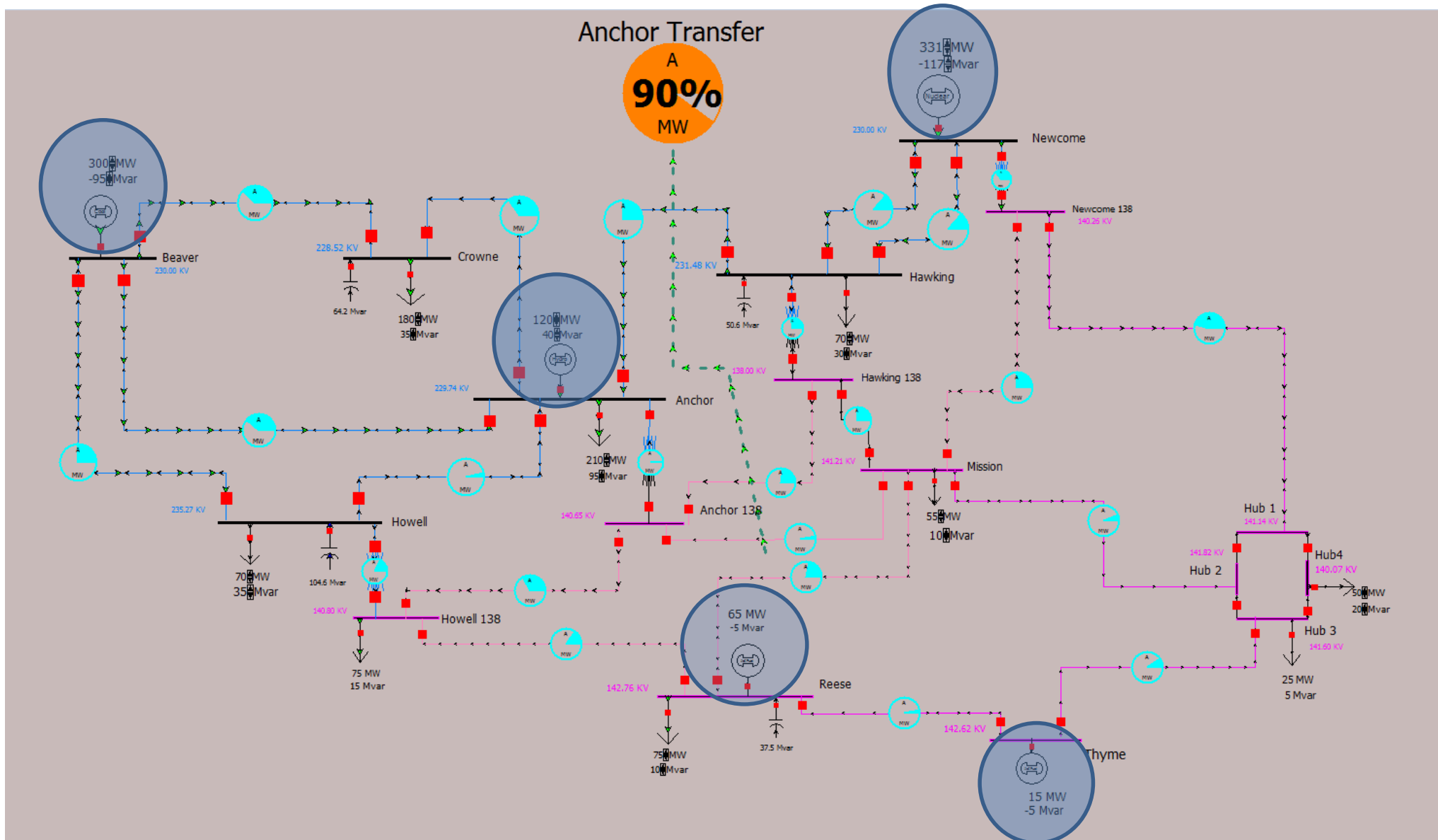

Some Simulation Exercises...

- Maximum Unit output values are:

Beaver - 300 MW Anchor - 200 MW

Newcome - 650 MW Reese -65 MW*

Thyme - 15 MW*

* Reese and Thyme are wind units, and are either full on, or fully off.
Their output is not adjustable

- Newcome is the “slack” unit. It will adjust its output to maintain the system’s ACE as you adjust the output of the other units

Some Simulation Exercises...

- The IROL interface Limit is 120 MW
 - Pie chart at the top of the display shows the percentage of the limit at which the current IROL value is operating
 - For these scenarios we are simply looking at real-time values, not contingency values...
- To see the actual MW value currently across the interface, place the pointer above the IROL line and right click

Some Simulation Exercises...

Interface Dialog

Interface Name: Anchor Transfer

Interface Number: 0

Labels: no labels

Limit A: 120.000
Limit B: 0.000
Limit C: 0.000
Limit D: 0.000
Limit E: 0.000

Monitoring Direction:
 FROM --> TO
 TO --> FROM

Monitor Both Directions

Noncontingent MW Flow Contribution: -108.1
Contingent MW Flow Contribution: 0.0
Total MW Flow: -108.1
PTDF Value (%): 0.00

Interface Elements: OPF Custom

Either: Insert New Element
Clone Elements From Another Interface
or Right-Click to show the Element Dialog

Element Identifiers:
 Name (Number) Name
 Number (Name) Number

	Description	Flow	Weighting	Pre-Weight Flow
1	Line MW flow from bus 'Anchor (3)' to bus 'Hawking (5)' circuit 1	-77.24	1.00	-77.24
2	Line MW flow from bus 'Anchor 138 (6)' to bus 'Hawking 138 (7)' circuit 1	-28.13	1.00	-28.13
3	Line MW flow from bus 'Anchor 138 (6)' to bus 'Mission (8)' circuit 1	-2.76	1.00	-2.76

OK Save Cancel Help Print

Some Simulation Exercises...

- Once the case is open:
 - Ensure Run Mode is selected
 - Left click on the “Tools” tab, then the green button directly below it to start the animation for the simulation

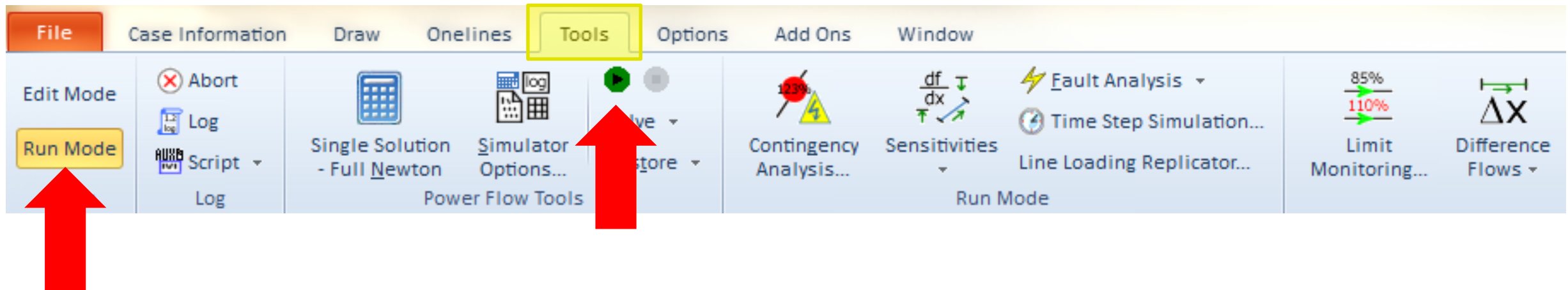

Some Simulation Exercises...

- **Case #1:**

- Once your animation is up and running, here is your situation:

- The wind has died down causing the Wind unit at Reese to come offline. Take the Reese unit offline by clicking on the unit output breaker....

- Answer the questions on the Instructor Screen.....
We will debrief in ~ 5 minutes

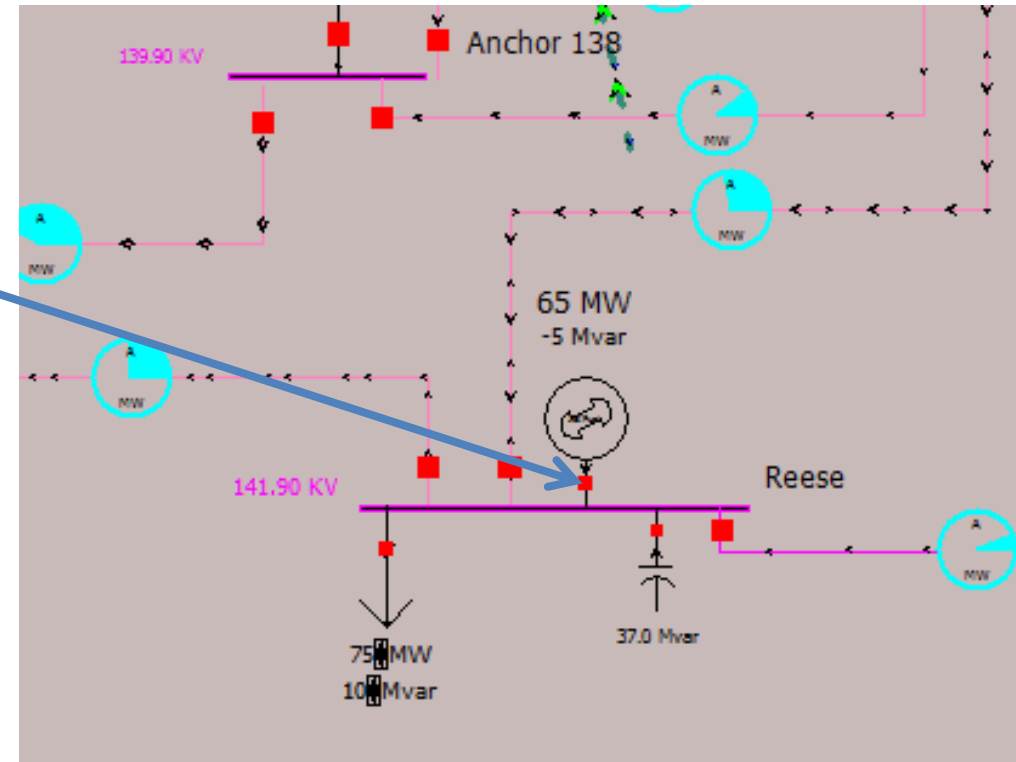

Some Simulation Exercises...

- **Case #1 Questions:**

1. Has taking the Reese Unit offline caused an IROL violation ?
2. If so, by how many MW are you over the IROL limit?
3. For this scenario there are no non-cost options that are effective at controlling the violation. There are no transactions that can be cut that will help. What is your next most desirable option?
4. What course of action do you suggest?
5. How does the action you took compare to the initial violation of the IROL?

Some Simulation Exercises...

- **Case #2:**

- Once your animation is up and running, here is your situation:

- Both Wind units are offline, and will remain offline
- The Mission-Reese 138 kV Line trips out of service. Open the line by clicking on the CB at Either terminal...
- Answer the questions on the Instructor Screen..... We will debrief in ~ 5 minutes

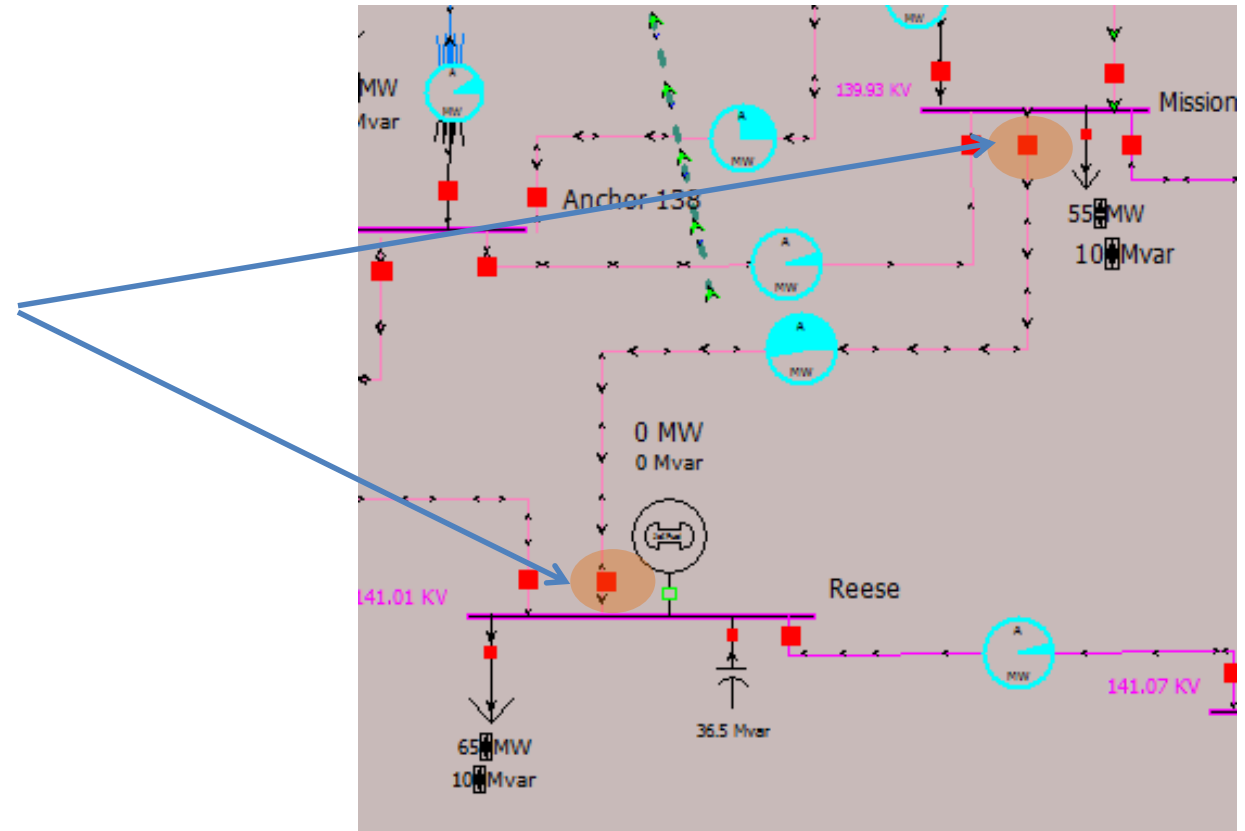

Some Simulation Exercises...

- **Case #2 Questions:**

1. Has the line trip caused an IROL violation ?
2. If so, by how many MW are you over the IROL limit?
3. For this scenario there are no non-cost options. There are no transactions that can be cut that will help. What is your next most desirable option?
4. What course of action do you suggest?
5. Is Generation adjustment sufficient to control the IROL violation?
6. What other action(s) must be taken?

Some Simulation Exercises...

- **Case #3:**

- Once your animation is up and running, here is your situation:

- The Anchor Unit trips offline.
Take the Anchor unit offline by clicking on the unit output breaker...
- Answer the questions on the Instructor Screen.....
We will debrief in ~ 5 minutes.

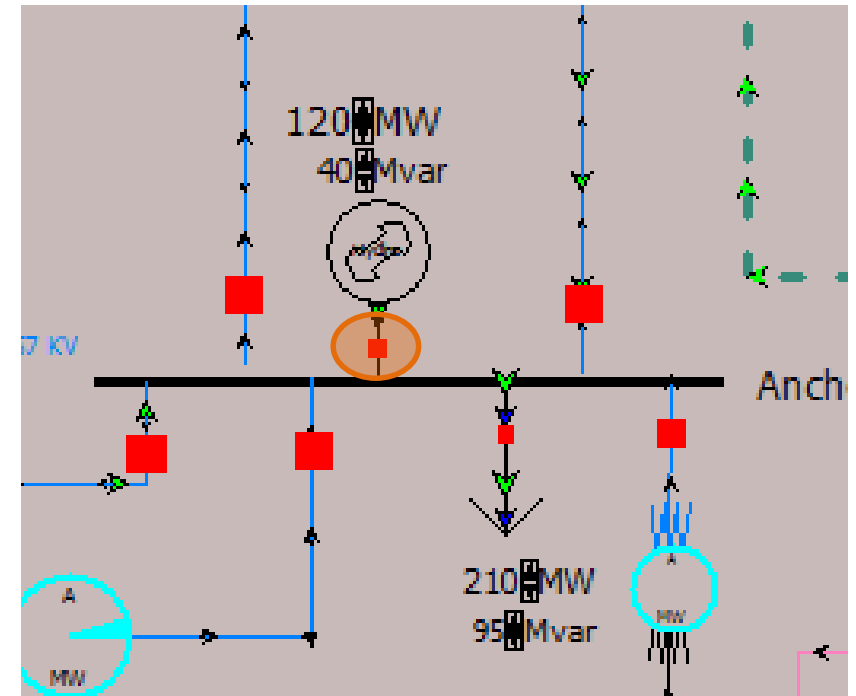

Some Simulation Exercises...

- **Case #3 Questions:**

1. Has the unit trip caused an IROL violation ?
2. If so, by how many MW are you over the IROL limit?
3. For this scenario there are no non-cost options that are effective at controlling the violation. There are no transactions that can be cut that will help. What is your next most desirable option?
4. Consulting your IROL Load shed table, you find out that your multiplier for this interface is 1.2. Using the amount of MW the interface is in violation from #2 above, determine the amount of load you need to shed in the West.
5. Shed that amount of load. Is the interface now within the IROL's?
6. What concept from this module does this example reinforce?

Post Contingency Local Load Relief Warning (PCLLRW)

PCLLRW

Manual 13, Section 5.4

- Purpose: To provide advance notice to Transmission Owners (TOs) of the potential for manual load dump in their area(s)
- Issued after all other means of transmission constraint control have been exhausted or until sufficient generation is on-line within limits/timelines to control the constraint
 - Intended to relieve localized constraints (230kV and below)
 - Implemented as post-contingency violations approach 60 minutes
 - Issued sooner at the request of the Transmission Owner or at the discretion of the PJM Dispatcher

Warning to be communicated to the applicable TO and posted via the Emergency Procedures Posting Application, but not communicated via the “PJM All-Call”

PCLLRW

Manual 13, Section 5.4

- PJM and TO Operator actions:
 - Review contingency flows / limits
 - Discuss off-cost operations/switching solutions prior to implementation of a PCLLRW, system conditions and time permitting
 - Review and implement acceptable pre-contingency switching, load dispatch, and generation redispatch options in lieu of issuing a Post-Contingency Local Load Relief Warning

Note: If post contingency flows exceed the Load Dump rating, PJM will direct the Transmission Owner to implement any available switching solutions, provided they do not create any additional actual overloads in exceedance of their normal rating or post-contingency overloads

PCLLRW

Manual 13, Section 5.4

- PJM dispatcher actions:
 - Commit/de-commits effective generation
 - Adjust hydro/pumping schedules
 - Curtail interchange transactions
 - Commit quick-start generation
 - Market to market re-dispatch implemented where applicable

Note: As indicated in M-12, for “Reliability Only” facilities (i.e. facilities not under PJM Congestion Management) the Transmission Owners have the option to pay for generation redispatch on a pre-contingency basis or accept a PCLLRW. However, if a “Reliability Only” facility exceeds its Load Dump rating, PJM will manually dispatch generation to maintain flows below the Load Dump rating

PCLLRW

Manual 13, Section 5.4

- PJM dispatcher actions:
 - Determine desired flow on affected facility
 - Post-contingency flow < LTE rating
 - Issue PCLLRW
 - Communicate verbally to affected TO(s)
 - Post on Emergency Procedure Posting Application
 - Include area affected, desired flow, any post-contingency switching, generation reductions or load transfer options
 - Email load Dfax report to affected TO(s)

PCLLRW

Manual 13, Section 5.4

- PJM dispatcher actions:
 - Establish mutual awareness with appropriate TO of the need to address the post-contingency actions with minimal delay
 - Direct load shed should contingency occur
 - Cancel PCLLRW when appropriate
 - Post-contingency flow drops below LTE rating and is not expected to reappear in the near future
 - Notify TO prior to canceling PCLLRW
 - Cancel in Emergency Procedure application
 - Log

PCLLRW

Manual 13, Section 5.4

- Member Actions:
 - Update load shedding plan in PCLLRW eTool application
 - Monitor expected post-contingency flows and adjust load dump strategy as appropriate
 - Advise appropriate stations and key personnel
 - Staff substations as necessary if load shed can't be accomplished via SCADA
 - Review load dump procedures and prepare to dump load in amount requested when directed by PJM

PCLLRW

Manual 13, Section 5.4

- Member Actions:
 - Prepare to implement post-contingency switching options, manual generation trip or SCADA load transfer
 - Prepare to implement load shedding if above fails
 - Man substations if SCADA fails or is insufficient
 - Notify PJM if post-contingency flow drops below LTE limit and PCLLRW has not yet been cancelled

Implementation of PCLLRW

When to Issue a PCLLRW?

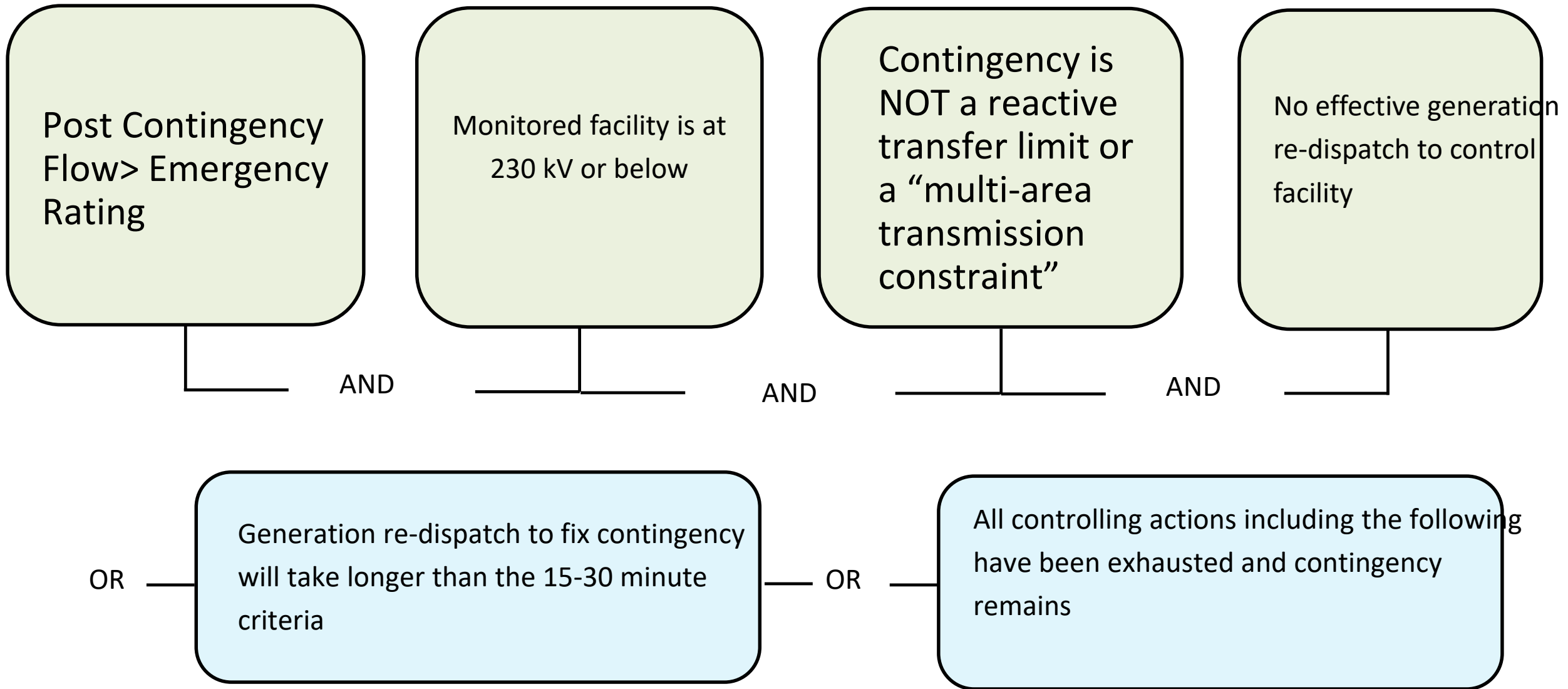

Posting of PCLLRWs

Postings

Postings Message Definitions Message Priorities Regions Emergency Bid Form

From * 05/03/2015 To * 05/05/2015 Regions Message Types PJM Drill Include Active Only Reset



Last Updated: 05.05.2015 15:54:16 Filters: 05/03/2015 to 05/05/2015; Include PJM Drill

Records Per Page: 15 (1 of 1)

History	Msg ID	Priority	Message Type	Posting Timestamp	Regions	Emergency Message	Cancellation Timestamp
	100202	Warning	Post Contingency Local Load Relief Warning	05.05.2015 15:54	DEOK	As of 15:52 on 05.05.2015 a Post Contingency Local Load Relief Warning to maintain 08CRSNT1-WENDCIN 1587 at 253 MVA in the DEOK area has been issued for Transmission Contingency Control. Additional Comments: Load -No Generation or Switching available	
	100201	Warning	Post Contingency Local Load Relief Warning	05.05.2015 11:50	PPL	As of 11:46 on 05.05.2015 a Post Contingency Local Load Relief Warning to maintain WESCOSVI 2 XFORMER at 257 MVA in the PPL area has been issued for Transmission Contingency Control. Additional Comments: Post Contingency Switching available	
	100200	Warning	Post Contingency Local Load Relief Warning	05.05.2015 10:04	EKPC	As of 09:58 on 05.05.2015 a Post Contingency Local Load Relief Warning to maintain CNTRLHAR 138 KV at 127 KV in the EKPC area has been issued for Transmission Contingency Control. Additional Comments: Post Contingency Switching available	

PCLLRW Tool Access

The screenshot displays the eSUITE web application interface. On the left is a vertical navigation menu with the following items: > eMKT, > eRPM, > ExSchedule, > Gas Pipeline, > InSchedule, > Member Commu (with a Login button), > Messages, > MSRS, > OASIS, > Post Contingency Local Load Relief Warning (highlighted with a red box), > Power Meter, > Resource Tracker, > Voting, and a grey bar for Non - eSuite Tools. The main content area features the eSUITE logo at the top left, followed by the heading 'PJM Tools'. Below this heading is a paragraph describing the tools: 'PJM Interconnection's tools are a group of sophisticated Internet-based software applications that allow members to transact much of their business online. Using PJM's tools gives members real-time data about the electric system. They can buy and sell power, arrange transmission service, schedule contract purchases, carry out business strategies and make critical business decisions.' Below the paragraph are three links: [System Requirements](#), [Sandbox Registration Procedures](#), and [Frequently Asked Questions](#). At the top right of the main area are links for '> Logout' and '> E-mail'. On the right side of the page, there are three distinct sections: 'Customer Support' with contact information (610-666-8980 or 866-400-8980), 'My Account' with a 'My Account' button, 'Tool Documentation' with a 'Go to...' dropdown menu, and 'New Users Registration' with a 'New User' button. An arrow points from the text 'Select "Post Contingency Local Load Relief Warning"' to the highlighted menu item.

> Logout > E-mail

Customer Support
If you have any questions, please call the Member Relations Hotline at 610-666-8980 or 866-400-8980.

My Account
Change my password, edit my information and view my account history.
[My Account](#)

Tool Documentation
PJM offers information about its tools, including user guides, manuals and frequently asked questions (FAQ). Each tool's page has links to detailed information about that tool.
Go to...

New Users Registration
Startup form for first-time Tools Participant Company (primary account) - use "CAM Form A" [Participant Authorization Form](#) (Required Once)
Startup form for Non-Participant Company seeking access to Power Contracts Bulletin Board - use "CAM Form A-1" [Bulletin Board Authorization Form](#) (Required Once)
Startup and subsequent changes to designation of CAM(s) and additional tools access - use "CAM Form B" [CAM Designation Form](#) (Required For Each Request)
[New User](#)

Select "Post Contingency Local Load Relief Warning"

TO PCLLRW Application View

Branch ID ↓ Contingency Information ↓ Limits Information ↓ Contingency Title ↓ Status ↓

Thermal PCLLRW Information													
Co	Branch ID	KV	Pre MVA	Post MVA	NL	LT	ST	LD	MVA	(%)	MP	Contingency Title	Status
AEP	LAPORTE-MICHIGA2 NIP TIE	138	107	182	172	172	191	191	-8	106	1	L765.Dumont-Wilton Center.11215	
CPP	CPP_EAST-POFOK EAS-HOLT	138	142	228	194	237	237	273					
APS	BUTL APS-KARNSCIT KC-BT	138	98	179	168	190	190	198					
AEP	CLOVERD2 . 10 XFORMER	765	1496	1743	1680	1859	1859	2045					
AEP	KAMMER-NATRIUM	138	144	253	218	270	270	278					
AEP	CLAYBURN-ROSS	138	114	153	166	167	167	167					
AEP	MARYSVI2-TANGY TIE	345	552	915	1000	1000	1000	1000					
COMED	55 HEGEW-17714 17714 2	138	148	311	316	343	392	461					
COMED	156 CHERRY 38TR82 CT	138	289	414	400	465	514	530					
APS	CRUPPERN-NETTIE 162	138	123	156	146	174	174	196	-17	89		L500.Cloverdale-Lexington.566	

(1 of 4) 1 2 3 4 10

Option to change number of contingencies shown in a window

- Choose 10, 20 or 50

Special Thermal PCLLRW Information													
Co	Branch ID	KV	Pre MVA	Post MVA	NL	LT	ST	LD	MVA	(%)	MP	Contingency Title	Status
AEP	LAPORTE-MICHIGA2 NIP TIE											ED) (NIP5)	
AEP	NEWCOMER-SCOSHOC NEW-SCO											IZE	
AEP	BUCKHORN-TAZEWEILL											IZE	
AEP	CLAYBURN-ROSS											ScnIz)	

Contingencies are listed with *most severe at top*

- As analysis continues, PCLLRW may move further down list or to another page

Low Voltage PCLLRW Information													
Co	Bus ID	Pre (KV)	Post (KV)	NL	EM	LD	Under (KV)	% of EM/LD	MP	Contingency Title	Status		
AEP	REYNOLD2 138 KV BB_17299	136.9	126.3	131.1	127.0	124.2	0.7	99.5	2	L230.Cayuga-Veegersburg			
PS	WARDAV 138 KV *F02	138.7	130.9	135.0	131.0	124.0	0.1	99.9	2	L138.Trenton-Yardville.WardAve.K1363			
PS	CROSSWIC 138 KV *F08	138.9	131.4	135.0	131.0	124.0	-0.4	100.3	1	L138.Trenton-Yardville.WardAve.K1363			
PN	SHAWVILL 115 KV 115-2	117.8	106.7	109.0	106.0	103.0	-0.7	100.7	1	Shawville #2 unit			
AEP	DEWEY 138 KV BB_773	138.5	130.3	131.1	127.0	124.2	-3.4	102.6	2	L138.MorganFork-HaysBranch			
AEP	THELMA 138 KV BB_2193	138.1	130.4	131.1	127.0	124.2	-3.4	102.7	2	L138.MorganFork-HaysBranch			

PCLLRW Status

Status

<u>Unacknowledged</u>

Unacknowledged – *TO hasn't responded to PCLLRW*

Deficient – *Load Shed plan is not enough to meet the PCLLRW.*

<u>Deficient</u>

Valid – *Load shed plan is sufficient to meet the PCLLRW*

Changing system conditions can cause a **Valid** load shed plan status to change to **Deficient**

- 5 MVA Bandwidth +/-

<u>Valid</u>

TO Load Shed Plan Display

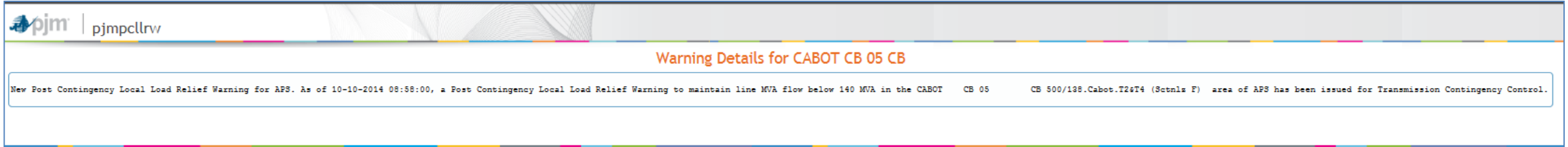

The screenshot shows a header with the PJM logo and 'pjmpcllrw'. Below it is a title bar 'Warning Details for CABOT CB 05 CB'. The main content area contains a warning message: 'New Post Contingency Local Load Relief Warning for APS. As of 10-10-2014 08:58:00, a Post Contingency Local Load Relief Warning to maintain line MVA flow below 140 MVA in the CABOT CB 05 CB 500/138.Cabot.T2&T4 (Scnlz F) area of APS has been issued for Transmission Contingency Control.'

Clicking on “Unacknowledged” opens the Load Shed Plan for the specific PCLLRW

- TO must still identify locations and amount of planned load shed should Load Shed Directive be issued

TO Load Shed Plan Display

Current Post Contingency Local load Relief Warnings

Last SA Timestamp: 10/10/2014 09:33:00

Thermal PCLLRW Information													Contingency Title	Status
Co	Branch ID	KV	Pre MVA	Post MVA	NL	LT	ST	LD	MVA	(%)	MP			
APS	CABOT CB 05 CB	500	427	634	130	135	140	145	494	469	1	L500.South Bend-Yukon		
PS	BERGEN F-1306 CB	138	98	139	60	80	80	85	59	174	1	L138.Bergen-East Rutherford.R-1344		
PS	49STREET-HOBOKEN R-2270-3	230	355	466	200	200	225	986	241	233	1	L138.Marion-Homestead-NorthBergen-Bergen.E-1305		
COMED	55 HEGEW-17714 17714 2	138	175	330	316	343	392	461	-61	96	1	L345.Burnham-Sheffield.17705 TIE		
BC	BAGLEY - GRACETON 2304	230	426	665	587	703	703	703	-37	94	1	L500.Brighton-Conastone		
PE	EMILIE STR XFORMER	230	258	427	341	453	453	515	-25	94	1	230/138.Emilie.7TR		
COMED	7713 -981 CRES 7713 2	138	110	164	174	174	174	185	-9	94	1	L345.Nelson-Electric Junction.15502		
APS	ALLDAM6-KITTANNI SP-KT	138	47	144	159	159	159	178	-14	91	1	L345.Armstrong-HomerCity		
COMED	0905 LINE 38L0905 10	138	151	175	175	195	195	201	-19	89	2	345L11124 Electric Jct-Lombard 345 kv Line		
BC	BAGLEY -RAPHAERD BAO-RAP	230	387	626	587	703	703	703	-76	89	1	L500.Brighton-Conastone		

(1 of 5) 1 2 3 4 5 10

Special Thermal PCLLRW Information													Contingency Title	Status
Co	Branch ID	KV	Pre MVA	Post MVA	NL	LT	ST	LD	MVA	(%)	MP			
APS	CABOT CB 05 CB	500	427	823	130	135	140	145	683	610	1	500/138.Cabot.T2&T4 (Sctniz F)	Unacknowledged	
COMED	0905 LINE 38L0905 10	138	151	181	175	195	195	201	-13	92	2	345L11602 5F Goodings Grove-E Frank 345kv SPOG3-29		

(1 of 1) 1 10

Low Voltage PCLLRW Information													Contingency Title	Status
Co	Bus ID	Pre (KV)	Post (KV)	NL	EM	LD	Under (KV)	% of EM/LD	MP					
AEP	REYNOLD2 138 KV BB_17299	136.9	109.8	131.1	127.0	124.2	14.4	88.4	2	MeadowLake-Reynolds-Olive 345kv & Reynolds Xfmr				
COMED	176 STIL 138 KV BB_10	138.4	125.6	131.1	127.0	124.2	1.4	98.9	1	L345.Nelson-Electric Junction.15502				
COMED	937 LEE 138 KV BB_16	132.2	127.1	131.1	127.0	124.2	-0.1	100.0	2	6 Byron.U1				
COMED	959ERDB5 138 KV BB_3	134.6	128.2	131.1	127.0	124.2	-1.2	101.0	2	6 Byron.U1				
AEP	HUFFMAN 138 KV BB_5792	141.9	129.0	131.1	127.0	124.2	-2.0	101.6	2	L138.Jac				
AEP	PIPERSQA 138 KV BB_6325	141.7	129.2	131.1	127.0	124.2	-2.2	101.7	2	L138.Ja				
AEP	INDUSTRY 138 KV BB_3139	140.0	129.6	131.1	127.0	124.2	-2.7	102.1	2	L138.N				
AEP	HOW 138 KV BB_3120	140.1	129.8	131.1	127.0	124.2	-2.8	102.2	2	L138.N				
FE	O2ARMCO 138 KV *E08	134.7	129.8	131.1	127.0	124.2	-2.8	102.2	1	345/13				
PN	CORRYE 115 KV 115-2	114.0	108.3	109.0	106.0	103.0	-2.3	102.2	1	L230.O				

(1 of 5) 1 2 3 4 5 10

Special Low Voltage PCLLRW Information													Contingency Title	Status
Co	Bus ID	Pre (KV)	Post (KV)	NL	EM	LD	Under (KV)	% of EM/LD	MP					
AEP	CLOVERD2 765 KV *A05	776.1	708.7	726.8	703.8	688.5	-4.9	100.7	1	765/345.Cloverdale.T.10 FAILED SECTIONALIZE				
AEP	BOXWOOD 138 KV BB_5097	137.8	128.1	131.1	127.0	124.2	-1.1	100.9	2	765/345.Cloverdale.T.10 FAILED SECTIONALIZE				
AEP	IVYHILL 138 KV BB_5867	139.2	128.2	131.1	127.0	124.2	-1.3	101.0	2	765/345.Cloverdale.T.10 FAILED SECTIONALIZE				
AEP	CENTRVIL 138 KV BB_5242	138.7	128.2	131.1	127.0	124.2	-1.3	101.0	2	765/345.Cloverdale.T.10 FAILED SECTIONALIZE				
AEP	COFFEE 138 KV *E02	138.8	128.3	131.1	127.0	124.2	-1.3	101.0	2	765/345.Cloverdale.T.10 FAILED SECTIONALIZE				

Unacknowledged PCLLRW

TO Load Shed Plan Display

- The required MW amount to relieve the PCLLRW will be listed
- As data is entered, the Cumulative Load Shed Relief will update
 - This box is highlighted **red** until the desired amount has been reached
 - The box will change to **green** when the desired amount is reached
- When the TO is satisfied with the report, select “Confirm Load Plan” button to submit to PJM

TO Load Shed Plan

- The required MW amount to relieve the PCLLRW will be listed

Load Reduction Megawatt Amount Needed	19
---------------------------------------	----

- As data is entered, the Cumulative Load Shed Relief will update

Cumulative Load Shed Relief	0
-----------------------------	---

- Highlighted **red** until desired amount has been reached
- Box then changes to **green**

- When the TO is satisfied with the report, select “Confirm Load Plan” button to submit to PJM

Confirm Load Plan	Cancel
-------------------	--------

TO Load Shed Plan Display

Warning Details for STORONT2 1 XFORMER

Time remaining: 03:44 [Reset](#)

The following are the distribution factors which affect STORONT2 1 XFORMER:
 Actual MVA : 27 Contingency MVA : 62
 When the following facilities are outaged: (Contingency #20980)

0.674	STEBENV-TIDD_AEP 138 KV	Flow	50.3
-0.674	STEBENV_LOADIF_XFORMER 69 KV	Flow	0

Reason: Post Contingency Switching available

PJM Note: NA

Zone	Station	Name	Distribution Factor	Load Reduction Megawatt Amount Needed		Load Shed Relief MW
				PJM SE Station Load MW	Transmission Owner Projected Load Shed	
AEP-O	WTORONT	T1	0.6145	0	0	0
AEP-O	HAMMOND	T1	0.3668	2	0	0
AEP-O	HAMMOND	T2	0.3668	0	0	0
AEP-O	18THSTH	T1	0.322	2	0	0
APSS	AIRCO	T2	0.0148	15	0	0
AEP-O	PANDARD	CARROLL	0.0116	7	0	0
APSS	WEIRTON	T3	-0.0107	0	0	0
AEP-O	SALTFOR	SALT	0.0075	3	0	0
AEP-O	MALVERH	T3	0.0074	33	0	0
AEP-O	MALVERH	T1	0.0074	4	0	0
AEP-O	BROOMRD	LOAD1	0.0072	10	0	0
AEP-O	LEATHERV	NCAMBRID	0.0071	3	0	0
AEP-O	ECAMBRID	LOAD1	0.0068	15	0	0
APSS	SMT APS	T3	-0.0059	0	0	0
AEP-O	WNEVPHIL	T3	0.005	4	0	0
AEP-O	HILLVIEW	T1	0.0049	8	0	0
AEP-O	CODOVER	T1	0.0044	18	0	0
AEP-O	CODOVER	T2	0.0044	1	0	0
AEP-O	SUNNYSOP	T5	0.0044	17	0	0
AEP-O	SUNNYSOP	T6	0.0044	10	0	0
AEP-O	SUNNYSOP	T4	0.0044	12	0	0
AEP-O	WARNERS	ALLOYS	0.0043	10	0	0
APSS	WIND APS	T1	-0.0039	-2	0	0
Cumulative Load Shed Relief					17	

This PCLLRW has an FLS program associated with it.
 Amount:

This PCLLRW has a switching solution associated with it.
 Amount:

[Confirm Load Plan](#) [Cancel](#)

Required Relief

**Actual Relief
(RED is deficient)**

**Use if TO has
FLS program**

**or Switching
Solution is
available**

**Click
to submit
to PJM**

TO Load Shed Plan Display

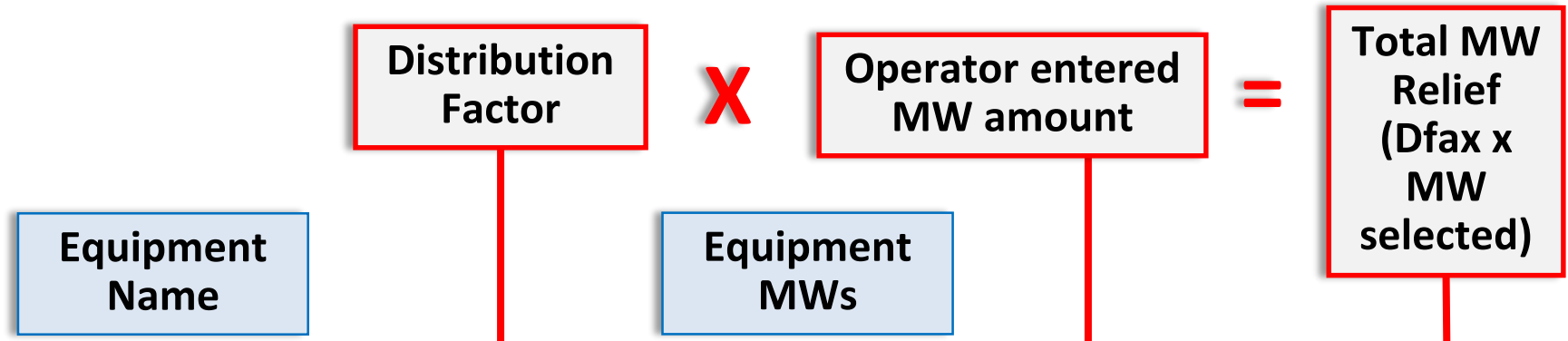

				Load Reduction MegaWatt Amount Needed	62	
Zone	Station	Name	Distribution Factor	PJM SE Station Load MW	Transmission Owner Projected Load Shed	Load Shed Relief MW
AEP	TORREY	T4	0.6623	36	<input type="text" value="33"/>	22
AEP	REEDURBA	T2	0.6154	13	<input type="text" value="12"/>	7
AEP	REEDURBA	T1	0.6154	12	<input type="text" value="11"/>	7
AEP	MILESAVE	T1	0.5914	12	<input type="text" value="11"/>	7
AEP	WCANTON	T3	0.5554	4	<input type="text" value="0"/>	0
FE	DALEOE	TR2	0.2733	1	<input type="text" value="0"/>	0
FE	CLOVEROE	B	0.2611	46	<input type="text" value="0"/>	0
FE	CLOVEROE	A	0.256	50	<input type="text" value="0"/>	0
FE	DALEOE	B	0.2185	87	<input type="text" value="0"/>	0
FE	MOOREOE	TR1	0.1959	13	<input type="text" value="0"/>	0

TO Load Shed Plan Deficient

- If a submitted TO Load Shed is deficient:
 - A warning message received indicating such
 - Adjust load shed to satisfy needed amount

0.0001	13
<div data-bbox="1156 479 2346 886"><p>Insufficient Load Shed Values</p><p>The load shed values do not meet the desired reduction. Are you sure you want to submit this plan?</p><p>Yes</p></div>	
0.0001	18
0.0001	11

PCLLRW - Multiple Zones

Multiple Zones, Manual 13:

- PCLLRW is issued to TO of overloaded equipment
 - Enough load must be shed to maintain flows on the monitored facility below the Emergency Rating or an agreed upon level
 - If sufficient load is not available to shed or sufficient time to shed is not adequate
 - TO shall inform PJM so they to include neighboring TO loads if applicable or develop an alternative plan to control

Note: If all of the load to be shed is in the non-owning Transmission Owner's territory, PJM may issue the PCLLRW to the Transmission Owner with the load and not the Transmission Owner of the limiting equipment. However, PJM will inform/coordinate the post contingency load shed plan with the Transmission Owner of the equipment

PCLLRW - Multiple Zones

- The tool will create TWO emails w/ the DFAX and send APS and AEP each a copy of the DFAX
- The DFAX and SA alarm will show up on BOTH company's PCLLRW tool screens:

Browser: pjmpcllrw - Current SA Violations
 URL: https://pjmpcllrw.ac1stage.pjm.com/pjmpcllrw/pages/secure/sa-violations.jsf
 My Tools | AP | Allegheny Power (for WPenn, MonPwr, PotEd) (BRENTAP) | Sign Out | Contact | Help

Current SA Violation Listing

Last SA Timestamp: 03/02/2015 15:23:00

Thermal PCLLRW Information													
Co	Branch ID	KV	Pre MVA	Post MVA	NL	LT	ST	LD	MVA	(%)	MP	Contingency Title	Status
No records found.													
(1 of 1) < << >> > 10 ▼													

Special Thermal PCLLRW Information													
Co	Branch ID	KV	Pre MVA	Post MVA	NL	LT	ST	LD	MVA	(%)	MP	Contingency Title	Status
APS	BELMONT TRAN 3 XFORMER	500	204	523	525	595	595	685	-71	87	1	500/138.Belmont.T1&T2	<u>Unacknowledged</u>
(1 of 1) < << 1 >> > 10 ▼													

Low Voltage PCLLRW Information												
Co	Bus ID	Pre (KV)	Post (KV)	NL	EM	LD	Under (KV)	% of EM/LD	MP	Contingency Title	Status	
No records found.												
(1 of 1) < << >> > 10 ▼												

Special Low Voltage PCLLRW Information												
Co	Bus ID	Pre (KV)	Post (KV)	NL	EM	LD	Under (KV)	% of EM/LD	MP	Contingency Title	Status	
No records found.												
(1 of 1) < << >> > 10 ▼												

PCLLRW - Multiple Zones

- Here's the AEP PCLLRW screen. Notice the APS SA violation is there.
- Both TOs can contribute to the load shed plan; however, only one at a time can edit it

Browser tabs: pjmpcllrw - Current SA Violations, New Tab

Address bar: https://pjmpcllrw.ac1stage.pjm.com/pjmpcllrw/pages/secure/sa-violations.jsf

Page Header: My Tools | AEP SCT | Appalachian Power Company (AEP Transmission) (BRENTAEPI) | Sign Out | Contact | Help

Logo: pjm | pjmpcllrw

Current SA Violation Listing

Last SA Timestamp: 03/02/2015 15:14:00

Thermal PCLLRW Information													
Co	Branch ID	KV	Pre MVA	Post MVA	NL	LT	ST	LD	MVA	(%)	MP	Contingency Title	Status
No records found.													
(1 of 1) [Navigation] 10													

Special Thermal PCLLRW Information													
Co	Branch ID	KV	Pre MVA	Post MVA	NL	LT	ST	LD	MVA	(%)	MP	Contingency Title	Status
APS	BELMONT TRAN 3 XFORMER	500	204	521	525	595	595	685	--73	87	1	500/138.Belmont.T1&T2	<u>Unacknowledged</u>
(1 of 1) [Navigation] 10													

Low Voltage PCLLRW Information													
Co	Bus ID	Pre (KV)	Post (KV)	NL	EM	LD	Under (KV)	% of EM/LD	MP	Contingency Title	Status		
AEP	ENEWCNC 138 KV BB_11547	142.4	130.7	131.1	127.0	124.2	-3.7	102.9	1	L138.Newcomerstown-W.Cambridge			
AEP	WCAMBRI2 138 KV BB_12408	142.4	130.7	131.1	127.0	124.2	-3.7	102.9	2	L138.Newcomerstown-W.Cambridge			
(1 of 1) [Navigation] 10													

Special Low Voltage PCLLRW Information													
Co	Bus ID	Pre (KV)	Post (KV)	NL	EM	LD	Under (KV)	% of EM/LD	MP	Contingency Title	Status		
No records found.													
(1 of 1) [Navigation] 10													

PCLLRW - Multiple Zones

If a TO tries to edit the PCLLRW while another is working on it, they will see the following:

Notice, the Box: **“Another user is editing this Load Shed Plan”**

The **“Transmission Owner Projected Load Shed”** column cannot be edited

The screenshot shows the PJM PCLLRW interface. At the top, there is a navigation bar with 'My Tools', 'pjm | pjmpcllrw', and user information. A warning message is displayed: 'Warning Details for BELMONT TRAN 3 XFORMER' with a sub-message 'Another user is editing this Load Shed Plan.' and an 'Edit' button. Below the warning, there is a section for distribution factors for BELMONT TRAN 3 XFORMER, including Actual MVA (206.2) and Contingency MVA (525.5). A table lists distribution factors for various stations and zones. A red box highlights the 'Transmission Owner Projected Load Shed' column, which contains the value '0' for all rows.

Zone	Station	Name	Distribution Factor	Load Reduction MegaWatt Amount Needed		
				PJM SE Station Load MW	Transmission Owner Projected Load Shed	Load Shed Relief MW
APSS	ROCHEVIT	T1	0.7105	11	0	0
APSS	WAVERLY	T2	0.7044	14	0	0
APSS	FLATIRON	T1-2	0.7032	3	0	0
APSS	METZ	T1	0.7032	3	0	0
APSS	MOBLEY	LOAD1	0.7032	52	0	0
APSS	JACKSONB	HOPEHAST	0.7032	32	0	0
APSS	JACKSONB	T1	0.7032	5	0	0
APSS	MIDDLEBO	T1	0.7032	5	0	0
AEP	RENO	T1	0.7005	1	0	0
APSS	EUREKA	T1	0.7002	2	0	0
APSS	PLEASNT	LD_2	0.6996	2	0	0
APSS	PLEASNT	LD_1	0.6996	2	0	0
APSS	WILLMCRK	T2	0.6982	1	0	0
AEP	DUCKCREE	T1	0.697	13	0	0
AEP	MILL AEP	T2	0.6958	6	0	0
AEP	MILL AEP	T3	0.6958	8	0	0
AEP	MILL AEP	T4	0.6958	9	0	0

PCLLRW - Multiple Zones

The editing TO gets 5 minutes (but can be reset and add more time if needed)

Note: the form **DOES NOT ENFORCE** TOs changing or accidentally putting data in the wrong row
 In this example, APS could enter numbers for AEP and vice-versa

Warning Details for BELMONT TRAN 3 XFORMER

The following are the distribution factors which affect BELMONT TRAN 3 XFORMER:
 Actual MVA : 206.2 Contingency MVA : 525.5
 When the following facilities are outaged: (Contingency #13730)

-0.4095	BELMONT TRAN 1 XFORMER 138 KV	Flow	-186.5
-0.7577	BELMONT TRAN 2 XFORMER 138 KV	Flow	-315.6

Reason: Post Contingency Switching available



PJM Note
NA

Time remaining: 02:39 [Reset](#)

Zone	Station	Name	Distribution Factor	Load Reduction MegaWatt Amount Needed		Load Shed Relief MW
				PJM SE Station Load MW	Transmission Owner Projected Load Shed	
APSS	ROCHEVIT	T1	0.7105	11	11	8
APSS	WAVERLY	T2	0.7044	14	14	10
APSS	FLATRUN	T1-2	0.7032	3	0	0
APSS	METZ	T1	0.7032	3	0	0
APSS	MOBLEY	LOAD1	0.7032	52	0	0
APSS	JACKSONB	HOPEHAST	0.7032	32	0	0
APSS	JACKSONB	T1	0.7032	5	0	0
APSS	MIDDLEBO	T1	0.7032	5	0	0
AEP	REHO	T1	0.7005	1	0	0
APSS	EUREKA	T1	0.7002	2	0	0
APSS	PLEASNT	LD_2	0.6996	2	0	0
APSS	PLEASNT	LD_1	0.6996	2	0	0
APSS	WILLACRK	T2	0.6982	1	0	0
AEP	DUCKCREE	T1	0.697	13	0	0
AEP	MILL AEP	T2	0.6958	6	0	0
AEP	MILL AEP	T3	0.6958	8	0	0
AEP	MILL AEP	T4	0.6958	9	0	0
AEP	MILL AEP	T1	0.6958	6	0	0
AEP	GOODRICH	T1	0.6952	1	0	0
AEP	HARMARHI	T1	0.6939	7	0	0
APSS	NYIENNA	T1	0.692	0	0	0
APSS	JOHNSMAN	T1	0.6912	3	0	0

PCLLRW - Multiple Zones

- The system sends two emails, one to each TO

	PCLLRW	New Post Contingency Local Load Relief Warning for Western. As of 03/02/2015 15:07:00 a new Post Contingency Local Load Relief Warning issued to control BELMONT TRAN 3 XF...	Mon 3/2/2015 3:10 PM
	PCLLRW	New Post Contingency Local Load Relief Warning for Western. As of 03/02/2015 15:07:00 a new Post Contingency Local Load Relief Warning issued to control BELMONT TRAN 3 XF...	Mon 3/2/2015 3:10 PM

PCLLRW - Multiple Zones

- Single posting in Emergency Procedures

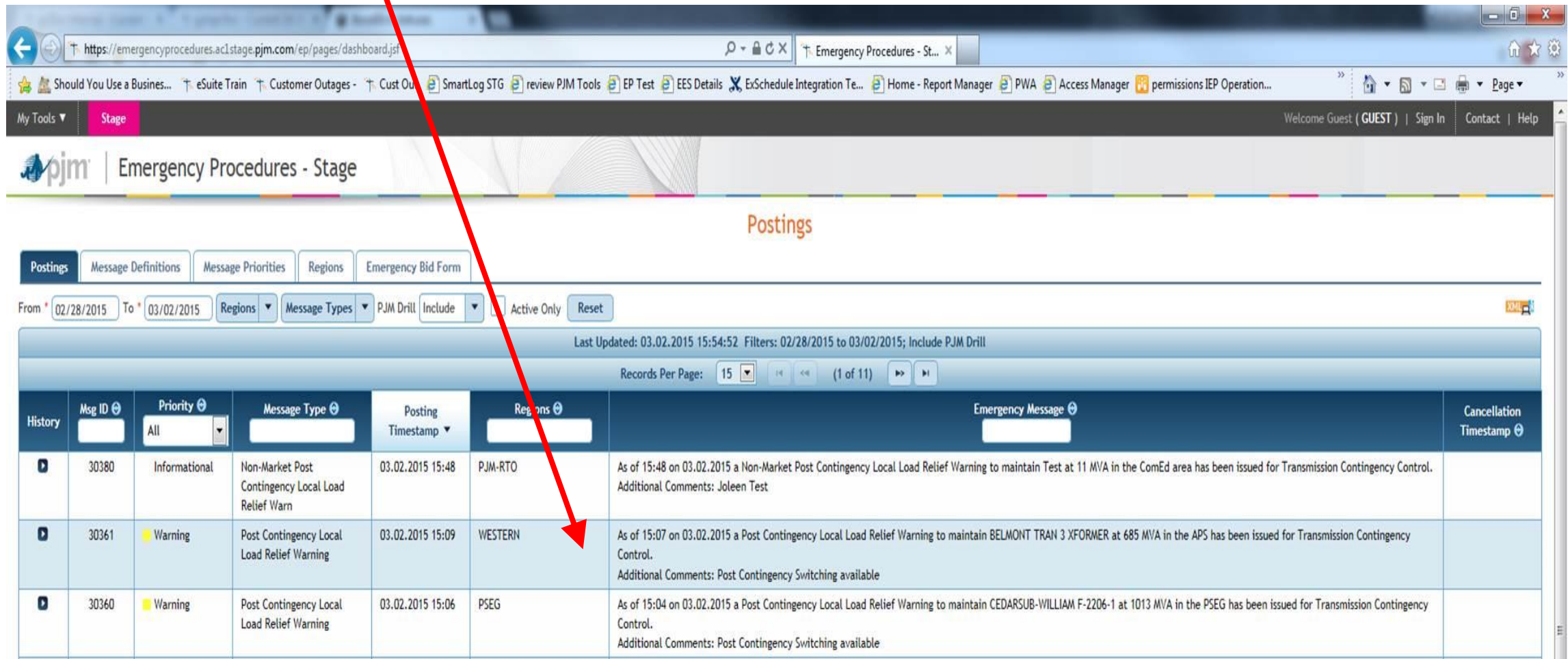

The screenshot displays the 'Emergency Procedures - Stage' web application. The page title is 'Postings'. Below the title, there are navigation tabs: 'Postings', 'Message Definitions', 'Message Priorities', 'Regions', and 'Emergency Bid Form'. The 'Postings' tab is active. The page shows a search filter for 'From' 02/28/2015 to 'To' 03/02/2015, with 'Message Types' set to 'PJM Drill' and 'Include' checked. The table below shows a list of postings with columns for History, Msg ID, Priority, Message Type, Posting Timestamp, Regions, Emergency Message, and Cancellation Timestamp. A red arrow points to the 'WESTERN' region in the second row of the table.

History	Msg ID	Priority	Message Type	Posting Timestamp	Regions	Emergency Message	Cancellation Timestamp
	30380	Informational	Non-Market Post Contingency Local Load Relief Warn	03.02.2015 15:48	PJM-RTO	As of 15:48 on 03.02.2015 a Non-Market Post Contingency Local Load Relief Warning to maintain Test at 11 MVA in the ComEd area has been issued for Transmission Contingency Control. Additional Comments: Joleen Test	
	30361	Warning	Post Contingency Local Load Relief Warning	03.02.2015 15:09	WESTERN	As of 15:07 on 03.02.2015 a Post Contingency Local Load Relief Warning to maintain BELMONT TRAN 3 XFORMER at 685 MVA in the APS has been issued for Transmission Contingency Control. Additional Comments: Post Contingency Switching available	
	30360	Warning	Post Contingency Local Load Relief Warning	03.02.2015 15:06	PSEG	As of 15:04 on 03.02.2015 a Post Contingency Local Load Relief Warning to maintain CEDARSUB-WILLIAM F-2206-1 at 1013 MVA in the PSEG has been issued for Transmission Contingency Control. Additional Comments: Post Contingency Switching available	

Post Contingency Load Dump Limit Exceedance Analysis

Post-Contingency Load Dump Limit Exceedance Analysis

Manual 13, Section 5.4.1

- NERC Standard PRC-023 R1.2 and R1.11
 - Transmission line relays and transformer overload protection relays are set so they do not operate at or below 115% of the facility's highest emergency rating
- PJM facilities highest rating is the Load Dump rating.
 - PJM will perform the following analysis for any facility that reaches or exceeds 115% of its Load Dump limit:
 - Study the loss of the contingency element and the overloaded facility

Post-Contingency Load Dump Limit Exceedance Analysis

Manual 13, Section 5.4.1

- PCLLRW is issued after:
 - All other means of transmission constraint control have been exhausted, or
 - Until sufficient generation is on-line to control the constraint within designated limits and timelines
- If post-contingency flow were to exceed the 15-minute Load Dump rating, the facility may trip before actions can be taken to reduce the flow within limits
- To prepare for this potential N-2 (initial contingency plus the overloaded facility) and prevent a cascade:
 - PJM will perform up to an N-5 on facilities over 115% of their 15-minute Load Dump rating

Cascade Analysis Simulation

Post-Contingency Load Dump Limit Exceedance Analysis

Manual 13, Section 5.4.1

- If the study results indicate that:
 - No additional facilities will be overloaded over 115% of their Load Dump limit:
 - This is a localized event, and no additional pre-contingency actions will be taken
 - Additional facility(s) over 115% of its Load Dump rating, the operator will continue the analysis to also trip the additional circuits:
 - Analysis will be performed, tripping a maximum of 5 facilities
 - Either a non-converged case, or continues to show facilities exceeding 115% of their Load Dump limits:
 - This will be considered a potential cascade situation

Post-Contingency Load Dump Limit Exceedance Analysis

PJM's EMS has a Cascade Analysis program which is set to...

- Run automatically whenever SA detects a post contingency violation which is equal to or greater than 115% of the load dump rating
- Results are shown on the SA Thermals display in TNA
- Provides more accurate results than manually performing cascade analysis because it removes multiple facilities from service in a single contingency

This will give different results than running Power Flow after each line is removed from service in study mode

Post-Contingency Load Dump Limit Exceedance Analysis

Manual 13 Section 5.4.1

- PJM operator will review the results with the Transmission Owner and direct pre-contingency Load Shed
- If the analysis at any point results in a valid non-converged contingency indicating a potential cascade
 - The PJM Operator will review the results with the Transmission Owner, and
 - Direct pre-contingency Load Shed within 30 minutes to mitigate the potential cascade situation

Note: Load Shed will be directed in the amount needed to maintain the post contingency flow below 115% of the Load Dump limit on the original contingency within 30-minutes of detection of the potential cascade situation

Manual Load Shed Determination Procedure

For a facility exceeding its LD, STE or LTE rating:

- Contact between PJM and TO should be made immediately
 - In particular for a facility exceeding its LD rating
- Compare real-time flows to state estimator flows

For any discrepancies:

- The reason is obvious and facility is not overloaded
 - PJM and TO should work together to resolve the discrepancy, log it and cease Load Shed Determination Procedure
- The reason is not immediately obvious
 - PJM and TO shall agree upon the most conservative values

Manual Load Shed Determination Procedure

- Compare LD and Emergency ratings

For any discrepancies:

- The reason is obvious and facility is not overloaded
 - PJM and TO should work together to resolve the discrepancy, log it and cease Load Shed Determination Procedure
- The reason is not immediately obvious
 - PJM and TO shall agree upon the most conservative values

Manual Load Shed Determination Procedure

- Switching and Generation option
 - For a LD rating overload, there are only 3 options available to alleviate:
 - A reclose attempt on the facility that tripped to cause the violation
 - Pre-studied switching solution
 - Generation re-dispatch (if generation can move fast enough)

Note: A Pre-Studied Switching Solution must be ...

- A switching that had been agreed upon by both the TO and PJM which:
 - Had been studied prior to the initiating event for present Load Dump overload
 - The study should have accurately reflected the initiating event and present system topology for the area presently experiencing the Load Dump overload
 - The switching solution CANNOT place any other facility into a Normal Rating overload

Manual Load Shed Determination Procedure

- For an Emergency (LTE or STE) overload:
 - May be time to study Switching Solutions and/or Generation Re-dispatch
 - Once overload is 5 minutes away from becoming a violation, and
 - If a switching solution and/or re-dispatch is not expected to relieve the overload in the next 5 minutes
- Commence **Load Shed Directive** immediately and without delay

Note: The amount of load shed required in a *Load Shed Area* is typically dependent upon the amount of load under SCADA control in the *Load Shed Area*. As such, the TO may have to shed a substantial amount of load that significantly reduces the flow across the *Overloaded Facility* (sometimes well below the NL rating on said facility) due to limited SCADA control.

However, this is the desired effect, to protect the *Overloaded Facility*. If significant load shed is required, the TO should shed the load first to protect the facility... then, in coordination with PJM, fine-tune the load shed afterwards with the help of additional TO personnel (substation, switchman, etc.)

Manual Load Shed Determination Procedure

- The following is meant to be a template script for issuance of a Load Shed Directive
- The Script should be readily available to both PJM and TO operators as a reference
- The intent of the script is for familiarity and easy recognition of the gravity of the situation
- Both operators should take special note that the tone of the Directive is meant to be formal, clear and specific
- At the beginning, during and at the completion of the Directive, there should be no ambiguity as to what is taking place or what needs to be done to alleviate the situation
 - As such, no extraneous conversation outside of the directive should take place either during the Directive or at the end of the Directive
- **If at any time during the issuance of the Directive, either party becomes distracted for any reason, they should cancel the order and commence from the beginning**

Example Script

Keywords:

- ***PJM Operator:*** John Doe
- ***TO Company:*** XYZ Energy
- ***TO Operator:*** A.J. Jones
- ***Present Time:*** 1208
- ***Overloaded Facility:*** Victorstation 345/138kV #2 Transformer
(which is presently overloaded with flow from the 345kV high side down to the 138kV low side)
- ***Facility Flow:*** 705 MVA
- ***Rating:*** LD rating. (650 MVA)
- ***Overload Time:*** 1206
- ***Desired Flow:*** 590 MVA LTE/STE rating
- ***Load Shed Area:*** Victorstation 138kV and below

Script Verbiage

PJM Operator:

- “This is PJM Dispatcher John Doe with a Load Shed Directive.”
- “As of 1208, the Victorstation 345/138kV #2 Transformer is determined to be exceeding its Load Dump rating of 650 MVA and is presently loaded at 705 MVA.
The facility has been exceeding its Load Dump rating since 1206.”

TO Operator:

- “I agree that as of 1208, the Victorstation 345/138kV #2 Transformer is determined to be exceeding its Load Dump rating of 650 MVA and is presently loaded at 705 MVA. I also agree that the facility has been exceeding its Load Dump rating since 1206.”

PJM Operator:

- "That is correct."

Script Verbiage

PJM Operator:

- “At this time PJM is initiating a Load Shed Directive to reduce the flow across the Victorstation 345/138kV #2 Transformer to a level not to exceed 590 MVA. XYZ Energy should commence load shed in the Victorstation 138kV and below area immediately.”

TO Operator:

- “I agree that a Load Shed Directive has been ordered to immediately commence load shed in the Victorstation 138kV and below area with the intent to reduce the flow across the Victorstation 345/138kV #2 Transformer down to a flow that does not exceed 590 MVA.”

PJM Operator:

- “That is correct. Please call me back to confirm once the load shed is completed.”

Post Contingency Congestion Management Program

Post-Contingency Congestion Management Program

- Background
 - PJM analysis indicates that probability of contingent facility tripping during an off-cost event is less than .05%
 - It's prudent to operate to a higher pre-contingency threshold (i.e. 30 minute rating)
 - If ample quick-start generation or switching actions are available, eliminate an actual overload should a contingent facility tripping occur
 - Generation must demonstrate a history of adequate availability and response

Post-Contingency Congestion Management Program

- Criteria

- Outage of contingent facility must not cause a cascading outage or precipitate an uncontrolled separation within and/or external to the PJM RTO
- EHV facilities not included in the program
- Transmission owner of the facility will have an established short-term emergency rating (normally 30 minutes)
- Facilities must have more than one quick-start CT or diesel in the vicinity, and off-line, to eliminate the contingency should it occur

Post-Contingency Congestion Management Program

- Criteria: Quick-start CT or diesel must meet the following criteria:
 - An availability of 120% of necessary generation to obtain the required MW relief from 30 minute rating to normal rating must be demonstrated (Account for the possibility of some generation not starting)
 - Net generation must have history of being on-line and loaded within 30 minutes 85% of the time
 - Where available, condensers will be brought on-line for control once a contingency flow reaches the 4-hour emergency rating
 - This program will be implemented during non-winter months for facilities where fast-start generation is used for control
 - Switching procedures that demonstrate successful winter implementation may be included under the program year-round

Post-Contingency Congestion Management Program

- Alternative Controlling Options
 - TO may offer generation run-back schemes to control for these facilities
 - Subject to ramp rate testing data as supplied by the Generation Owner
 - TO may utilize switching and reclosing procedures to control for these facilities
 - Procedures must be studied and approved by PJM
 - Post-contingency switching must be implemented via SCADA control
 - TO must have ability to dump sufficient load via SCADA if switching procedure can not be implemented
 - Switching procedures may be implemented pre-contingency once contingency flow exceeds the 30-minute rating and all generation has been called

Post-Contingency Congestion Management Program

- Systems designed for post-contingency switching:
 - On a pre-contingency basis, off-cost operations will commence once simulated contingency flow, using *Guide Implemented* contingency definitions, reaches the Long-term emergency rating
 - On a pre-contingency basis, off-cost operations will commence once simulated contingency flow, using the *Guide Failed* contingency definitions, approaches the Load Dump Rating
 - In the event of a contingent facility tripping, the appropriate guide scheme will be used to ensure flow drops below the Long-term emergency rating.
 - Generation redispatch, if needed, will be used to bring the flow below the normal rating

Post-Contingency Congestion Management Program

- **PJM Roles/Responsibilities**

- Selection/analysis/approval for facilities in program
- Communicate and consult with the Transmission Owner to ensure that the analysis is accurate
- Publish facilities in Manual M-03, Transmission Operations
- Operate facility to Short-term rating provided by Transmission Owner
 - If the rating is exceeded pre-contingency, off-cost operations will be used to mitigate the simulated overload

Post-Contingency Congestion Management Program

- **Transmission Owner Roles/Responsibilities**
 - Review and comment on the proposed facilities
 - For any disagreements concerning proposed facilities:
 - PJM has a Dispute Resolution Process in place
 - PJM will delay implementation of the facility until the disagreement is resolved
 - May offer additional facilities to be studied for inclusion into the program

Post-Contingency Congestion Management Program

- **Generation Owner Roles/Responsibilities**

- Operate fast-response generation in accordance with PJM's current rules and procedures
- When called upon to mitigate a transmission outage on a facility included in the program, the generation owner shall start the unit in accordance with PJM's instructions

Post-Contingency Congestion Management Program

- The list of facilities is in Transmission Operations Manual 3, Attachment D



Transmission Loading Relief (TLR)

Transmission Loading Relief Procedure (TLR)

- NERC TLR
 - Transmission Loading Relief is a NERC procedure that is used to safely and effectively reduce flow on a transmission element on the bulk power system
 - Used in the Eastern Interconnection
 - Respects transmission service reservation priorities
 - Mitigates potential or actual Operational Security Limit violations

Transmission Loading Relief Procedure (TLR)

- PJM TLR Definition:
 - The PJM procedure includes the NERC procedure but incorporates generation re-dispatch prior to implementing the Transmission Loading Relief Procedure as a means for managing congestion

Transmission Loading Relief Procedure (TLR)

- PJM TLR Procedure

- Step 1 - Implement non-cost measures to control power flow
- Step 2 - Curtail transactions in PJM that are “not willing to pay through congestion”
- Step 3 - Adjust output of generators off-cost to alleviate overloads
- Step 4 - Implement the NERC TLR procedure
- Step 5 - Curtail external customers or charge external customers for congestion
- Step 6 - Curtail remaining transactions in priority order

Transmission Loading Relief Procedure (TLR)

NERC TLR Procedure Levels

- TLR Levels 1 - Notification
- TLR Level 2 - Hold Interchange Transactions
- TLR Level 3a - Reallocation Non-firm Point-to-Point
- TLR Level 3b - Curtailment Non-firm Point-to-Point
- TLR Level 4 - Reconfiguration
- TLR Level 5a - Reallocation Firm Point-to-Point
- TLR Level 5 b - Curtailment Firm
- TLR Level 6 - Emergency Procedure
- TLR Level 0 - TLR Concluded



Transmission Loading Relief Procedure (TLR)

Transmission Service Priorities

Priority 0 NX - Next -hour Market Service

Priority 1 NS - Service over secondary receipt and delivery points

Priority 2 NH - Hourly Service

Priority 3 ND - Daily Service

Priority 4 NW - Weekly Service

Priority 5 NM - Monthly Service

Priority 6 NN - Network Integration Transmission Service from sources not designated as network resources

Priority 7 F - Firm point-to-point Trans Service and Network Integration Transmission Service from designated resources

Transmission Loading Relief Procedure (TLR)

- Other concepts you need to know:
 - Power Flow Model
 - Flowgates
 - Transfer Distribution Factors
 - NERC E-Tags
 - Transmission Service Priorities
 - IDC (Interchange Distribution Calculator)



Transmission Loading Relief Procedure (TLR)

- **Power Flow Model**

- Models the actual configuration of the Eastern Interconnection
- Contains Generator & Transmission status
- Created once every hour
- Can be updated three times an hour
- Reliability Coordinators are responsible for updating the model

Transmission Loading Relief Procedure (TLR)

- **Flowgates**

- A flowgate is a boundary between two parts of a transmission system across which there **may** be congestion
- Flowgates may cut across a number of circuits and because they “cut” across circuits, they are known as CUT SETS
- The key characteristic of a flowgate is that it has a well defined limit of power that can flow across it
- A flowgate may have thermal, voltage, phase angle and/or stability limitations

Transmission Loading Relief Procedure (TLR)

- **Transfer Distribution Factors**

- Transfer Distribution Factors represent the impact of an interchange transaction between one control area to another control area on a given flowgate
- There are two types of Transfer Distribution Factors (TDF) calculated
 - Power Transfer Distribution Factors (PTDF) - These factors are calculated to consider the effect of a transaction on a flowgate
 - Outage Transfer Distribution Factor (OTDF) - These factors are calculated to consider the effect of a transaction on a flowgate after an outage of another facility

Transmission Loading Relief Procedure (TLR)

NERC E-Tags

- Provide a tag name to determine the Source and Sink Control Areas
 - Provides OASIS information to determine priority
 - Provides the energy profile to determine MW flow
 - Each E-TAG will have Transfer Distribution Factor assigned by the IDC per individual flowgate
 - Only Interchange Transactions with a TDF of 5% or greater are subject to TLR Curtailments

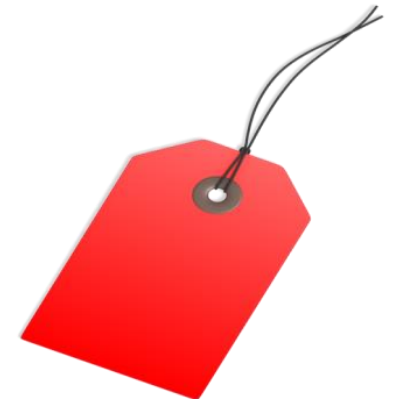

Transmission Loading Relief Procedure (TLR)

- **Interchange Distribution Calculator (IDC)**

- Primary tool used for NERC TLR
- Calculates Transfer Distribution Factors (TDF) for specific flowgates
- Uses an updated power flow model of the Eastern Interconnection
- Obtains interchange transaction data from NERC E-Tags
- Provides TLR Level notification
- Creates Curtailment report for specific flowgates



Constraint Management Mitigation Procedure

Constraint Management Mitigation Procedure

- Purpose

- Allows for BRIEF deviations from thermal operating criteria to accommodate switching
 - Results in maintaining system integrity by keeping lines/facilities in service during these short term excursions
 - Reduces the occurrence of unnecessary off-cost operation
 - Normal Limits can be exceeded briefly without damaging equipment due to the lengthy thermal time constants for heat build-up in equipment
 - Supported by Equipment Engineers

Constraint Management Mitigation Procedure

- Requirements
 - Pre-agreement by PJM OPD, PJM Dispatch and TO Dispatch (and anyone else who is involved)
 - If the above parties are not in agreement on the use of this procedure, the procedure should not be utilized
 - Planned event **MUST** be pre-studied on a case by case basis
 - Each operation or use of this procedure should be documented and logged

Constraint Management Mitigation Procedure

- Requirements *(con't)*
 - PJM will **NOT** allow actual operation over the Emergency thermal rating on an actual basis for ANY period of time
 - Operation over the normal rating will be tolerated for up to 5 minutes (with an approved “back-out” plan)
 - PJM will **NOT** allow operation over the Load Dump rating on a post-contingency basis for ANY period of time
 - Operation over the Emergency Rating on a post-contingency basis will be tolerated for up to 5 minutes (with an approved “back-out” plan)

Constraint Management Mitigation Procedure

- Requirements *(con't)*
 - Planned event (overload) should take no longer than 5 minutes
 - “Back-out” plan must be in place to alleviate the overload should event be extended due to unexpected circumstances



Constraint Management Mitigation Procedure

- Back-out Plan
 - Must be agreed to by all parties
 - Must not impact other members
 - Must return overloaded facility within limits in **15 minutes or less** from the start of the outage
 - Must have sufficient redundancy
 - SCADA and physical control
 - Variety of options
 - Multiple CTs
 - Must be pre-studied and studied for actual system conditions

Constraint Management Mitigation Procedure

- General
 - Communication and Coordination are the keys to success of this procedure
 - PJM ↔ TO, TO ↔ Field
 - All personnel must be in place and ready to implement “Back-out” plan if it becomes necessary
 - No safety or standard switching procedures should be violated in implementing the back out plan
 - ALL requirements of this procedure must be met to allow for the application of this procedure
 - This procedure is an option available to the TO and may not be applicable for all situations

Constraint Management Mitigation Procedure

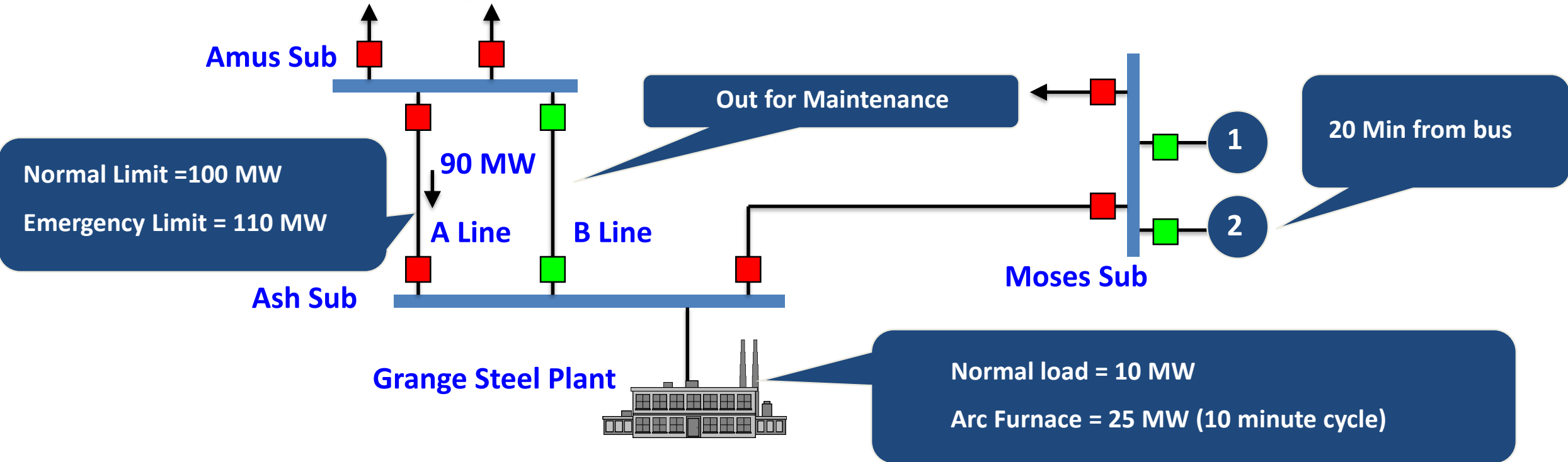

PAL Power wants to take out line Amus – Ash B Line for maintenance. If the Grange Steel Plant arc furnace is on, the load on the A Line increases to 115 MW. PAL Power says that these furnaces generally only run for a 10 minute cycle, then the loading will return to under the 100 MW limit. They have a “back-out” plan in case the arc furnace stays on longer than expected, running the Moses CTs will reduce the A Line flow under the 100 MW limit

Is this a candidate for the Constraint Management Mitigation Procedure?

Constraint Management Mitigation Procedure

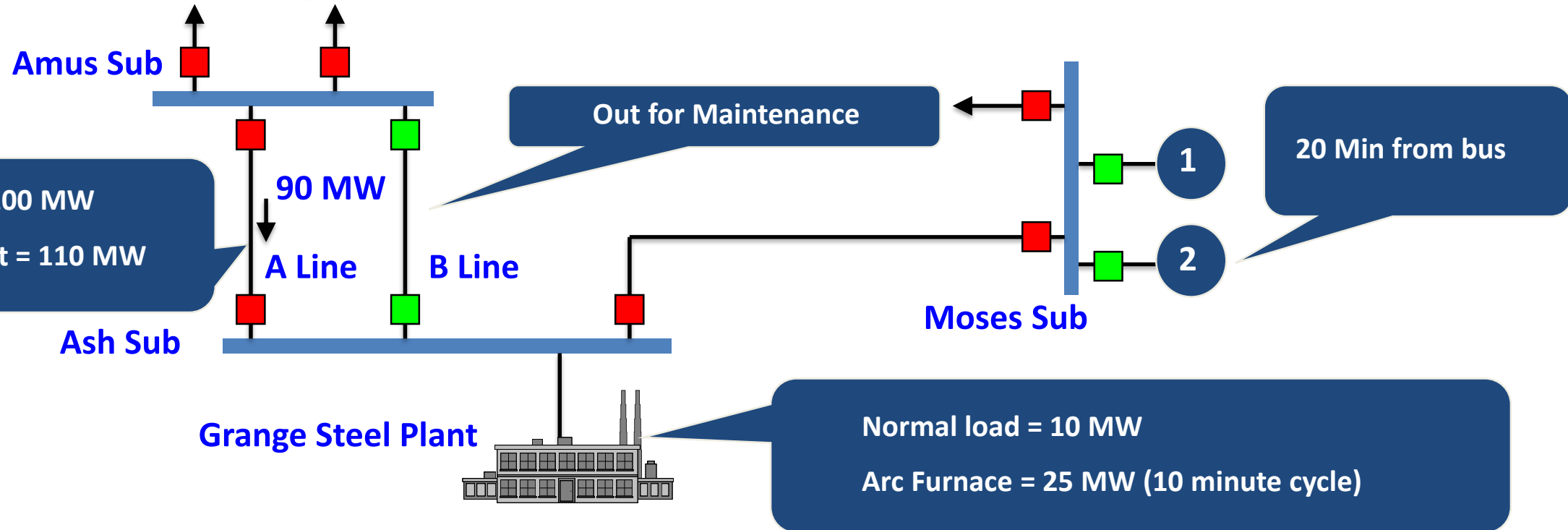

- This action is NOT a candidate for the Constraint Management Mitigation Procedure for the following reasons:
 - The Emergency limit on A Line can not be exceeded for any length of time
 - In this example the Emergency limit would be exceeded for at least 10 minutes
- The Moses CTs are 20 minutes from the bus
 - The “back-out” plan must alleviate the overload within 15 minutes

Constraint Management Mitigation Procedure

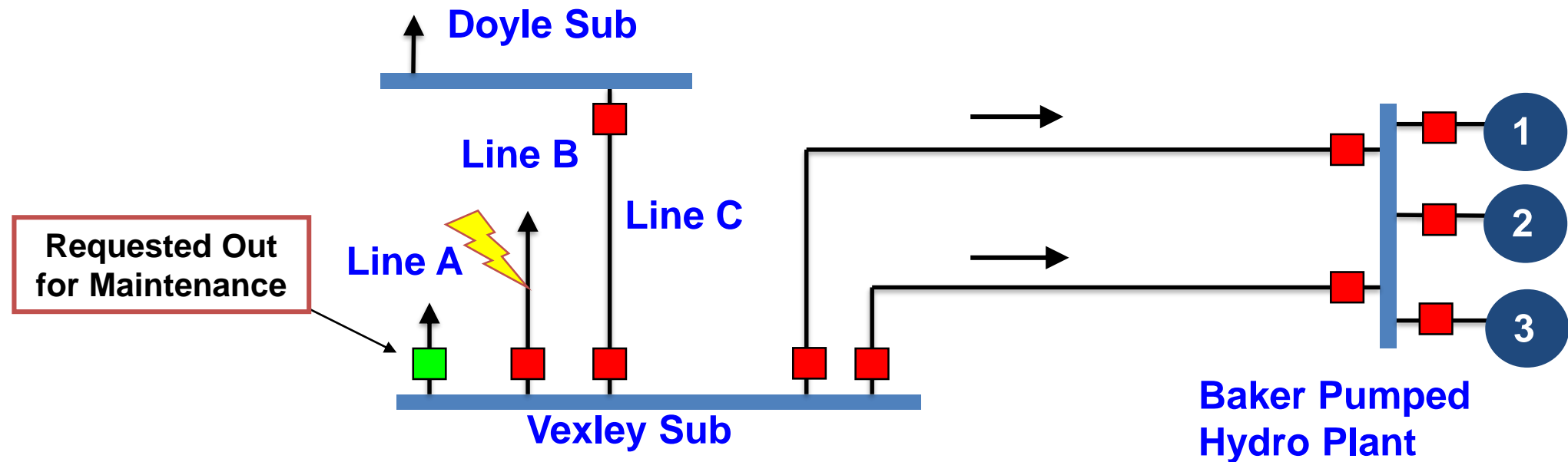

PAL Power wants to take out Line A for 1 week for maintenance. If all 3 pumps are on at the Baker Pumped Hydro Plant, a contingency exists on Line C for the loss of Line B (with Line A out of service). This contingency is over the emergency rating on Line C (on a contingency basis) but under the Load Dump Rating. PAL Power has a “back-out” plan of dumping one of the three pumps at Baker Pumped Hydro Plant (which they own) to bring the loading on Line C back under the normal rating in within 10 minutes

Is this a candidate for the Constraint Management Mitigation Procedure?

Constraint Management Mitigation Procedure

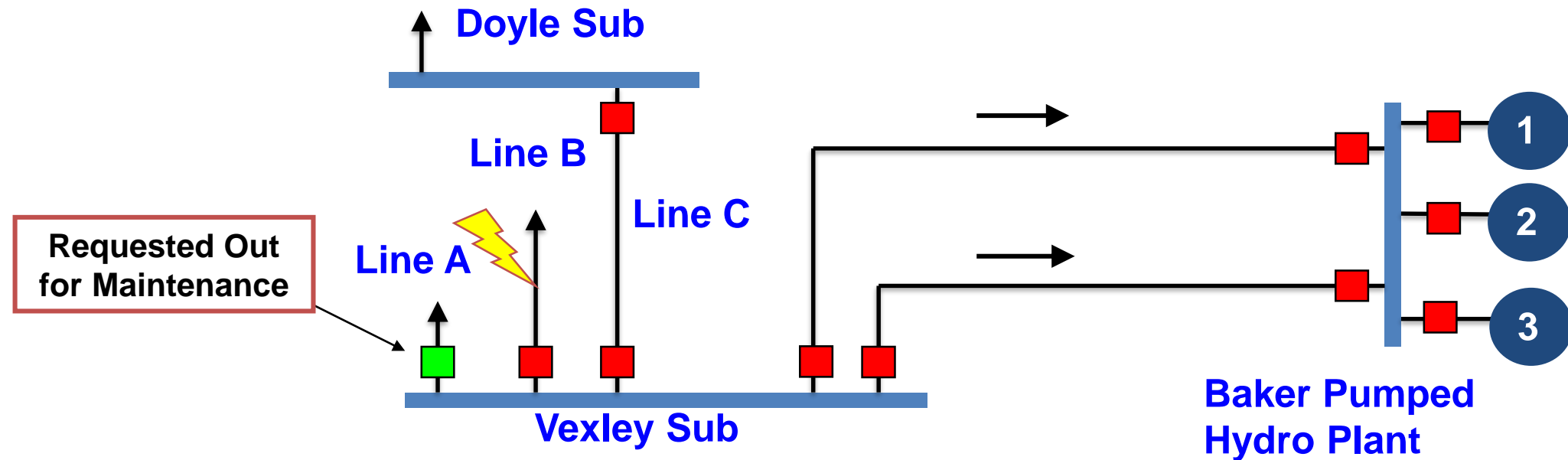

- This action is NOT a candidate for the Constraint Management Mitigation Procedure for the following reason:
 - The Contingency on Line C will exist for more than 5 minutes
- The Constraint Management Mitigation Procedure allows for operation over the applicable Emergency Rating on a post contingency basis for up to 5 minutes only

Constraint Management Mitigation Procedure

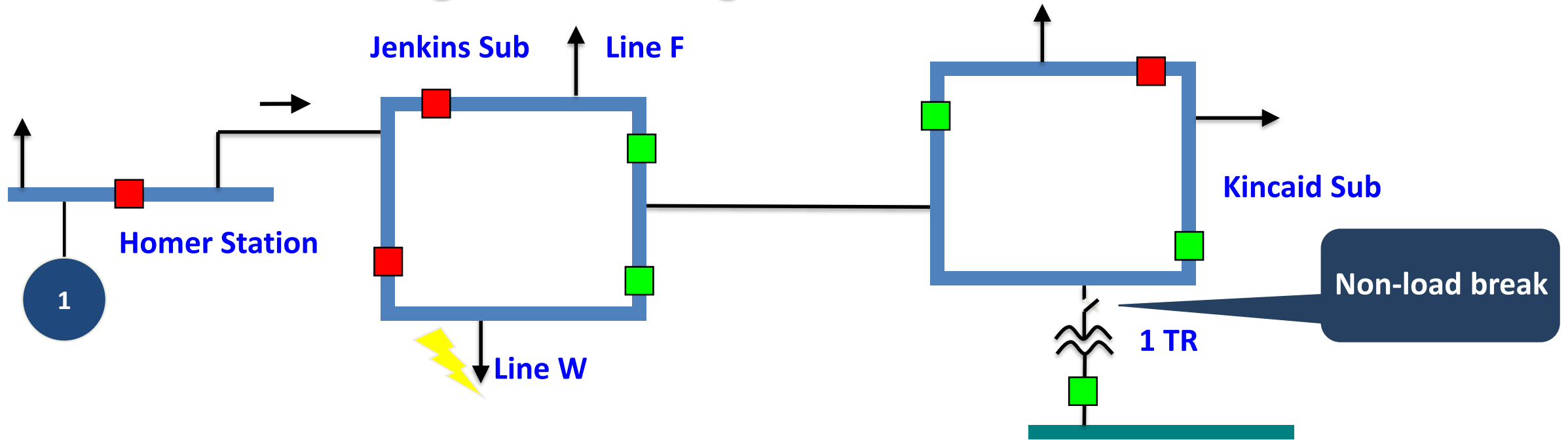

PAL Power wants to take out the 1 TR at Kincaid Sub for maintenance. The high side disconnect of the transformer is non-load break and must be operated de-energized. This will entail switching out the Jenkins – Kincaid line to open the disconnect. The Jenkins – Kincaid line can then be switched back into service. However, while the Jenkins – Kincaid line is off, studies indicate Line F will be over emergency rating (under Load Dump) for the loss of Line W. The back-out plan is to open the bus tie CB at Homer Station to alleviate the contingency if necessary. This plan has been studied and will alleviate the contingency immediately upon opening the tie CB. Personnel are in place at all three substations for the switching and it is anticipated that the disconnect can be opened in less than 5 minutes. All those affected by this plan have been notified and are in agreement with the plan

Is this a candidate for the Constraint Management Mitigation Procedure?

Constraint Management Mitigation Procedure

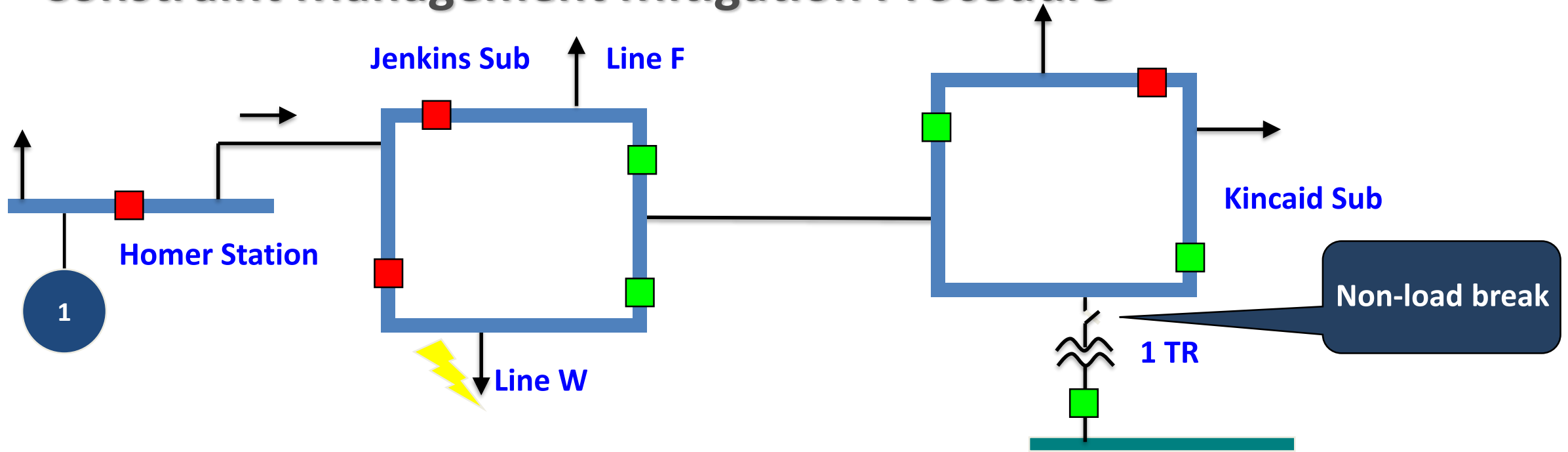

- This action IS a candidate for the Constraint Management Mitigation Procedure for the following reasons:
 - The contingency on Line F for the loss of Line W is only expected to last for less than 5 minutes
 - The contingency on Line F is over the Emergency Rating but UNDER the Load Dump Rating
- The Back-out plan will relieve the contingency in a total time of under 15 minutes. The back-out plan was approved by all parties and studied thoroughly

Voltage Limits

- Definition
 - A high and/or low limit placed on voltage to avoid damage to equipment and maintain power system voltage levels at a reliable level
- Affected equipment
 - Motors
 - Transformers
 - Generators
 - Loads
 - Capacitors

Voltage Limits

- Determination of Voltage Limits
 - Maintain system reliability
 - High voltage limits are equipment related
 - Low voltage limit are system related
 - Established by equipment manufacturers
 - ANSI Standards provide basis for voltage schedules
 - 97.5% - 105.0% Normal
 - 95.0% - 105.8% Emergency
 - These limits are for customer voltage

Voltage Limits

- Consequences of deviations from voltage limits
 - Low voltage
 - Dim lights
 - Slow heating of heating devices
 - Difficulty starting motors
 - Overheating/damage to motors
 - High voltage
 - Light bulb life decreased
 - Electronic devices life decreased



Voltage Limits

Limit	765 kV	500 kV	345 kV	230 kV	161 kV	138 kV	115 kV	69 kV
Normal High	803.3	550	362.3	241.5	169.1	144.9	120.8	72.5
Normal Low	726.8	500	327.8	218.5	153	131.1	109.3	65.6
Emerg Low	703.8	485	317.4	211.6	148.1	127	105.8	63.5
Load Dump	688.5	475	310.5	207.0	144.9	124.2	103.5	62.1
V-drop Warning	5%	2.5%	5%	5%	5%	5%	5%	5%
V-drop Limit	8%	5%	8%	8%	10%	10%	10%	10%

Voltage Limits

- Transmission Owners may specify bus-specific voltage limits
 - Submit limit in writing to PJM, Manager Operations Planning
 - PJM will evaluate these limits for reasonableness
 - PJM will return confirmation of new limits to SOS representative when limits are in EMS
 - PJM will forward new limits to System Planning for use in future planning studies
 - Provided engineering justification exists, PJM allows member company to set more restrictive voltage limits
- Manual M-03, Attachment C for details*

Causes of Low Voltage

- Due to excessive VAR loading
 - Usually seen as voltage drop in an area rather than a single bus
- Due to voltage regulation malfunction
 - Generator voltage regulator may fail
 - Transformer tap changer hang-up
 - Usually seen as voltage decrease at a single bus
 - May result in an imbalance in MVAR flows or circulating MVAR
- Due to Geo-Magnetic Disturbance
 - Increased VAR requirement in system
 - Var absorption by EHV transformers

Causes of High Voltage

- Due to light load
 - Caused by excess line capacitance
 - Voltage rise in area rather than a single bus
- Due to switching in a line with high capacitive charging current
 - Reactive supplied by charging of line
- Also caused by:
 - Voltage regulation malfunction
 - Excess VAR sources on system

Detection of Voltage Problems

- Observe Critical Bus Voltages
 - Where do problems appear first?
- Observe Voltages in an Area
 - Determine if deviation is on a single bus or over an area on the system
- Observe Voltage Alarms
- Monitoring Sources
 - EMS, map board, trends, field reports, customer complaints
 - Monitor voltages, limits, alarms, and MVAR flow



VAR Sources and Sinks

- Voltage Control Means MVAR Control
 - Control of voltage and reactive power are inseparable!
 - MVAR sources support or hold up voltages
 - Capacitors
 - Generators / Synchronous Condensers
 - Static VAR Compensators
 - System Capacitance
 - MVAR sinks pull down voltages
 - Reactors
 - Generators / Synchronous Condensers
 - Loads
 - System Inductance/Mvar Losses
 - Static VAR Compensators



System Voltage Characteristics

- Results - a constantly changing voltage profile

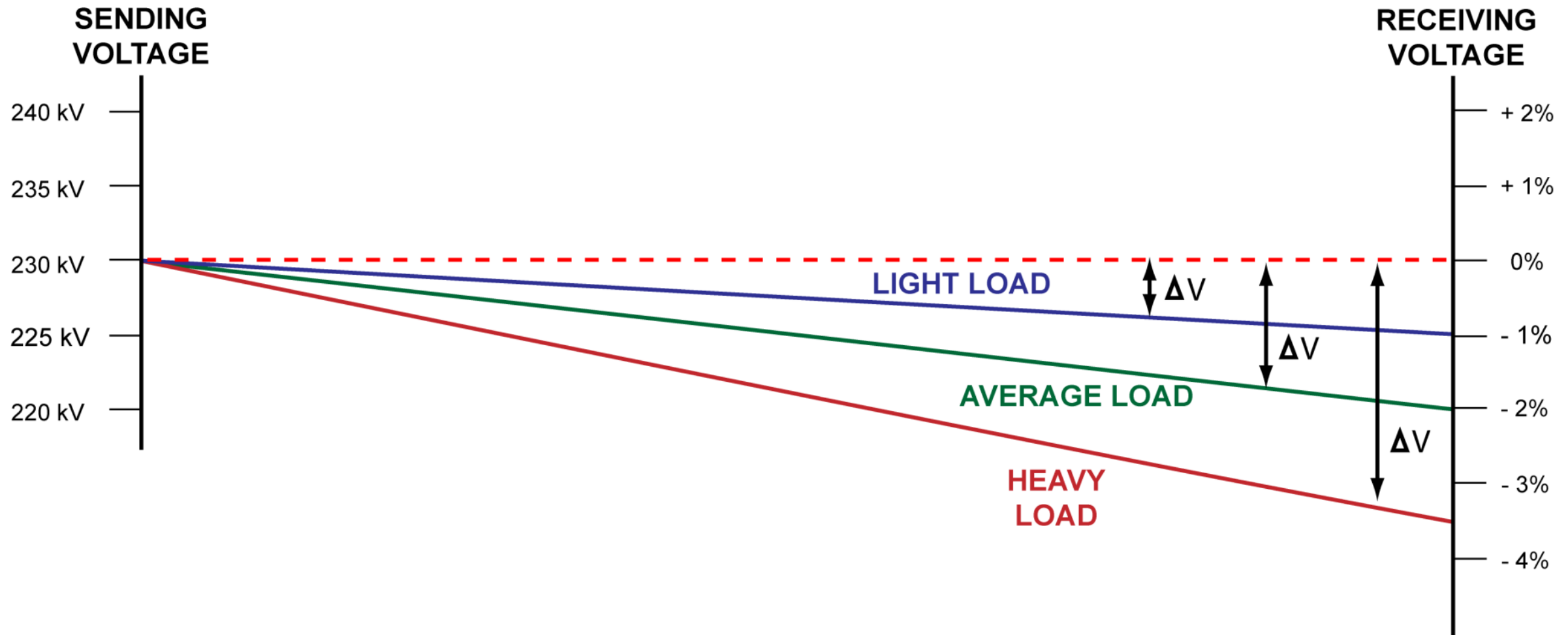

System Voltage Characteristics

- Results - for light loads, voltage can rise due to low losses and line capacitance

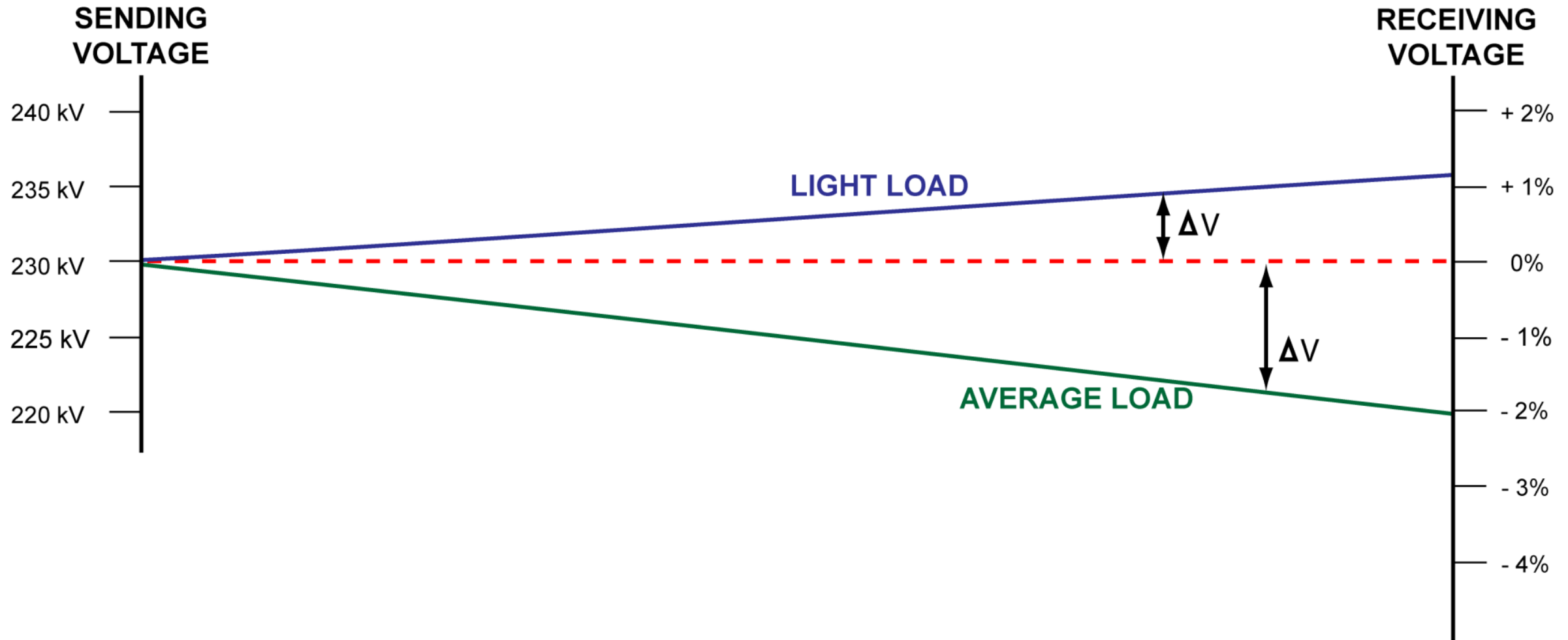

VARs From Transmission Lines

- The Ferranti effect is an increase in voltage occurring at the receiving end of a long transmission line, above the voltage at the sending end when the line is energized, but there is a very light load or the load is disconnected
- Dependent on:
 - Source voltage
 - Line Length

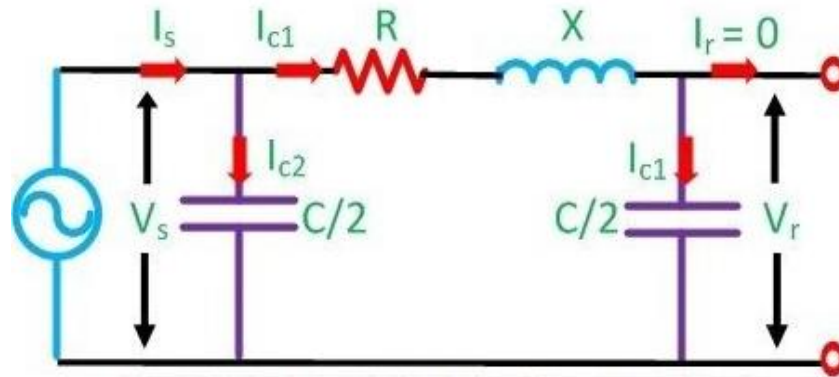

VARs From Transmission Lines

- Line open at one end

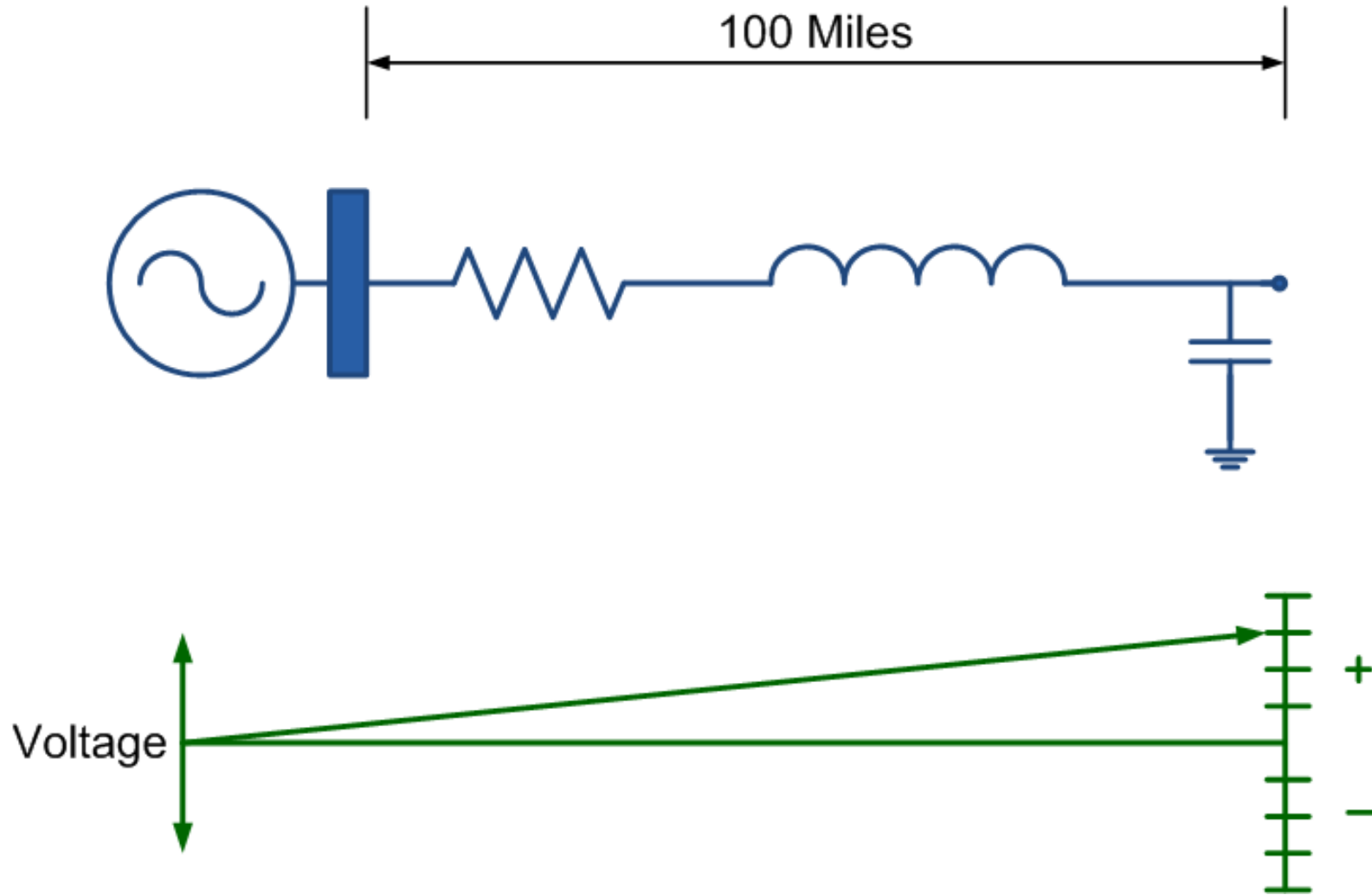

VARs From Transmission Lines

- Switching Operations
 - Open one end
 - Provides VARs to closed end of line due to line capacitance

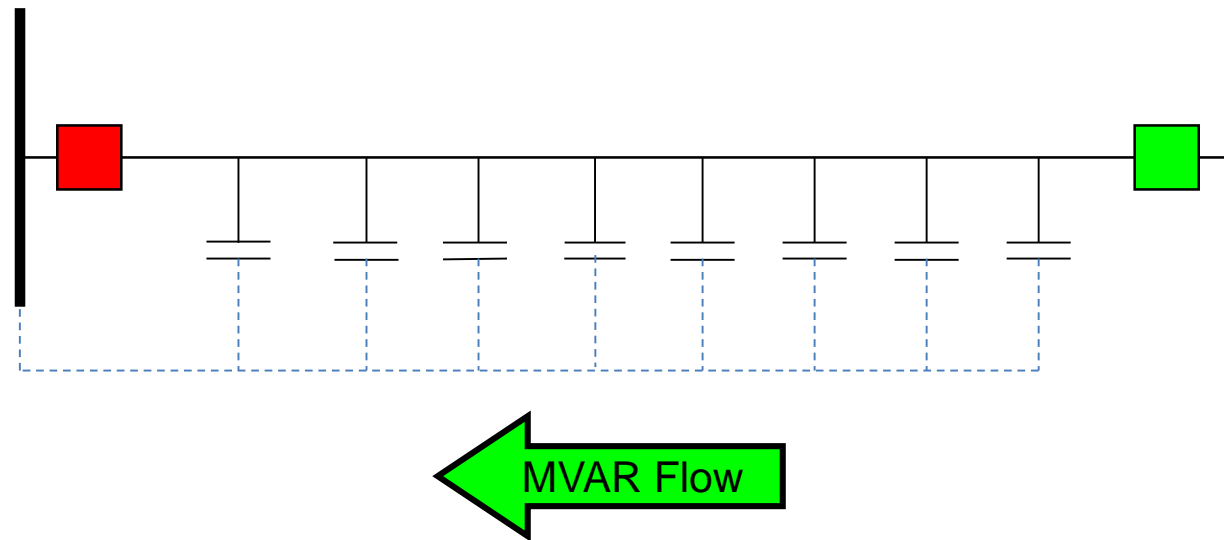

VARs From Transmission Lines

- VARs supplied by charging of line

MVARs Supplied by Lines and Cables		
Voltage	Transmission Line	Transmission Cable
765 kV	4.6 MVAR/Mile	
500 kV	1.7 MVAR/Mile	
345 kV	0.8 MVAR/Mile	15–30 MVAR/Mile
230 kV	0.3 MVAR/Mile	5-15 MVAR/Mile
115 kV	0.1 MVAR/Mile	2-7 MVAR/Mile

VARs From Transmission Lines

- Line connected to load
 - Real Power (MW) losses increase with load
 - Reactive Power (MVAR) losses increase with load

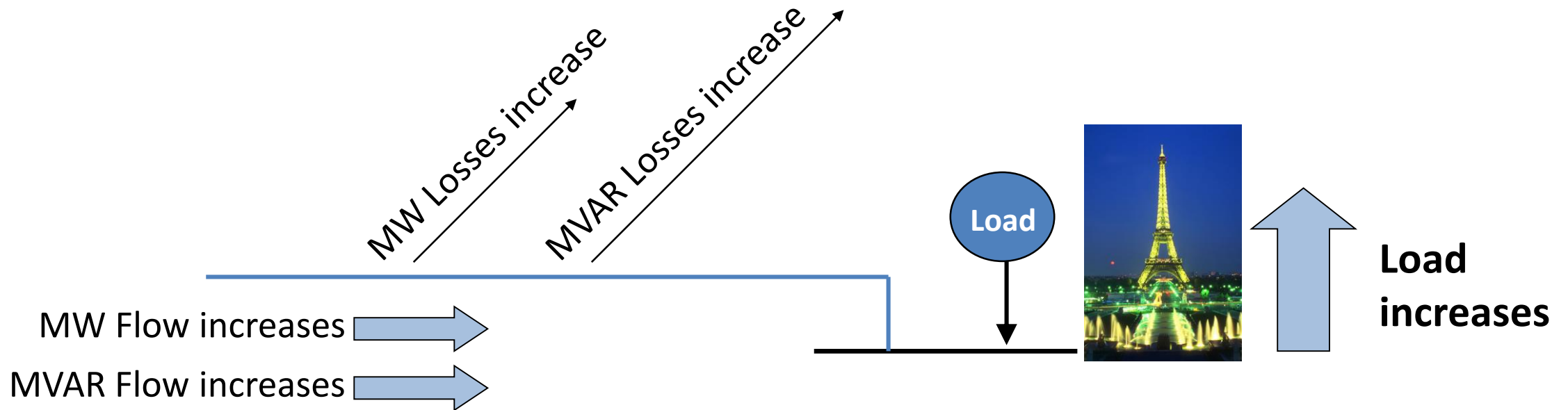

VARs From Transmission Lines

- Surge Impedance Loading

- Loading point where VAR losses on a line equal VARs generated by line

- 765 kV = 2100 MW

- 500 kV = 850 MW

- 345 kV = 400 MW

- 230 kV = 135 MW

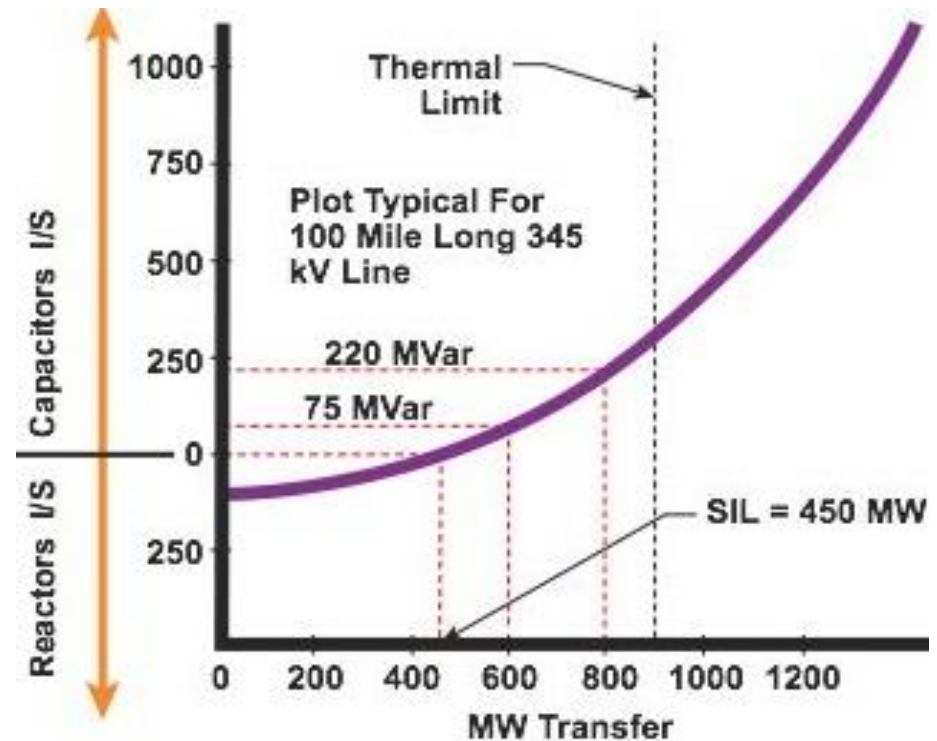

VARs From Transmission Lines

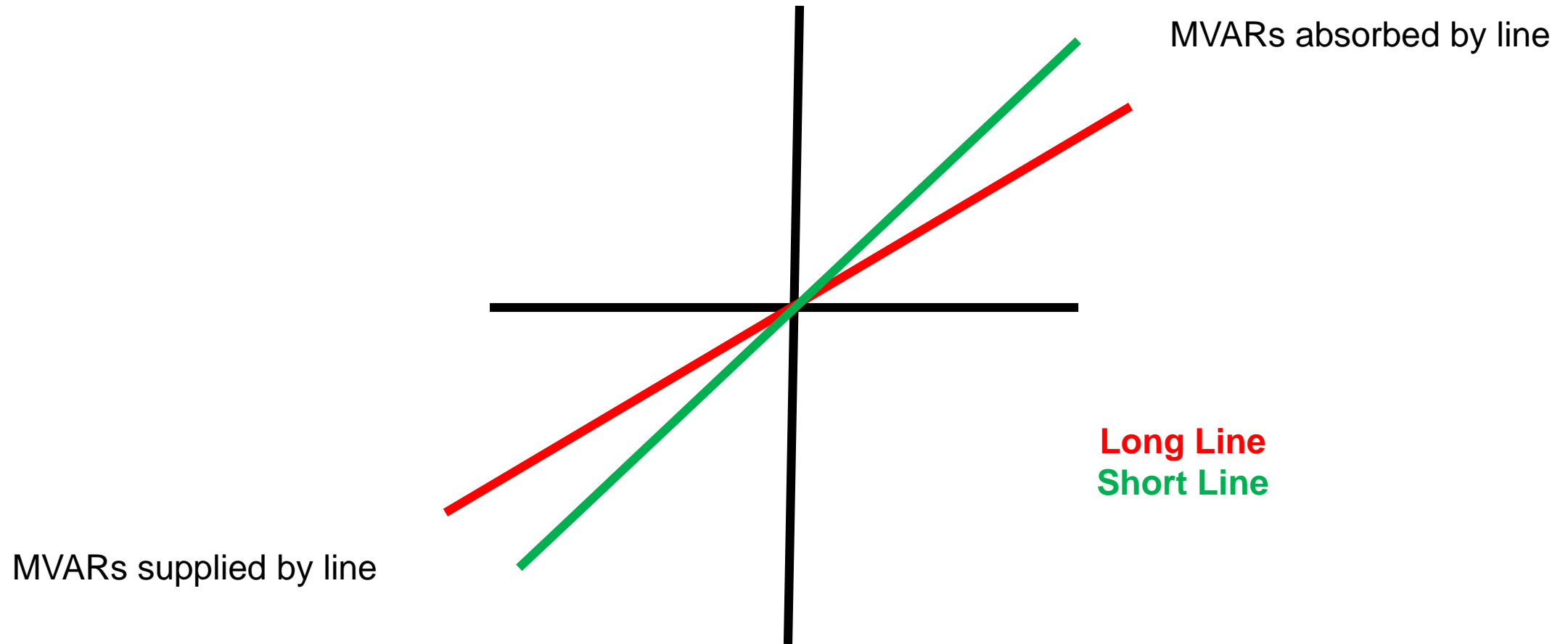

Surge Impedance Loading Example

VARs From Transmission Lines

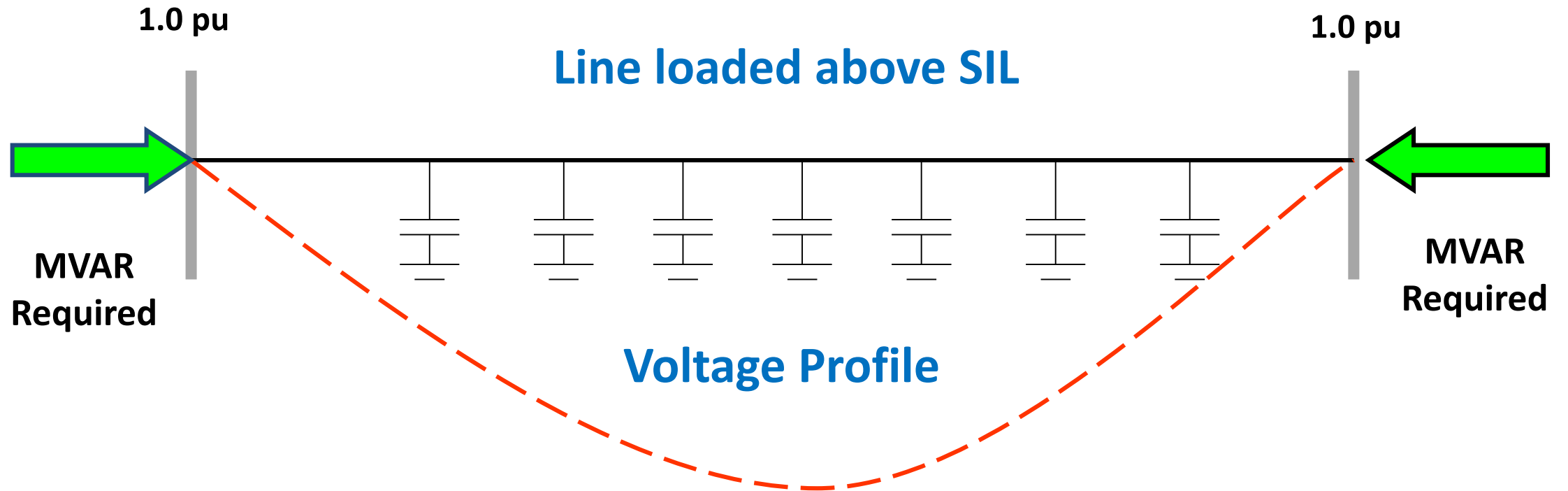

As line loading increases:

Reactive losses increase proportional to I^2

Reactive supply decreases proportional to V^2

VARs From Transmission Lines

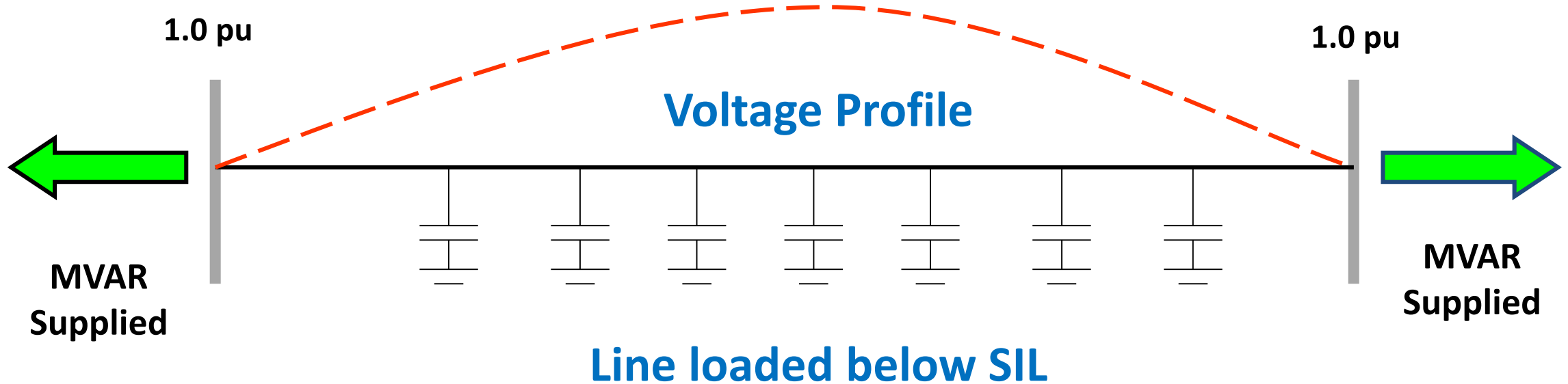

As line loading decreases:

Reactive losses decrease proportional to I^2

Reactive supply increases proportional to V^2

Voltage Operating Criteria

- PJM will operate so that no monitored facility will violate:
 - Normal voltage limits on an actual or continuous basis
 - Emergency voltage limits following any simulated facility malfunction or failure
 - If a limit is violated, system readjustment should take place within 30 minutes but a 60-minute maximum time is allowed prior to issuing a Post-Contingency Local Load Relief Warning (PCLLRW)

Voltage Operating Criteria

Voltage Limit Exceeded	If Actual Voltage Limits Are Violated	Time to Correct (Minutes)
High Voltage	Use all effective non-cost and off-cost actions	Within 15 minutes
Normal Low	Use all effective non-cost actions, off-cost actions and emergency procedures except load dump	Within 15 minutes, load shed is not used
Emergency Low	All of the above plus, shed load if voltages are decaying	Within 5 minutes
Load Dump Low	All of the above plus, shed load if analysis indicates the potential for a voltage collapse	Immediate
Pre-Contingency Transfer Limit Warning Point (95%)	Use all effective non-cost actions. Prepare for off-cost actions. Prepare for emergency procedures except Load Shed Directive	Not applicable
Pre-Contingency Transfer Limit	All of the above including Load Shed Directive if analysis indicates potential for voltage collapse	Within 15 minutes or less depending on the severity

Voltage Operating Criteria

Voltage Limit Exceeded	If Post Contingency Simulated Voltage Limits Are Violated	Time to Correct (Minutes)
High Voltage	Use all effective non-cost actions	Within 30 minutes
Normal Low	Use all effective non-cost actions	Not applicable
Emergency	Use all effective non-cost actions, off-cost actions, and emergency procedures except load dump	Within 15 minutes, load shed is not used
Load Dump Low	All of the above plus, shed load if analysis indicates the potential for a voltage collapse	Within 5 minutes
Voltage Drop Warning	Use all effective non-cost actions	Not applicable
Voltage Drop Violation	All effective non-cost and off-cost actions plus, shed load if analysis indicates the potential for a voltage collapse	Within 15 minutes
Post-Contingency Transfer Limit Warning Point (95%)	Use all effective non-cost actions. Prepare for off-cost actions. Prepare for emergency procedures except Load Shed Directive	Not Applicable
Post-Contingency Transfer Limit	All of the above including Load Shed Directive if analysis indicates potential for voltage collapse	Within 15 minutes or less depending on the severity

Controlling Voltage Violations

Non-Cost Responses to Voltage Violations

- Capacitors
- Reactors
- Variable reactor tap position
- Static Var Compensators setpoint
- Generator excitation
- Transformer tap position
- Phase Angle Regulator tap position
- Switch lines or cables out of service

Controlling Voltage Violations

Off-cost Responses to Voltage Violations

- Curtail Non-firm transactions NOT willing to pay congestion (prior to generation re-dispatch)
- Re-dispatch generation
- Dispatch synchronous condensers
- Initiate ALL Emergency Procedures EXCEPT Load Shed
 - Including Manual Load Dump Warning

Controlling Voltage Violations

Load Shedding Response to Voltage Violations

- Determine if load shedding is required
 - All other control actions have been exhausted
 - Under emergency low or load dump low voltage limit on an actual basis or Reactive Transfer Limit to avoid voltage collapse
 - Under load dump low voltage limit or voltage drop violation limit on contingency basis if analysis indicates potential for voltage collapse
- Determine amount of load shed necessary
- Shed load proportional among Native Load customers, Network customers and firm point-point service

Corrective Actions

Condition: **Actual Voltage** exceeds High Voltage limit

- Time to correct: 15 minutes
 - Corrective Actions include:
 - Capacitor/Reactor switching
 - Tap changer adjustment
 - Generator/synchronous condenser excitation adjustment
 - Switching lines/cables out of service*
(*Facilities 500 kV & Above)
 - Off-cost generation adjustments

362 kV
High Voltage Limit

328 kV
Normal Low Limit

317 kV
Emergency Low
Limit

310 kV
Load Dump
Limit

Example 345 kV Facility



Corrective Actions

Condition: **Actual Voltage** is less than Normal Voltage limit but greater than Emergency Low Voltage limit

- Time to correct: 15 minutes
- Corrective Actions include:
 - Non-cost actions
 - Capacitor switching
 - Generator excitation adjustment
 - Tap changer adjustment
 - Off-cost generation adjustment
 - All emergency procedures EXCEPT load dump

362 kV
High Voltage Limit

328 kV
Normal Low Limit

317 kV
Emergency Low
Limit

310 kV
Load Dump
Limit

Example 345 kV Facility



Corrective Actions

Condition: **Actual Voltage** is less than Emergency Low Voltage limit but greater than Load Dump Low Voltage limit

- Time to correct: 5 minutes
- Corrective Actions include:
 - Non-cost actions
 - *See previous slide*
 - Off-cost generation adjustment
 - All emergency procedures
 - If voltages are decaying to Load Dump limit, shed load to return voltages to Normal Low

362 kV
High Voltage Limit

328 kV
Normal Low Limit

317 kV
Emergency Low
Limit

310 kV
Load Dump
Limit

Example 345 kV Facility



Corrective Actions

Condition: **Actual Voltage** less than Load Dump Low Voltage limit

- Time to correct: Immediate
- Corrective Actions include:
 - Non-cost actions
 - Off-cost generation adjustment
 - All emergency procedures
 - If voltages are at or below Load Dump limit, shed load to return voltages to Normal Low limit

362 kV
High Voltage Limit

328 kV
Normal Low Limit

317 kV
Emergency Low Limit

310 kV
Load Dump Limit

Example 345 kV Facility



Corrective Actions

Condition: **Post-contingency Voltage** exceeds High Voltage limit

- Time to correct: 30 minutes
- Corrective Actions include:
 - Capacitor/Reactor switching
 - Tap changer adjustment
 - Generator/synchronous condenser excitation adjustment
 - Switching lines/cables out of service
(*Facilities 500 kV & Above)

362 kV
High Voltage Limit

328 kV
Normal Low Limit

317 kV
Emergency Low Limit

310 kV
Load Dump Limit

Example 345 kV Facility



Corrective Actions

Condition: **Post-contingency Voltage** less than Normal Low Voltage limit but greater than Emergency Low Voltage limit

- Time to correct: not applicable
- Corrective Actions include:
 - Non-cost actions only
 - This situation is considered a Trend and should be monitored, however, no off-cost measures will be taken to correct

362 kV
High Voltage Limit

328 kV
Normal Low Limit

317 kV
Emergency Low Limit

310 kV
Load Dump Limit

Example 345 kV Facility



Corrective Actions

Condition: **Post-contingency Voltage** less than Emergency Low Voltage Limit but greater than Load Dump Low Voltage Limit

- Time to correct: 15 Minutes
- Corrective Actions include:
 - Non-cost actions
 - Off-cost generation adjustment
 - All emergency procedures EXCEPT load dump

362 kV
High Voltage Limit

328 kV
Normal Low Limit

317 kV
Emergency Low Limit

310 kV
Load Dump Limit

Example 345 kV Facility



Corrective Actions

Condition: **Post-contingency Voltage** less than Load Dump
Low Voltage Limit

- Time to correct: 5 Minutes
- Corrective Actions include:
 - Non-cost actions
 - Off-cost generation adjustment
 - All emergency procedures
 - Shed load pre-contingency if necessary to avoid voltage collapse (System wide problem)

362 kV
High Voltage Limit

328 kV
Normal Low Limit

317 kV
Emergency Low
Limit

310 kV
Load Dump
Limit

Example 345 kV Facility



Corrective Actions

Condition: **Post-contingency Voltage Drop (%)** exceeds Voltage Drop Warning but is less than Voltage Drop Violation

- Time to correct: N/A
- Corrective Actions include:
 - Non-cost actions only
 - This situation is considered a Trend and should be monitored, however, no off-cost measures will be taken to correct

4 – 6 %
Voltage Drop
Warning

5 – 8 %
Voltage Drop
Violation



Corrective Actions

Condition: **Post-contingency Voltage Drop (%)** exceeds
Voltage Drop Violation

- Time to correct: 15 Minutes
- Corrective Actions include:
 - Non-cost actions
 - Off-cost generation adjustment
 - All emergency procedures
 - Shed load pre-contingency if necessary to avoid voltage collapse

4 – 6 %
Voltage Drop
Warning

5 – 8 %
Voltage Drop
Violation



Voltage Operating Criteria Exercises

Voltage Limit Exercises

- Scenario #1:

Your security analysis program shows that for the loss of the Elmer Unit #1 the 500kV Bus voltage at Elmer would drop to 470 kV. Is this exceeding any post-contingency simulated voltage limit?

If so which one and how long do you have to correct and what actions are used?

Voltage Limit Exercises

- Scenario #2:

Your security analysis program shows that for the loss of the Elmer – Rockford 500 kV Line the Rockford 230 kV Bus voltage drops to 215 kV. Is this exceeding any post-contingency simulated voltage limit?

If so which one and how long do you have to correct and what actions are used?

Voltage Limit Exercises

- Scenario #3:

Your security analysis program shows that for the loss of the Elmer – Wheeler 230 kV Line the Wheeler 230 kV Bus voltage drops to 209 kV. Is this exceeding any post-contingency simulated voltage limit?

If so which one and how long do you have to correct and what actions are used?

Voltage Limit Exercises

- Scenario #4:

Your security analysis program shows that for the loss of the St. John Unit #1 the St. John 230 kV bus voltage will experience a 9% voltage drop. Is this exceeding any post-contingency simulated voltage operating criteria?

If so which one and how long do you have to correct and what actions are used?

Voltage Limit Exercises

- Scenario #5:

The Elmer terminal of the Elmer – Rockford 500 kV Line trips open. As a result the Rockford bus voltage is now 554 kV. Is this exceeding any voltage limit?

If so which one and how long do you have to correct and what actions are used?

Voltage Control with Generators

Voltage Control Background

- Generators are a Major Source of MVARs
 - VAR supply controlled by field excitation
 - VARs don't travel well
 - Use units electrically close to the voltage problem
- Response to Generator Excitation Changes
 - Voltage at output of generator controlled by voltage regulator
 - Normally on automatic control (NERC Standard VAR-002-4.1)
 - If voltage regulator is out of service, eDART ticket is required
 - Can be manually controlled

Adjustments in Generation to Control Voltage

- Response to Generator Excitation Changes
 - Voltage regulator controls excitation
 - System voltage decreases
 - Voltage regulator senses decrease --> Excitation increased by voltage regulator --> VAR generation increases --> Output voltage increases (VAR flow on transmission line increases)
 - System voltage increases
 - Voltage regulator senses increase --> Excitation decreased by voltage regulator --> VAR generation decreases --> Output voltage decreases (VAR flow on transmission line decreases)
 - Power (MW) output not affected by excitation

Generator Automatic Voltage Regulator Status

- Per NERC Standard VAR-002-4.1
 - R3. Each Generator Operator shall notify its associated Transmission Operator of a status change on any generator reactive power resource, including the status of each automatic voltage regulator, power system stabilizer, or alternative controlling device within 30 minutes of the change
 - If the status has been restored within 30 minutes of such change, then the Generator Operator is not required to notify the Transmission Operator of the status change
- Reporting of AVR status and Reactive Capability changes accomplished via eDART generator reporting

Adjustments in Generation to Control Voltage

- Effect of Adjusting MVAR Output of a Single Generator with Radial Load *(A radial system has only one power source for a group of customers)*
 - Increase in excitation
 - MVAR output increases
 - Voltage profile shifts upward
 - Results in voltage increase at generator output and at load bus
 - Effect is reduced further from generator due to MVAR losses on line

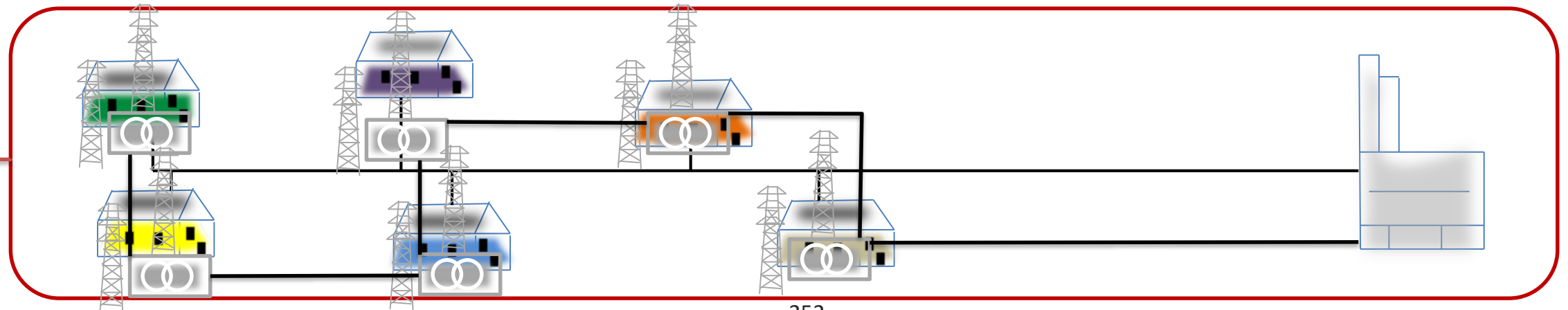

Adjustments in Generation to Control Voltage

- Effect of Adjusting MVAR Output of a Single Generator with Radial Load
 - Decrease in excitation
 - MVAR output decreases
 - Voltage profile shifts downward
 - Results in voltage decrease at generator output and at load bus

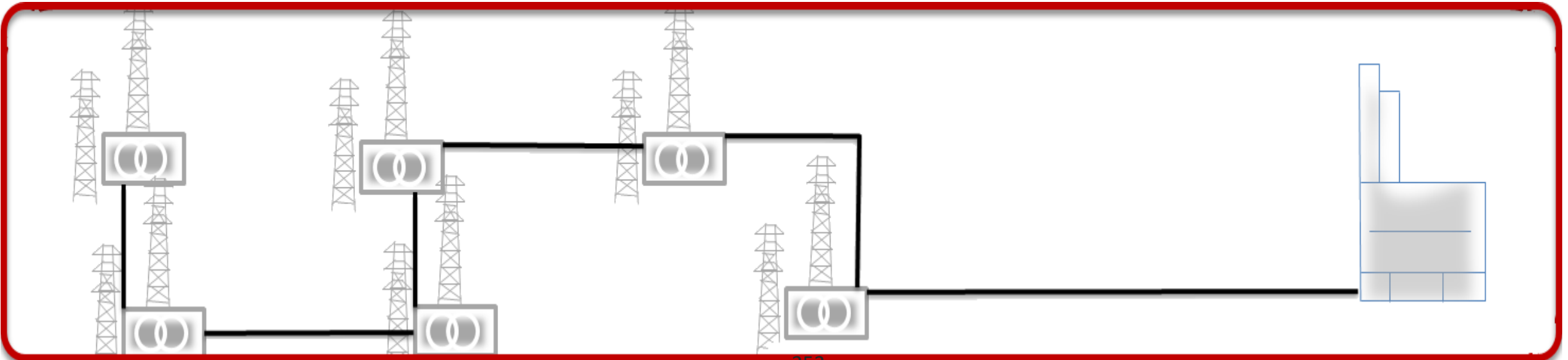

Adjustments in Generation to Control Voltage

- Adjustments of Multiple Units at Single Station
 - Coordinate shifts of multiple units together
 - Otherwise, voltage regulators of other units may increase or decrease excitation to compensate for desired change
 - Results in unwanted VAR flow
 - Result of not adjusting all units
 - Voltage does not change as planned
 - Units may shift to absorbing VARs
 - Units may become under or over-excited

Adjustments in Generation to Control Voltage

- Adjustments in an Interconnected System
 - More complicated due to VAR flows
 - Voltage response
 - Increased VAR supply in local area will cause voltage rise in that area
 - Amount of voltage rise is diminished by VAR flow out of that area
 - Voltage rise is largest near VAR supply
 - Gradually decreases further from VAR supply
 - At some distance and beyond, no voltage effect will be seen

Restrictions and Limitations

- Generating Unit

- Unit Over-excitation

- Limit on field heating, limits MVAR generation
 - Rotor overheating is I^2R heating caused by DC current over-excitation

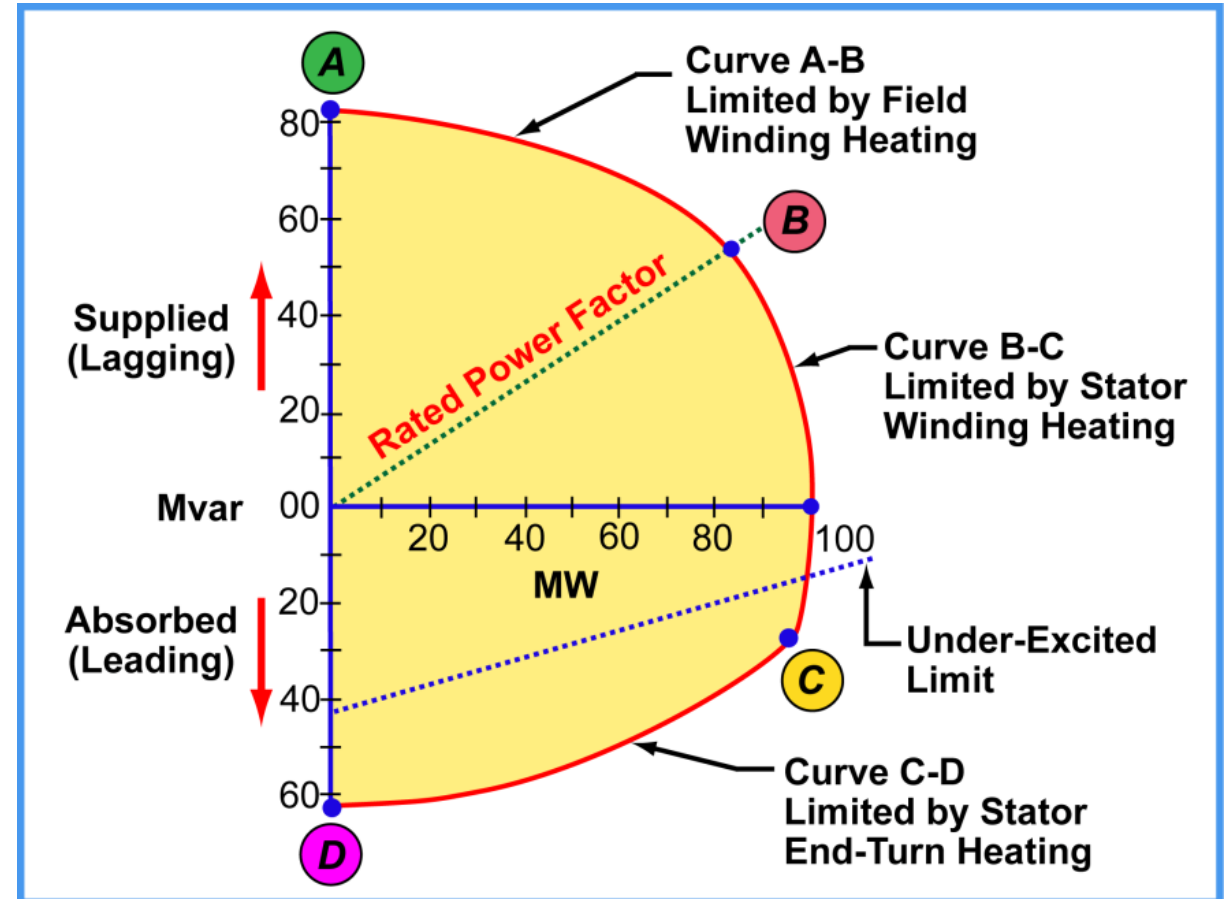

Restrictions and Limitations

- Generating Unit

- Unit Under-excitation

- Limit on end turn heating
 - Unit instability
 - Field strength too weak, unit goes unstable
 - Area Stability, Salem, PS South

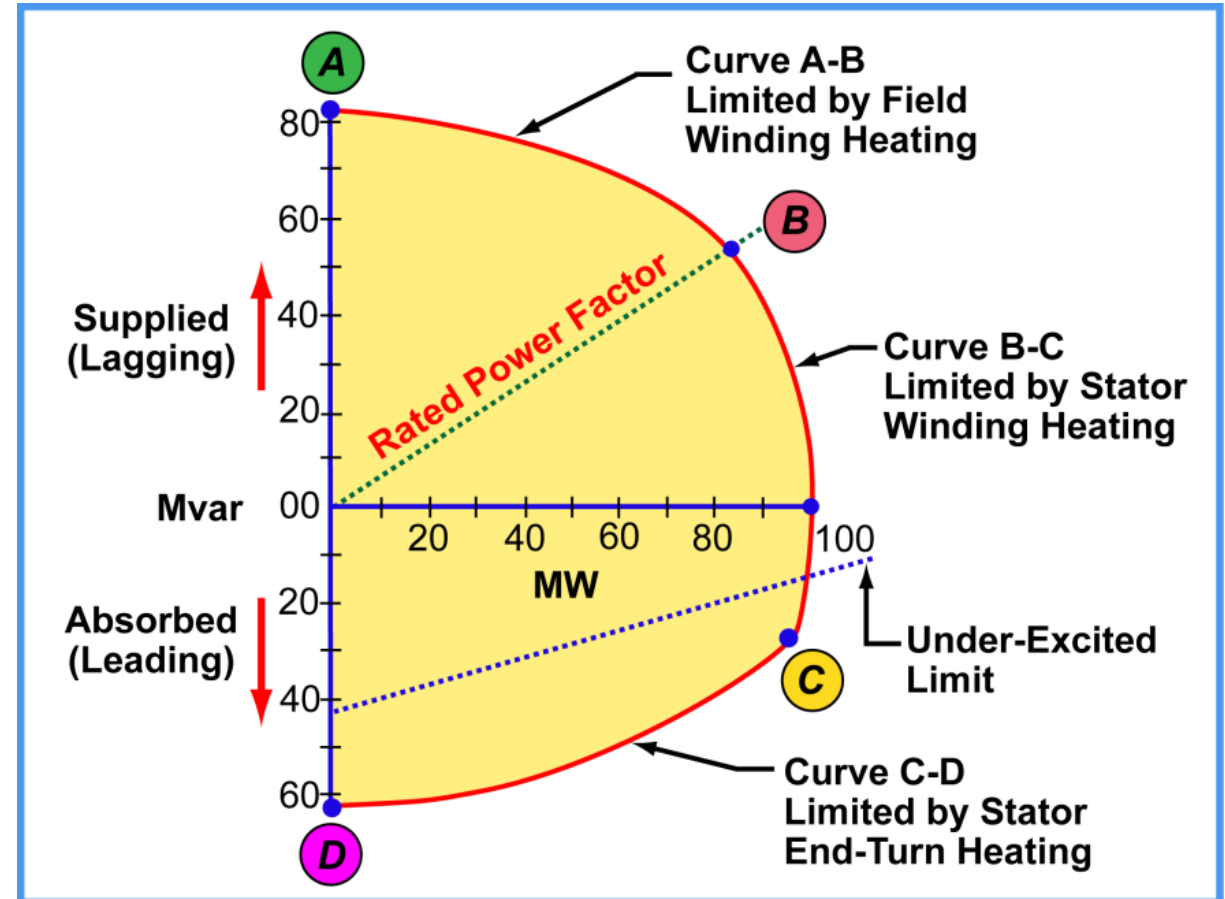

Restrictions and Limitations

- Generating Unit
 - MVAR output limited by D-curve
 - May be limited by auxiliary bus voltage limits
 - Voltage regulator limits
 - Voltage regulator operates only within designed voltage limits
 - Designed to limit amount of MVARs that can be generated
 - Power factor limits
 - Units are limited to operating within certain pf limits
 - MW tradeoff
 - Above certain MVAR output, MW must be traded to get additional MVAR output

Restrictions and Limitations

- Power System
 - Must coordinate shifts in generation to obtain desired MVAR flows and voltage adjustments
 - Should coordinate generation voltage adjustments with switchable sources (capacitors and reactors)
 - Do not remove all VAR reserve from a generating unit

Voltage Schedules

- NERC Standard VAR-001-5:
 - Each TOP shall:
 - Specify a voltage or reactive power schedule (setpoint and bandwidth)
 - Provide the schedule to the GOP, and direct the GOP to follow the schedule with its AVR in service (automatic)
 - Provide the GOP with the notification requirements for deviations from the schedule
 - Provide the criteria used to develop the schedules
- The TO/TOP Matrix identifies shared or assigned responsibilities

Voltage Schedules

- **PJM:**

- Requires the following subset of generators to follow voltage schedules:
 - Individual generating units > than 20 MVA
 - Generators that aggregate to 75MVA or greater that are connected to a common bus
 - Black start generators
 - Any other Generation Owners/Operators that request a voltage schedule

Overview

- Generator Voltage Schedules through PJM's eDART application ensures consistent tracking and reporting protocols for communication between PJM, TOs and GOs concerning generator voltage schedules
- Annually, PJM shall initiate a voltage schedule review
 - TOs shall review and update each schedule with the GOs acknowledgement
- Allows TOs to specify, and PJM to approve, Voltage Schedules for all generating units to include:
 - Submitting a new ticket, Editing an existing ticket, handling of exemptions, reporting, processing and seasonal verification

Overview

- Generators that require a Voltage Schedule:
 - Individual generating units > 20 MVA
 - Generators aggregating to 75 MVA or > connected to a common bus
 - Black start generators
 - Any other GOs that request a voltage schedule
- Generators added to eDART that meet the above criteria will have a blank “Needs Schedule” ticket automatically entered requiring a new Voltage Schedule ticket to be submitted by the TO

Overview

- Each Voltage Schedule ticket shall contain:
 - A target voltage schedule
 - Upper and lower bandwidths
 - The regulated transmission bus
- Each schedule can either be PJM’s default voltage schedule, or a schedule as designated by the local Transmission Owner

	PJM Default Generator Voltage Schedules								
Voltage Level (kV)	765	500	345	230	161	138	115	69	66
Schedule (kV)	760.0	525.0	350.0	235.0	164.0	139.5	117.0	70.0	67.0
Bandwidth (+/- kV)	+/-10.0	+/- 8.0	+/- 7.0	+/- 4.0	+/- 4.0	+/- 3.5	+/- 3.0	+/- 2.0	+/- 1.5

Overview

- A voltage schedule can be based on the TO's specifications:
 - Voltage
 - Reactive Power
 - Power Factor
 - Manual (TO Exemption)

AVR Operating Mode	Expected Generator Response
Automatic controlling voltage (voltage schedule)	Reactive output varies based on the grid system needs to maintain the reference voltage within the assigned voltage schedule's bandwidth up to the reactive capabilities of the generator. This is the standard voltage control operating mode for most generators in PJM.
Automatic controlling MVARs (MVAR schedule)	Reactive output remains steady based on scheduled MVARs
Automatic controlling power factor (power factor schedule)	Reactive output varies based on the real power output of the generator to maintain a constant ratio of real power versus apparent power (constant power factor)
Manual	Reactive output varies based on the manual adjustments made by the plant operator

Voltage Schedule Responsibilities

TO

Specify

TO-Specified or PJM Default Voltage Schedule

Specify Voltage Schedule Type: Voltage, Power Factor, or Reactive Power

Provide Target Voltage Schedule & Tolerance Band

Attach Voltage Schedule Letters (Optional)

Submit Exemption Requests

PJM

Review

Maintain List of Applicable Units (M-03 Sect. 3.11)

Review and Acknowledge Voltage Schedules

Coordinate adjacent TO/External Voltage Schedules

Approve Exemption Requests

Initiate **Annual** Voltage Schedule Reviews

GO

Acknowledge

Acknowledge Voltage Schedules

Provide feedback on Voltage Schedule through GO Comments

Voltage Schedule Ticket Process

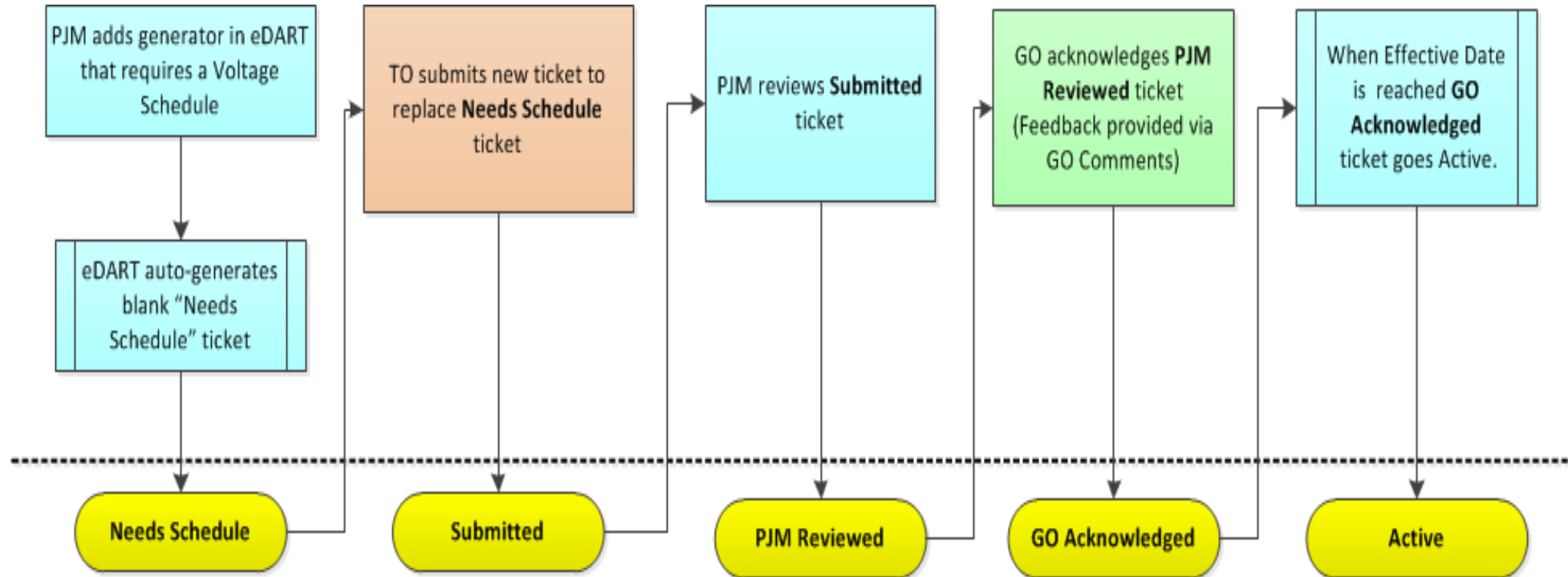

Accessing the Voltage Schedules Ticket (GO)

- Feedback
- My eDART
- Upload
- Download
- NEW Upload
- NEW Download
- Gen. Tickets**
- Trans. Tickets
- Network Model
- Black Start
- TERM
- Reactive Reserve
- Instantaneous Reserve Check
- Minimum Gen. Report
- PJM Status Report
- NERC Data
- Facility Data

- After logging into eDART, click on the Generation| Tickets Button to access the Generator Tickets Main Menu.
- The Generator Outage Main Menu is shown on the right.

- Click on the Voltage Schedule button and you will arrive at the Voltage Schedule Page
- Button will be red if there is a required action by the GO

Generator Tickets Main Menu

Summer Peak Period Maintenance Margin Season
Start: 06/10/2019 End: 09/06/2019

Current Maintenance Margin	
Mid-Atlantic	N/A
Western-Southern	N/A

Create New Ticket Opportunity Window View/Revise Ticket

	MW	Volt. Reg.	MVAR	Governor	MVAR Test	PSS
Submitted Tickets	8	7	33	5	35	4
Revised Tickets	10	0	2	0	1	0
Current Tickets	21	3	5	1	2	1
Approved Tickets	24	0	4	0	0	1
Future Tickets	3	0	0	0	0	0
Approved No Start	21	0	0	0	0	1
Active Beyond End	21	3	5	1	2	1
Recalled Tickets	0					
Forced Tickets						
Tickets History						

Owners Report Maint. Margin Log D-Curve Report

Black Start Test Upload Black Start Test Download Black Start Calculator

GO Summary **Voltage Schedules**

Starting Screen

Voltage Schedule (as of 11/15/2018 03:16)

Needs Schedule (9 / 38)
 Submitted (2 / 0)
 Pending Review (0 / 1)
 TO Review (1 / 0)
 PJM Reviewed (1 / 0)
 GO Acknowledged (0 / 0)
 Saved (0 / 0)
 Active (7 / 1)
 Completed (0 / 0)
 Canceled by TO (0 / 0)
 Canceled by PJM (12 / 1)
 In Effect
 Canceled Prev. Ack. (1 / 0)
 Late (2 / 0)
 GO Comments (0 / 0)
 Trans. Owner:
 Unit Type:
 Gen. Owner:
 Unit Name:
 Trans. Zone:
 Ticket #:
 From Date: To Date:
 Incl. Hist: Eff. Date: TO Date: GO Date:

Voltage Schedule Tickets

Ticket #	GO Company TO Company	TR Zone	Unit Name Equipment Name Bus Name	Voltage Schedule Type	Normal			Light			Heavy			Effective Date	Status	Comments
					Target	Lower	Upper	Target	Lower	Upper	Target	Lower	Upper			
3006	Baltimore Gas and Electric Company Baltimore Gas and Electric Company	BC	BLUE CREEK 1 WESTPORT 13 KV CT 05 Blue Creek Bus 1	Voltage(KV)	13.0	11.0	15.0	13.0	11.0	15.0				11/30/2018	Active	TO: <input type="text"/> GO: <input type="text"/> PJM: <input type="text"/>
2679	Baltimore Gas and Electric Company Baltimore Gas and Electric Company	BC	BLUE CREEK 3 WESTPORT 13 KV CT 05 bus b	TO Exempt										11/01/2018	Active	TO: <input type="text"/> GO: <input type="text"/> PJM: <input type="text"/>
2642	Baltimore Gas and Electric Company Baltimore Gas and Electric Company	BC	BRANDON SHORES 2 BRANDONS 24 KV GEN 02 Brandon Shores Bus 2	Reactive(MVAR)	110.0	100.0	130.0							11/01/2018	Active	TO: PJM is entering TO comments for Active GO: PJM is entering GO comments for Active PJM: PJM Comments
3007	Baltimore Gas and Electric Company Baltimore Gas and Electric Company	BC	CALVERT CLIFFS 2 CALVERTC 22 KV GEN 02	PowerFactor(PF)	1.00	0.98	0.98							11/06/2018	Active	TO: Test PF Schedule GO: No concerns with this Voltage Schedule PJM: <input type="text"/>

Filter Menu

Command Menu

Voltage Schedule Tickets

Edit Button

Ticket Details

Voltage Schedule Ticket Details (as of 11/15/2018 03:58)

Ticket #	GO Company TO Company	TR Zone	Unit Name Equipment Name Bus Name	Voltage Schedule Type	Normal			Light			Heavy			Effective Date	Status
					Target	Lower	Upper	Target	Lower	Upper	Target	Lower	Upper		
3030	GO Company A	XX	Test Unit 1	Voltage	525.0	5.0	5.0						11/17/2018	Submitted	
	TO Company X		TEST 500 KV UNIT 1	(KV)		520.0	530.0								
			Test 500 kv Bus A	X											

TO Comments: Test ticket

GO Comments:

PJM Comments:

Needs Schedule (9 / 38)
 Submitted (2 / 0)
 Pending Review (0 / 1)
 TO Review (1 / 0)
 PJM Reviewed (1 / 0)
 GO Acknowledged (0 / 0)
 Saved (0 / 0)
 Active (7 / 1)
 Completed (0 / 0)
 Canceled by TO (0 / 0)
 Canceled by PJM (12 / 1)
 In Effect
 Canceled Prev. Ack. (1 / 0)
 Late (2 / 0)
 GO Comments (0 / 0)

Trans. Owner:
 Unit Type:
 Gen. Owner:
 Unit Name:
 Trans. Zone:
 Ticket #:
 From Date: To Date:
 Incl. Hist. Eff. Date TO Date

Comment Entry

Ticket Status

Ticket Details

Voltage Schedule Ticket Details (as of 11/15/2018 05:16)

Ticket #	GO Company TO Company	TR Zone	Unit Name Equipment Name Bus Name	Voltage Schedule Type	Normal			Light			Heavy			Effective Date	Status	
					Target	Lower	Upper	Target	Lower	Upper	Target	Lower	Upper			
3115	GO Company A	XX	New Test Unit 1	Voltage	525.0	8.0	8.0							11/21/2018	Submitted	
	TO Company X		TEST 500 KV UNIT 1	(KV)		517.0	533.0									
			TEST 500 KV West Bus													

TO Comments: GO Comments: PJM Comments:

Needs Schedule (9 / 38)
 Submitted (3 / 0)
 Pending Review (0 / 1)
 TO Review (1 / 0)
 PJM Reviewed (1 / 0)
 GO Acknowledged (0 / 0)
 Saved (0 / 0)
 Active (7 / 1)
 Completed (0 / 0)
 Canceled by TO (0 / 0)
 Canceled by PJM (12 / 1)
 In Effect
 Canceled Prev. Ack. (1 / 0)
 Late (2 / 0)
 GO Comments (0 / 0)

Trans. Owner: Unit Type:
 Gen. Owner: Unit Name:
 Trans. Zone: Ticket #: 3115
 From Date: To Date: Incl. Hist. Eff. Date TO Date GO Date

Voltage Schedule Tickets

Ticket #	GO Company TO Company	TR Zone	Unit Name Equipment Name Bus Name	Voltage Schedule Type	Normal			Light			Heavy			Effective Date	Status	Comments
					Target	Lower	Upper	Target	Lower	Upper	Target	Lower	Upper			
3115	GO Company A TO Company X	XX	New Test Unit 1 TEST 500 KV UNIT 1 TEST 500 KV West Bus	Voltage(KV)	525.0	517.0	533.0							11/21/2018	Submitted	TO: <input type="text"/> GO: <input type="text"/> PJM: <input type="text"/>

Required Entries

Optional Entries

Ticket Details

- The “Effective Date” is the day the ticket is in effect:
 - Applies to all four types of Voltage Schedules
 - The date cannot be the day the ticket was submitted
 - Earliest “Effective Date” allowed is the next day (submission date + 1 day)
 - No two tickets can start on the same day.
 - Error returned if user submits a future ticket with the same effective date as one that already exists for the unit.



Acknowledging a Reviewed Voltage Schedule Ticket

- A ticket in “GO Acknowledged” status will turn “Active” once the effective date of the ticket has been reached
- Old Active Voltage Schedule tickets are automatically “Completed” once a new GO Approved ticket turns active by reaching its Effective Date.
- Active tickets are highlighted by a mint-green tab on the Voltage Schedule Tickets listing

Capacitors and Reactors

Capacitors and Reactors

- Peak Loads
 - Maximum load period cause large voltage drops across system due to heavy MVAR flow
 - Maximum VAR loading degrades voltage support
 - System voltages are lowered
 - Voltages most affected near VAR loads
 - Voltages can be improved by increasing VAR supply as close as possible to loads
 - Switch reactors out of service
 - Switch capacitors into service

Capacitors and Reactors

- Light Load Periods
 - Real power flows are minimized
 - Fixed capacitors and system capacitance dominate
 - System voltages rise
 - Customer voltages may exceed upper limits
 - Voltages can be lowered by adding VAR sinks to the system
 - Switch capacitors out of service
 - Switch reactors into service

Capacitors and Reactors

- Capacitors
 - Supply VARS
 - Locating capacitors near the load has two effects
 - Reduces system VAR flow to the load
 - Reduces line loading
 - Reduces voltage drops due to IX component
 - Provides additional VARs to the system which causes voltage to rise

Automatic Switching of Capacitors

- Programmable Logic Controller

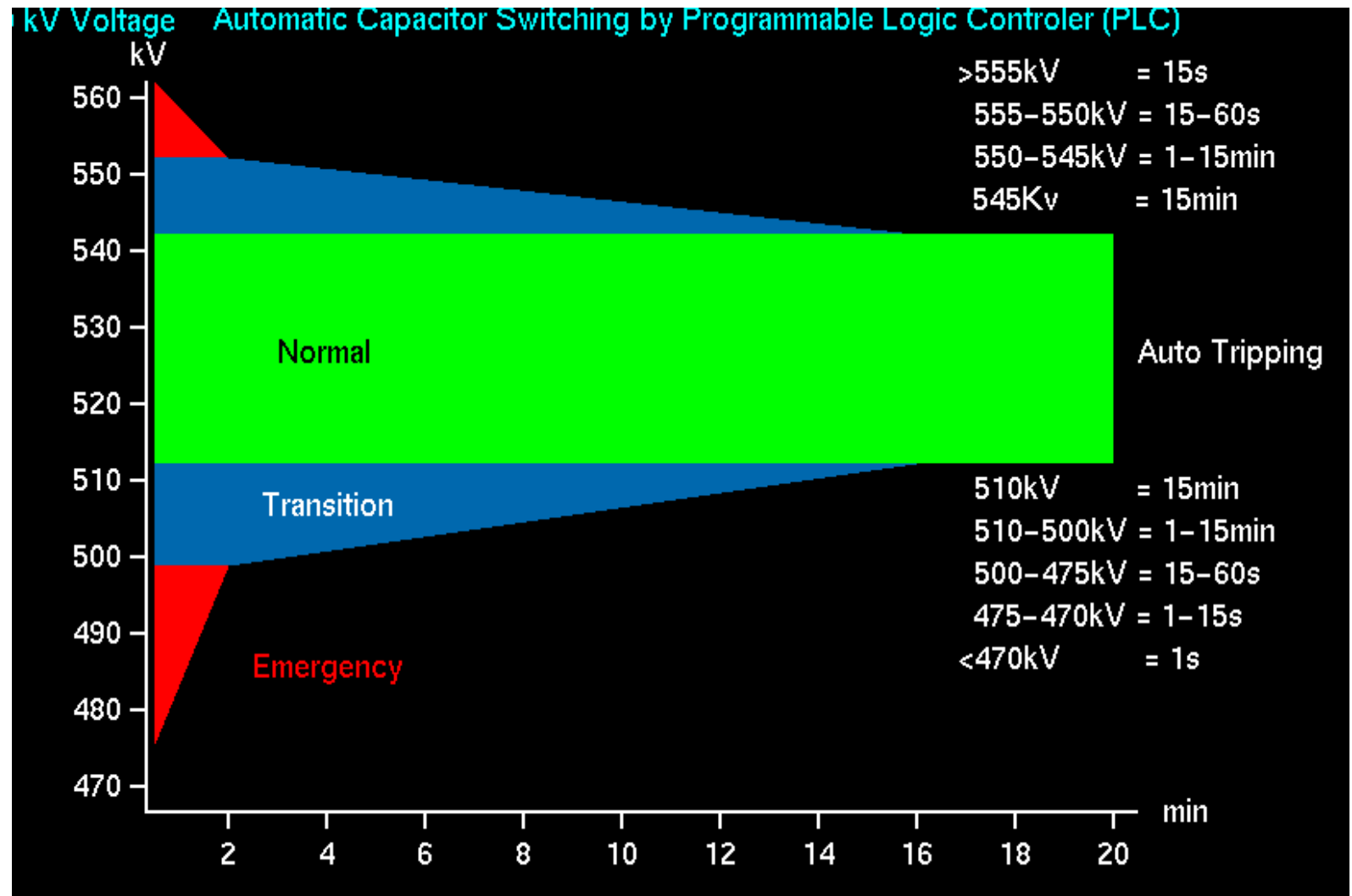

Capacitors and Reactors

- Reactors

- Reactors serve as VAR sinks
 - Absorb VARs from the system
 - Cause voltage to decrease
- Placed on transmission system
 - Most effective when close to VAR sources
 - End of transmission cables
 - Prevent unnecessary VAR flows

Capacitors and Reactors

- Static VAR compensators
 - Automated impedance matching device
 - Set of electrical devices for providing fast-acting reactive power on high-voltage electricity transmission networks
 - No significant moving parts
 - Comprised of one or more banks of fixed or switched shunt capacitors or reactors
 - At least one bank is switched by thyristors

Capacitors and Reactors

- Static VAR compensators
 - Used in two main situations:
 - On the power system, to regulate transmission voltage
 - Near large industrial loads, to improve power quality

Capacitors and Reactors

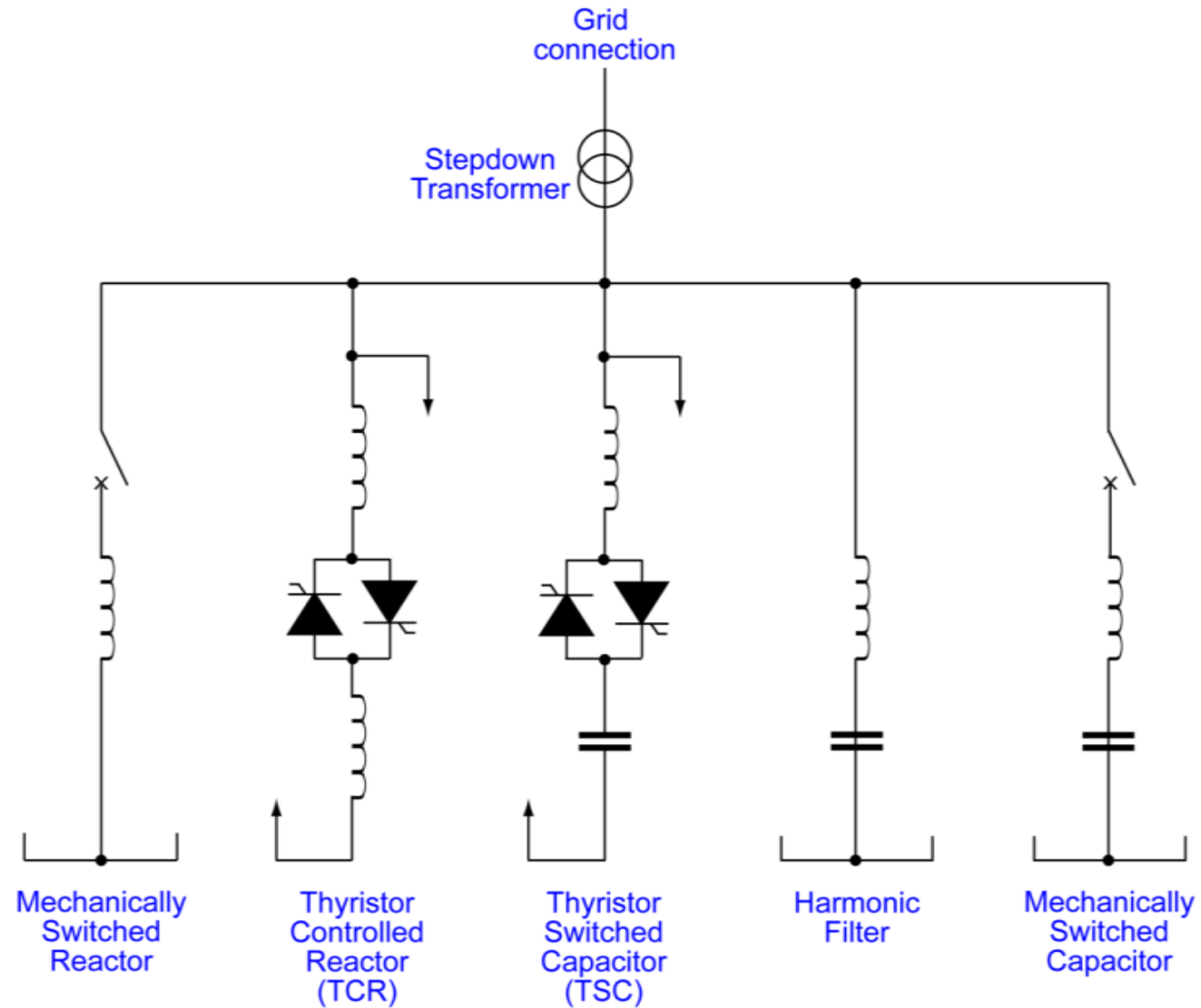

Limitations and Restrictions

- Switching Schedules
 - Many capacitors and reactors are switched by schedule
 - Fixed capacitors and reactors
 - Time switched
 - Load switched
 - kVAR load switched
 - Voltage switched
 - Manual switched
 - Programmable Logic Controller (PLC)

Capacitor Switching Philosophy

- PJM, in coordination with the TOs, attempts to minimize capacitor switching when possible
- Switching of reactive resources 230 kV and above must be done at the direction of the TOP
 - Automatic capacitor switching capability on facilities 230 kV and above must be documented in Manual 3, Section 3
 - Switching reactive devices connected to 138 kV and below may be done without notifying PJM
 - However TOs should evaluate the impact of adding and removing reactive devices as well as adjusting LTCs so as not to violate any voltage limits

Reactive Resource Outages

- The Transmission Owners are responsible for reporting outages on all facilities contained within the Transmission Facilities List Database
 - These lists include reactive resources and can be found on PJMs website at the following link:
 - <http://www.pjm.com/markets-and-operations/transmission-service/transmission-facilities.aspx>
 - In addition to complete outages, if a capacitor bank's rated MVAR capability has been significantly changed:
 - Should also be communicated to PJM for modeling purposes as well as updated in the Transmission Owner's EMS model

Limitations and Restrictions

- Capacitor is Less Effective as Voltage Decreases
 - MVAR output proportional to square of voltage
 - When needed most, capacitors provide the least support

$$MVAR \text{ Output} = MVAR_{Rated} \left(\frac{V_{Actual}}{V_{Rated}} \right)^2$$

As an example, if a 100 Mvar capacitor (rated 100 Mvar at 345 kV) is in service at a voltage of 340 kV the capacitor output is:

$$MVAR \text{ Output} = 100 \text{ MVAR} \times (340\text{kV}/345\text{kV})^2 = 97 \text{ MVAR}$$

Transformer Load Tap Changer Operations

Voltage Control with LTCs

- Load Tap Changer (LTC) or Tap Changer Under Load (TCUL) Operation:
 - Weak bus vs. strong
 - If a transformer is connected to a “weak” reactive power source, it will not be effective in controlling the voltage on the other winding
 - When it “pulls” VARs from the primary, the primary voltage drops
 - This offsets any gains that might have been made to the secondary voltage

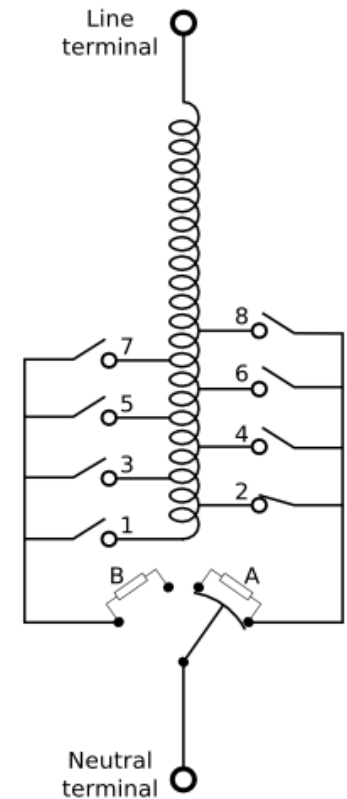

A mechanical **under- load tap changer (ULTC)** design, changing back and forth between tap positions 2 and 3

Strong Bus Example

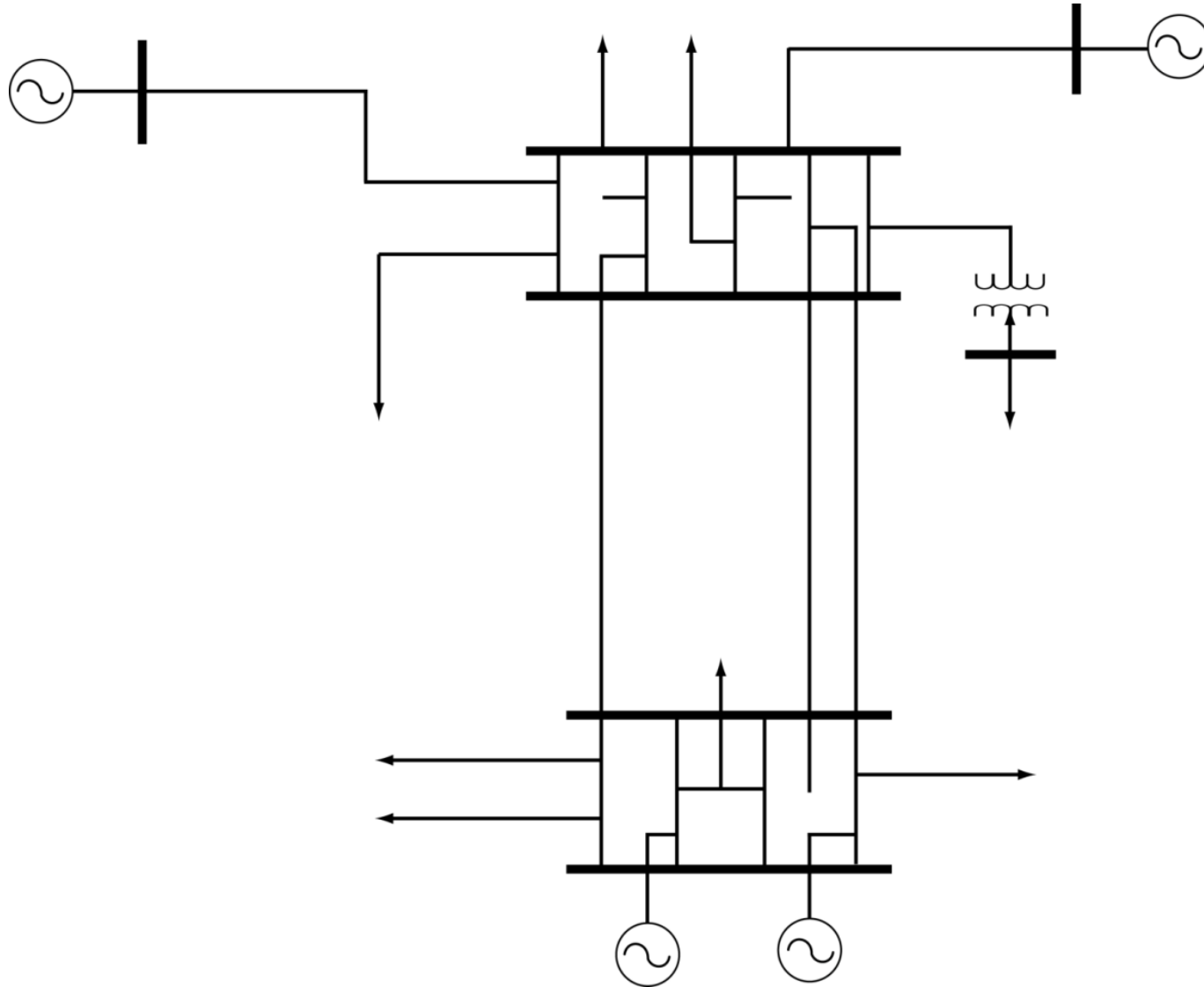

Weak Bus Example

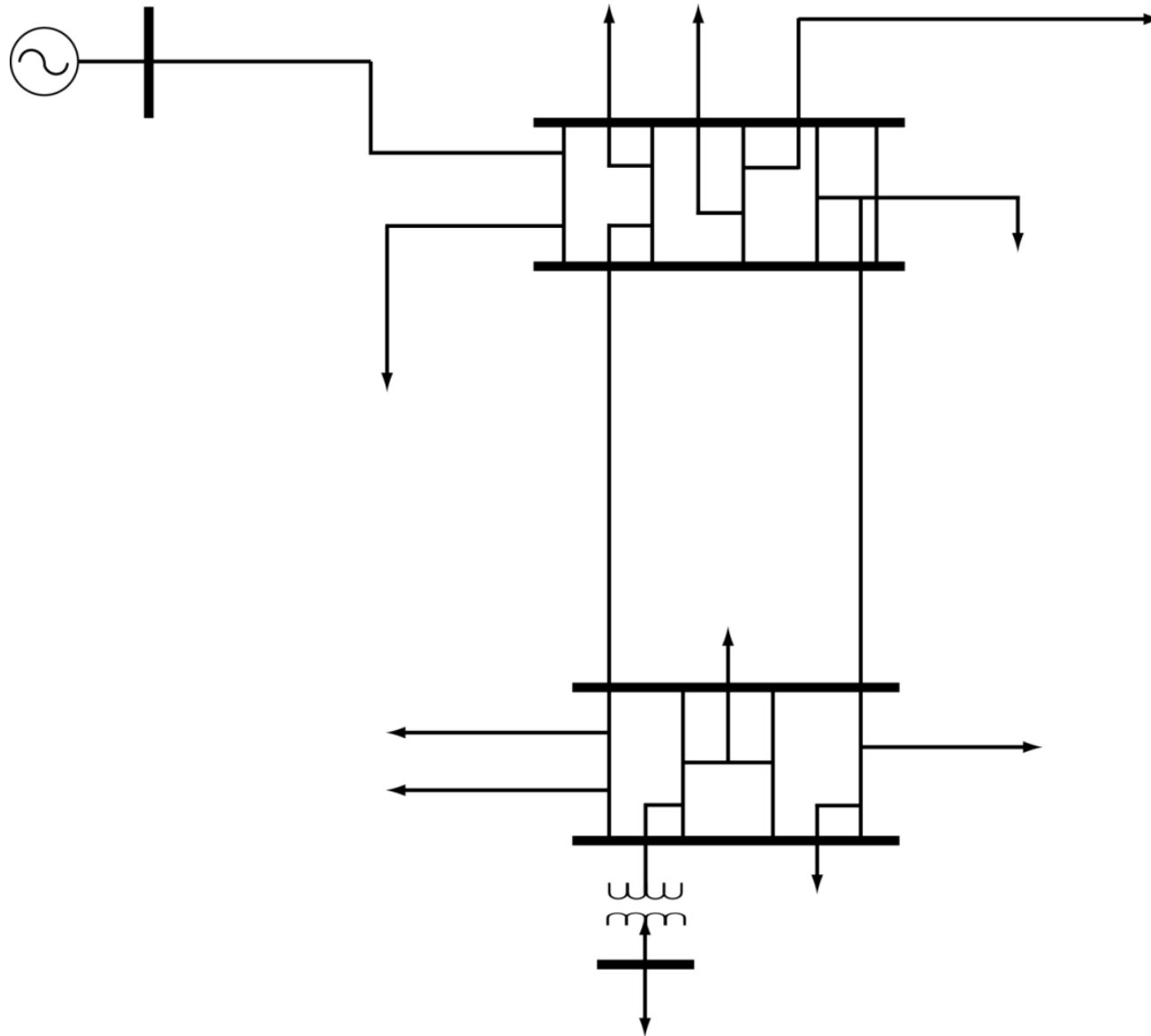

Tap Change Operation

- Maintain System Voltage Profile
 - Transformer tap changers act as VAR shovels
 - Adjust voltage on both sides of transformer
 - Most adjustments to maintain constant voltage at sub-transmission and distribution levels are accomplished by automatic load tap changing
- Correct Voltages Which Exceed Limits
- Reduce Undesirable MVAR Flow
 - VAR flow control within a power system
 - Adjust VAR flow through a transformer
 - Reduce losses

Effects of Tap Change Operation on the Power System

- Effect on Transmission Line Voltage Profile
 - If tap position is referenced to the low side voltage:
 - Voltage profile shifts upward when tap is raised
 - Voltage profile shifts downward when tap is lowered
 - Percent shift of tap position results in equal shift in percent voltage at transformer terminals

Effects of Tap Change Operation on the Power System

- Effect of Location of Transformer on System Voltages
 - Effect of tap change is determined by how close transformer is to VAR sources and VAR loads
 - Magnitude of voltage change determined by:
 - Distance of tap changer from VAR source or VAR load
 - Tap change will have greater effect near source and less effect away from source
 - Magnitude of VAR source or VAR load

Effects of Tap Change Operation on the Power System

- Effect of Location of Transformer on System Voltages

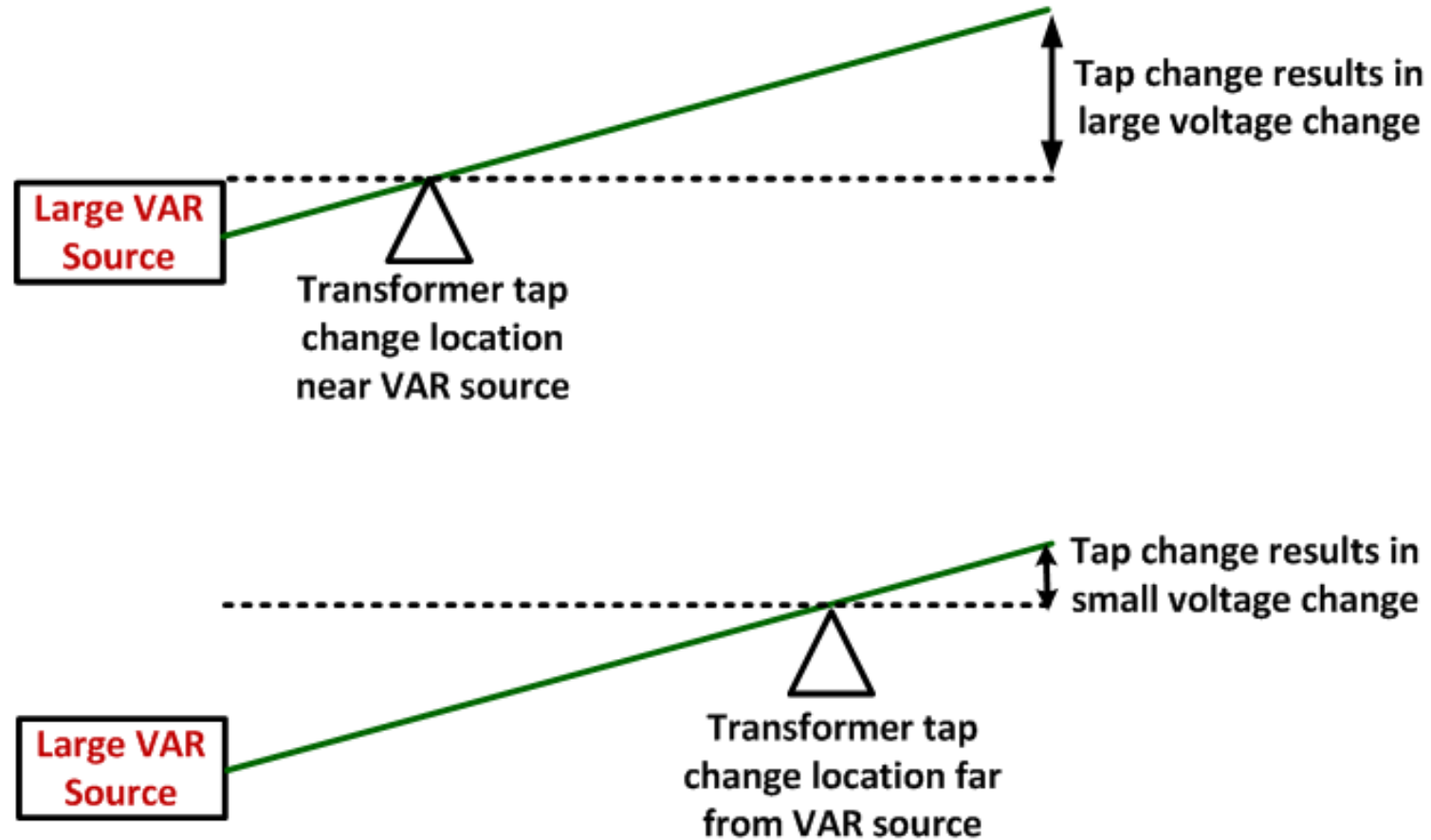

Restrictions and Limitations

- Effect on Interconnected Voltages
 - On interconnected system, changing voltage at one location will also affect interconnected voltages
 - Cannot adjust single individual voltage due to interconnected nature of system
 - Generally must change all taps into an area to achieve the desired effect on the voltage
 - Must observe effects of a tap change on surrounding voltages close to tap change and coordinate tap moves

Restrictions and Limitations

- Unwanted VAR Flows
 - Shifting voltages can cause unwanted VAR flows

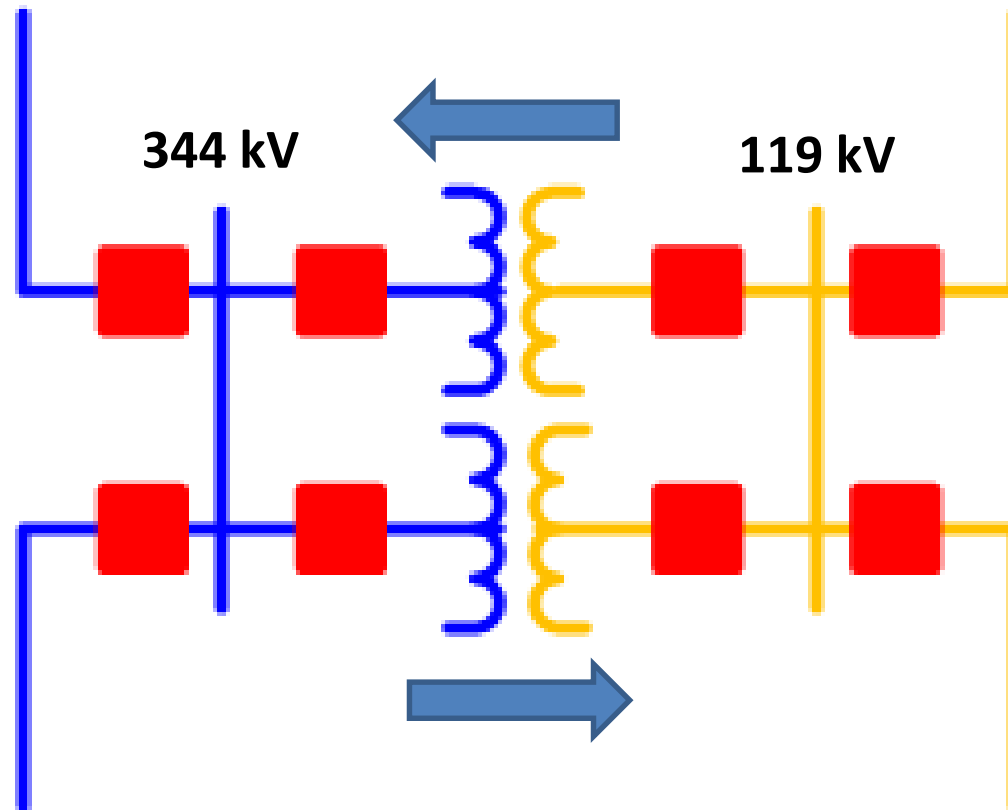

Restrictions and Limitations

- Summary of Restrictions and Limitations
 - Use voltage schedule to determine need to change voltage
 - Coordinate tap changes
 - Transformers in parallel must be balanced to prevent unwanted VAR flows
 - Change of one voltage must be coordinated with interconnected voltages

PAR Operation to adjust voltage

- Phase Angle Regulators (PARs) change the power system phase angle at their location, allowing power flows to be regulated
 - All though they don't directly control voltage, they can have an impact on the voltage profile in the area they are located
 - If you increase the flow on parallel lines by adjusting the tap of a PAR, those lines will consume more reactive power to support the increased MW flow
 - This could lead to a decrease in voltage in the area of those flows if there are not any local reactive resources

Generator Reactive Testing

Generator Reactive Testing

- Reactive capability testing:
 - The objective of reactive capability testing is to improve transmission system reliability by accurately determining generator/synchronous condenser reactive capability on a regular basis
 - Demonstrates reactive capabilities for those conditions where reactive reserves or voltage control would be required
 - Coordinated between all affected parties to minimize impact on system conditions
 - PJM
 - Testing facility
 - Local Transmission Owner(s)

Reporting Reactive Capability Data to PJM

1. A minimum of two curve points must be provided
2. A maximum of eight curve points may be provided
3. The “Unit Maximum Net MVAR Limit” must be greater than (or equal to) the “Unit Minimum Net MVAR Limit” for each curve point
4. The “Unit Minimum, Unit Maximum Net MVAR Limit” may be equal for any number of adjacent curve points
5. The “Unit Net MW Output” must be increasing from the first to the last point
6. Company can either test or apply the best engineering judgment to construct D-curve at min load points

General Requirements

Applies to:

- Individual generators > 20MVA
- Generator plants > 75MVA total
- Black Start
- Synchronous Condensers > 20MVA

Timing Requirements:

- 20% of applicable facilities annually
- 100% of applicable facilities within a 66 month period (Once every 5 years)

TESTING REQUIREMENTS SUMMARY

UNIT TYPE	MW OUTPUT	MVAR OUTPUT	TEST DURATION
FOSSIL, HYDROELECTRIC & BLACKSTART	MAX	MAX LAG	ONE HOUR
	MAX	MAX LEAD	WHEN LIMIT REACHED
	MIN	MAX LAG	WHEN LIMIT REACHED
	MIN	MAX LEAD	WHEN LIMIT REACHED
SYNCHRONOUS CONDENSER or GENERATOR THAT OPERATES IN THE SYNCHRONOUS CONDENSING MODE TO PROVIDE REACTIVE SUPPORT	-	MAX LAG	ONE HOUR
	-	MAX LEAD	WHEN LIMIT REACHED
NUCLEAR	MAX	MAX LAG	ONE HOUR
	MAX	MAX LEAD	WHEN LIMIT REACHED
VARIABLE (E.G. WIND AND SOLAR) (Testing done with at least 90% of turbines or inverters on line)	VARIABLE	MAX LAG	WHEN LIMIT REACHED
	VARIABLE	MAX LEAD	WHEN LIMIT REACHED

Reactive Capability Testing – Scheduling the Test

- Prior to scheduling the test, the MOC (Unit Owner) shall confirm with PJM RE that MW and MVAR data is being provided to PJM via ICCP
 - Identify/resolve any issues prior to scheduling the test
- Any scheduled (or unscheduled) maintenance on the unit must be completed, and all eDART tickets closed prior to scheduling the MVAR test



Generator Reactive Testing

- Test Scheduling
 - Proposed testing dates/times should be communicated via eDART to PJM Dispatch, PJM Reliability Engineer and the TO no later than noon 3 business days prior to the test
 - Allows testing to be incorporated into the day-ahead studies
 - Test notification shall be submitted using a “MVAR Test” Ticket
 - Test duration
 - Type of test that is planned to be performed
 - Any additional relevant information for the test

Reactive Capability Testing – Scheduling the Test

- MOC (Unit Owner) Actions:
 - Submit an eDART no later than 3 business days prior to the test
 - Create a “MVAR Test” ticket
 - Specify duration of test
 - Description of the test type to be performed
 - Any other relevant information
 - Transmission Owner(s) (TOs) and PJM Reliability Engineer (RE) will ensure the impacts of the testing are factored into the day-ahead studies
 - Shorter Notification times will be considered if PJM/TOs can ensure limits will not be violated

Reactive Capability Testing – What does PJM do?

- PJM Actions:
 - PJM RE and Power Dispatcher will review test results ensuring there is no conflict between the testing and any planned transmission outage
 - PJM will suggest a more appropriate date for the test, if necessary
 - PJM RE and Power Dispatcher will review and approve the test in accordance with the established PJM procedure
 - PJM RE will ensure that PJM dispatch is aware of scheduled testing and communicate the pre-studied mitigating action plan to the PJM Control Room Staff
 - Once the PJM RE is contacted by the MOC or TO, they will contact all impacted TOs in order to initiate the transmission operator's study process

Reactive Capability Testing – What does PJM do?

- PJM Actions:
 - PJM RE will:
 - Verify the expected unit output levels with the MOC, or TO, and ensure that the AVR is in service
 - Re-evaluate the pre-studied mitigating action plan prior to test commencement and communicate any adjustments to the impacted entities
 - Discuss possible mitigation strategies with the impacted TOs
 - Contact the MOC, or TO, no later than two hours prior to testing to inform them whether mitigation steps will be required
 - Coordinate with the appropriate MOCs and TOs in order to implement the selected mitigation strategy

Reactive Capability Testing – What does PJM do?

- PJM Actions:
 - PJM RE will:
 - Coordinate with the TO and MOC in making MVAR output step changes with the testing unit
 - Contact the impacted entities if the testing must be cancelled or rescheduled
 - Coordinate the exit strategy implementation of the exit strategy with the MOCs and TOs, if required
 - Coordinate all actions and communications between MOCs and TOs

Reactive Capability Testing – What do the TOs do?

- Transmission Owner Actions:
 - TOs conduct studies in accordance with established company procedure in order to determine the effect of scheduled testing on their systems
 - The TO should contact the PJM RE with any possible concerns regarding the scheduled testing
 - Prior to studying the test, the TO will verify, with the PJM RE and the generating station or synchronous condenser station, the expected MW and MVAR output levels of the unit during testing, and ensure that the AVR is in service
 - The TO will contact the PJM RE no later than 2 hours and 15 minutes prior to the test start time in order to discuss study results and the mitigating steps required, if any

Reactive Capability Testing – What do the TOs do?

- Transmission Owner Actions:
 - The TOs will discuss, coordinate, and implement any actions necessary as required by mitigation strategies with PJM prior to the start of testing
 - The TO will communicate MVAR output step changes to the testing unit in coordination with PJM. In general, MVAR step changes should be no greater than 100 MVAR increments
 - If testing must be canceled or rescheduled, the TO will inform PJM RE as soon as possible
 - The TO will coordinate their portion of the exit strategy with PJM, and coordinate all actions through the PJM RE or Power Dispatcher

Generator Reactive Testing

- Communication and Coordination
 - MOC/GO (TO for Synchronous Condenser testing)
 - Coordinate and implement mitigations steps, and exit strategy as required
 - Notify PJM at least three hours prior to the start of the scheduled testing in order to initiate the real-time study process
 - If studies indicate actual or post-contingency violations that can't be mitigated, test will be rescheduled
 - 30 minutes notification shall be provided to allow PJM and the TO to adjust the system to ensure testing does not result in voltage limit violations
 - Notifies PJM of cancellation and/or rescheduling of testing

Reactive Capability Testing – Mitigating Actions

- Adjustments may need to be made to local voltage schedules in order to accommodate the scheduled testing
 - Adjustments will be considered and studied on a case by case basis
 - The impact of these deviations will be monitored by the TO and PJM
- PJM will discuss the changes with the appropriate TO and if the recommendation does not cause a violation of a defined limitation, the TO should implement the PJM request

Reactive Capability Testing – Mitigating Actions

- PJM will retain control of other reactive facilities (capacitors, LTCs, etc.)
- If internal plant or TO limits restrict the request, PJM dispatch will study the limitations and recommend changes to plant facilities if appropriate
 - If the recommended changes cannot be implemented due to equipment or facility limitations, other options will be considered, including test cancellation or rescheduling

Generator Reactive Testing

- Test Window

- Testing period:

- Maximum Lagging Test @ Maximum Real Power Output: Between 1200 and 1800 on weekdays from May 1st to September 30th
 - Maximum Leading Test @ Minimum Real Power Output: Between 2300 and 0700 EPT anytime of the year

Reactive Capability Testing – Test Conditions

- The following are steps that will be considered and agreed upon prior to allowing the scheduled generator reactive capability testing;
 - Each scheduled test will be studied and approved on a case by case basis
 - All required mitigation steps will be agreed to and coordinated with all concerned parties,
 - PJM RE
 - The responsible MOC (Unit Owner)
 - The appropriate TOs

Reactive Capability Testing – Test Conditions

- PJM will NOT allow any violations of its normal operating criteria;
 - No equipment may be operated above:
 - Its normal rating on an actual basis
 - Its Emergency rating on a post-contingency basis
 - In the event of a facility rating discrepancy between PJM and the TO that cannot be resolved, PJM will default to the most conservative limit

Reactive Capability Testing – Test Conditions

- PJM will NOT allow scheduled generator reactive capability testing to place the system in an unacceptable state
 - However, equipment failure could result in unplanned situational constraints that would require immediate remedial action
 - Standard mitigation steps will be taken to return the facilities in violation back to normal limits within fifteen minutes
 - The mitigation steps taken may not cause limit violations on any other company's equipment or facilities
 - PJM reserves the right to cancel the remainder of the testing

Reactive Capability Testing – The Day of the Test

- MOC (Unit Owner) will notify the PJM RE at least 3 hours before the start of the test to allow time for real-time studies to be completed
- An additional 30-minute notification should be provided to PJM Transmission and TO Operators to allow adjustments to system voltages prior to the test
 - TO Operators will coordinate any steps required to mitigate internal plant limitations with the Plant Operators or the MOC and PJM.
- If testing must be canceled or rescheduled, the MOC will inform PJM Reliability Engineer as soon as possible
 - The MOC will coordinate the implementation of their portion of the exit strategy with PJM, if required.

Generator Reactive Testing

- Exit Strategy
 - PJM will not allow reactive capability testing to place the system in an unacceptable state
 - Each test will be studied and approved on case by case basis
 - All mitigation steps are to be agreed upon and coordinated with all parties
 - No operations over pre-contingency normal ratings
 - No operations over post-contingency emergency ratings

Reactive Capability Testing – What if I need to Cancel?

- Test Cancellation
 - PJM dispatch and/or the impacted parties may cancel the generator reactive capability testing for the following reasons:
 - Internal planning issues
 - Emergency procedures
 - Inability to control actual or post-contingency voltage issues created by scheduled testing
 - Any operating issues created on TO equipment not monitored by PJM
 - Cancellation of the generator reactive capability test will be communicated to all impacted parties

Reactive Capability Testing – What if I need to Cancel?

- PJM will document all cancellations and terminations including the party responsible and the reason for the cancellation or termination



Generator Reactive Testing

- Results Reporting

- MOC/GO

- Submit all required testing results to PJM within 30 days
 - Test results submitted on “PJM Leading and/or Lagging Test Form R”

- PJM

- Provide feedback to Generation Owners on status of their test results
 - Also provide test results to appropriate TO
 - Conduct periodic audits of test results and provide results to OC and SOS

What Reactive Reserve Information is Reported?

- MOC's/GOs must also review and confirm their unit reactive capability data via eDART on a bi-annual basis
 - Pre-Summer Review: From April 1 through April 30
 - Pre-Winter Review: From October 1 through October 31
- PJM and the TOs will then verify accuracy of unit reactive capabilities modeled in their respective EMS systems

What Reactive Reserve Information is Reported?

- The MOC/GO must provide reactive capability curve information to PJM, the TO for the zone where the unit is located, and to any other TOs with eDART authority to receive automatic notification for the unit
 - *Continuous Unit Reactive Capability Curve* - data that provides the realistic usable reactive output that a generating unit is capable of delivering to the PJM Interconnection and sustaining over the steady state operating range of the unit
- For real-time changes, each MOC/GO should also notify PJM and the respective TOs via phone

What Reactive Reserve Information is Reported?

- Planned modifications (tap changer adjustment, GSU replacements, turbine modification, etc.) that impact generator reactive capability should be communicated to the impacted TOs and PJM as far in advance as possible but no later than the return of the unit from the outage

What Reactive Reserve Information is Reported?

- Whenever a unit's Automatic Voltage Regulation (AVR) or Power System Stabilizer (PSS) status is off (or is planned to be off) longer than 30 minutes, the MOC/GO must immediately enter a ticket via eDART
 - This requirement is exempted when the Unit starting up and shutting down
- For real-time changes, the GO/GOP must also notify the PJM Power Dispatcher (PD) and the respective TOs by phone
 - PJM and the TOs will change the status in their EMS systems

Reporting Reactive Capability Changes to PJM

For *Permanent* Changes

1. Each GO/GOP must continually provide accurate permanent capability curve changes to PJM via eDART ***as soon as the information is available***. The “New Default” field should be checked in eDART
2. Once the accuracy of the submitted reactive capability curve is verified, PJM will permanently update the PJM Unit Reactive Capability Curves in use by PJM Operating/Planning Studies and PJM EMS Network Applications programs

Reporting Reactive Capability Changes to PJM

For *Temporary* Changes

1. Whenever a PJM unit's reactive capability is limited or reduced (or is planned to be limited or reduced) for any reason, the GO/GOP must ***immediately enter a temporary ticket via eDART***. For real-time changes, the generator's owner/operator must also notify the PJM Power Dispatcher (PD) and respective LCC by phone
2. The PJM PD will receive the ticket and either temporarily update the unit's reactive capability curve in use by the PJM EMS Network Applications, or will temporarily set the unit's AVR status in use by the PJM EMS Network Applications to "OFF" for the specified time period

Reporting Reactive Capability Changes to PJM

For *Temporary* Changes (*con't*)

3. The GO/GOP must immediately modify the eDART ticket and notify the PJM PD and respective LCC by phone whenever the unit's normal reactive capability is (or is anticipated to be) restored
4. The PJM PD will either restore the unit's normal reactive capability curve in use by the PJM EMS Network Applications. The PJM PD will then close the unit reactive ticket

Questions?

PJM Client Management & Services

Telephone: (610) 666-8980

Toll Free Telephone: (866) 400-8980

Website: www.pjm.com



The Member Community is PJM's self-service portal for members to search for answers to their questions or to track and/or open cases with Client Management & Services

Resources & References



PJM. (2019). *PJM Manual 3: Transmission Operations (rev. 55)*. Retrieved from <http://pjm.com/~media/documents/manuals/m03.ashx>

PJM. (2019). *PJM Manual 12: Balancing Operations (rev. 39)*. Retrieved from <http://pjm.com/~media/documents/manuals/m12.ashx>

PJM. (2019). *PJM Manual 37: Reliability Coordination (rev 16)*. Retrieved from <http://www.pjm.com/~media/documents/manuals/m37.ashx>

EPRI. (2009). *EPRI Power System Dynamics Tutorial*. Palo Alto, California: EPRI.

Miller, R. & Malinowski, J. (1994). *Power System Operation*. (3rd ed.). Boston, MA. McGraw-Hill.

Clark, H. (2004). *Voltage and Reactive Power for Planning and Operation*.