

March 1, 2017

Kimberly D. Bose
Secretary
Federal Energy Regulatory Commission
888 First Street, N.E., Room 1A
Washington, D.C. 20426

Re: *PJM Interconnection, L.L.C.*, Docket No. ER17-_____
Queue Position AB2-057, Original Service Agreement No. 4648

Dear Secretary Bose:

Pursuant to section 205 of the Federal Power Act (“FPA”),¹ and part 35 of the regulations of the Federal Energy Regulatory Commission (“Commission”),² PJM Interconnection, L.L.C. (“PJM”) submits for filing an executed Wholesale Market Participation Agreement (“WMPA”) entered into among PJM, New Road Solar, LLC (“New Road”) as Wholesale Market Participant, and Public Service Electric and Gas Company (“PSE&G”) as Transmission Owner, executed on January 31, 2017 (“New Road WMPA”). PJM is submitting the New Road WMPA for filing because New Road intends to engage in wholesale sales in the PJM markets from a generating facility connected to PSE&G’s distribution facilities. PJM requests an effective date of January 31, 2017, for this WMPA, which is designated as Original Service Agreement No. 4648, and attached to this filing.³ The New Road WMPA will facilitate New Road’s intent to engage in jurisdictional wholesale transactions in the PJM markets, which will originate over PSE&G’s non-jurisdictional distribution facilities.

¹ 16 U.S.C. § 824d.

² 18 C.F.R. part 35.

³ A copy of the New Road WMPA is included as Attachment A. Because the New Road WMPA being electronically filed with this transmittal letter contains electronic signatures and not the original signatures of the parties, copies of the sheets containing the original signatures are included as Attachment B to this transmittal letter. Attachment B also contains initialed pages of the New Road WMPA that indicate the parties’ agreement to changes made to the New Road WMPA after it was executed.

I. Background

A. PJM's WMPA Process

On February 22, 2006, the Commission issued the GSG Order,⁴ which held that the interconnection of a generator to non-jurisdictional distribution facilities is not, in and of itself, action regulated by the FPA.⁵ The Commission further stated that the distribution facilities come under the Commission's jurisdiction once a wholesale transaction occurs on the system.⁶ This action would, therefore, render any subsequent interconnection to the relevant distribution facilities Commission-jurisdictional.⁷

PJM routinely receives requests from generation developers seeking to interconnect at a distribution level, in order to participate in sales to the PJM markets. Where the relevant facilities are non-jurisdictional (because there exists no previously interconnected generator engaging in wholesale transactions), and, in light of the GSG Order, PJM developed the WMPA as a contractual means to address these requests and provide to all affected parties a process to enable PJM to properly track and study this category of generator interconnection, as well as to facilitate the generator's participation in PJM's organized wholesale markets. The WMPA also serves to establish important revenue and (if necessary) operational metering requirements in order to give PJM visibility to pay the generator for output and for potential operational security requirements. In rare instances, a non-jurisdictional interconnection could impact the integrated transmission system. The WMPA process allows PJM to ensure that this contingency is studied and corrected, if necessary.

The Commission has previously accepted a number of WMPAs in earlier filings involving other participants. The instant filing is in the same form as the earlier submittals.⁸

⁴ See *PJM Interconnection, L.L.C.*, 114 FERC ¶ 61,191 (2006) ("GSG Order").

⁵ *Id.* at PP 14-16; see also *PJM Interconnection, L.L.C.*, 116 FERC ¶ 61,102, at P 19 (2006) (denying rehearing and clarification and noting the FPA denies the Commission jurisdiction "over facilities used in local distribution").

⁶ GSG Order at P 17.

⁷ See *id.* at PP 14, 17.

⁸ See, e.g., *PJM Interconnection, L.L.C.*, Letter Order, Docket No. ER16-2463-000 (Sept. 20, 2016); *PJM Interconnection, L.L.C.*, Letter Order, Docket No. ER16-2299-000 (Sept. 8, 2016); *PJM Interconnection, L.L.C.*, Letter Order, Docket No. ER16-1270-000 (Apr. 21, 2016); *PJM Interconnection, L.L.C.*, Letter Order, Docket No. ER16-1133-000 (Apr. 18, 2016); *PJM Interconnection, L.L.C.*, Letter Order, Docket No. ER16-1095-000 (Apr. 4, 2016).

B. Description of the WMPA

The New Road WMPA facilitates New Road's participation in PJM's organized wholesale markets via wholesale sales from its 10 MW New Road Solar Facility located in South Brunswick, New Jersey. *See* New Road WMPA, Specifications § 1.0. The New Road WMPA indicates that New Road will have Capacity Interconnection Rights in the amount of 3.8 MW commencing on June 1, 2020, and that nothing in the WMPA provides New Road with any rights with respect to the use of distribution facilities. *Id.*, Specifications § 2.1. It further provides for Capacity Interconnection Rights on an interim basis during the time period from January 31, 2017, to May 31, 2020, (the "interim time period") in an amount not to exceed 3.8 MW. *Id.* Any interim Capacity Interconnection Rights awarded during the interim time period will be dependent upon the completion and results of an interim deliverability study, and will terminate on May 31, 2020. *Id.* The Commission previously has accepted for filing WMPAs that grant similar interim Capacity Interconnection Rights.⁹ The WMPA also provides that to the extent any portion of the New Road Solar Facility is not a Capacity Resource with Capacity Interconnection Rights, such portion of the New Road Solar Facility is an Energy Resource, and that New Road will be permitted to sell energy into PJM's markets in an amount equal to the New Road Solar Facility's maximum output (10 MW), and that PJM reserves the right to limit injections in the event reliability would be affected by output greater than such quantity. *Id.*, Specifications § 2.0.¹⁰ Section 3.1 of the New Road WMPA establishes certain project-specific milestones, including the requirement that New Road enter into a two-party Interconnection Agreement with PSE&G in order to

⁹ *See, e.g., PJM Interconnection, L.L.C.*, Letter Order, Docket No. ER16-2463-000 (Sept. 20, 2016); *PJM Interconnection, L.L.C.*, Letter Order, Docket No. ER16-1678-000 (June 29, 2016); *PJM Interconnection, L.L.C.*, Letter Order, Docket No. ER16-416-000 (Dec. 28, 2015); *PJM Interconnection, L.L.C.*, Letter Order, Docket No. ER16-20-000 (Nov. 2, 2015); *PJM Interconnection, L.L.C.*, Letter Order, Docket No. ER15-2661-000 (Oct. 15, 2015); *PJM Interconnection, L.L.C.*, Letter Order, Docket No. ER15-2608-000 (Oct. 2, 2015). The Commission similarly has accepted Interconnection Service Agreements that grant similar interim Capacity Interconnection Rights. *See, e.g., PJM Interconnection, L.L.C.*, Letter Order, Docket No. ER16-1895-000 (July 25, 2016); *PJM Interconnection, L.L.C.*, Letter Order, Docket No. ER16-1078-000 (Apr. 26, 2016); *PJM Interconnection, L.L.C.*, Letter Order, Docket No. ER16-353-000 (Jan. 11, 2016).

¹⁰ *See PJM Interconnection, L.L.C.*, Letter Order, Docket No. ER16-1679-000 (June 29, 2016) (accepting WMPA granting similar Energy Resource rights); *PJM Interconnection, L.L.C.*, Letter Order, Docket No. ER16-1270-000 (Apr. 21, 2016) (same).

effectuate the WMPA.¹¹ There are no charges or security requirements associated with the New Road WMPA. New Road WMPA § 3.0.

II. This WMPA Establishes Reasonable Requirements to Enable Wholesale Transactions Subject to the Commission's Jurisdiction

The instant WMPA is filed pursuant to the Commission's jurisdiction under section 205 of the FPA and the Commission's independent jurisdictional authority over wholesale sales of electric energy and related products in PJM's markets. These transactions plainly constitute regulated wholesale transactions pursuant to section 201(b)(1) of the FPA.¹² Under the FPA, the Commission has broad jurisdiction to regulate the wholesale sale of electricity in interstate commerce.¹³ As noted above, the transactions will originate over facilities that are not Commission jurisdictional, namely the distribution facilities. In such circumstances, the Commission parses the transaction so as to apply its jurisdiction to only those aspects of the transaction that are Commission jurisdictional. For example, as discussed in Order No. 2003¹⁴ and other orders, the Commission applies this logic to determine jurisdiction over an interconnection on a facility used for both retail and wholesale transactions, by segregating the jurisdictional

¹¹ See *PJM Interconnection, L.L.C.*, Letter Order, Docket No. ER16-2299-000 (Sept. 8, 2016) (accepting WMPA with similar interconnection agreement requirement); *PJM Interconnection, L.L.C.*, Letter Order, Docket No. ER16-1727-000 (July 1, 2016) (same); *PJM Interconnection, L.L.C.*, Letter Order, Docket No. ER16-1834-000 (June 30, 2016) (same).

¹² Specifically, the FPA applies "to the transmission of electric energy in interstate commerce and to the sale of electric energy at wholesale in interstate commerce." 16 U.S.C. § 824(b)(1).

¹³ See 16 U.S.C. § 824d(d) ("Unless the Commission otherwise orders, no change shall be made by any public utility in any such rate, charge, classification, or service, or in any rule, regulation, or contract relating thereto, except after sixty days' notice to the Commission and to the public.").

¹⁴ *Standardization of Generator Interconnection Agreements and Procedures*, Order No. 2003, 2001-2005 FERC Stats. & Regs., Regs. Preambles ¶ 31,146 (2003), *order on reh'g*, Order No. 2003-A, 2001-2005 FERC Stats. & Regs., Regs. Preambles ¶ 31,160, *order on reh'g*, Order No. 2003-B, 2001-2005 FERC Stats. & Regs., Regs. Preambles ¶ 31,171 (2004), *order on reh'g*, Order No. 2003-C, 2001-2005 FERC Stats. & Regs., Regs. Preambles ¶ 31,190 (2005), *aff'd sub nom. Nat'l Ass'n of Regulatory Utils. Comm'rs v. FERC*, 475 F.3d 1277 (D.C. Cir. 2007).

transaction from the retail sales.¹⁵ The Commission noted: “[W]here the ‘distribution’ facilities have a dual use, *i.e.*, the facilities are used for both wholesale sales and retail sales, the Final Rule applies to interconnections to these facilities *only for the purpose of making sales of electric energy for resale in interstate commerce.*”¹⁶ The Commission bifurcates the use of the facility and applies its jurisdiction only to the applicable transaction, the wholesale sale. Here, the generator’s use of, and taking of service over, the distribution facilities does not diminish the Commission’s independent jurisdiction to regulate the generator’s sale of energy and related products in PJM’s organized wholesale markets.

This logic is consistently applied in other areas of Commission jurisdiction as well. For example, the Commission applied similar reasoning when it determined it has jurisdiction to require transmission service over non-jurisdictional local distribution facilities in *Tex-La Electric Cooperative of Texas, Inc.*¹⁷ The Commission noted that it retained authority to order transmission service pursuant to section 211 of the FPA¹⁸ regardless of any local distribution function of the facilities involved and “transmission services may encompass the use of facilities that in other contexts would be classified as distribution facilities.”¹⁹ Similarly, in *Laguna Irrigation District*, the Commission noted that wholesale customers should be allowed the protection of section 210 of the FPA²⁰ based merely on the label attached to the facilities to which they interconnect.²¹

¹⁵ See Order No. 2003 at PP 803-05; see also *PJM Interconnection*, 116 FERC ¶ 61,102, at P 22 (“Because no wholesale transaction is being conducted on ComEd’s distribution facilities, we find there is no Commission-jurisdictional use of the facilities” Hence, a wholesale transaction would be a jurisdictional use.); *Detroit Edison Co. v. FERC*, 334 F.3d 48, 51 (D.C. Cir. 2003) (explaining that the Commission has jurisdiction “over all wholesale service,” including wholesale transactions that occur over “local distribution” facilities).

¹⁶ Order No. 2003 at P 804; accord Order No. 2003-C at P 53.

¹⁷ *Tex-La Elec. Coop. of Tex., Inc.*, 67 FERC ¶ 61,019, at 61,055-56, *final order*, 69 FERC ¶ 61,269 (1994); see also *Laguna Irrigation Dist.*, 95 FERC ¶ 61,305, at 62,038-39 (2001), *aff’d sub nom. Pac. Gas & Elec. Co. v. FERC*, 44 Fed. Appx. 170 (9th Cir. 2002).

¹⁸ 16 U.S.C. § 824j.

¹⁹ *Tex-La Elec. Coop.*, 67 FERC ¶ 61,019, at 61,055-56 n.36 (emphasis added).

²⁰ 16 U.S.C. § 824i.

²¹ *Laguna Irrigation Dist.*, 95 FERC ¶ 61,305, at 62,038-39.

Accordingly, since the WMPA addresses the terms and conditions necessary for the generator to make wholesale sales into the PJM markets, PJM applies the same reasoning as detailed above and believes that an agreement enabling such sales (the WMPA) similarly falls within the Commission's jurisdiction.

Should the Commission disagree and decide not to exercise its jurisdiction over the WMPA, PJM will, nonetheless, require execution of the WMPA by similarly-situated generators and transmission owners as a matter of contract. The matters addressed by the WMPA are essential to preserve the continued integrity of PJM's functions as a grid operator and market administrator and, as such, are properly deemed reasonable conditions of entry, like other Regional Transmission Organization membership requirements, for a generator electing to participate in PJM's voluntary markets.

III. The WMPA Applies to Wholesale Sales Only

PJM submits the WMPA for filing because the WMPA is a form of agreement not presently contained in either the PJM Open Access Transmission Tariff ("PJM Tariff") or the Amended and Restated Operating Agreement of PJM Interconnection, L.L.C. ("PJM Operating Agreement"). The WMPA applies only to wholesale transactions and is not intended to govern the actual physical interconnection of a generating facility to the distribution system. Therefore, it is immaterial whether the WMPA concerns a new interconnection to a distribution system or a pre-existing interconnection on a distribution system where the preexisting generator subsequently elects to participate in the PJM markets. The WMPA will be initiated for the purpose of facilitating the wholesale sale and not the interconnection. To date, generator market participants connecting to the distribution system have been receptive to the use of the WMPA as a means to facilitate future sales into the PJM markets and to support the state interconnection processes as well. Further, the WMPA allows a vehicle for PJM to examine the potential reliability impacts the interconnection may have on the grid.

As the GSG Order directs,²² interconnection to the distribution system is not Commission-jurisdictional until wholesale sales begin on the system. Hence, the PJM Tariff would not apply to govern the terms and conditions of the physical interconnection, including the attachment of facilities and terms of use and charges for distribution service needed to afford the generator access to the PJM Transmission System. Again, PJM's interest is to ensure sufficient visibility and, where necessary, control over generation that is participating as a Market Seller²³ under the PJM Operating Agreement.²⁴

²² See GSG Order at P 14.

²³ See PJM Operating Agreement § 1 (definition of "Market Seller").

²⁴ See *id.*, Schedule 1.

IV. The WMPA Differs from the ISA in Numerous Important Aspects

The WMPA is designed to have a similar format to the PJM Interconnection Service Agreement (“ISA”) in order to provide a manageable and familiar document for the participants. Unlike the ISA, however, the WMPA does not address matters involving the actual physical interconnection of the generator to the distribution system or any terms, conditions or charges related to any service provided by the distribution system to the generator. The WMPA contains many provisions also typically found in an ISA that govern the relationship between the generator and PJM. These provisions establish reasonable and necessary standards and qualifications, such as revenue quality metering, both to enable the generator to participate as a Market Seller in PJM’s market and to allow PJM’s system operations the necessary visibility to the generator for reliability purposes. However, the WMPA is not an ISA and is not intended as a substitute for an interconnection agreement between the owners of the interconnecting physical facilities.

More specifically, the WMPA differs from the ISA in several key respects. First, the WMPA does not contain any reference to attachment facilities necessary for the interconnection. The WMPA also does not reference network upgrades for the interconnection to the distribution facility. In limited circumstances, the Feasibility Study and/or the System Impact Study may conclude that there is a significant impact to other jurisdictional interconnections that are located on the nearest transmission system, or a possible impact to facilities that are located on a nearby Commission-jurisdictional distribution facility. If this were the case, the interconnecting generator could be required to fund network upgrades on the corresponding jurisdictional systems only. In the event additional upgrades were needed, the WMPA contains proposed language concerning “Responsibility for Network or Local Upgrades” in Article 3 of the WMPA. At the discretion of the parties, they may simply mark this section as “not applicable” or delete the section from the WMPA in its entirety when this contract language is inapplicable (as it will be in the majority of cases).

Generally, the WMPA does not contain security requirements (with the limited exception as explained above), or construction requirements. The WMPA also makes no reference to reactive power requirements, and construction of transmission owner interconnection facilities. These are the key components of the ISA that are not included in the WMPA because these ISA components are not relevant to the wholesale transactions.

V. Waiver and Effective Date

PJM requests that the Commission grant any and all waivers of the Commission’s rules and regulations that are necessary for acceptance of this filing and the enclosed WMPA. Additionally, PJM requests a waiver of the Commission’s sixty-day prior notice requirement to allow an effective date of January 31, 2017, for the New Road WMPA, as set forth in section 1.1 thereof. Waiver is appropriate because this effective date is

consistent with the intent of the parties, as set forth in section 1.1 of the New Road WMPA.²⁵ Furthermore, the requested waiver is limited in scope and will result in no harm to third parties. Moreover, the Commission has allowed waivers of its prior notice requirements when supported by the facts that the filing is uncontested and does not change rates,²⁶ and should do the same here. PJM also notes that, as there are no charges or security requirements associated with the New Road WMPA or monies collected pursuant to this agreement, *see* New Road WMPA § 3.0, time-value refunds are not required.²⁷ The Commission has granted similar waivers for other filings involving WMPAs.²⁸

VI. Documents Enclosed

PJM encloses the following:

1. This Transmittal Letter;
2. Attachment A: Original Service Agreement No. 4648; and
3. Attachment B: Copies of Sheets Containing Original Signatures.

VII. Service

Copies of this filing have been served upon the parties, New Road and PSE&G, as well as on the affected state utility commission(s) within the PJM region.

²⁵ If the Commission does not allow a January 31, 2017 effective date, PJM requests that the Commission grant the earliest effective date possible, and no later than March 2, 2017, one day after this filing. The Commission has allowed jurisdictional agreements to become effective one day after filing. *See Palo Duro Wind Interconnection Servs., LLC*, 149 FERC ¶ 61,205, at P 9 (2014); *Midcontinent Indep. Sys. Operator, Inc.*, 145 FERC ¶ 61,032, at P 49 (2013).

²⁶ *See ISO New England, Inc.*, 116 FERC ¶ 61,308, at P 8 (2006); *see also Cent. Hudson Gas & Elec. Corp.*, 60 FERC ¶ 61,106, at 61,338 (1992) (waiving prior notice requirement when uncontested filings do not change rates).

²⁷ *See ITC Midwest LLC*, 138 FERC ¶ 61,105, at P 14 (2012); *see also Lake Benton Power Partners LLC*, 146 FERC ¶ 61,095, at P 7 (2014).

²⁸ *See supra* note 8.

VIII. Correspondence and Communications

All notices, communications or correspondence addressed to PJM regarding this matter should be directed to, and PJM requests that the Secretary include on the Commission's official service list, the following:²⁹

Craig Glazer
Vice President – Federal Government
Policy
PJM Interconnection, L.L.C.
1200 G Street, N.W., Suite 600
Washington, DC 20005
(202) 423-4743 (phone)
(202) 393-7741 (fax)
Craig.Glazer@pjm.com

Carrie L. Bumgarner
Sidney L. Fowler
Wright & Talisman, P.C.
1200 G Street, N.W., Suite 600
Washington, D.C. 20005
(202) 393-1200 (phone)
(202) 393-1240 (fax)
bumgarner@wrightlaw.com
fowler@wrightlaw.com

Steven R. Pincus
Associate General Counsel
PJM Interconnection, L.L.C.
2750 Monroe Boulevard
Audubon, PA 19403
(610) 666-4370 (phone)
(610) 666-4281 (fax)
steven.pincus@pjm.com

²⁹ To the extent necessary, PJM requests waiver of Rule 203(b)(3) of the Commission's Rules of Practice and Procedure, 18 C.F.R. § 385.203(b)(3), to permit all of the persons listed to be placed on the official service list for this proceeding.

IX. Conclusion

For the foregoing reasons, PJM requests that the Commission accept the New Road WMPA with an effective date of January 31, 2017.

Respectfully submitted,

/s/ Sidney L. Fowler

Carrie L. Bumgarner
Sidney L. Fowler
Wright & Talisman, P.C.
1200 G Street, N.W., Suite 600
Washington, D.C. 20005
(202) 393-1200 (phone)
(202) 393-1240 (fax)
bumgarner@wrightlaw.com
fowler@wrightlaw.com

Counsel for
PJM Interconnection, L.L.C.

Craig Glazer
Vice President – Federal Government
Policy
PJM Interconnection, L.L.C.
1200 G Street, N.W., Suite 600
Washington, DC 20005
(202) 423-4743 (phone)
(202) 393-7741 (fax)
Craig.Glazer@pjm.com

Steven R. Pincus
Associate General Counsel
PJM Interconnection, L.L.C.
2750 Monroe Boulevard
Audubon, PA 19403
(610) 666-4370 (phone)
(610) 666-4281 (fax)
steven.pincus@pjm.com

Attachment A

**New Road WMPA,
Original Service Agreement No. 4648**

(PJM Queue #AB2-057)

WHOLESALE MARKET PARTICIPATION AGREEMENT
Among
PJM INTERCONNECTION, L.L.C.
And
NEW ROAD SOLAR, LLC
And
PUBLIC SERVICE ELECTRIC AND GAS COMPANY

WHOLESALE MARKET PARTICIPATION AGREEMENT

**By and Among
PJM Interconnection, L.L.C.**

And

New Road Solar, LLC

And

**Public Service Electric and Gas Company
(PJM Queue Position #AB2-057)**

This Wholesale Market Participation Agreement (“WMPA”) including the Specifications, and Schedules attached hereto and incorporated herein, is entered into in order to effectuate sales of energy and/or capacity into PJM’s wholesale markets, by and between PJM Interconnection, L.L.C., the Regional Transmission Organization for the PJM Region (“Transmission Provider”), New Road Solar, LLC (“Wholesale Market Participant”) and Public Service Electric and Gas Company (“Transmission Owner” or “PSE&G”) (referred to individually as “Party” or collectively as “the Parties”).

WITNESSETH

WHEREAS, Wholesale Market Participant is developing generation that it intends to use to engage in Wholesale Transactions in PJM’s markets and desires to maintain its proposed generation in the queue that PJM studies for potential reliability impacts to the Transmission System;

WHEREAS, Wholesale Market Participant is seeking to interconnect at a local distribution or sub-transmission facility, which at this time is not subject to FERC jurisdiction; and

WHEREAS, Wholesale Market Participant and Transmission Owner or its affiliate must enter into a separate two-party interconnection agreement (“Interconnection Agreement”) in order to address issues of physical interconnection and local charges that may be presented by the interconnection of Wholesale Market Participant’s generation to the distribution facility.

NOW, THEREFORE, in consideration of the mutual covenants herein contained, together with other good and valuable consideration, the receipt and sufficiency is hereby mutually acknowledged by Transmission Provider, Transmission Owner and Wholesale Market Participant and the parties agree to assume all of the rights and obligations consistent with the rights and obligations relating to Network Upgrades, Local Upgrades and metering requirements set forth in Part VI of the Tariff, as of the effective date of this WMPA, required for Wholesale Market Participant to make Wholesale Transactions in PJM’s markets. The Parties mutually covenant and agree as follows:

Article 1 – DEFINITIONS and OTHER DOCUMENTS

- 1.0 Defined Terms.** All capitalized terms herein shall have the meanings as set forth in the definitions of such terms as stated in Part I, Article 1 or Part VI of the PJM Open Access Transmission Tariff (“Tariff”), except Wholesale Market Participant which shall be defined in this WMPA as a participant in a Wholesale Transaction.
- 1.1 Effective Date.** This WMPA shall become effective on the date it is executed by all Parties, or, if this WMPA is filed with FERC unexecuted, upon the date specified by FERC. This WMPA shall terminate on such date as mutually agreed upon by the parties, unless earlier terminated consistent with Section 1 in Attachment O, Appendix 2, Part VI of the Tariff.
- 1.2 Assumption of Tariff Obligations.** Wholesale Market Participant agrees to abide by all rules and procedures pertaining to generation and transmission in the PJM Region, including but not limited to the rules and procedures concerning the dispatch of generation or scheduling transmission set forth in the Tariff, the Operating Agreement and the PJM Manuals.
- 1.3 Incorporation Of Other Documents.** All portions of the Tariff and the Operating Agreement pertinent to the subject matter of this WMPA and not otherwise made a part hereof are hereby incorporated herein and made a part hereof.

Article 2 - NOTICES and MISCELLANEOUS

- 2.0 Notices.** Any notice, demand or request required or permitted to be given by any Party to another and any instrument required or permitted to be tendered or delivered by any Party in writing to another may be so given, tendered or delivered by recognized national courier or by depositing the same with the United States Postal Service, with postage prepaid for delivery by certified or registered mail addressed to the Party, or by personal delivery to the Party, at the address specified below. Such notices, if agreed to by the Parties, may be made via electronic means, with e-mail confirmation of delivery.

Transmission Provider:

PJM Interconnection, L.L.C.
2750 Monroe Blvd.
Audubon, PA 19403-2497

Wholesale Market Participant:
New Road Solar, LLC
20A South Beers Street
Holmdel, NJ 07733

Transmission Owner:

Public Service Electric and Gas Company
80 Park Plaza
Newark, NJ 07101
Attn: Sheree Kelly

Either Party may change its address or designated representative for notice by notice to the other Parties in the manner provided for above.

- 2.1 Construction With Other Parts Of The Tariff.** This WMPA shall not be construed as an application for service under Part II or Part III of the Tariff.
- 2.2 Warranty for Facilities Study.** In analyzing and preparing the System Impact Study, and in designing and constructing the Local Upgrades and/or Network Upgrades described in Part II of the Tariff and in the Specifications attached to this WMPA, Transmission Provider, the Transmission Owner(s), and any other subcontractors employed by Transmission Provider have had to, and shall have to, rely on information provided by Wholesale Market Participant and possibly by third parties and may not have control over the accuracy of such information. Accordingly, NEITHER TRANSMISSION PROVIDER, THE TRANSMISSION OWNER(s), NOR ANY OTHER SUBCONTRACTORS EMPLOYED BY TRANSMISSION PROVIDER OR TRANSMISSION OWNER MAKES ANY WARRANTIES, EXPRESS OR IMPLIED, WHETHER ARISING BY OPERATION OF LAW, COURSE OF PERFORMANCE OR DEALING, CUSTOM, USAGE IN THE TRADE OR PROFESSION, OR OTHERWISE, INCLUDING WITHOUT LIMITATION IMPLIED WARRANTIES OF MERCHANTABILITY AND FITNESS FOR A PARTICULAR PURPOSE, WITH REGARD TO THE ACCURACY, CONTENT, OR CONCLUSIONS OF THE FACILITIES STUDY OR THE SYSTEM IMPACT STUDY IF A FACILITIES STUDY WAS NOT REQUIRED OR OF THE LOCAL UPGRADES AND/OR THE NETWORK UPGRADES, PROVIDED, HOWEVER, that Transmission Provider warrants that the Transmission Owner Facilities described in the Specifications will be designed and constructed (to the extent that Transmission Owner is responsible for design and construction thereof) and operated in accordance with Good Utility Practice, as such term is defined in the Operating Agreement. Wholesale Market Participant acknowledges that it has not relied on any representations or warranties not specifically set forth herein and that no such representations or warranties have formed the basis of its bargain hereunder.
- 2.3 Waiver.** No waiver by any party of one or more defaults by the other in performance of any of the provisions of this WMPA shall operate or be construed as a waiver of any other or further default or defaults, whether of a like or different character.
- 2.4 Amendment.** This WMPA or any part thereof, may not be amended, modified, or waived other than by a written document signed by all parties hereto.
- 2.5 Addendum of Wholesale Market Participant's Agreement to Conform with IRS Safe Harbor Provisions for Non-Taxable Status.** To the extent required, in accordance with Section 24.1 in Attachment O, Appendix 2 in Part VI of the Tariff, Schedule E to

this WMPA shall set forth the Wholesale Market Participant's agreement to conform with the IRS safe harbor provisions for non-taxable status.

2.6 Assignment

2.6.1 Assignment with Prior Consent:

If the Interconnection Agreement between the Wholesale Market Participant and the Transmission Owner, as referenced in section 3.1.4 herein, provides that such Interconnection Agreement may be assigned, and such Interconnection Agreement was assigned, then, except as provided in Section 2.6.2 of this WMPA, no Party shall assign its rights or delegate its duties under this WMPA without the prior written consent of the other Parties, which consent shall not be unreasonably withheld, conditioned, or delayed; and any such assignment or delegation made without such prior written consent shall be null and void. A Party may make an assignment in connection with the sale, merger, or transfer of all of its properties, including the Participant Facility, which it owns, so long as the assignee in such a sale, merger, or transfer assumes in writing all rights, duties and obligations arising under this WMPA. In addition, the Transmission Owner shall be entitled, subject to applicable laws and regulations, to assign the WMPA to an Affiliate or successor that owns and operates all or a substantial portion of the Transmission Owner's transmission facilities.

2.6.2 Assignment without Prior Consent

2.6.2.1 Assignment to Owners:

If the Interconnection Agreement between the Wholesale Market Participant and the Transmission Owner, as referenced in section 3.1.4 herein, provides that such Interconnection Agreement may be assigned, and such Interconnection Agreement was assigned, then the Wholesale Market Participant may assign its rights or delegate its duties under this WMPA without the Transmission Owner's or Transmission Provider's prior consent to any Affiliate or person that purchases or otherwise acquires, directly or indirectly, all of the Participant Facility, provided that prior to the effective date of any such assignment: (1) the assignee shall demonstrate that, as of the effective date of the assignment, the assignee has the technical and operational competence to comply with the requirements of this WMPA; and (2) in writing to the Transmission Owner and Transmission Provider, assignee assumes all rights, duties, and obligations of Wholesale Market Participant arising under this WMPA. However, any assignment described herein shall not relieve or discharge the Wholesale Market Participant from any of its obligations hereunder absent the written consent of the Transmission Provider, such consent not to be unreasonably withheld, conditioned or delayed.

2.6.2.2 Assignment to Lenders:

If the Interconnection Agreement between the Wholesale Market Participant and the Transmission Owner, as referenced in section 3.1.4 herein, provides that such

Interconnection Agreement may be assigned to any Project Finance Entity(ies), and such Interconnection Agreement was assigned, then the Wholesale Market Participant may, without consent of the Transmission Provider or the Transmission Owner, assign this WMPA to such Project Finance Entity(ies), provided that such assignment does not alter or diminish Wholesale Market Participant's duties and obligations under this WMPA. If Wholesale Market Participant provides the Transmission Owner and Transmission Provider with notice of an assignment to such Project Finance Entity(ies) and identifies such Project Finance Entity(ies) as a contact for notice of Breach pursuant to section 1.1 herein, the Transmission Provider or Transmission Owner shall provide notice and reasonable opportunity for such Project Finance Entity(ies) to cure any Breach under this WMPA in accordance with this WMPA. Transmission Provider or Transmission Owner shall, if requested by such Project Finance Entity(ies), provide such customary and reasonable documents, including consents to assignment, as may be reasonably requested with respect to the assignment and status of this WMPA, provided that such documents do not alter or diminish the rights of the Transmission Provider or Transmission Owner under this WMPA, except with respect to providing notice of Breach pursuant to section 1.1 of this WMPA, to such Project Finance Entity(ies). Upon presentation of the Transmission Provider and/or Transmission Owner's invoice therefor, Wholesale Market Participant shall pay the Transmission Provider and/or the Transmission Owner's reasonable documented cost of providing such documents and certificates as requested by such Project Finance Entity(ies). Any assignment described herein shall not relieve or discharge the Wholesale Market Participant from any of its obligations hereunder absent the written consent of the Transmission Owner and Transmission Provider.

2.6.3 Successors and Assigns:

This WMPA and all of its provisions are binding upon, and inure to the benefit of, the Parties and their respective successors and permitted assigns.

ARTICLE 3 – Responsibility for Network or Local Upgrades

- 3.0 Security for Network or Local Upgrades.** Consistent with Section 212.4 in Part VI of the Tariff, Wholesale Market Participant, on or before the effective date of this WMPA, shall provide the Transmission Provider (for the benefit of the Transmission Owner) with a letter of credit from an agreed provider or other form of security reasonably acceptable to the Transmission Provider and that names the Transmission Provider as beneficiary (“Security”) in the amount of \$0. This amount represents the sum of the estimated Costs, determined consistent with Section 217 in Part VI of the Tariff, of (i) the Local Upgrades and/or Network Upgrades described in Section 3.4 of this WMPA less any Costs already paid by the Wholesale Market Participant. Should Wholesale Market Participant fail to provide Security in the amount or form required in the first sentence of this Section, this WMPA shall be terminated. Wholesale Market Participant acknowledges that its ultimate cost responsibility consistent with Section 217 in Part VI of the Tariff will be based upon the actual Costs of the facilities described in the Specifications to this WMPA, whether greater or lesser than the amount of the Security provided under this Section.
- 3.1 Project Specific Milestones.** During the term of this WMPA, Wholesale Market Participant shall ensure that it meets each of the following milestones:
- 3.1.1 Substantial Site work completed.** On or before August 31, 2017 Wholesale Market Participant must demonstrate completion of at least 20% of project site construction.
 - 3.1.2 Commercial Operation.** (i) On or before March 30, 2018, Wholesale Market Participant must demonstrate commercial operation of all generating units; (ii) On or before October 27, 2017, Wholesale Market Participant must demonstrate commercial sale or use of energy and, if applicable obtain capacity qualification consistent with the requirements of the Reliability Assurance Agreement Among Load Serving Entities in the PJM Region.
 - 3.1.3 Documentation.** Within one (1) month following commercial operation of generating unit(s), Wholesale Market Participant must provide certified documentation demonstrating that “as-built” Participant Facility are consistent with applicable PJM studies and agreements. Wholesale Market Participant must also provide PJM with “as-built” electrical modeling data or confirm that previously submitted data remains valid.
 - 3.1.4 Interconnection Agreement.** On or before April 15, 2017, Wholesale Market Participant must enter into an Interconnection Agreement with the Transmission Owner in order to effectuate the WMPA.

Wholesale Market Participant shall demonstrate the occurrence of each of the foregoing milestones to Transmission Provider's reasonable satisfaction. Transmission Provider may reasonably extend any such milestone dates, in the event of delays that Wholesale Market Participant (i) did not cause and (ii) could not have remedied through the exercise of due diligence.

If (i) the Wholesale Market Participant suspends work pursuant to a suspension provision contained in an interconnection and/or construction agreement with the Transmission Owner or (ii) the Transmission Owner extends the date by which Wholesale Market Participant must enter into an interconnection agreement relative to this WMPA, and (iii) the Wholesale Market Participant has not made a wholesale sale under this WMPA, the Wholesale Market Participant may suspend this WMPA by notifying the Transmission Provider and the Transmission Owner in writing that it wishes to suspend this WMPA, with the condition that, notwithstanding such suspension, the Transmission System shall be left in a safe and reliable condition in accordance with Good Utility Practice and Transmission Provider's safety and reliability criteria. Wholesale Market Participant's notice of suspension shall include an estimated duration of the suspension period and other information related to the suspension. Pursuant to this section 3.1, Wholesale Market Participant may request one or more suspensions of work under this WMPA for a cumulative period of up to a maximum of three years. If, however, the suspension will result in a Material Modification as defined in Part I, Section 1.18A.02 of the Tariff, then such suspension period shall be no greater than one (1) year. If the Wholesale Market Participant suspends this WMPA pursuant to this Section 3.1 and has not provided written notice that it will exit such suspension on or before the expiration of the suspension period described herein, this WMPA shall be deemed terminated as of the end of such suspension period. The suspension time shall begin on the date the suspension is requested or on the date of the Wholesale Market Participant's written notice of suspension to Transmission Provider, if no effective date was specified. All milestone dates stated in this Section 3.1 shall be deemed to be extended coextensively with any suspension period permitted pursuant to this provision.

IN WITNESS WHEREOF, Transmission Provider, Wholesale Market Participant and Transmission Owner have caused this WMPA to be executed by their respective authorized officials. By each individual signing below, each represents to the other that they are duly authorized to sign on behalf of their company and have the actual and/or apparent authority to bind the respective company to this WMPA.

(PJM Queue Position #AB2-057)

Transmission Provider: **PJM Interconnection, L.L.C.**

By: David M. Egan Manager, Interconnection Projects 1/31/17
 Name Title Date

Printed name of signer: David M. Egan

Wholesale Market Participant: **New Road Solar, LLC**

By: Justin Sallusto COO 12/22/16
 Name Title Date

Printed name of signer: Justin Sallusto

Transmission Owner: **Public Service Electric and Gas Company**

By: Jodi Moskowitz Sr. Director – TD & S 1/26/17
 Name Title Date

Printed name of signer: Jodi Moskowitz

**SPECIFICATIONS FOR
WHOLESALE MARKET PARTICIPATION AGREEMENT**

**By and Among
PJM INTERCONNECTION, L.L.C.**

**And
New Road Solar, LLC**

**And
Public Service Electric and Gas Company
(PJM Queue Position # AB2-057)**

1.0 Description of generating unit(s) (the “Participant Facility”) to be used for the provision of wholesale sales into the PJM markets:

a. Name of Participant Facility:

New Road Solar

b. Location of Participant Facility:

New Road, South Brunswick, NJ

c. Size in megawatts of Participant Facility:

Maximum Facility Output of 10 MW

d. Description of the equipment configuration:

Photovoltaic Solar Panels and Inverters

2.0 Rights for Generation Wholesale Market Participant

2.1 Capacity Interconnection Rights:

Consistent with the applicable terms of the Tariff, the Wholesale Market Participant shall have Capacity Interconnection Rights at the point(s) of interconnection specified in Schedule A of this Wholesale Market Participant Agreement in the amount of 3.8 MW; provided however, nothing in this WMPA provides any rights with regard to the use of distribution facilities.

Pursuant to and subject to the applicable terms of the Tariff, the Interconnection Customer shall have Capacity Interconnection Rights at the Point(s) of Interconnection specified in this Wholesale Market Participation Agreement in the amount of 3.8 MW commencing June 1, 2020. During the time period from the effective date of this WMPA until May 31, 2020 (the “interim time period”), the Interconnection Customer may be awarded interim Capacity Interconnection Rights in an amount not to exceed 3.8 MW. The availability and amount of such

interim Capacity Interconnection Rights shall be dependent upon completion and results of an interim deliverability study. Any interim Capacity Interconnection Rights awarded during the interim time period shall terminate on May 31, 2020.

To the extent that any portion of the Participant Facility described in Section 1.0 is not a Capacity Resource with Capacity Interconnection Rights, such portion of the Participant Facility shall be an Energy Resource. Pursuant to this WMPA, the Wholesale Market Participant may sell energy into PJM's markets in an amount equal to the Participant Facility's Maximum Facility Output indicated in Section 1.0c of the Specifications for this WMPA. PJM reserves the right to limit injections in the event reliability would be affected by output greater than such quantity.

3.0 Ownership and Location of Metering Equipment. The metering equipment to be constructed, the capability of the metering equipment to be constructed, and the ownership thereof, as required for the Wholesale Transactions shall be identified on the attached Schedule B to this WMPA, and provided consistent with the PJM manuals.

SCHEDULES:

- **SCHEDULE A - SINGLE-LINE DIAGRAM (Showing point of interconnection)**
- **SCHEDULE B - LIST OF METERING EQUIPMENT**
- **SCHEDULE C - LIST OF LOCAL/NETWORK UPGRADES**
- **SCHEDULE D - APPLICABLE TECHNICAL REQUIREMENTS AND STANDARDS**
- **SCHEDULE E - WHOLESALE MARKET PARTICIPANT AGREEMENT TO CONFORM WITH IRS SAFE HARBOR PROVISIONS FOR NON-TAXABLE STATUS**
- **SCHEDULE F – SCHEDULE OF NON-STANDARD TERMS & CONDITIONS**

SCHEDULE A

SINGLE-LINE DIAGRAM

PSE&G

Solar Production Sites – 26kV POI Brunswick P238

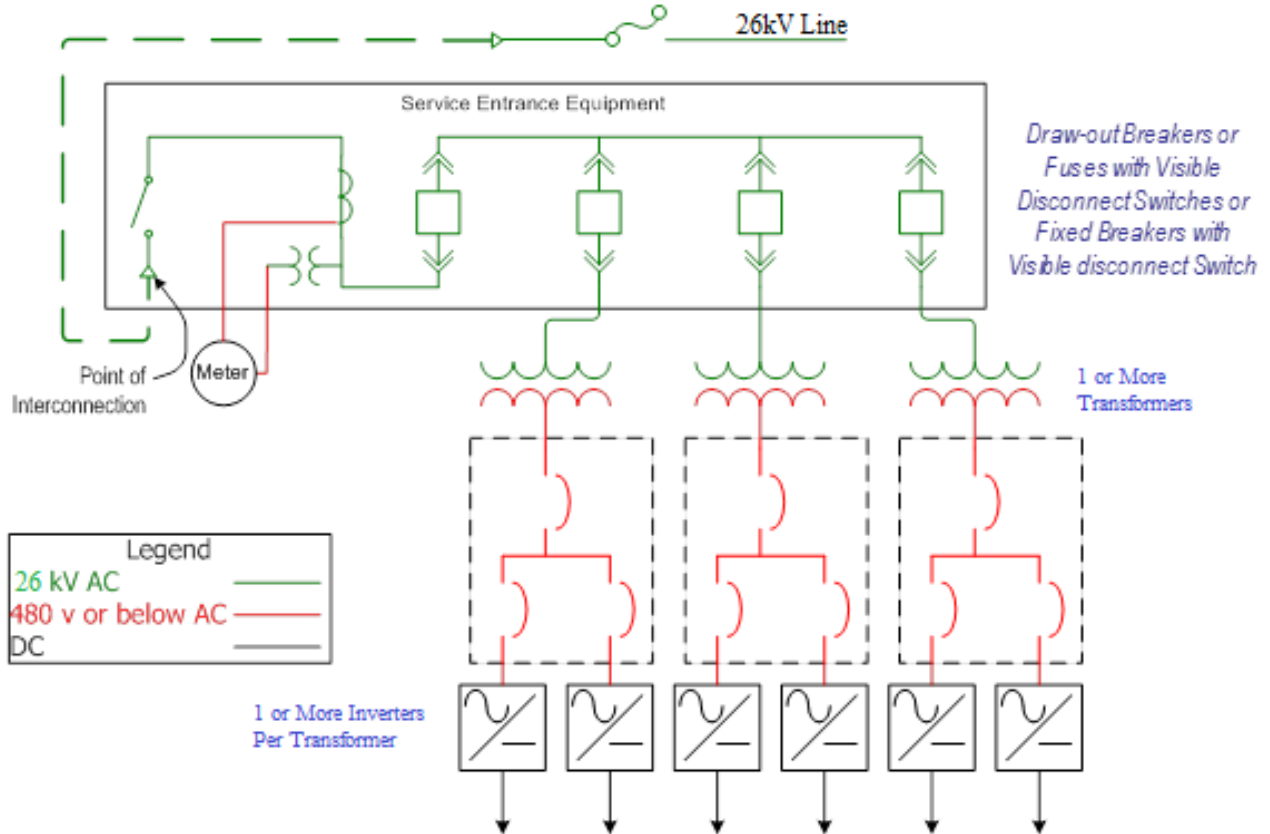

SCHEDULE B

LIST OF METERING EQUIPMENT

The Wholesale Market Participant will be required to install telemetry and communication equipment to provide real-time telemetry and revenue (settlements) data to PJM as well as having the ability to receive and respond to PJM operational command and control signals. The Wholesale Market Participant may elect to have the Transmission Owner install, own, operate, test and maintain the metering equipment at the Wholesale Market Participant's expense. The requirements for this equipment are listed in Appendix 2, Section 8 of Attachment O to the Tariff, as well as PJM Manuals 01 and 14D.

<http://www.pjm.com/~media/documents/manuals/m01.ashx>

<http://www.pjm.com/~media/documents/manuals/m14d.ashx>

SCHEDULE C

LIST OF LOCAL/NETWORK UPGRADES

Not Required.

SCHEDULE D

APPLICABLE TECHNICAL REQUIREMENTS AND STANDARDS

Not Required.

SCHEDULE E

**WHOLESALE MARKET PARTICIPANT'S AGREEMENT TO CONFORM WITH IRS
SAFE HARBOR PROVISIONS FOR NON-TAXABLE STATUS**

Not Required.

SCHEDULE F

SCHEDULE OF NON-STANDARD TERMS & CONDITIONS

Not Required.

Attachment B

Copies of Sheets Containing Original Signatures to the New Road WMPA

IN WITNESS WHEREOF, Transmission Provider, Wholesale Market Participant and Transmission Owner have caused this WMPA to be executed by their respective authorized officials. By each individual signing below, each represents to the other that they are duly authorized to sign on behalf of their company and have the actual and/or apparent authority to bind the respective company to this WMPA.

(PJM Queue Position #AB2-057)

Transmission Provider: **PJM Interconnection, L.L.C.**

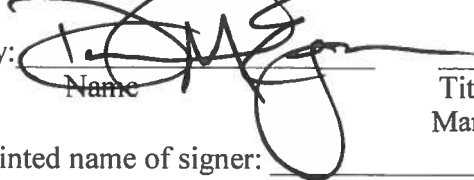
By:  1/31/17
Name Title Date
Manager, Interconnection Projects
Printed name of signer: David M. Egan

Wholesale Market Participant: **New Road Solar, LLC**

By:  CCO 12/22/15
Name Title Date
Printed name of signer: Justin Sallusto

Transmission Owner: **Public Service Electric and Gas Company**

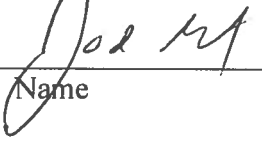
By:  Sr Director - TD&S 1/26/17
Name Title Date
Printed name of signer: Jodi Moskowitz

ARTICLE 3 – Responsibility for Network or Local Upgrades

- 3.0 Security for Network or Local Upgrades.** Consistent with Section 212.4 in Part VI of the Tariff, Wholesale Market Participant, on or before the effective date of this WMPA, shall provide the Transmission Provider (for the benefit of the Transmission Owner) with a letter of credit from an agreed provider or other form of security reasonably acceptable to the Transmission Provider and that names the Transmission Provider as beneficiary (“Security”) in the amount of \$0. This amount represents the sum of the estimated Costs, determined consistent with Section 217 in Part VI of the Tariff, of (i) the Local Upgrades and/or Network Upgrades described in Section 3.4 of this WMPA less any Costs already paid by the Wholesale Market Participant. Should Wholesale Market Participant fail to provide Security in the amount or form required in the first sentence of this Section, this WMPA shall be terminated. Wholesale Market Participant acknowledges that its ultimate cost responsibility consistent with Section 217 in Part VI of the Tariff will be based upon the actual Costs of the facilities described in the Specifications to this WMPA, whether greater or lesser than the amount of the Security provided under this Section.
- 3.1 Project Specific Milestones.** During the term of this WMPA, Wholesale Market Participant shall ensure that it meets each of the following milestones:
- 3.1.1 Substantial Site work completed.** On or before August 31, 2017 Wholesale Market Participant must demonstrate completion of at least 20% of project site construction.
- 3.1.2 Commercial Operation.** (i) On or before March 30, 2018, Wholesale Market Participant must demonstrate commercial operation of all generating units; (ii) On or before October 27, 2017, Wholesale Market Participant must demonstrate commercial sale or use of energy and, if applicable obtain capacity qualification consistent with the requirements of the Reliability Assurance Agreement Among Load Serving Entities in the PJM Region.
- 3.1.3 Documentation.** Within one (1) month following commercial operation of generating unit(s), Wholesale Market Participant must provide certified documentation demonstrating that “as-built” Participant Facility are consistent with applicable PJM studies and agreements. Wholesale Market Participant must also provide PJM with “as-built” electrical modeling data or confirm that previously submitted data remains valid.
- 3.1.4 Interconnection Agreement.** On or before April 15, 2017, Wholesale Market Participant must enter into an Interconnection Agreement with the Transmission Owner in order to effectuate the WMPA.



ARTICLE 3 – Responsibility for Network or Local Upgrades

- 3.0 Security for Network or Local Upgrades.** Consistent with Section 212.4 in Part VI of the Tariff, Wholesale Market Participant, on or before the effective date of this WMPA, shall provide the Transmission Provider (for the benefit of the Transmission Owner) with a letter of credit from an agreed provider or other form of security reasonably acceptable to the Transmission Provider and that names the Transmission Provider as beneficiary (“Security”) in the amount of \$0. This amount represents the sum of the estimated Costs, determined consistent with Section 217 in Part VI of the Tariff, of (i) the Local Upgrades and/or Network Upgrades described in Section 3.4 of this WMPA less any Costs already paid by the Wholesale Market Participant. Should Wholesale Market Participant fail to provide Security in the amount or form required in the first sentence of this Section, this WMPA shall be terminated. Wholesale Market Participant acknowledges that its ultimate cost responsibility consistent with Section 217 in Part VI of the Tariff will be based upon the actual Costs of the facilities described in the Specifications to this WMPA, whether greater or lesser than the amount of the Security provided under this Section.
- 3.1 Project Specific Milestones.** During the term of this WMPA, Wholesale Market Participant shall ensure that it meets each of the following milestones:
- 3.1.1 Substantial Site work completed.** On or before August 31, 2017 Wholesale Market Participant must demonstrate completion of at least 20% of project site construction.
- 3.1.2 Commercial Operation.** (i) On or before March 30, 2018, Wholesale Market Participant must demonstrate commercial operation of all generating units; (ii) On or before October 27, 2017, Wholesale Market Participant must demonstrate commercial sale or use of energy and, if applicable obtain capacity qualification consistent with the requirements of the Reliability Assurance Agreement Among Load Serving Entities in the PJM Region.
- 3.1.3 Documentation.** Within one (1) month following commercial operation of generating unit(s), Wholesale Market Participant must provide certified documentation demonstrating that “as-built” Participant Facility are consistent with applicable PJM studies and agreements. Wholesale Market Participant must also provide PJM with “as-built” electrical modeling data or confirm that previously submitted data remains valid.
- 3.1.4 Interconnection Agreement.** On or before April 15, 2017, Wholesale Market Participant must enter into an Interconnection Agreement with the Transmission Owner in order to effectuate the WMPA.

ARTICLE 3 – Responsibility for Network or Local Upgrades

- 3.0 Security for Network or Local Upgrades.** Consistent with Section 212.4 in Part VI of the Tariff, Wholesale Market Participant, on or before the effective date of this WMPA, shall provide the Transmission Provider (for the benefit of the Transmission Owner) with a letter of credit from an agreed provider or other form of security reasonably acceptable to the Transmission Provider and that names the Transmission Provider as beneficiary (“Security”) in the amount of \$0. This amount represents the sum of the estimated Costs, determined consistent with Section 217 in Part VI of the Tariff, of (i) the Local Upgrades and/or Network Upgrades described in Section 3.4 of this WMPA less any Costs already paid by the Wholesale Market Participant. Should Wholesale Market Participant fail to provide Security in the amount or form required in the first sentence of this Section, this WMPA shall be terminated. Wholesale Market Participant acknowledges that its ultimate cost responsibility consistent with Section 217 in Part VI of the Tariff will be based upon the actual Costs of the facilities described in the Specifications to this WMPA, whether greater or lesser than the amount of the Security provided under this Section.
- 3.1 Project Specific Milestones.** During the term of this WMPA, Wholesale Market Participant shall ensure that it meets each of the following milestones:
- 3.1.1 Substantial Site work completed.** On or before August 31, 2017 Wholesale Market Participant must demonstrate completion of at least 20% of project site construction.
- 3.1.2 Commercial Operation.** (i) On or before March 30, 2018, Wholesale Market Participant must demonstrate commercial operation of all generating units; (ii) On or before October 27, 2017, Wholesale Market Participant must demonstrate commercial sale or use of energy and, if applicable obtain capacity qualification consistent with the requirements of the Reliability Assurance Agreement Among Load Serving Entities in the PJM Region.
- 3.1.3 Documentation.** Within one (1) month following commercial operation of generating unit(s), Wholesale Market Participant must provide certified documentation demonstrating that “as-built” Participant Facility are consistent with applicable PJM studies and agreements. Wholesale Market Participant must also provide PJM with “as-built” electrical modeling data or confirm that previously submitted data remains valid.
- 3.1.4 Interconnection Agreement.** On or before April 15, 2017, Wholesale Market Participant must enter into an Interconnection Agreement with the Transmission Owner in order to effectuate the WMPA.
- JLM- 2/24/17