

PJM Facilities Study Report
For
Network Upgrade N9153
Transition Cycle #1

June 2025

Introduction

This Facilities Study has been prepared in accordance with the PJM Open Access Transmission Tariff and PJM Manuals. The Transmission Owner (TO) is Virginia Electric and Power Company (VEPCO or Dominion).

A. Project Description

The System Impact Study for PJM Interconnection Transition Cycle #1 has identified the need for PJM Network Upgrade N9153. The scope of this Network Upgrade includes the following:

- Upgrade 5.9 Miles of 230kV transmission line 2128 from Fentress Substation to Thrasher Substation

B. Transmission Owner Facilities Study Results

1. Detailed Scope of work for Network Upgrade N9153:

The following is a detailed description of Transmission Owner Upgrades for Network Upgrade N9153. These facilities shall be designed according to the Transmission Owner's Applicable Technical Requirements and Standards. Once built the Transmission Owner will own, operate, and maintain these facilities.

See Preliminary Scoping Summaries located in the Appendices, Attachment #1, #2 and #3

2. MILESTONE SCHEDULE FOR COMPLETION OF DOMINION WORK

Facilities outlined in this report are estimated to take 43 months to construct, from the time of full execution of the Generation Interconnection Agreement and completion of a construction kickoff call. This schedule may be impacted by the timeline for procurement and installation of long lead items and the ability to obtain outages to construct and test the proposed facilities.

Description	Start month	Finish month
Engineering	1	30
Permitting/Procurement	3	38
Construction	36	43

Due to outage congestion, Network Upgrades and/or internal Dominion projects have been identified as having possible outage conflicts with this network upgrade that may affect the estimated milestones listed above. Additional outage sequencing may be required that includes, but not limited to the following projects:

3. ASSUMPTIONS IN DEVELOPING SCOPE/COST/SCHEDULE

- Work on line 2110
- The preliminary construction schedule is dependent on outage availability.
- See Attachment 1 and 2– Preliminary Scoping Summary – Substation for additional assumptions
- See Attachment 3 – Preliminary Scoping Summary – Transmission line for additional assumptions

4. LAND REQUIREMENTS

Dominion will be responsible for the following expectations in the area of Real Estate:

- Any additional land needed for Storm Water Management, Landscaping, and Wetlands/Wetlands Mitigation.
- Any other Land/Permitting requirements required by the Network Upgrade

5. ENVIRONMENTAL AND PERMITTING

The Dominion will be responsible for the following expectations in the area of Environmental and Permitting:

- Assessment of environmental impacts related to the Network Upgrade including:
 - Environmental Impact Study requirements
 - Environmental Permitting
- A stormwater easement and/or specific stormwater design BMP's to allow access to and use of the facilities, including a maintenance agreement for said stormwater facilities.
- Conditional Use Permit for Substation
- Any additional land needed for Storm Water Management, Landscaping, and Wetlands/Wetlands Mitigation
- Any other Permitting requirements required by the Network Upgrade

C. APPENDICES

- Attachment #1: Preliminary Scoping Summary – Substation Fentress
- Attachment #2: Preliminary Scoping Summary – Substation Thrasher
- Attachment #3: Preliminary Scoping Summary – Transmission



Project Number: N9153 – Fentress Substation
Project Description: ***SUBSTATION SCOPE OF WORK*** Replace Line Lead for Line 2128

Date: 06/20/2025
Revision Number: 0

Project Summary

Network upgrade N9153 provides for the uprate of line 2128 at Fentress Substation in Chesapeake, Virginia.

Purchase and install substation material – Network Upgrade:

1. Conductors, connectors, and grounding materials as per engineering standards

Purchase and install relay material – Network Upgrade:

1. One (1), 1340 – 24” dual SEL-411L DCB/PLC line panel

Remove relay material – Network Upgrade:

1. Remove Panel No.5



Project Number: N9153 – Thrasher Substation
Project Description: ***SUBSTATION SCOPE OF WORK***
Replace Line Lead for Line 2128

Date: 06/20/2025

Revision Number: 0

Project Summary

Network upgrade N9153 provides for the uprate of line 2128 at Thrasher Substation in Chesapeake City, Virginia.

Purchase and install substation material – Network Upgrade:

2. Conductors, connectors, and grounding materials as per engineering standards

Purchase and install relay material – Network Upgrade:

2. One (1), 1340 – 24” dual SEL-411L DCB/PLC line panel

Remove relay material – Network Upgrade:

1. Remove Panel No. 11

230kV LINE #2128
FENTRESS - THRASHER
PROJECT N9153

PRELIMINARY SCOPING SUMMARY

This project serves to wreck and rebuild 230kV Line 2128 between structure 2128/1A (269/1A) inside Fentress Substation to structure 2128/45 (231/51) inside Thrasher Substation for approximately 5.90 miles, which is located in Chesapeake, VA. See **Figure 1** for the project location. The proposed work will require additional right of way (ROW) in certain areas of the project. The project will install a total of forty-three (43) structures. A Certificate of Public Convenience and Necessity (CPCN) filing is expected due to the quantity of structures that will need to be replaced as part of this project.

The existing line is mainly comprised of double circuit weathered steel monopole suspension and deadend structures constructed in 1985. The proposed structures to be installed are engineered double circuit 230kV steel suspension and deadend monopole structures on foundations. The existing single (1) 2500 ACAR (84/7), twin bundled (2) 721 ACAR (18/19), and twin bundled (2) 636 ACSR (24/7) "Rook" conductor will be replaced with twin bundled (2) 768.2 ACSS/TW/HS (20/7) "Maumee" conductor. The existing single (1) 3#6 Alumoweld shield wire will be replaced with two (2) DNO-11410 OPGW.

From Fentress substation to existing structure 2128/43 (I279/43), the double circuit structures support the Idle Line 279 conductor. This conductor will be removed as part of this project, but no conductor will be re-installed for this segment of the Idle Line.

It is assumed that an outage for Line 2128 will be acquired for the work specified in this scope, and no temporary line configurations will be necessary for this project.

Design Considerations:

EXISTING FACILITIES TO BE REMOVED:

1. Remove fifteen (15) existing 230kV double circuit double deadend steel monopole structures as follows:
 - a. Structures 2128/1 (I279/1), 2128/2 (I279/2), 2128/4 (I279/4) to 2128/6 (I279/6), 2128/8 (I279/8), 2128/17 (I279/17) to 2128/18 (I279/18), 2128/21 (I279/21), 2128/25 (I279/25), 2128/28 (I249/28), 2128/30 (I279/30), 2128/34 (I279/34), 2128/39 (I279/39), and 2128/42 (I279/42)
2. Remove one (1) existing 230kV double circuit double deadend steel h-frame structure as follows:
 - a. Structure 2128/43 (279/43)
3. Remove twenty-four (24) existing 230kV double circuit suspension steel monopole structures as follows:

- a. Structures 2128/3 (I279/3), 2128/7 (I279/7), 2128/9 (I279/9) to 2128/16 (I279/16), 2128/20 (I279/20), 2128/22 (I279/22) to 2128/24 (I279/24), 2128/26 (I279/26) to 2128/27 (I279/27), 2128/31 (I279/31) to 2128/32 (I279/32), 2128/35 (I279/35) to 2128/38 (I279/38), and 2128/40 (I279/40) to 2128/41 (I279/41)
4. Remove three (3) existing 230kV double circuit running angle steel monopole structures as follows:
 - a. Structures 2128/19 (I279/19), 2128/29 (I279/29), and 2128/33 (I279/33)
5. Remove approximately 0.16 miles of 3-phase single (1) 2500 ACAR (84/7) conductor from the **Line 2128 ahead side** of backbone structure 2128/1A (269/1A) inside Fentress Substation to the **back side** of structure 2128/2 (I279/2).
6. Remove approximately 5.70 miles of 3-phase twin bundled (2) 721 ACAR (18/19) conductor from the **Line 2128 ahead side** of structure 2128/2 (I279/2) to the **back side** of structure 2128/43.
7. Remove approximately 0.04 miles of 3-phase twin bundled (2) 636 ACSR (24/7) "Rook" conductor from the **Line 2128 ahead side** of structure 2128/44 to the **back side** of backbone structure 2128/45 (231/51) inside Thrasher Substation.
8. Remove approximately 5.86 miles of single (1) 3#6 Alumoweld shield wire from the **ahead side** of backbone structure 2128/1A (269/1A) inside Fentress Substation to the **back side** structure 2128/43 outside Thrasher Substation.
9. Remove one (1) set of 3-phase twin bundled (2) 636 ACSR (24/7) "Rook" conductor risers from the following structure:
 - a. Structure 2128/44
10. Remove approximately 0.16 miles of 3-phase single (1) 2500 ACAR (84/7) conductor on **Line I279** from the **ahead side** of backbone structure I279/1A (2087/1A) inside Fentress Substation to the **back side** of structure 2128/2 (I279/2)
11. Remove approximately 5.70 miles of 3-phase twin bundled (2) 721 ACAR (18/19) conductor on **Line I279** from the **ahead side** of structure 2128/2 (I279/2) to the **back side** of structure 2128/43 (279/43).
12. Remove approximately 5.86 of single (1) DNO-11410 OPGW from the **ahead side** of backbone structure I279/1C (2087/1A) inside Fentress Substation to the **back side** of structure 2128/43 (279/43).

EXISTING FACILITIES TO BE MODIFIED:

1. Replace three (3) 230kV bundled conductor crossing strain assemblies with three (3) 230kV bundled conductor crossing strain assemblies [32.338] as follows on the following three (3)

structures:

- a. Three (3) strain assemblies on backbone structures 2128/1A (269/1A) and 2128/45 (231/51)
 - b. Three (3) strain assemblies on the **ahead side** of structure 2128/44
2. Replace one (1) non-insulated shield wire strain assembly and one (1) shield wire safety catch assembly with one (1) non-insulated OPGW strain assembly [96.061] and one (1) OPGW safety catch assembly [96.100] on the following structure:
 - a. Structure 2128/1A (269/1A)
 3. Transfer existing 3-phase single (1) 2500 ACAR (84/7) conductor for **Line 279** from the **back side** of existing structure 279/44 to the **ahead side** of new structure 2128/43 (279/43) outside of Thrasher Substation.
 4. Transfer existing single (1) DNO-11410 OPGW for **Line 279** from the **back side** of existing structure 279/44 to the **ahead side** of new structure 2128/43 (279/43) outside of Thrasher Substation.

PERMANENT FACILITIES TO BE INSTALLED:

1. Install eighteen (18) 230kV double circuit double deadend engineered steel monopole structures [12.614] on foundations as follows:
 - a. Structures 2128/1 (I279/1), 2128/2 (I279/2), 2128/4 (I279/4) to 2128/6 (I279/6), 2128/8 (I279/8), 2128/17 (I279/17) to 2128/19 (I279/19), 2128/21 (I279/21), 2128/25 (I279/25), 2128/28 (I279/28) to 2128/30 (I279/30), 2128/33 (I279/33) to 2128/34 (I279/34), 2128/39 (I279/39), and 2128/42 (I279/42)
 - i. See **Figure 2** for a visual depiction of the proposed structure design.
2. Install twenty-four (24) 230kV double circuit suspension engineered steel monopole structures [12.610] on foundations as follows:
 - a. Structures 2128/3 (I279/3), 2128/7 (I279/7), 2128/9 (I279/9) to 2128/16 (I279/16), 2128/20 (I279/20), 2128/22 (I279/22) to 2128/24 (I279/24), 2128/26 (I279/26) to 2128/27 (I279/27), 2128/31 (I279/31) to 2128/32 (I279/32), 2128/35 (I279/35) to 2128/38 (I279/38), and 2128/40 (I279/40) to 2128/41 (I279/41)
 - i. See **Figure 3** for a visual depiction of the proposed structure design.
3. Install one (1) 230kV double circuit double deadend engineered steel h-frame structure [12.215] on foundations as follows:
 - a. Structure 2128/43 (I279/43)
 - i. See **Figure 4** for a visual depiction of the proposed structure design.
4. Install approximately 5.86 miles of 3-phase twin bundled (2) 768.2 ACSS/TW/HS (20/7) "Maumee" conductor for **Line 2128** from existing backbone structure 2128/1A (269/1A) inside Fentress Substation to proposed structure 2128/43 (I279/43).

5. Install approximately 0.04 miles of 3-phase twin bundled (2) 768.2 ACSS/TW/HS (20/7) “Maumee” conductor for the **Line 2128 side** from existing structure 2128/44 to existing backbone 2128/45 inside Thrasher Substation.
6. Install approximately 5.80 miles of two (2) DNO-11410 OPGW from proposed structure 2128/1 (I279/1) to the **back side** of proposed structure 2128/43 (279/43) outside of Thrasher Substation.
 - a. This includes the installation of eight (8) fiber splices on the following four (4) structures as follows:
 - i. Two (2) fiber splices on structures 2128/1 (I279/1), 2128/17 (I279/17), 2128/30 (I279/30), and 2128/43 (I279/43)
7. Install approximately 0.07 miles of single (1) DNO-11410 OPGW from the existing backbone 2128/1A (269/1A) inside Fentress Substation to the west static arm of proposed structure 2128/1 (I279/1).
 - a. This includes the installation of one (1) fiber splices on the following one (1) structure as follows:
 - i. One (1) fiber splice on structures 2128/1A (269/1A)
8. Install approximately 0.07 miles of single (1) 7#7 Alumoweld shield wire from the existing backbone 2128/1A (269/1A) inside Fentress Substation to the west static arm of proposed structure 2128/1 (I279/1).
9. Install one (1) set of 3-phase twin bundled (2) 768.2 ACSS/TW/HS (20/7) “Maumee” risers on the following structure:
 - a. Structure 2128/44

CONCEPTUAL SCOPE NOTES:

1. No PLS-CADD modeling was done for this project. Instead, a design span was used to determine the difference in sags between the existing and proposed conductors at max sag conditions. The resulting change in max sags between twin bundled (2) 768.2 ACSS/TW/HS “Maumee” conductor and twin bundled (2) 721 ACAR (18/19) is approximately 4.55 feet. Additionally, the resulting change in max sags between twin bundled (2) 768.2 ACSS/TW/HS “Maumee” conductor and single (1) 2500 ACAR (84/7) is approximately 10 feet. These changes in sag are substantial enough to assume that the line must be rebuilt.

Additionally, the resulting change in max sags between twin bundled (2) 768.2 ACSS/TW/HS “Maumee” conductor and twin bundled (2) 636 ACSR (24/7) “Rook” conductor is approximately 0.47 feet. These changes in sag indicate that it is feasible to reconductor this segment of the line.
2. Structures are designed based off the following NESC code parameters: NESC Heavy, 90 mph wind, $\frac{3}{4}$ ” Ice & 30 mph wind regardless of project location.
3. It is assumed for detailed engineering that a LiDAR survey will be required.

4. Any potential height restrictions were not accounted for in this design.
5. The existing right of way varies within the project based on MapViewer and PNPs. See below for the ROW widths and details in the project area:
 - a. 80 ft from existing structure 2128/1A inside Fentress Substation to existing structure 2128/17 (I279/17)
 - i. The existing structures will be replaced like for like on the existing centerline. From existing centerline to the edge of ROW on the north side is 60 ft. Line 2128 will be strung on this portion of the corridor. It is assumed that no additional ROW will need to be required in this area due to being able to meet forestry and appropriate blow-out clearances. However, if an additional circuit is strung on the proposed structures or if the existing centerline is shifted, ROW may need to be acquired.
 - b. 50 ft from existing structure 2128/41 (I279/42) to existing structure 2128/43 outside Thrasher substation.
 - i. An additional 50ft of ROW will need to be required between existing structure 2128/41 and 2128/43 for approximately 0.31 miles.
 - ii. This project assumes that the existing structures will be installed on the existing centerline. Line 2128 will be strung on the north side, which is approximately 30 ft from the existing centerline to edge of ROW. It is assumed that this would not meet the forestry and appropriate blow-out clearances. Due to existing ROW limits to existing railroad and overhead distribution line, there may be a pole line easement in place, which will need to be confirmed and analyzed in detailed engineering. If additional ROW is unable to be acquired, an alternative solution may be to acquire project specific approval to not meet typical minimum ROW requirements.
 - c. Undefined ROW between existing structures 2128/17 to existing structure 2128/41
 - i. The existing structures will be replaced like for like on the existing centerline. Due to existing railroad and overhead distribution lines, it is assumed there may be a pole line easement in this area. In detailed engineering, this will need to be confirmed and analyzed. If additional ROW is unable to be acquired, alternative solution may be to acquire project specific approval to not meet typical minimum ROW requirements.
6. A wetland delineation has not been completed as part of this conceptual package.
7. Deadend structure have been incorporated into the line design to accommodate the 12,000 foot wire reels, thereby eliminated the need for tension splices. The exact pull pad locations will be determined during the detailed design phase.
8. The following critical crossings exist along Line 2128 between the following existing structures:
 - a. Norfolk Southern railroad:
 - i. Between structures 2128/7 (I279/7) and 2128/8 (I279/8)
 - ii. Between structures 2128/38 (I279/38) and 2128/39 (I279/39)

- b. Elizabeth River:
 - i. Between structures 2128/20 (I279/20) and 2128/21 (I279/21)
 - c. Virginia State Route 190:
 - i. Between structures 2128/33 (I279/33) and 2128/34 (I279/34)
 - d. Distribution line:
 - i. Between structures 2128/7 (I279/7) and 2128/8 (I279/8)
 - ii. Between structures 2128/13 (I279/13) and 2128/14 (I279/14)
 - iii. Between structures 2128/15 (I279/15) and 2128/16 (I279/16)
 - iv. Between structures 2128/28 (I279/28) and 2128/29 (I279/29)
9. It is assumed when removing Idle Line 279 from Fentress to structure 2128/43 (279/43) that no conductor needs to be re-strung. The structures will be replaced like for like with double circuit monopole structures. One side will remain vacant with arm dampers to not limit the corridor in the future. If it's preferred to utilize alternative design in detailed engineering, additional ROW may need to be acquired.
10. Project N9153 assumes that Fentress substation can have one (1) fiber going into the substation. In detailed engineering, this project will need to discuss this design approach with the telecommunications group.

CONCEPTUAL ESTIMATE NOTES:

1. Engineered steel pole costs were determined based off typical wind and weight spans, line angles, and average structure heights in the typical right of way associated with the structure type.
2. Steel pole foundation costs were based off the projects' location and structure type in the regional soil profile map. The regional soil profile map used for this project is Coastal Plains East.
3. The conceptual estimate assumes that a laydown yard is required for this project.
4. Prior to detailed engineering, a full land rights review would be required. A desktop review was completed to estimate the project cost.
5. Access estimate cost inputs include the following assumptions:
 - a. No costs projected for encroachments due to fences/sheds that may need to be removed.
 - b. Specialty matting used at 2 structures drove up the cost by \$1.3 million - there is an added 10% contingency already to the price. These are assumed to be duration based rentals and pad sizes based on 230kV circuit rebuilds. If duration is longer or pad sizes are larger, costs will increase.
 - c. Assuming crane mats count for additional work pads in large drainage ditches. -

\$400,000

- d. Tangent Structures are allotted 30 mats. Angle structures are allotted 60 mats. Pull Pads are allotted 90 mats for the 115kV and 230kV Wreck and Rebuild and New Lines.
- e. DDE structures assumed based off of wire reel lengths - based off of pull pad locations.
- f. Pull pad locations based on location of major road/water crossings and line mileage.
- g. Assuming that existing stone in Substations will be used for access per SOW and that access is existing or will be built by others before the start of construction. Assumes that the substations will be constructed with access roads built to and from Substations and work from inside the substations for Backbone installation.
- h. Assumes no delays due to permitting or real estate issues after work begins. Assume no schedule compressions from SOC/PJM.
- i. Access matting costs not accounted for forestry work in between large spans that were not matted through for access.
- j. Stream crossing based on estimates from aerial imagery.
- k. Assumes that all existing roads may be dressed with stone that can remain at the end of the project. Assumes existing two track roads in many locations will be impermeable. No costs for stone road removal are included.
- l. Assumes between a 10-20% Markup for contingency on Emtek specialty matting dependent on size and scope of material to be used in each project that requires the specialty matting in swamp/wetlands. Markup applied in Success.

Figure 1 – Project Location

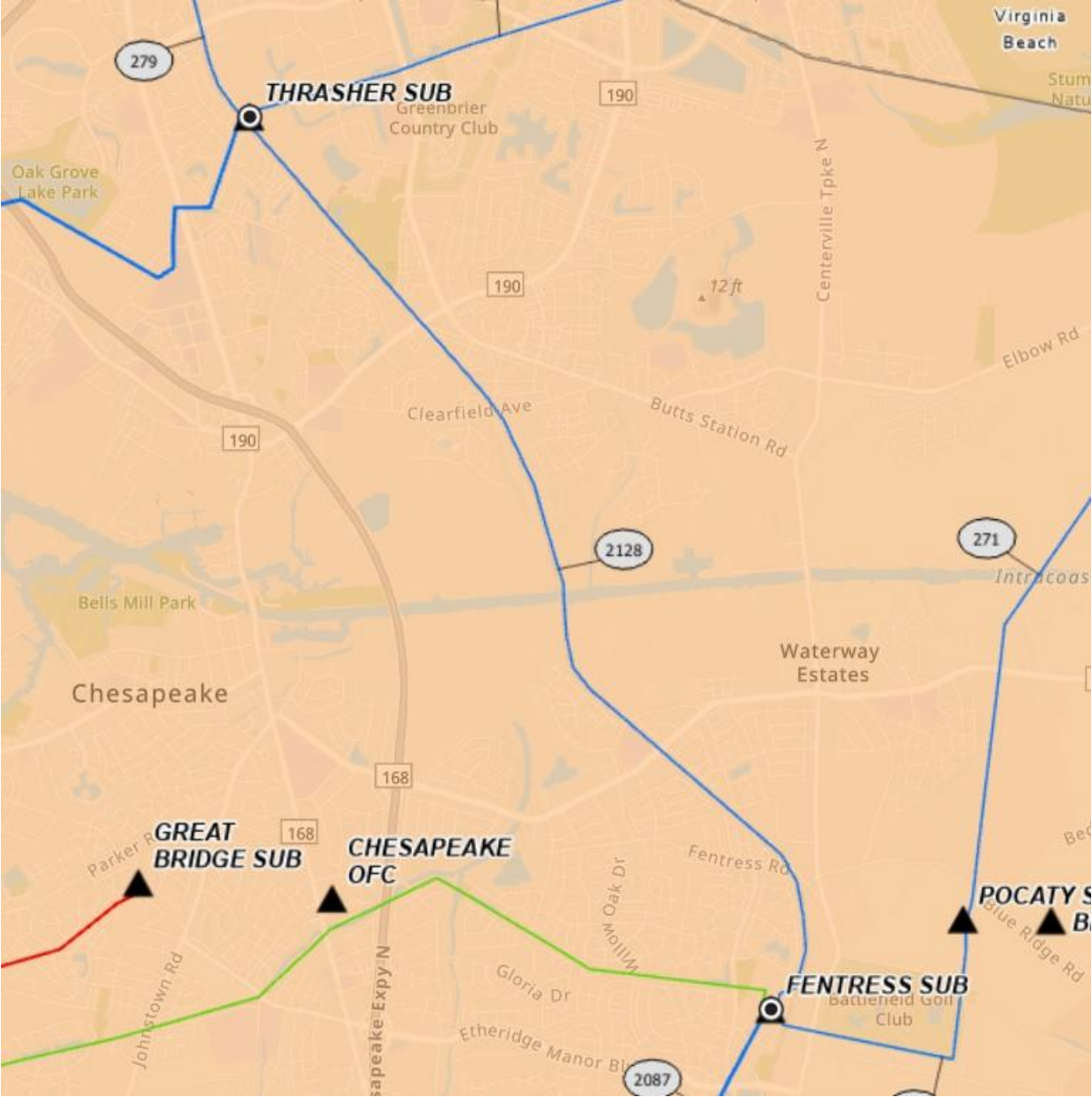

Figure 2 – Proposed Double Deadend Structure Configuration

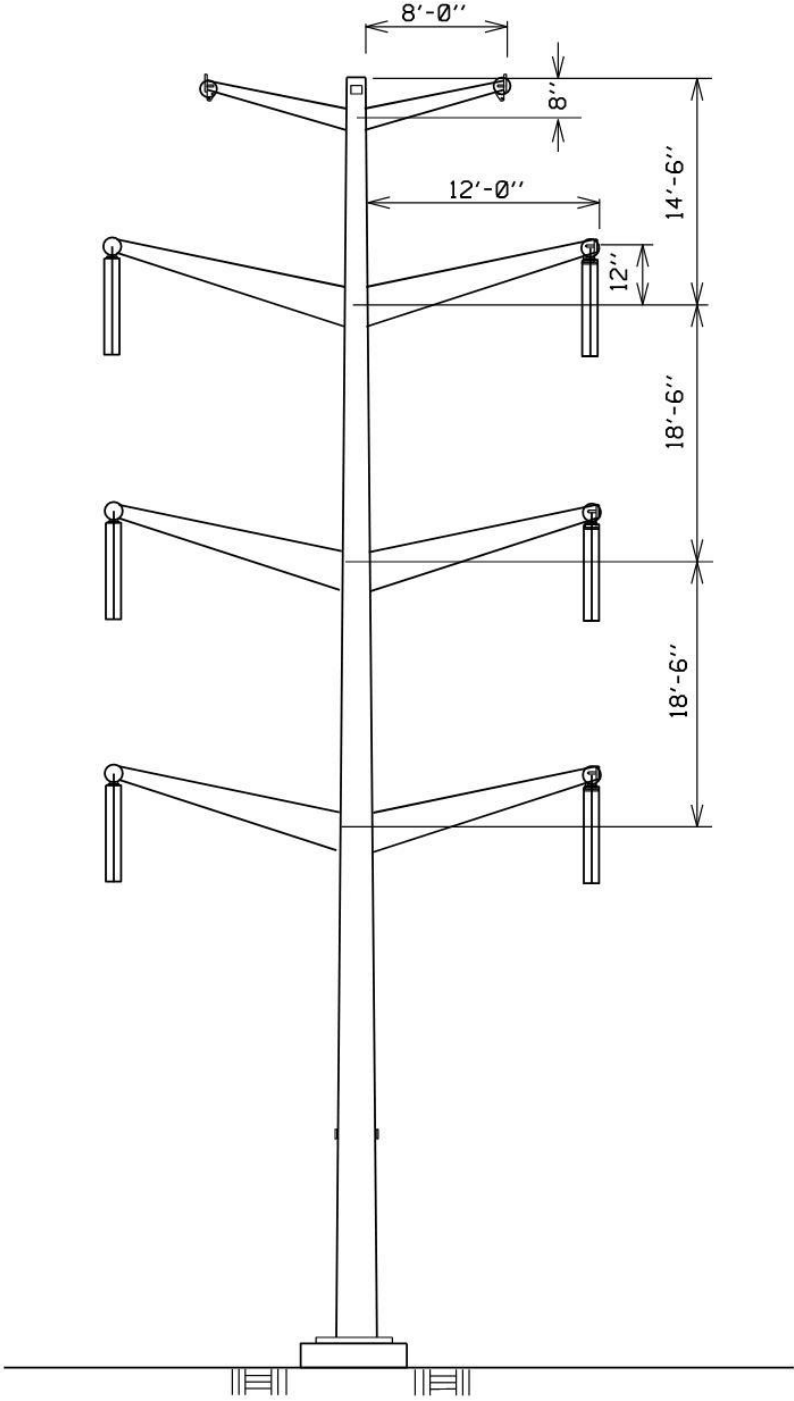

Figure 3 – Proposed Suspension Structure Configuration

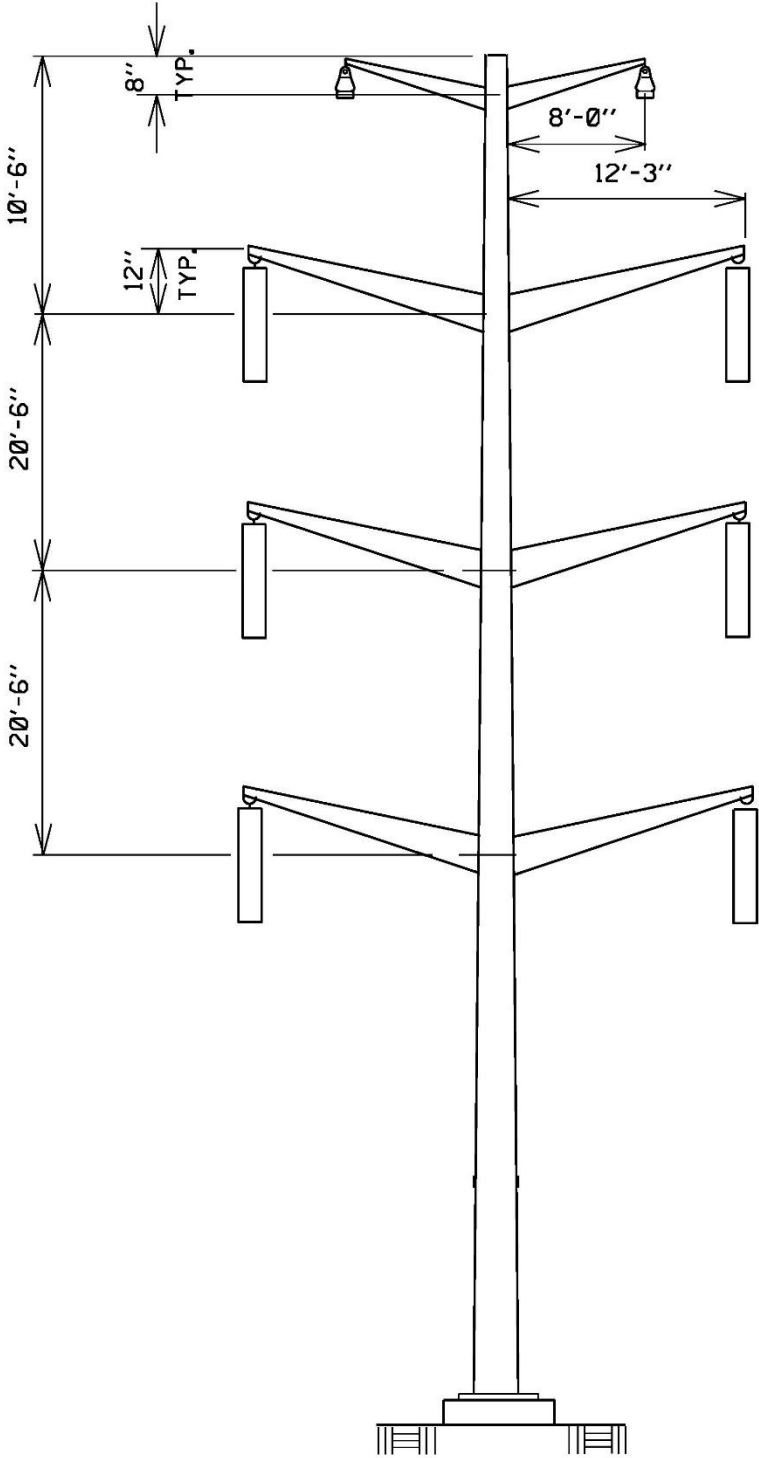
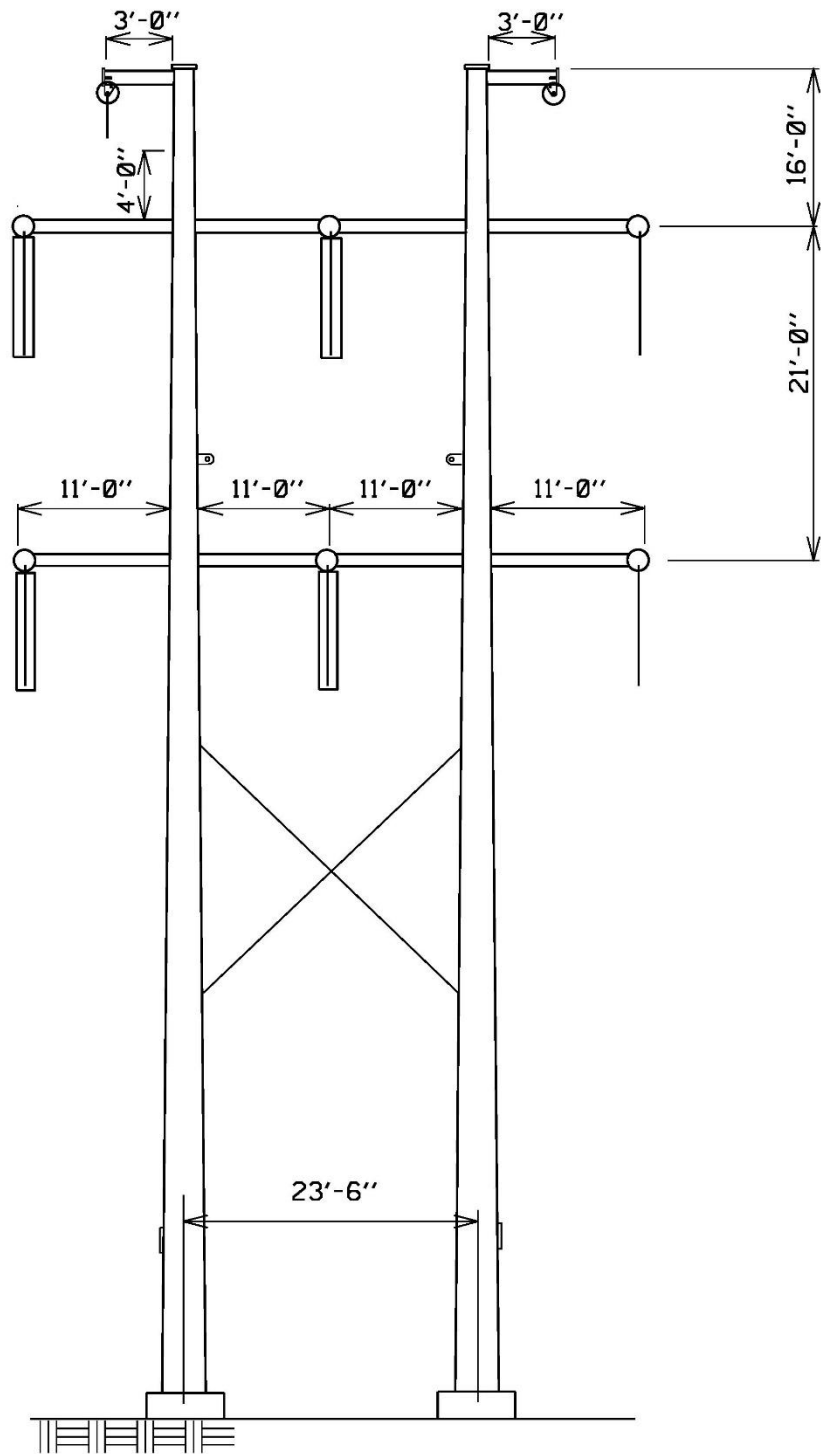

Figure 4 – Proposed H-Frame Structure Configuration



Required Material Summary

Item	Qty
230kV DC DDE Steel Monopoles [12.614]	18
230kV DC Suspension Steel Monopoles [12.610]	24
230kV DC DDE Steel H-Frame [12.215]	1
12,000-Ft DNO-11410 OPGW	6
12,000-Ft 768.2 ACSS/TW/HS "Maumee" Conductor Reels	18