

PJM Facilities Study Report
For
Network Upgrade N9199
Transition Cycle #1

June 2025

Introduction

This Facilities Study has been prepared in accordance with the PJM Open Access Transmission Tariff and PJM Manuals. The Transmission Owner (TO) is Virginia Electric and Power Company (VEPCO or Dominion).

A. Project Description

The System Impact Study for PJM Interconnection Transition Cycle #1 has identified the need for PJM Network Upgrade N9199. The scope of this Network Upgrade includes the following:

- Upgrade 1.63 Miles of 230kV transmission line 2193 from Bremo Substation to Structure 2193/173

B. Transmission Owner Facilities Study Results

1. Detailed Scope of work for Network Upgrade N9199:

The following is a detailed description of Transmission Owner Upgrades for Network Upgrade N9199. These facilities shall be designed according to the Transmission Owner's Applicable Technical Requirements and Standards. Once built the Transmission Owner will own, operate, and maintain these facilities.

See Preliminary Scoping Summaries located in the Appendices, Attachment #1, #2 and #3.

2. MILESTONE SCHEDULE FOR COMPLETION OF DOMINION WORK

Facilities outlined in this report are estimated to take 42 months to construct, from the time of full execution of the Generation Interconnection Agreement and completion of a construction kickoff call. This schedule may be impacted by the timeline for procurement and installation of long lead items and the ability to obtain outages to construct and test the proposed facilities.

Description	Start month	Finish month
Engineering	1	30
Permitting/Procurement	3	38
Construction	36	42

Due to outage congestion, Network Upgrades and/or internal Dominion projects have been identified as having possible outage conflicts with N7568 that may affect the estimated milestones listed above. Additional outage sequencing may be required that includes, but not limited to, the following projects:

- AF1-125

3. ASSUMPTIONS IN DEVELOPING SCOPE/COST/SCHEDULE

Rebuild of line 2028

- The preliminary construction schedule is dependent on outage availability.
- See Attachment 1 and 2– Preliminary Scoping Summary – Substation for additional assumptions
- See Attachment 3 – Preliminary Scoping Summary – Transmission line for additional assumptions

4. LAND REQUIREMENTS

Dominion will be responsible for the following expectations in the area of Real Estate:

- Any additional land needed for Storm Water Management, Landscaping, and Wetlands/Wetlands Mitigation.
- Any other Land/Permitting requirements required by the Network Upgrade

5. ENVIRONMENTAL AND PERMITTING

The Dominion will be responsible for the following expectations in the area of Environmental and Permitting:

- Assessment of environmental impacts related to the Network Upgrade including:
 - Environmental Impact Study requirements
 - Environmental Permitting
- A stormwater easement and/or specific stormwater design BMP's to allow access to and use of the facilities, including a maintenance agreement for said stormwater facilities.
- Conditional Use Permit for Substation
- Any additional land needed for Storm Water Management, Landscaping, and Wetlands/Wetlands Mitigation
- Any other Permitting requirements required by the Network Upgrade

C. APPENDICES

- Attachment #1: Preliminary Scoping Summary – Substation Bremono
- Attachment #2: Preliminary Scoping Summary – Substation Fork Union
- Attachment #3: Preliminary Scoping Summary – Transmission



Project Number: N9199 – Bremo Substation

Project Description: ***SUBSTATION SCOPE OF WORK*** Replace Line Lead for Line 2193

Date: 06/20/2025

Revision Number: 0

Project Summary

Network upgrade n9199 provides for the uprate of line 2193 at Bremo Substation in Fluvanna County, Virginia.

Purchase and install substation material – Network Upgrade:

1. Conductors, connectors, and grounding materials as per engineering standards

Purchase and install relay material – Network Upgrade:

1. One (1), 1340 – 24” dual SEL-411L CD/Fiber line panel

Remove relay material – Network Upgrade:

1. Remove Panel No. 23



Project Number: N9199 – Fork Union Substation
Project Description: ***SUBSTATION SCOPE OF WORK*** Replace Line Lead for Line 2193

Date: 06/20/2025
Revision Number: 0

Project Summary

Network upgrade N9199 provides for the uprate of line 2193 at Fork Union Substation in Fluvanna County, Virginia.

Purchase and install substation material – Network Upgrade:

2. Conductors, connectors, and grounding materials as per engineering standards

Purchase and install relay material – Network Upgrade:

2. One (1), 1340 – 24” dual SEL-411L CD/Fiber line panel

Remove relay material – Network Upgrade:

1. Remove Panel No. 5

230 kV LINE #2193
Fork Union Substation – Bremono Substation
PROJECT N9199

PRELIMINARY SCOPING SUMMARY

This project serves to partially rebuild 230kV line 2193 from Bremono Substation to structure 2193/173 near Fork Union Substation for approximately 1.63 miles, which is located in Fluvanna County, VA. See **Figure 1** for the project location. The proposed work requires no additional land and will all be completed within the existing 262' right of way. This project will install a total of eleven (11) new structures. This project will require a CPCN filing.

Line 2193 consists mainly of wood and weathering steel H-frame and 3-pole structures built in 1981 and 1988. The proposed structures to be installed are direct embed DOM single circuit H-frame structures. Due to a portion of the weathering steel structures in line 2193 being installed within the last 15 years, these structures will not be replaced. The existing twin bundled (2) 721 ACAR conductor will be replaced with twin bundled (2) 768.2 ACSS/TW/HS "Maumee" conductor. The existing two (2) 3#6 Alumoweld shield wires will be replaced with two (2) DNO-11410 fiber.

It is assumed that an outage for line 2193 will be acquired for the work specified in this scope, and no temporary line configurations will be necessary for this project.

Design Considerations:

EXISTING FACILITIES TO BE REMOVED:

1. Remove eight (8) existing 230 kV single circuit wood suspension H-frames as follows:
 - a. Structures 2193/174-176, 179-181, 183, and 186
2. Remove two (2) existing 230 kV single circuit wood double deadend 3-pole structures as follows:
 - a. Structures 2193/182, and 185
3. Remove one (1) existing 230kV 3000 Amp self-supporting switch structure as follows:
 - a. Structure 2193/184
4. Remove approximately 1.63 miles of twin bundled (2) 721 ACAR from existing structure 2193/173 to existing backbone 2193/186A.
5. Remove approximately 1.63 miles of (2) 3#6 Alumoweld shield wire from existing structure 2193/173 to existing backbone 2193/186A.

EXISTING FACILITIES TO BE MODIFIED:

1. Replace two (2) I-string suspension assemblies [Reference Drawing 32.610] and one (1) V-string suspension conductor assembly [Reference Drawing 32.850] on the following three (3) structures:
 - a. Structures 2193/177, 178, and 184A

2. Replace three (3) conductor strain assemblies [Reference Drawing 32.338] and two (2) OPGW strain assemblies [Reference Drawing 96.060] on the following structure:
 - a. Structure 2193/186A

3. Replace three (3) conductor strain assemblies [Reference Drawing 32.630], three (3) conductor jumper loop assemblies [Reference Drawing 39.207], and two (2) OPGW strain assemblies [Reference Drawing 96.060] on the following structure:
 - a. Structure 2193/173

PERMANENT FACILITIES TO BE INSTALLED:

1. Install eight (8) 230kV direct embed DOM single circuit tangent H-frame structures [Reference Drawing 12.557] as follows:
 - a. Structures 2193/174-176, 179-181, 183, and 186
 - b. See **Figure 2** for a visual of the proposed structure design.

2. Install two (2) 230kV engineered steel single circuit 3-pole double deadend structures [Reference Drawing 12.158] on foundations as follows:
 - a. Structures 2193/182, and 185
 - b. See **Figure 3** for a visual of the proposed structure design

3. Install one (1) 230 kV 4000 amp self-supporting switch structure on foundations as follows:
 - a. Structure 2193/184

4. Install approximately 1.63 miles of 3-phase twin bundled (2) 768.2 ACSS/TW/HS (20/7) "Maumee" conductor from existing structure 2193/173 to existing backbone 2193/186A.

5. Install approximately 1.63 miles of two (2) DNO-11410 OPGW from existing structure 2193/173 to existing backbone 2193/186A.
 - a. This includes the installation of four (4) splices as follows:
 - i. Two (2) on structure 2193/173
 - ii. Two (2) on backbone 2193/186A

CONCEPTUAL SCOPE NOTES:

1. The existing line consists primarily of wood suspension single circuit H-frame structures built in 1981 and 1988. These structures are considered insufficient for the proposed conductor, resulting in the need for the line to be partially rebuilt.

The existing weathering steel H-frame and 3-pole structures were installed within the last 15 years and are assumed to be sufficient to remain. In detailed engineering, existing structures will need to be analyzed. No PLS-CADD modeling was done for this project. Structures were replaced like for like and estimated using typical transmission right of way characteristics.

2. Structures are designed based off the following NESC code parameters: NESC Heavy, 90 mph wind, $\frac{3}{4}$ " Ice & 30 mph wind regardless of project location.
3. It is assumed for detailed engineering that a LiDAR survey will be required.
4. Any potential height restrictions were not accounted for in this design.
5. An existing right of way width of 262' is assumed based on existing plan and profiles and map viewer. No new right of way is necessary.
6. A wetland delineation has not been completed as part of this conceptual package.
7. Wire reel lengths were not accounted for this line design. The assumed pull pad locations to avoid tension splices will be determined during detailed design.
8. Line 2193 shares the right of way corridor with line 1093, line 5, and an adjacent distribution line.
9. If projects 993450 or 992911 move forward, project N9199 scope is incorrect and will need to be re-analyzed.
10. This project scope assumes that project N9199 occurs prior to other network upgrades included in Transition Cycle 1 – Phase 3. The following project(s) may impact the project scope if this assumption is incorrect:
 - a. N9146 – Wreck and rebuild 1.51 miles of line 5 between Bremo and Fork Union
11. Critical crossings for project N9199 are:
 - a. Between structure 2193/185 and structure 2193/184A crossing line 5
 - b. Distribution lines near Bremo substation

CONCEPTUAL ESTIMATE NOTES:

1. Engineered steel pole costs were determined based off typical wind and weight spans, line angles, and average structure heights in the typical right of way associated with the structure type.
2. Steel pole foundation costs were based off the projects' location and structure type in the regional soil profile map. The regional soil profile map used for this project is Piedmont.
3. The conceptual estimate assumes that a laydown yard is required for this project.
4. Prior to detailed engineering, a full land rights review would be required. A desktop review was completed to estimate the project cost.
5. Access estimate cost inputs include the following assumptions:
 - a. Work pad totals based on provided SOW and assumptions from kmz file. Assume 15 mats for tangents and 30 mats for angles at each work pad for reconductor work and 50 mats per pull pad.
 - b. DDE structures assumed based off of wire reel lengths - based off of pull pad locations.
 - c. Pull pad locations based on location of major road/water crossings and line mileage.
 - d. Assuming that existing stone in Substations will be used for access per SOW and that access is existing or will be built by others before the start of construction. Assumes that the substations will be constructed with access roads built to and from Substations and work from inside the substations for Backbone installation.
 - e. Assumes no delays due to permitting or real estate issues after work begins. Assume no schedule compressions from SOC/PJM.
 - f. Assumes all clearing and forestry costs have been captured by others. No access costs for forestry activities included in this pricing.
 - g. Stream crossing based on estimates from aerial imagery.
 - h. Assumes that all existing roads may be dressed with stone that can remain at the end of the project. Assumes existing two track roads in many locations will be impermeable. No costs for stone road removal are included.

Figure 1 – Project Location

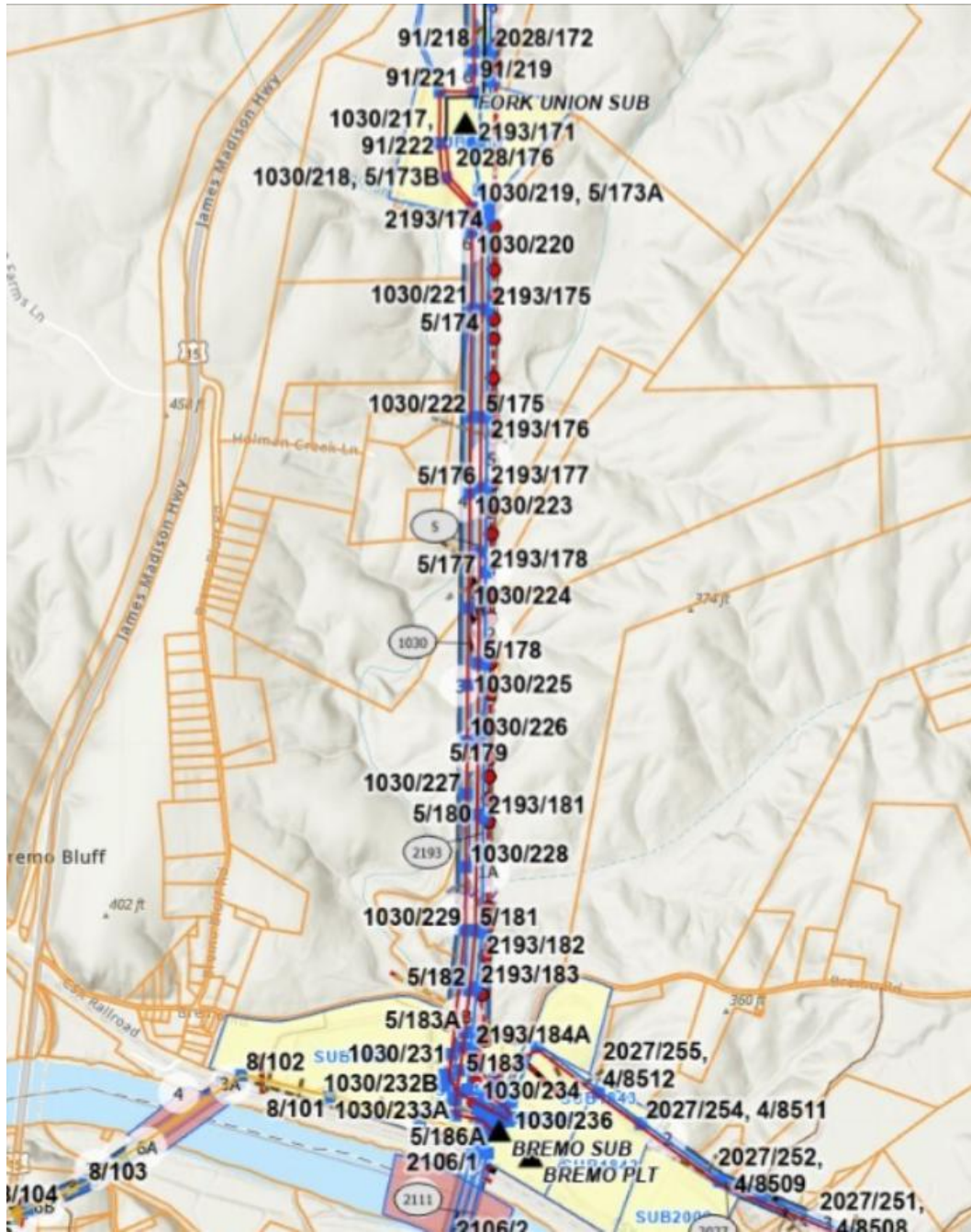

Figure 2 – Proposed Suspension Structure Configuration

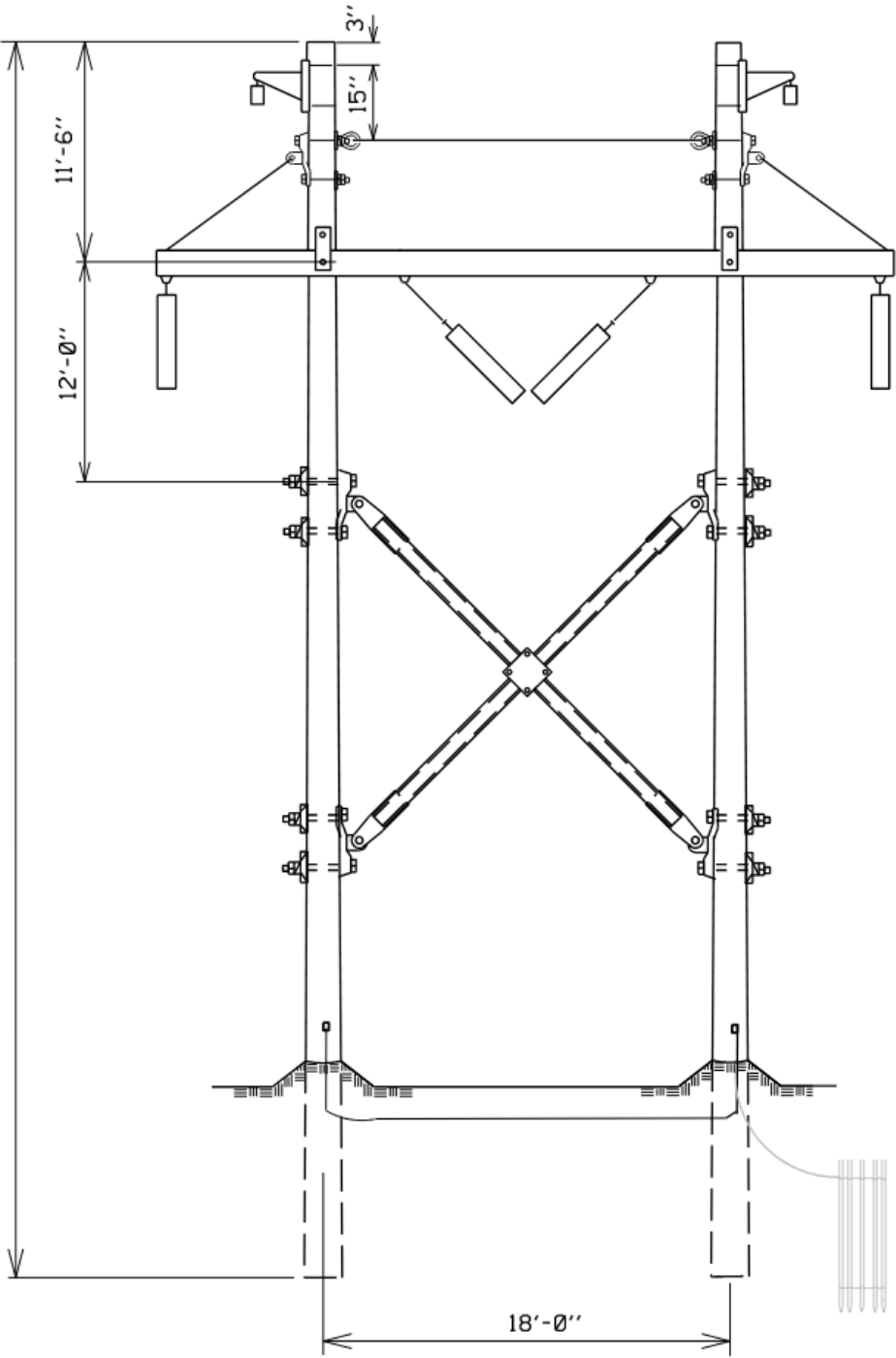
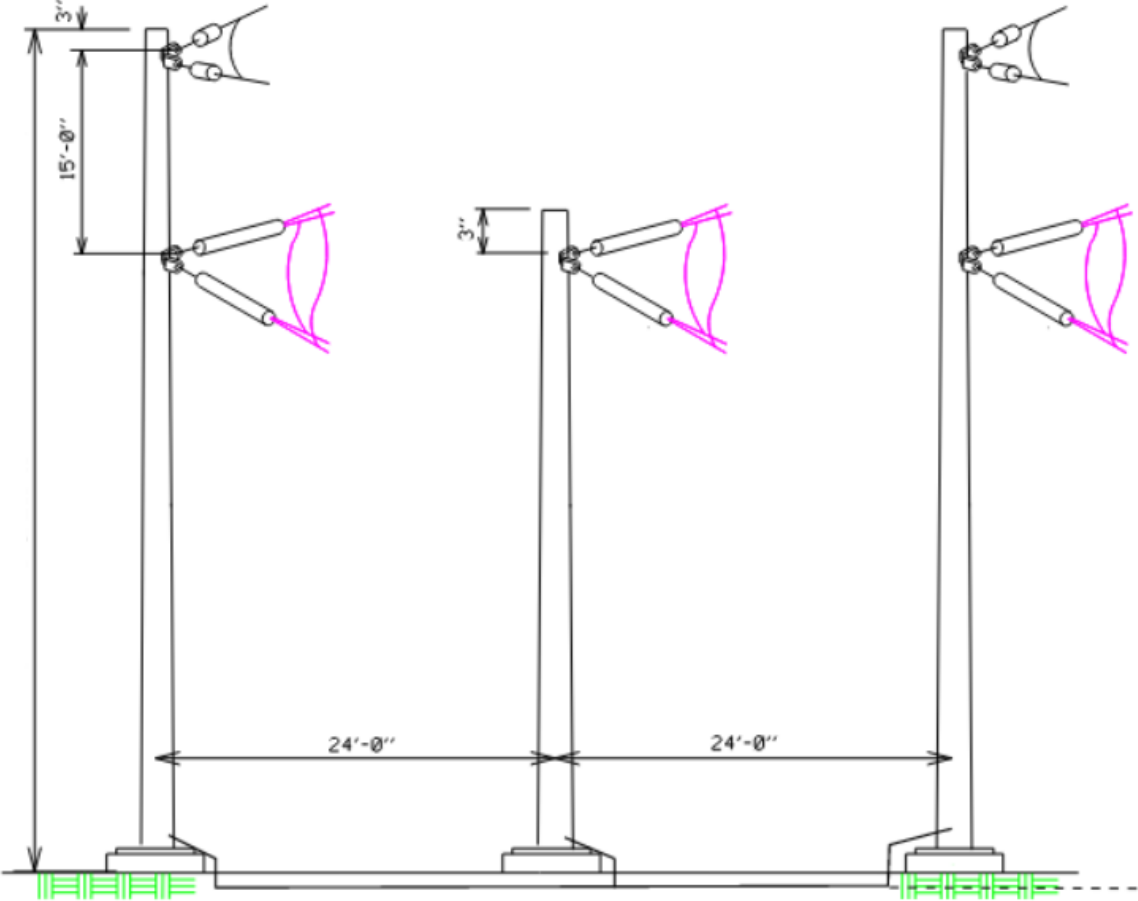

Figure 3 – Proposed Double Deadend Structure Configuration



Required Material Summary

Item	Qty
Direct Embed DOM Poles	8
Engineered Structures	2
Self-supporting Switch Structure	1
12,000-Ft OPGW Reels	2
12,000-Ft Conductor Reels	6