

***Generation Interconnection
Feasibility Study Report***

For

***PJM Generation Interconnection Request
Queue Position AB2-060***

***Chase City – Gary 115kV
54.4MW Capacity / 80MW Energy***

August / 2016

Introduction

This Feasibility Study has been prepared in accordance with the PJM Open Access Transmission Tariff, 36.2, as well as the Feasibility Study Agreement between the Interconnection Customer (IC), and PJM Interconnection, LLC (PJM), Transmission Provider (TP). The Interconnected Transmission Owner (ITO) is Virginia Electric and Power Company (VEPCO).

Preface

The intent of the Feasibility Study is to determine a plan, with high level estimated cost and construction time estimates, to connect the subject generation to the PJM network at a location specified by the IC. The IC may request the interconnection of generation as a capacity resource or as an energy-only resource. As a requirement for interconnection, the IC may be responsible for the cost of constructing: (1) Direct Connections, which are new facilities and/or facilities upgrades needed to connect the generator to the PJM network, and (2) Network Upgrades, which are facility additions, or upgrades to existing facilities, that are needed to maintain the reliability of the PJM system.

In some instances a generator interconnection may not be responsible for 100% of the identified network upgrade cost because other transmission network uses, e.g. another generation interconnection, may also contribute to the need for the same network reinforcement. The possibility of sharing the reinforcement costs with other projects may be identified in the Feasibility Study, but the actual allocation will be deferred until the Impact Study is performed.

The Feasibility Study estimates do not include the feasibility, cost, or time required to obtain property rights and permits for construction of the required facilities. The IC is responsible for the right of way, real estate, and construction permit issues. For properties currently owned by ITO, the costs may be included in the study.

General

The IC has proposed a solar generating facility located in Mecklenburg County, VA. The installed facilities will have a total capability of 80 MW with 54.4 MW of this output being recognized by PJM as capacity. The proposed in-service date for this project is 6/1/2017. **This study does not imply an ITO commitment to this in-service date.**

Point of Interconnection

AB2-060 will interconnect with the ITO transmission system at one of the following points of interconnection:

Option 1 will connect via a new three breaker ring bus switching station that connects on the Chase City – Gary – Crewe 115kV line #98.

Option 2 will connect via a new three breaker ring bus switching station that connects at the Chase City – Northview – Clubhouse 115kV.

Cost Summary

The AB2-060 project will be responsible for the following costs:

Description	Total Cost
Attachment Facilities	\$1,500,000
Direct Connection Network Upgrades	\$4,500,000
Non Direct Connection Network Upgrades	\$700,000
Total Costs	\$6,700,000

In addition, the AB2-060 project may be responsible for a contribution to the following costs:

Description	Total Cost
New System Upgrades	\$5,500,000
Previously Identified Upgrades	\$0
Total Costs	\$5,500,000

Cost allocations for these upgrades will be provided in the System Impact Study Report.

Attachment Facilities

Generation Substation: Install metering and associated protection equipment. Estimated Cost \$500,000.

Transmission: Construct approximately one span of 115 kV Attachment line between the generation substation and the existing Gary Tap 115 kV Substation. The estimated cost for this work is \$1,000,000.

The estimated total cost of the Attachment Facilities is \$1,500,000. It is estimated to take 18-24 months to complete this work. These costs do not include CIAC Tax Gross-up. The single line is shown below in Attachment 1.

Direct Connection Cost Estimate

Substation: Establish the new 115 kV AB2-060 Switching Substation (interconnection substation). The estimated cost of this work scope is \$4,500,000. It is estimated to take 24-36 months to complete this work.

Non-Direct Connection Cost Estimate

Transmission: Install transmission structure in-line with transmission line to allow the proposed interconnection switching station to be interconnected with the transmission system. Estimated cost is \$700,000 dollars and is estimated to take 24-30 months to complete.

Remote Terminal Work: During the Facilities Study, ITO's System Protection Engineering Department will review transmission line protection as well as anti-islanding required to accommodate the new generation and interconnection substation. System Protection Engineering will determine the minimal acceptable protection requirements to reliably interconnect the proposed generating facility with the transmission system. The review is based on maintaining system reliability by reviewing ITO's protection requirements with the known transmission system configuration which includes generating facilities in the area. This review may determine that transmission line protection and communication upgrades are required at remote substations.

Reinforcement: Upgrade the Clubhouse 230/115kV transformer. It is estimated to take 24-28 months to complete and it is estimated to cost \$5,500,000 to resolve this deficiency.

Interconnection Customer Requirements

ITO's Facility Connection Requirements as posted on PJM's website

<http://www.pjm.com/~media/planning/plan-standards/private-dominion/facility-connection-requirements1.ashx>

Voltage Ride Through Requirements - The Customer Facility shall be designed to remain in service (not trip) for voltages and times as specified for the Eastern Interconnection in Attachment 1 of NERC Reliability Standard PRC-024-1, and successor Reliability Standards, for both high and low voltage conditions, irrespective of generator size, subject to the permissive trip exceptions established in PRC-024-1 (and successor Reliability Standards).

Frequency Ride Through Requirements - The Customer Facility shall be designed to remain in service (not trip) for frequencies and times as specified in Attachment 2 of NERC Reliability Standard PRC-024-1, and successor Reliability Standards, for both high and low frequency condition, irrespective of generator size, subject to the permissive trip exceptions established in PRC-024-1 (and successor Reliability Standards).

Reactive Power - The Generation Interconnection Customer shall design its non-synchronous Customer Facility with the ability to maintain a power factor of at least 0.95 leading to 0.95 lagging measured at the generator's terminals.

Revenue Metering and SCADA Requirements

PJM Requirements

The IC will be required to install equipment necessary to provide Revenue Metering (KWH, KVARH) and real time data (KW, KVAR) for IC's generating Resource. See PJM Manuals M-01 and M-14D, and PJM Tariff Sections 24.1 and 24.2.

Option One

Network Impacts

The Queue Project AB2-060 was evaluated as a 80.0 MW (Capacity 54.4 MW) injection at the Gary tap 115kV substation in the DVP area. Project AB2-060 was evaluated for compliance with applicable reliability planning criteria (PJM, NERC, NERC Regional Reliability Councils, and Transmission Owners). Project AB2-060 was studied with a commercial probability of 53%. Potential network impacts were as follows:

Contingency Descriptions

The following contingencies resulted in overloads:

Contingency Name	Description
T122C	CONTINGENCY 'T122C' /* CAROLINA OPEN BUS 314559 /* CAROLINA 115KV BUS OPEN BUS 315126 /* ROANOKE RAPIDS GEN 1 AND 2 OPEN BUS 315128 /* ROANOKE RAPIDS GEN 3 AND 4 OPEN BRANCH FROM BUS 314559 TO BUS 314561 CKT 1 /* TX. #4 END
2202_A	CONTINGENCY '2202_A' /* CAROLINA OPEN BRANCH FROM BUS 314559 TO BUS 314571 CKT 1 /* LINE 22 OPEN BRANCH FROM BUS 314571 TO BUS 314702 CKT 1 /* LINE 22 OPEN BRANCH FROM BUS 314559 TO BUS 314259 CKT Z1 /* LINE 56 OPEN BRANCH FROM BUS 314559 TO BUS 921751 CKT 1 /* LINE 54 AA2-053 TAP OPEN BRANCH FROM BUS 314559 TO BUS 314600 CKT 1 /* LINE 130 OPEN BRANCH FROM BUS 314559 TO BUS 314561 CKT 1 /* TX. #4 DECREASE BUS 314559 LOAD BY 100 PERCENT /* REMOVE ALL LOAD AT CAROLINA END

Contingency Name	Description
T132_A	CONTINGENCY 'T132_A' /* CAROLINA OPEN BRANCH FROM BUS 314559 TO BUS 314259 CKT Z1 /* LINE 56 OPEN BRANCH FROM BUS 314559 TO BUS 921751 CKT 1 /* LINE 54 AA2-053 TAP OPEN BRANCH FROM BUS 314559 TO BUS 314571 CKT 1 /* LINE 22 OPEN BRANCH FROM BUS 314559 TO BUS 314600 CKT 1 /* LINE 130 OPEN BRANCH FROM BUS 314559 TO BUS 314561 CKT 1 /* TX. #4 DECREASE BUS 314559 LOAD BY 100 PERCENT /* REMOVE ALL LOAD AT CAROLINA END
5602_A	CONTINGENCY '5602_A' /* CAROLINA OPEN BRANCH FROM BUS 314559 TO BUS 314259 CKT Z1 /* LINE 56 OPEN BRANCH FROM BUS 314259 TO BUS 921161 CKT 1 /* LINE 56 AA1-063A TAP OPEN BRANCH FROM BUS 314559 TO BUS 921751 CKT 1 /* LINE 54 AA2-053 TAP OPEN BRANCH FROM BUS 314559 TO BUS 314571 CKT 1 /* LINE 22 OPEN BRANCH FROM BUS 314559 TO BUS 314600 CKT 1 /* LINE 130 OPEN BRANCH FROM BUS 314559 TO BUS 314561 CKT 1 /* TX. #4 DECREASE BUS 314559 LOAD BY 100 PERCENT /* REMOVE ALL LOAD AT CAROLINA END

Contingency Name	Description
5402_A	CONTINGENCY '5402_A' /* CAROLINA OPEN BRANCH FROM BUS 314559 TO BUS 921751 CKT 1 /* LINE 54 AA2-053 TAP OPEN BRANCH FROM BUS 314559 TO BUS 314571 CKT 1 /* LINE 22 OPEN BRANCH FROM BUS 314559 TO BUS 314259 CKT Z1 /* LINE 56 OPEN BRANCH FROM BUS 314559 TO BUS 314600 CKT 1 /* LINE 130 OPEN BRANCH FROM BUS 314559 TO BUS 314561 CKT 1 /* TX. #4 DECREASE BUS 314559 LOAD BY 100 PERCENT /* REMOVE ALL LOAD AT CAROLINA END
LN 511	CONTINGENCY 'LN 511' OPEN BRANCH FROM BUS 314902 TO BUS 314936 CKT 1 /* 8CARSON 500.00 - 8RAWLINGS 500.00 END

Summer Peak Analysis - 2020

Generator Deliverability

(Single or N-1 contingencies for the Capacity portion only of the interconnection)

None

Multiple Facility Contingency

(Double Circuit Tower Line contingencies were studied for the full energy output. The contingencies of Line with Failed Breaker and Bus Fault will be performed for the Impact Study.)

#	Contingency		Affected Area	Facility Description	Bus			Power Flow	Loading %		Rating		MW Contribution	Ref
	Type	Name			From	To	Cir.		Initial	Final	Type	MVA		
1	LFFB	T122C	DVP - DVP	6CLUBHSE 230/115 kV transformer	314562	314563	1	DC	54.16	59.58	ER	194	10.52	1
2	LFFB	2202_A	DVP - DVP	6CLUBHSE 230/115 kV transformer	314562	314563	1	DC	52.98	58.09	ER	194	9.93	
3	LFFB	T132_A	DVP - DVP	6CLUBHSE 230/115 kV transformer	314562	314563	1	DC	51.95	57.06	ER	194	9.93	
4	LFFB	5602_A	DVP - DVP	6CLUBHSE 230/115 kV transformer	314562	314563	1	DC	51.9	57.01	ER	194	9.93	
5	LFFB	5402_A	DVP - DVP	6CLUBHSE 230/115 kV transformer	314562	314563	1	DC	51.75	56.86	ER	194	9.93	

Short Circuit

(Summary of impacted circuit breakers)

New circuit breakers found to be over-duty:

None

Contributions to previously identified circuit breakers found to be over-duty:

None

Contribution to Previously Identified Overloads

(This project contributes to the following contingency overloads, i.e. "Network Impacts", identified for earlier generation or transmission interconnection projects in the PJM Queue)

None

Steady-State Voltage Requirements

(Summary of the VAR requirements based upon the results of the steady-state voltage studies)

To be determined during Impact Study.

Stability and Reactive Power Requirement for Low Voltage Ride Through

(Summary of the VAR requirements based upon the results of the dynamic studies)

To be determined during Impact Study.

New System Reinforcements

(Upgrades required to mitigate reliability criteria violations, i.e. Network Impacts, initially caused by the addition of this project generation)

Violation #	Overloaded Facility	Upgrade Description	Network Upgrade Number	Upgrade Cost
# 1 - 5	6CLUBHSE 230/115 kV transformer	Upgrade the Clubhouse 230/115kV transformer	Pending	\$5,500,000
Total New Network Upgrades				\$5,500,000

Contribution to Previously Identified System Reinforcements

(Overloads initially caused by prior Queue positions with additional contribution to overloading by this project. This project may have a % allocation cost responsibility which will be calculated and reported for the Impact Study)

None

Potential Congestion due to Local Energy Deliverability

PJM also studied the delivery of the energy portion of this interconnection request. Any problems identified below are likely to result in operational restrictions to the project under study. The IC can proceed with network upgrades to eliminate the operational restriction at their discretion by submitting a Merchant Transmission Interconnection request.

Note: Only the most severely overloaded conditions are listed below. There is no guarantee of full delivery of energy for this project by fixing only the conditions listed in this section. With a Transmission Interconnection Request, a subsequent analysis will be performed which shall study all overload conditions associated with the overloaded element(s) identified.

#	Contingency		Affected Area	Facility Description	Bus			Power Flow	Loading %		Rating		MW Contribution
	Type	Name			From	To	Circuit		Initial	Final	Type	MVA	
	N-1	LN 511	DVP - DVP	8ROGERS RD-8CARSON 500 kV line	314940	314902	1	DC	99.93	100.09	ER	3424	12.2

Light Load Analysis

Light Load Studies to be conducted during later study phases (as required by PJM Manual 14B).

ITO Analysis

ITO assessed the impact of the proposed Queue Project #AB2-060 interconnection of an 80 MW Energy (54.4 MW Capacity) injection into the ITO's Transmission System, for compliance with NERC Reliability Criteria on ITO's Transmission System. The system was assessed using the summer 2020 RTEP case provided to ITO by PJM. When performing a generation analysis, ITO's main analysis will be load flow study results under single contingency (both normal and stressed system conditions). ITO Criteria considers a transmission facility overloaded if it exceeds 94% of its emergency rating under normal and stressed system conditions. A full listing of ITO's Planning Criteria and interconnection requirements can be found in the ITO's Facility Connection Requirements which are publicly available at: <http://www.dom.com>.

The results of these studies evaluate the system under a limited set of operating conditions and do not guarantee the full delivery of the capacity and associated energy of this proposed generation facility under all operating conditions. NERC Planning and Operating Reliability Criteria allow for the re-dispatch of generating units to resolve projected and actual deficiencies in real time and planning studies. Specifically NERC Category C Contingency Conditions (Bus Fault, Tower Line, N-1-1, and Stuck Breaker scenarios) allow for re-dispatch of generating units to resolve potential reliability deficiencies. For ITO’s Planning Criteria the re-dispatch of generating units for these contingency conditions is allowed as long as the projected loading does not exceed 100% of a facility Load Dump Rating.

As part of its generation impact analysis, the ITO routinely evaluates the impact that a proposed new generation resource will have under maximum generation conditions, stress system conditions and import/export system conditions (greater than 20 MW). The results of these studies are discussed in more detail below.

Category B Analysis (Single Contingency):

1. System Normal – No deficiencies identified
2. Critical System Condition (No Surry 230 kV Unit) – No deficiencies identified.

Category C Analysis: (Multiple Facility Analysis)

1. Bus Fault - No deficiencies identified
2. Line Stuck Breaker - No deficiencies identified
3. Tower Line – No deficiencies identified

Import/Export Analysis (Single Contingency) are tabulated in Table A and B below.

Table A: Import Study Results

Import Study Results			
Area	Summer 2020	Summer 2020 with AB2-060	Limiting Element
AEP	2000+	2000+	None
APS	2000+	2000+	None
CPL	2000+	2000+	None
PJM	2000+	2000+	None

Table B: Export Study Results

Export Study Results			
Area	Summer 2020	Summer 2020 with AB2-060	Limiting Element
AEP	2000+	2000+	None
APS	2000+	2000+	None
CPL	2000+	2000+	None
PJM	2000+	2000+	None

ITO’s Planning Criteria indicates a need to have approximately 2000 MW of import and export capability. The results of these import and export studies indicate that the proposed interconnection will not impact ITO’s import or export capability.

Affected System Analysis & Mitigation

Duke, Progress & TVA Impacts:

Duke Carolina, Progress, & TVA Impacts to be determined during later study phases (as applicable).

Option Two

Network Impacts

The Queue Project AB2-060 was evaluated as a 80.0 MW (Capacity 54.4 MW) injection at the Northview 115kV substation in the ITO area. Project AB2-060 was evaluated for compliance with applicable reliability planning criteria (PJM, NERC, NERC Regional Reliability Councils, and Transmission Owners). Project AB2-060 was studied with a commercial probability of 53%. Potential network impacts were as follows:

Contingency Descriptions

The following contingencies resulted in overloads:

Contingency Name	Description
239T2141	CONTINGENCY '239T2141' /* LAKEVIEW OPEN BRANCH FROM BUS 314583 TO BUS 314579 CKT 1 /* 239 OPEN BRANCH FROM BUS 314579 TO BUS 314605 CKT 1 /* 2057 OPEN BRANCH FROM BUS 314583 TO BUS 314561 CKT 1 /* 2141 END
LN 208-259	CONTINGENCY 'LN 208-259' OPEN BRANCH FROM BUS 314286 TO BUS 314309 CKT 1 /* 6CHSTF A 230.00 - 6IRON208 230.00 OPEN BRANCH FROM BUS 314309 TO BUS 314338 CKT 1 /* 6IRON208 230.00 - 6SOUWEST 230.00 OPEN BUS 314309 /* ISLAND OPEN BRANCH FROM BUS 314276 TO BUS 314287 CKT 1 /* 6BASIN 230.00 - 6CHSTF B 230.00 END
LN 563	CONTINGENCY 'LN 563' OPEN BRANCH FROM BUS 314902 TO BUS 314914 CKT 1 /* 8CARSON 500.00 - 8MDLTHAN 500.00 END

Summer Peak Analysis - 2020

Generator Deliverability

(Single or N-1 contingencies for the Capacity portion only of the interconnection)

None

Multiple Facility Contingency

(Double Circuit Tower Line contingencies were studied for the full energy output. The contingencies of Line with Failed Breaker and Bus Fault will be performed for the Impact Study.)

#	Contingency		Affected Area	Facility Description	Bus		Cir.	Power Flow	Loading %		Rating		MW Contribution	Ref
	Type	Name			From	To			Initial	Final	Type	MVA		
1	LFFB	239T2141	DVP - DVP	6CLUBHSE-6SAPONY 230 kV line	314563	314435	1	DC	57.15	60.24	ER	637	19.66	2

Short Circuit

(Summary of impacted circuit breakers)

New circuit breakers found to be over-duty:

None

Contributions to previously identified circuit breakers found to be over-duty:

None

Contribution to Previously Identified Overloads

(This project contributes to the following contingency overloads, i.e. "Network Impacts", identified for earlier generation or transmission interconnection projects in the PJM Queue)

#	Contingency	Affected	Facility Description	Bus	Cir.	Power	Loading %	Rating	MW	Ref
---	-------------	----------	----------------------	-----	------	-------	-----------	--------	----	-----

Type	Name	Area	From	To	Flow	Initial	Final	Type	MVA	Contribution				
2	DCTL	LN 208-259	DVP - DVP	6CHARCTY-6LAKESD 230 kV line	314225	314227	1	DC	119.53	119.99	ER	399	4.1	3
3	DCTL	LN 208-259	DVP - DVP	6MESSER-6CHARCTY 230 kV line	314228	314225	1	DC	133.04	133.5	ER	399	4.1	4
4	DCTL	LN 208-259	DVP - DVP	6CHSTF B-6MESSER 230 kV line	314287	314228	1	DC	133.21	133.68	ER	399	4.1	5

Steady-State Voltage Requirements

(Summary of the VAR requirements based upon the results of the steady-state voltage studies)

To be determined during Impact Study.

Stability and Reactive Power Requirement for Low Voltage Ride Through

(Summary of the VAR requirements based upon the results of the dynamic studies)

To be determined during Impact Study.

Potential Congestion due to Local Energy Deliverability

PJM also studied the delivery of the energy portion of this interconnection request. Any problems identified below are likely to result in operational restrictions to the project under study. The IC can proceed with network upgrades to eliminate the operational restriction at their discretion by submitting a Merchant Transmission Interconnection request.

Note: Only the most severely overloaded conditions are listed below. There is no guarantee of full delivery of energy for this project by fixing only the conditions listed in this section. With a Transmission Interconnection Request, a subsequent analysis will be performed which shall study all overload conditions associated with the overloaded element(s) identified.

#	Contingency		Affected Area	Facility Description	Bus		Circuit	Power Flow	Loading %		Rating		MW Contribution
	Type	Name			From	To			Initial	Final	Type	MVA	

#	Contingency		Affected Area	Facility Description	Bus			Power Flow	Loading %		Rating		MW Contribution
	Type	Name			From	To	Circuit		Initial	Final	Type	MVA	
5	N-1	LN 563	DVP - DVP	6CHSTF B-6BASIN 230 kV line	314287	314276	1	DC	108.98	109.45	ER	470	4.87

Light Load Analysis

Light Load Studies to be conducted during later study phases (as required by PJM Manual 14B).

ITO Analysis

ITO assessed the impact of the proposed Queue Project #AB2-060 interconnection of an 80 MW Energy (54.4 MW Capacity) injection into the ITO's Transmission System, for compliance with NERC Reliability Criteria on ITO's Transmission System. The system was assessed using the summer 2020 RTEP case provided to ITO by PJM. When performing a generation analysis, ITO's main analysis will be load flow study results under single contingency (both normal and stressed system conditions). ITO Criteria considers a transmission facility overloaded if it exceeds 94% of its emergency rating under normal and stressed system conditions. A full listing of ITO's Planning Criteria and interconnection requirements can be found in the ITO's Facility Connection Requirements which are publicly available at: <http://www.dom.com>.

The results of these studies evaluate the system under a limited set of operating conditions and do not guarantee the full delivery of the capacity and associated energy of this proposed generation facility under all operating conditions. NERC Planning and Operating Reliability Criteria allow for the re-dispatch of generating units to resolve projected and actual deficiencies in real time and planning studies. Specifically NERC Category C Contingency Conditions (Bus Fault, Tower Line, N-1-1, and Stuck Breaker scenarios) allow for re-dispatch of generating units to resolve potential reliability deficiencies. For ITO's Planning Criteria the re-dispatch of generating units for these contingency conditions is allowed as long as the projected loading does not exceed 100% of a facility Load Dump Rating.

As part of its generation impact analysis, the ITO routinely evaluates the impact that a proposed new generation resource will have under maximum generation conditions, stress system conditions and import/export system conditions (greater than 20 MW). The results of these studies are discussed in more detail below.

Category B Analysis (Single Contingency):

System Normal – No deficiencies identified

Critical System Condition (No Surry 230 kV Unit) – No deficiencies identified.

Category C Analysis: (Multiple Facility Analysis)

Bus Fault - No deficiencies identified

Line Stuck Breaker - No deficiencies identified

Tower Line – No deficiencies identified

Import/Export Analysis (Single Contingency) are tabulated in Table A and B below.

Table A: Import Study Results

Import Study Results			
Area	Summer 2020	Summer 2020 with AB2-060	Limiting Element
AEP	2000+	2000+	None
APS	2000+	2000+	None
CPL	2000+	2000+	None
PJM	2000+	2000+	None

Table B: Export Study Results

Export Study Results			
Area	Summer 2020	Summer 2020 with AB2-060	Limiting Element
AEP	2000+	2000+	None
APS	2000+	2000+	None
CPL	2000+	2000+	None
PJM	2000+	2000+	None

ITO's Planning Criteria indicates a need to have approximately 2000 MW of import and export capability. The results of these import and export studies indicate that the proposed interconnection will not impact ITO's import or export capability.

Affected System Analysis & Mitigation

Duke, Progress & TVA Impacts:

Duke Carolina, Progress, & TVA Impacts to be determined during later study phases (as applicable).

Attachment 1

System Configuration

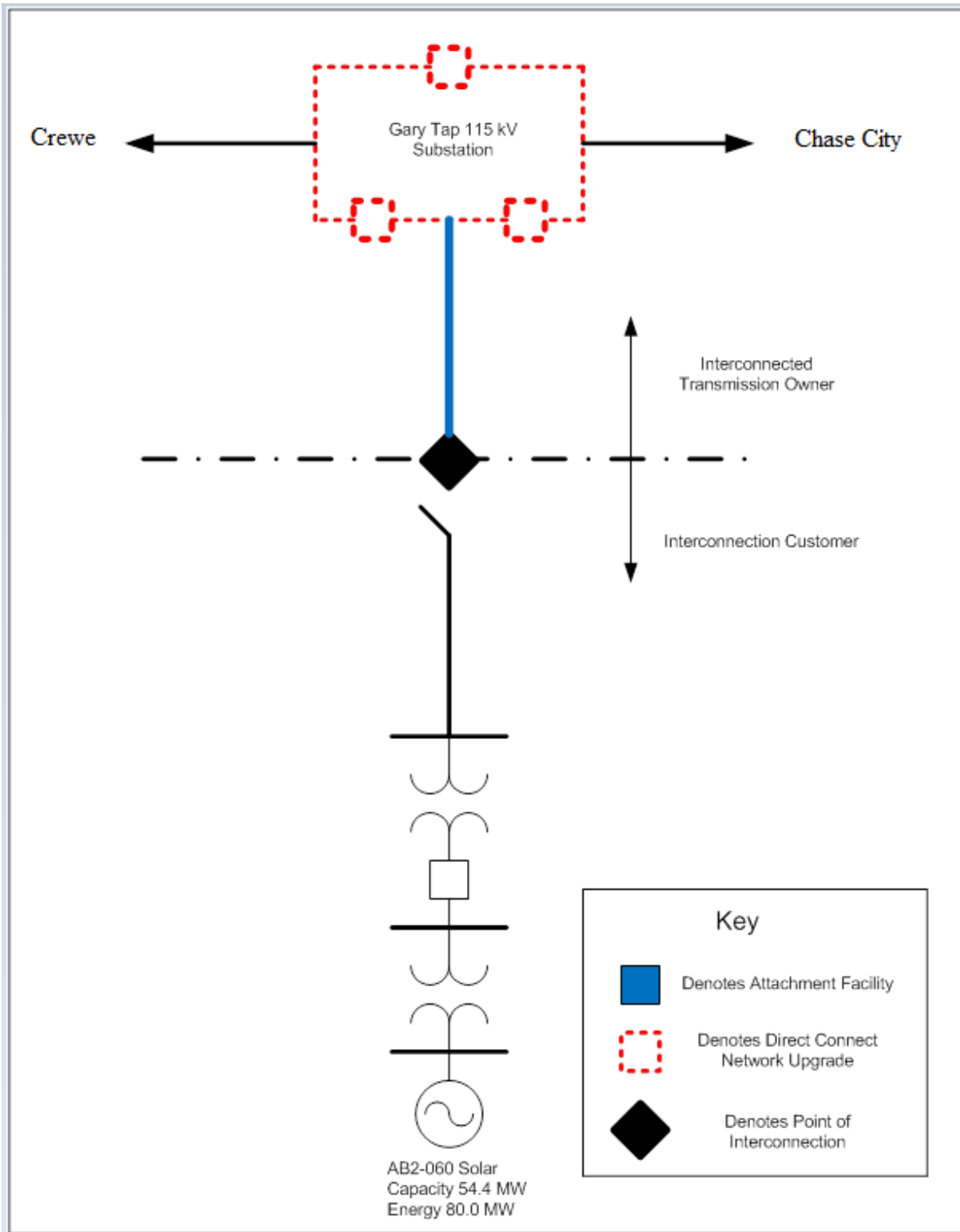

Flowgate Appendices – Option 1

Appendices

The following appendices contain additional information about each flowgate presented in the body of the report. For each appendix, a description of the flowgate and its contingency was included for convenience. However, the intent of the appendix section is to provide more information on which projects/generators have contributions to the flowgate in question. Although this information is not used "as is" for cost allocation purposes, it can be used to gauge other generators impact. When a flowgate is identified in multiple analysis the appendix is presented for only the analysis with the greatest overload.

It should be noted the generator contributions presented in the appendices sections are full contributions, whereas in the body of the report, those contributions take into consideration the commercial probability of each project.

Appendix 1

(DVP - DVP) The 6CLUBHSE 230/115 kV transformer (from bus 314562 to bus 314563 ckt 1) loads from 54.16% to 59.58% (**DC power flow**) of its emergency rating (194 MVA) for the line fault with failed breaker contingency outage of 'T122C'. This project contributes approximately 10.52 MW to the thermal violation.

CONTINGENCY 'T122C'

OPEN BUS 314559

OPEN BUS 315126

OPEN BUS 315128

OPEN BRANCH FROM BUS 314559 TO BUS 314561 CKT 1

END

/* CAROLINA

/* CAROLINA 115KV BUS

/* ROANOKE RAPIDS GEN 1 AND 2

/* ROANOKE RAPIDS GEN 3 AND 4

/* TX. #4

<i>Bus Number</i>	<i>Bus Name</i>	<i>Full Contribution</i>
315159	1KERR 2	1.27
315163	1KERR 6	1.25
315164	1KERR 7	1.25
314704	3LAWRENC	1.43
922472	AA2-169 C	1.68
922473	AA2-169 E	0.77
923572	AB1-173 C OP	10.72
923573	AB1-173 E OP	5.
923582	AB1-173AC OP	10.72
923583	AB1-173AE OP	5.
923911	AB2-031 C OP	10.64
923912	AB2-031 E OP	5.24
923991	AB2-040 C OP	36.2
923992	AB2-040 E OP	27.31
924021	AB2-043 C OP	3.15
924022	AB2-043 E OP	5.16
924161	AB2-060 C OP	7.15
924162	AB2-060 E OP	3.37
924251	AB2-069 C OP	2.46
924252	AB2-069 E OP	3.88
924301	AB2-077 C OP	1.93
924302	AB2-077 E OP	1.29
924311	AB2-078 C OP	1.93
924312	AB2-078 E OP	1.29
924321	AB2-079 C OP	1.93
924322	AB2-079 E OP	1.29
924401	AB2-089 C	1.61
924402	AB2-089 E	0.83
924411	AB2-090 C	3.96

924412	AB2-090 E	2.03
924931	AB2-147 C	11.39
924932	AB2-147 E	18.59
924951	AB2-150 C OP	11.39
924952	AB2-150 E OP	18.59
925171	AB2-174 C OP	33.34
925172	AB2-174 E OP	30.17
925221	AB2-176 C	1.63
925222	AB2-176 E	0.7

Appendix 2

(DVP - DVP) The 6CLUBHSE-6SAPONY 230 kV line (from bus 314563 to bus 314435 ckt 1) loads from 57.15% to 60.24% (**DC power flow**) of its emergency rating (637 MVA) for the line fault with failed breaker contingency outage of '239T2141'. This project contributes approximately 19.66 MW to the thermal violation.

CONTINGENCY '239T2141'

/* LAKEVIEW

OPEN BRANCH FROM BUS 314583 TO BUS 314579 CKT 1 /* 239
 OPEN BRANCH FROM BUS 314579 TO BUS 314605 CKT 1 /* 2057
 OPEN BRANCH FROM BUS 314583 TO BUS 314561 CKT 1 /* 2141
 END

<i>Bus Number</i>	<i>Bus Name</i>	<i>Full Contribution</i>
315139	1GASTONA	16.92
315141	1GASTONB	16.92
315159	1KERR 2	1.19
315164	1KERR 7	1.17
315126	1ROARAP2	1.59
315128	1ROARAP4	1.53
314704	3LAWRENC	1.
921162	AA1-063AC	6.84
921163	AA1-063AE	3.22
921752	AA2-053 C	7.37
921753	AA2-053 E	3.16
922032	AA2-105 C	2.07
922033	AA2-105 E	0.97
922072	AA2-113 C	2.07
922073	AA2-113 E	0.97
922472	AA2-169 C	1.83
922473	AA2-169 E	0.84
922512	AA2-174 C	0.34
922513	AA2-174 E	0.37
923262	AB1-132 C OP	65.96
923263	AB1-132 E OP	28.27
923572	AB1-173 C OP	5.09
923573	AB1-173 E OP	2.38
923582	AB1-173AC OP	5.09
923583	AB1-173AE OP	2.38
923911	AB2-031 C OP	10.52
923912	AB2-031 E OP	5.18
923991	AB2-040 C OP	35.8
923992	AB2-040 E OP	27.01
924161	AB2-060 C OP	13.37

924162	AB2-060 E OP	6.29
924251	AB2-069 C OP	2.24
924252	AB2-069 E OP	3.54
924401	AB2-089 C	1.61
924402	AB2-089 E	0.83
924411	AB2-090 C	3.12
924412	AB2-090 E	1.6
924511	AB2-100 C	52.61
924512	AB2-100 E	25.91
924761	AB2-128 C	45.07
924762	AB2-128 E	17.75
924931	AB2-147 C	7.84
924932	AB2-147 E	12.79
924951	AB2-150 C OP	11.93
924952	AB2-150 E OP	19.47
925171	AB2-174 C OP	32.98
925172	AB2-174 E OP	29.84
925221	AB2-176 C	1.29
925222	AB2-176 E	0.55

Appendix 3

(DVP - DVP) The 6CHARCTY-6LAKESD 230 kV line (from bus 314225 to bus 314227 ckt 1) loads from 119.53% to 119.99% (**DC power flow**) of its emergency rating (399 MVA) for the tower line contingency outage of 'LN 208-259'. This project contributes approximately 4.1 MW to the thermal violation.

CONTINGENCY 'LN 208-259'

OPEN BRANCH FROM BUS 314286 TO BUS 314309 CKT 1 /* 6CHSTF A
230.00 - 6IRON208 230.00

OPEN BRANCH FROM BUS 314309 TO BUS 314338 CKT 1 /* 6IRON208
230.00 - 6SOUWEST 230.00

OPEN BUS 314309 /* ISLAND

OPEN BRANCH FROM BUS 314276 TO BUS 314287 CKT 1 /* 6BASIN 230.00 -
6CHSTF B 230.00

END

<i>Bus Number</i>	<i>Bus Name</i>	<i>Full Contribution</i>
315065	1CHESTF6	37.23
315077	1HOPHCF1	2.16
315078	1HOPHCF2	2.16
315079	1HOPHCF3	2.16
315080	1HOPHCF4	3.27
315076	1HOPPOLC	1.84
315073	1STONECA	5.67
314784	1WEYRHSB	0.66
314314	3LOCKS	1.04
314539	3UNCAMP	0.86
314541	3WATKINS	0.25
314229	6MT R221	-0.33
292791	U1-032 E	2.95
900672	V4-068 E	0.11
901082	W1-029E	13.49
902241	W2-022 C OPI	0.49
902242	W2-022 E OPI	3.31
903520	W3-066 C1OPI	0.98
903531	W3-066 C2OPI	0.98
903522	W3-066 E1OPI	6.54
903532	W3-066 E2OPI	6.54
907092	X1-038 E	2.15
913392	Y1-086 E	0.63
914231	Y2-077	0.87

916042	Z1-036 E	13.59
916192	Z1-068 E	0.53
917122	Z2-027 E	0.31
917332	Z2-043 E	0.34
917342	Z2-044 E	0.18
917592	Z2-099 E	0.16
921092	AA1-049 C	0.68
921093	AA1-049 E	0.32
921162	AA1-063AC	3.19
921163	AA1-063AE	1.51
918512	AA1-065 E OP	1.48
918562	AA1-072 E	0.06
921532	AA1-132 C	2.1
921533	AA1-132 E	0.9
921552	AA1-134 C	2.89
921553	AA1-134 E	1.24
921562	AA1-135 C	2.95
921563	AA1-135 E	1.26
921572	AA1-138 C	3.
921573	AA1-138 E	1.29
921752	AA2-053 C	3.26
921753	AA2-053 E	1.4
921762	AA2-057 C	2.35
921763	AA2-057 E	1.17
921772	AA2-059 C	0.72
921773	AA2-059 E	0.33
921862	AA2-068 C	0.76
921863	AA2-068 E	0.35
920022	AA2-086 E	0.09
921982	AA2-088 C	2.33
921983	AA2-088 E	3.81
922032	AA2-105 C	0.85
922033	AA2-105 E	0.4
922072	AA2-113 C	0.85
922073	AA2-113 E	0.4
922442	AA2-165 C	0.32
922443	AA2-165 E	0.15
922472	AA2-169 C	0.71
922473	AA2-169 E	0.33
922512	AA2-174 C	0.15
922513	AA2-174 E	0.16
922522	AA2-177 C	6.39
922523	AA2-177 E	2.74
922532	AA2-178 C	2.96
922533	AA2-178 E	1.27

922602	<i>ABI-013 C</i>	0.89
922603	<i>ABI-013 E</i>	5.98
922722	<i>ABI-053 C</i>	0.44
922723	<i>ABI-053 E</i>	0.25
922732	<i>ABI-054 C</i>	2.47
922733	<i>ABI-054 E</i>	1.22
922882	<i>ABI-077 C</i>	1.01
922883	<i>ABI-077 E</i>	6.75
923262	<i>ABI-132 C OP</i>	5.97
923263	<i>ABI-132 E OP</i>	2.56
923572	<i>ABI-173 C OP</i>	0.99
923573	<i>ABI-173 E OP</i>	0.46
923582	<i>ABI-173AC OP</i>	0.99
923583	<i>ABI-173AE OP</i>	0.46
923801	<i>AB2-015 C OP</i>	3.8
923802	<i>AB2-015 E OP</i>	2.76
923831	<i>AB2-022 C</i>	0.66
923832	<i>AB2-022 E</i>	0.35
923851	<i>AB2-025 C</i>	1.62
923852	<i>AB2-025 E</i>	0.73
923911	<i>AB2-031 C OP</i>	1.11
923912	<i>AB2-031 E OP</i>	0.55
923981	<i>AB2-039 C OP</i>	5.76
923982	<i>AB2-039 E OP</i>	4.71
923991	<i>AB2-040 C OP</i>	3.79
923992	<i>AB2-040 E OP</i>	2.86
924011	<i>AB2-042 C OP</i>	5.26
924012	<i>AB2-042 E OP</i>	4.19
924071	<i>AB2-051 C OP</i>	39.
924072	<i>AB2-051 E OP</i>	6.06
924161	<i>AB2-060 C OP</i>	2.79
924162	<i>AB2-060 E OP</i>	1.31
924381	<i>AB2-087 C</i>	0.19
924382	<i>AB2-087 E</i>	0.09
924501	<i>AB2-099 C</i>	0.2
924502	<i>AB2-099 E</i>	0.09
924511	<i>AB2-100 C</i>	5.58
924512	<i>AB2-100 E</i>	2.75
924761	<i>AB2-128 C</i>	4.78
924762	<i>AB2-128 E</i>	1.88
924811	<i>AB2-134 C OP</i>	8.19
924812	<i>AB2-134 E OP</i>	10.95
924931	<i>AB2-147 C</i>	1.18
924932	<i>AB2-147 E</i>	1.92
924941	<i>AB2-149 C OP</i>	1.51

924942	AB2-149 E OP	2.47
924951	AB2-150 C OP	1.45
924952	AB2-150 E OP	2.37
924961	AB2-152	15.85
925051	AB2-160 C OP	4.05
925052	AB2-160 E OP	6.61
925061	AB2-161 C OP	2.37
925062	AB2-161 E OP	3.87
925121	AB2-169 C OP	2.01
925122	AB2-169 E OP	1.8
925141	AB2-171 C OP	1.75
925142	AB2-171 E OP	2.85
925171	AB2-174 C OP	3.49
925172	AB2-174 E OP	3.16
925281	AB2-186 C	0.18
925282	AB2-186 E	0.08
925291	AB2-188 C OP	0.73
925292	AB2-188 E OP	0.33
925331	AB2-190 C	14.6
925332	AB2-190 E	3.65

Appendix 4

(DVP - DVP) The 6MESSER-6CHARCTY 230 kV line (from bus 314228 to bus 314225 ckt 1) loads from 133.04% to 133.5% (**DC power flow**) of its emergency rating (399 MVA) for the tower line contingency outage of 'LN 208-259'. This project contributes approximately 4.1 MW to the thermal violation.

CONTINGENCY 'LN 208-259'

OPEN BRANCH FROM BUS 314286 TO BUS 314309 CKT 1 /* 6CHSTF A
230.00 - 6IRON208 230.00

OPEN BRANCH FROM BUS 314309 TO BUS 314338 CKT 1 /* 6IRON208
230.00 - 6SOUWEST 230.00

OPEN BUS 314309 /* ISLAND

OPEN BRANCH FROM BUS 314276 TO BUS 314287 CKT 1 /* 6BASIN 230.00 -
6CHSTF B 230.00

END

<i>Bus Number</i>	<i>Bus Name</i>	<i>Full Contribution</i>
315065	1CHESTF6	37.23
315077	1HOPHCF1	2.16
315078	1HOPHCF2	2.16
315079	1HOPHCF3	2.16
315080	1HOPHCF4	3.27
315076	1HOPPOLC	1.84
315073	1STONECA	5.67
314784	1WEYRHSB	0.66
314314	3LOCKS	1.04
314539	3UNCAMP	0.86
314541	3WATKINS	0.25
314229	6MT R221	-0.33
292791	U1-032 E	2.95
900672	V4-068 E	0.11
901082	W1-029E	13.49
902241	W2-022 C OPI	0.49
902242	W2-022 E OPI	3.31
903520	W3-066 C1OPI	0.98
903531	W3-066 C2OPI	0.98
903522	W3-066 E1OPI	6.54
903532	W3-066 E2OPI	6.54
907092	X1-038 E	2.15
913392	Y1-086 E	0.63
914231	Y2-077	0.87

916042	Z1-036 E	13.59
916192	Z1-068 E	0.53
917122	Z2-027 E	0.31
917332	Z2-043 E	0.34
917342	Z2-044 E	0.18
917592	Z2-099 E	0.16
921092	AA1-049 C	0.68
921093	AA1-049 E	0.32
921162	AA1-063AC	3.19
921163	AA1-063AE	1.51
918512	AA1-065 E OP	1.48
918562	AA1-072 E	0.06
921532	AA1-132 C	2.1
921533	AA1-132 E	0.9
921552	AA1-134 C	2.89
921553	AA1-134 E	1.24
921562	AA1-135 C	2.95
921563	AA1-135 E	1.26
921572	AA1-138 C	3.
921573	AA1-138 E	1.29
921752	AA2-053 C	3.26
921753	AA2-053 E	1.4
921762	AA2-057 C	2.35
921763	AA2-057 E	1.17
921772	AA2-059 C	0.72
921773	AA2-059 E	0.33
921862	AA2-068 C	0.76
921863	AA2-068 E	0.35
920022	AA2-086 E	0.09
921982	AA2-088 C	2.33
921983	AA2-088 E	3.81
922032	AA2-105 C	0.85
922033	AA2-105 E	0.4
922072	AA2-113 C	0.85
922073	AA2-113 E	0.4
922442	AA2-165 C	0.32
922443	AA2-165 E	0.15
922472	AA2-169 C	0.71
922473	AA2-169 E	0.33
922512	AA2-174 C	0.15
922513	AA2-174 E	0.16
922522	AA2-177 C	6.39
922523	AA2-177 E	2.74
922532	AA2-178 C	2.96
922533	AA2-178 E	1.27

922602	<i>ABI-013 C</i>	0.89
922603	<i>ABI-013 E</i>	5.98
922722	<i>ABI-053 C</i>	0.44
922723	<i>ABI-053 E</i>	0.25
922732	<i>ABI-054 C</i>	2.47
922733	<i>ABI-054 E</i>	1.22
922882	<i>ABI-077 C</i>	1.01
922883	<i>ABI-077 E</i>	6.75
923262	<i>ABI-132 C OP</i>	5.97
923263	<i>ABI-132 E OP</i>	2.56
923572	<i>ABI-173 C OP</i>	0.99
923573	<i>ABI-173 E OP</i>	0.46
923582	<i>ABI-173AC OP</i>	0.99
923583	<i>ABI-173AE OP</i>	0.46
923801	<i>AB2-015 C OP</i>	3.8
923802	<i>AB2-015 E OP</i>	2.76
923831	<i>AB2-022 C</i>	0.66
923832	<i>AB2-022 E</i>	0.35
923851	<i>AB2-025 C</i>	1.62
923852	<i>AB2-025 E</i>	0.73
923911	<i>AB2-031 C OP</i>	1.11
923912	<i>AB2-031 E OP</i>	0.55
923981	<i>AB2-039 C OP</i>	5.76
923982	<i>AB2-039 E OP</i>	4.71
923991	<i>AB2-040 C OP</i>	3.79
923992	<i>AB2-040 E OP</i>	2.86
924011	<i>AB2-042 C OP</i>	5.26
924012	<i>AB2-042 E OP</i>	4.19
924071	<i>AB2-051 C OP</i>	39.
924072	<i>AB2-051 E OP</i>	6.06
924161	<i>AB2-060 C OP</i>	2.79
924162	<i>AB2-060 E OP</i>	1.31
924381	<i>AB2-087 C</i>	0.19
924382	<i>AB2-087 E</i>	0.09
924501	<i>AB2-099 C</i>	0.2
924502	<i>AB2-099 E</i>	0.09
924511	<i>AB2-100 C</i>	5.58
924512	<i>AB2-100 E</i>	2.75
924761	<i>AB2-128 C</i>	4.78
924762	<i>AB2-128 E</i>	1.88
924811	<i>AB2-134 C OP</i>	8.19
924812	<i>AB2-134 E OP</i>	10.95
924931	<i>AB2-147 C</i>	1.18
924932	<i>AB2-147 E</i>	1.92
924941	<i>AB2-149 C OP</i>	1.51

924942	AB2-149 E OP	2.47
924951	AB2-150 C OP	1.45
924952	AB2-150 E OP	2.37
924961	AB2-152	15.85
925051	AB2-160 C OP	4.05
925052	AB2-160 E OP	6.61
925061	AB2-161 C OP	2.37
925062	AB2-161 E OP	3.87
925121	AB2-169 C OP	2.01
925122	AB2-169 E OP	1.8
925141	AB2-171 C OP	1.75
925142	AB2-171 E OP	2.85
925171	AB2-174 C OP	3.49
925172	AB2-174 E OP	3.16
925281	AB2-186 C	0.18
925282	AB2-186 E	0.08
925291	AB2-188 C OP	0.73
925292	AB2-188 E OP	0.33
925331	AB2-190 C	14.6
925332	AB2-190 E	3.65

Appendix 5

(DVP - DVP) The 6CHSTF B-6MESSER 230 kV line (from bus 314287 to bus 314228 ckt 1) loads from 133.21% to 133.68% (**DC power flow**) of its emergency rating (399 MVA) for the tower line contingency outage of 'LN 208-259'. This project contributes approximately 4.1 MW to the thermal violation.

CONTINGENCY 'LN 208-259'

OPEN BRANCH FROM BUS 314286 TO BUS 314309 CKT 1 /* 6CHSTF A
230.00 - 6IRON208 230.00

OPEN BRANCH FROM BUS 314309 TO BUS 314338 CKT 1 /* 6IRON208
230.00 - 6SOUWEST 230.00

OPEN BUS 314309 /* ISLAND

OPEN BRANCH FROM BUS 314276 TO BUS 314287 CKT 1 /* 6BASIN 230.00 -
6CHSTF B 230.00

END

<i>Bus Number</i>	<i>Bus Name</i>	<i>Full Contribution</i>
315065	1CHESTF6	37.23
315077	1HOPHCF1	2.16
315078	1HOPHCF2	2.16
315079	1HOPHCF3	2.16
315080	1HOPHCF4	3.27
315076	1HOPPOLC	1.84
315073	1STONECA	5.67
314784	1WEYRHSB	0.66
314314	3LOCKS	1.04
314539	3UNCAMP	0.86
314541	3WATKINS	0.25
314229	6MT R221	-0.33
292791	U1-032 E	2.95
900672	V4-068 E	0.11
901082	W1-029E	13.49
902241	W2-022 C OPI	0.49
902242	W2-022 E OPI	3.31
903520	W3-066 C1OPI	0.98
903531	W3-066 C2OPI	0.98
903522	W3-066 E1OPI	6.54
903532	W3-066 E2OPI	6.54
907092	X1-038 E	2.15
913392	Y1-086 E	0.63
914231	Y2-077	0.87

916042	Z1-036 E	13.59
916192	Z1-068 E	0.53
917122	Z2-027 E	0.31
917332	Z2-043 E	0.34
917342	Z2-044 E	0.18
917592	Z2-099 E	0.16
921092	AA1-049 C	0.68
921093	AA1-049 E	0.32
921162	AA1-063AC	3.19
921163	AA1-063AE	1.51
918512	AA1-065 E OP	1.48
918562	AA1-072 E	0.06
921532	AA1-132 C	2.1
921533	AA1-132 E	0.9
921552	AA1-134 C	2.89
921553	AA1-134 E	1.24
921562	AA1-135 C	2.95
921563	AA1-135 E	1.26
921572	AA1-138 C	3.
921573	AA1-138 E	1.29
921752	AA2-053 C	3.26
921753	AA2-053 E	1.4
921762	AA2-057 C	2.35
921763	AA2-057 E	1.17
921772	AA2-059 C	0.72
921773	AA2-059 E	0.33
921862	AA2-068 C	0.76
921863	AA2-068 E	0.35
920022	AA2-086 E	0.09
921982	AA2-088 C	2.33
921983	AA2-088 E	3.81
922032	AA2-105 C	0.85
922033	AA2-105 E	0.4
922072	AA2-113 C	0.85
922073	AA2-113 E	0.4
922442	AA2-165 C	0.32
922443	AA2-165 E	0.15
922472	AA2-169 C	0.71
922473	AA2-169 E	0.33
922512	AA2-174 C	0.15
922513	AA2-174 E	0.16
922522	AA2-177 C	6.39
922523	AA2-177 E	2.74
922532	AA2-178 C	2.96
922533	AA2-178 E	1.27

922602	<i>ABI-013 C</i>	0.89
922603	<i>ABI-013 E</i>	5.98
922722	<i>ABI-053 C</i>	0.44
922723	<i>ABI-053 E</i>	0.25
922732	<i>ABI-054 C</i>	2.47
922733	<i>ABI-054 E</i>	1.22
922882	<i>ABI-077 C</i>	1.01
922883	<i>ABI-077 E</i>	6.75
923262	<i>ABI-132 C OP</i>	5.97
923263	<i>ABI-132 E OP</i>	2.56
923572	<i>ABI-173 C OP</i>	0.99
923573	<i>ABI-173 E OP</i>	0.46
923582	<i>ABI-173AC OP</i>	0.99
923583	<i>ABI-173AE OP</i>	0.46
923801	<i>AB2-015 C OP</i>	3.8
923802	<i>AB2-015 E OP</i>	2.76
923831	<i>AB2-022 C</i>	0.66
923832	<i>AB2-022 E</i>	0.35
923851	<i>AB2-025 C</i>	1.62
923852	<i>AB2-025 E</i>	0.73
923911	<i>AB2-031 C OP</i>	1.11
923912	<i>AB2-031 E OP</i>	0.55
923981	<i>AB2-039 C OP</i>	5.76
923982	<i>AB2-039 E OP</i>	4.71
923991	<i>AB2-040 C OP</i>	3.79
923992	<i>AB2-040 E OP</i>	2.86
924011	<i>AB2-042 C OP</i>	5.26
924012	<i>AB2-042 E OP</i>	4.19
924071	<i>AB2-051 C OP</i>	39.
924072	<i>AB2-051 E OP</i>	6.06
924161	<i>AB2-060 C OP</i>	2.79
924162	<i>AB2-060 E OP</i>	1.31
924381	<i>AB2-087 C</i>	0.19
924382	<i>AB2-087 E</i>	0.09
924501	<i>AB2-099 C</i>	0.2
924502	<i>AB2-099 E</i>	0.09
924511	<i>AB2-100 C</i>	5.58
924512	<i>AB2-100 E</i>	2.75
924761	<i>AB2-128 C</i>	4.78
924762	<i>AB2-128 E</i>	1.88
924811	<i>AB2-134 C OP</i>	8.19
924812	<i>AB2-134 E OP</i>	10.95
924931	<i>AB2-147 C</i>	1.18
924932	<i>AB2-147 E</i>	1.92
924941	<i>AB2-149 C OP</i>	1.51

924942	AB2-149 E OP	2.47
924951	AB2-150 C OP	1.45
924952	AB2-150 E OP	2.37
924961	AB2-152	15.85
925051	AB2-160 C OP	4.05
925052	AB2-160 E OP	6.61
925061	AB2-161 C OP	2.37
925062	AB2-161 E OP	3.87
925121	AB2-169 C OP	2.01
925122	AB2-169 E OP	1.8
925141	AB2-171 C OP	1.75
925142	AB2-171 E OP	2.85
925171	AB2-174 C OP	3.49
925172	AB2-174 E OP	3.16
925281	AB2-186 C	0.18
925282	AB2-186 E	0.08
925291	AB2-188 C OP	0.73
925292	AB2-188 E OP	0.33
925331	AB2-190 C	14.6
925332	AB2-190 E	3.65