

***Generation Interconnection
Combined Feasibility/System
Impact Study Report***

For

***PJM Generation Interconnection Request
Queue Position AD1-109***

Canton 34.5 kV

April 2018

Preface

The intent of the feasibility study is to determine a plan, with ballpark cost and construction time estimates, to connect the subject generation to the PJM network at a location specified by the Interconnection Customer. The Interconnection Customer may request the interconnection of generation as a capacity resource or as an energy-only resource. As a requirement for interconnection, the Interconnection Customer may be responsible for the cost of constructing: (1) Direct Connections, which are new facilities and/or facilities upgrades needed to connect the generator to the PJM network, and (2) Network Upgrades, which are facility additions, or upgrades to existing facilities, that are needed to maintain the reliability of the PJM system.

In some instances a generator interconnection may not be responsible for 100% of the identified network upgrade cost because other transmission network uses, e.g. another generation interconnection, may also contribute to the need for the same network reinforcement. The possibility of sharing the reinforcement costs with other projects may be identified in the feasibility study, but the actual allocation will be deferred until the impact study is performed.

The Feasibility Study estimates do not include the feasibility, cost, or time required to obtain property rights and permits for construction of the required facilities. The project developer is responsible for the right of way, real estate, and construction permit issues. For properties currently owned by Transmission Owners, the costs may be included in the study.

General

Alpaca Energy LLC, the Interconnection Customer (IC), has proposed an uprate to an existing Natural Gas generating facility located at Bradford County, PA. This projects requests an increase to the install capability of 1.1 MW with 1.1 MW of this output being recognized by PJM as capacity. The installed facilities will have a total capability of 21 MW with 21 MW of this output being recognized by PJM as capacity. The proposed in-service date for this project is September 1, 2017. **This study does not imply a Penelec commitment to this in-service date.**

Point of Interconnection

AD1-109 will interconnect with the Penelec distribution system by tapping the West Leroy 34.5kV circuit.

Cost Summary

The AD1-109 project will be responsible for the following costs:

Description	Total Cost
Attachment Facilities	\$ 0
Direct Connection Network Upgrades	\$ 0
Non Direct Connection Network Upgrades	\$ 0
Total Costs	\$ 0

In addition, the AD1-109 project may be responsible for a contribution to the following costs:

Description	Total Cost
New System Upgrades	\$ 0
Previously Identified Upgrades	\$ 0
Total Costs	\$ 0

Attachment Facilities

No Attachment Facilities are required to support this interconnection request.

Direct Connection Cost Estimate

No Direct Connection Facilities are required to support this interconnection request.

Non-Direct Connection Cost Estimate

No Non-Direct Connection Facilities are required to support this interconnection request.

PJM Requirements

The Interconnection Customer will be required to install equipment necessary to provide Revenue Metering (KWH, KVARH) and real time data (KW, KVAR) for IC's generating Resource. See PJM Manuals M-01 and M-14D, and PJM Tariff Sections 24.1 and 24.2.

FE Requirements

The Interconnection Customer will be required to comply with all FE Revenue Metering Requirements for Generation Interconnection Customers. The Revenue Metering Requirements may be found within the "FirstEnergy Requirements for Transmission Connected Facilities" document located at the following links:

<http://www.firstenergycorp.com/feconnect>

<http://www.pjm.com/planning/design-engineering/to-tech-standards.aspx>

Introduction

This Feasibility/System Impact Study report provides the documentation of an assessment that has been performed by PJM Interconnection and FirstEnergy (FE) in response to a request made by the customer Alpaca Energy, LLC for an upgrade of 1.1 MW energy (1.1 MW Capacity) Canton (AD1-109) injection into the Pennsylvania Electric Company (Penelec) Distribution System from the existing natural gas Alpaca plant (see Site Location - Attachments) MFO of 19.9 MW. The upgrade will bring the MFO to 21.0 MW).

Connection Facilities

In compliance with the PJM Generation Interconnection Procedures, Alpaca Energy, LLC has submitted a "Generation Interconnection Feasibility Study agreement" to PJM that identifies it has uprated the existing 3 generators with a MFO of 21.0 MW and an additional energy

capability of 1.1 MW (1.1 MW capacity) at 220 Romaine Lane Canton, Pa. 17724 (see Attachments).

The project was studied as an interconnection into the Pennsylvania Electric Company distribution system via the existing facilities at a tap on the West Leroy circuit at pole # 225738B54651 (see Attachments). The Canton (AD1-109) Project has no direct connection facilities that require upgrades.

Power Flow Analysis (New Project Upgrades and Contributions)

A Power Flow study was conducted to determine the reliability impact of the proposed Canton (AD1-109) Project on the FE Bulk Transmission System (greater than 100 kV). This included the performance of a contingency analysis to identify any facility overload or voltage condition that violates the FE Planning Criteria. Any such violation that is either directly attributable to this project or for which it will have a shared responsibility is included in this report with a least cost plan identified to mitigate them. The Canton (AD1-109) Project Power Flow Analysis was completed using a 2021 summer peak load base case power flow provided by the PJM staff. This base case included an equivalent representation of the Penelec 34.5kV distribution system modeled as lumped equivalent load at the Grover 230 kV substation. The Canton (AD1-109) Project was modeled at the Grover 34.5 kV substation existing facilities. A simulation of all possible contingencies within the NERC and FE Planning Standards that are impacted by the Canton (AD1-109) Project was conducted to test for criteria compliance. The conclusion from this analysis is that there are no new bulk electric system network upgrades required for the Canton (AD1-109) Project. Furthermore, there are no findings of previously identified criteria violations from other generation or transmission interconnection projects in which the Canton (AD1-109) Project contributes.

Power Flow Analysis (Detailed 34.5kV)

In order to identify any overloads or voltage conditions on the 34.5kV system near the Canton (AD1-109) Project, Pennsylvania Electric Company studied its own detailed model for the 2021 Penelec Summer Peak case. The Canton (AD1-109) Project was modeled with the additional 1.1 MW energy/capacity output (see Attachments).

1.1 MW Energy/Capacity Output

No overload/voltage issues identified

Short Circuit and Dynamics Analysis

No problems were identified. A circuit breaker analysis was completed for the AD1-109 study. No overdutied breakers were found to be directly attributable to the AD1-109 project.

System Protection Analysis

A review was conducted to assess the impact of the Canton (AD1-109) Project on the system protection requirements in the area. The results of this review show that no relay additions or modifications will be required.

Metering

Penelec owns the existing meter in Z2-011 and will continue to own it. No metering upgrades are required for this project upgrade.

Compliance Issues

Alpaca Energy, LLC must also meet all PJM, ReliabilityFirst and NERC reliability criteria and operating procedures required for standards compliance. For example, the Developer will need to properly locate and report the over and under-voltage and over and under-frequency system protection elements for its units as well as the submission of the generator model and protection data required to satisfy the PJM and ReliabilityFirst audits. Failure to comply with these requirements may result in a

disconnection of service if the violation is found to compromise the reliability of the FE system.

FE Facility Upgrades and Costs

The results from the power flow analysis show that there are no FE criteria violations that are directly attributable to the capacity of the Canton (AD1-109) Project. Furthermore, there are no violations affecting thermal overload on network branches in which the capacity of the Canton (AD1-109) Project is a contributor.

Generation Connection Requirements

The proposed interconnection facilities must be designed in accordance with Attachment 3, FirstEnergy's "Generator Interconnection Technical Requirements for Distribution Connected Facilities" and must also meet IEEE 1547.

<http://www.pjm.com/planning/design-engineering/to-tech-standards/private-firstenergy.aspx>

Alpaca Energy, LLC Requirements

In addition to the FE facilities, Alpaca Energy, LLC will also be responsible for meeting all criteria as specified in the applicable sections of the "FE Requirements for Transmission Connected Facilities" document including:

1. A compliance with the FE and PJM generator power factor and voltage control requirements. The project must maintain a power factor of 1.0 (unity) to .90 lagging measured at the Point of Interconnection.

<http://www.pjm.com/planning/design-engineering/to-tech-standards/private-firstenergy.aspx>

Summary

The Canton (AD1-109) Project uprate will require no facility upgrades. The Canton (AD1-109) Project does not have network upgrades.

Network Impacts

The Queue Project AD1-109 was evaluated as a 1.1 MW (Capacity 1.1 MW) uprate to Queue Project Z2-011 in the PenElec area. Project AD1-109 was evaluated for compliance with applicable reliability planning criteria (PJM, NERC, NERC Regional Reliability Councils, and Transmission Owners). Project AD1-109 was studied with a commercial probability of 53%. Potential network impacts were as follows:

Summer Peak Analysis - 2021

Generator Deliverability

(Single or N-1 contingencies for the Capacity portion only of the interconnection)

None.

Multiple Facility Contingency

(Double Circuit Tower Line, Fault with a Stuck Breaker, and Bus Fault contingencies for the full energy output)

None.

Contribution to Previously Identified Overloads

(This project contributes to the following contingency overloads, i.e. "Network Impacts", identified for earlier generation or transmission interconnection projects in the PJM Queue)

None.

Short Circuit

(Summary of impacted circuit breakers)

None.

Potential Congestion due to Local Energy Deliverability

PJM also studied the delivery of the energy portion of this interconnection request. Any problems identified below are likely to result in operational restrictions to the project under study. The developer can proceed with network upgrades to eliminate the operational restriction at their discretion by submitting a Merchant Transmission Interconnection request.

Note: Only the most severely overloaded conditions are listed below. There is no guarantee of full delivery of energy for this project by fixing only the conditions listed in this section. With a Transmission Interconnection Request, a subsequent analysis will be performed which shall study all overload conditions associated with the overloaded element(s) identified.

None.

New System Reinforcements

(Upgrades required to mitigate reliability criteria violations, i.e. Network Impacts, initially caused by the addition of this project generation)

None.

Contribution to Previously Identified System Reinforcements

(Overloads initially caused by prior Queue positions with additional contribution to overloading by this project. This project may have a % allocation cost responsibility which will be calculated and reported for the Impact Study)

None.

Attachment 1. Project Location



Attachment 2. Single Line Diagram

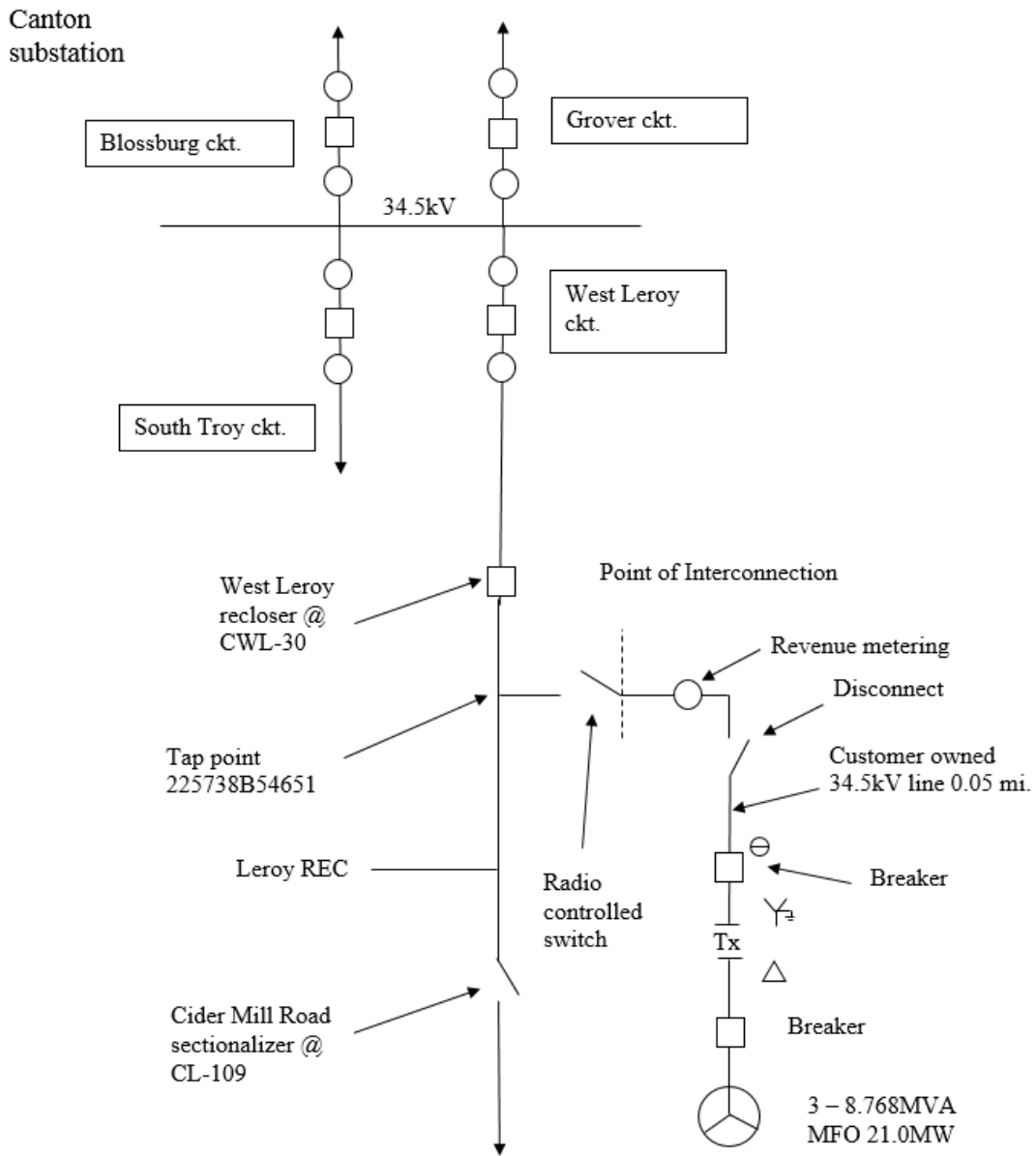

Attachment 3. First Energy Technical Requirements

Applicability

1. This document defines the technical requirements for the interconnection of parallel-operated generation and related equipment to the FirstEnergy distribution system. For purposes of this document the term “generation” includes rotating and inverter-derived generating sources.
2. These requirements apply to customer-owned generation used to offset energy usage and to distributed generation exporting energy on a wholesale basis.
3. This document also applies to standby generator schemes with a make-before-break transition provided that the duration of parallel operation is 100 milliseconds or more.
4. These requirements apply to new generator interconnections as well as existing facilities being upgraded or expanded.

Purpose

The purpose of this document is to ensure the safety of FirstEnergy employees and the public, to protect FirstEnergy equipment from damage and to ensure the reliability of service to FirstEnergy customers.

Applicable Standards

1. Generator facilities must comply with all requirements of the latest version of the IEEE 1547, “Standard for Interconnecting Distributed Resources with Electric Power Systems¹.”
1. Inverter systems must comply with all requirements of the latest version of the UL1741, “Standard for Inverters, Converters, Controllers and Interconnection System Equipment for Use with Distributed Energy Resources².”
2. Generator facilities and equipment must comply with all applicable national, state, and local construction codes and all operation and maintenance-related safety codes, such as the National Electrical Code (NEC), the National Electrical Safety Code (NESC), and the Occupational Safety and Health Administration (OSHA) regulations.
3. Generator interconnections are subject to applicable Federal or State interconnection rules and regulations depending upon interconnection type.

Relaying and Protection

4. The generator owner is responsible for providing adequate protection to FirstEnergy

¹ IEEE Standard 1547-2003, “IEEE Standard for Interconnecting Distributed Resources with Electric Power Systems,” July 28, 2003.

² Underwriters Laboratory U.L. 1741, “Standard for Inverters, Converters, Controllers and Interconnection System Equipment for Use With Distributed Energy Resources,” May 7, 1999.

facilities for conditions arising from the operation of generation under all FirstEnergy distribution system operating conditions. The generator owner is also responsible for providing adequate protection to their facility under any distribution system operating condition whether or not their generator is in operation. Conditions may include but are not limited to:

Loss of a single phase of supply

Distribution system faults

Equipment failures

Abnormal voltage or frequency

Lightning and switching surges

Excessive harmonic voltages

Excessive negative sequence voltages

Separation from supply

Synchronizing generator to the distribution system

Re-synchronizing the generation after electric restoration of the supply.

5. The generator must connect to the FirstEnergy system through an interrupting device, which has adequate fault interruption, and withstand capability, and adequate continuous current and voltage rating in accordance with latest IEEE C37 standards. Three-phase generators shall use an interrupting device that interrupts all three phases simultaneously. The tripping control of the circuit interrupting device shall be powered independently of the utility AC source in order to permit operation upon loss of the FirstEnergy supply.
6. Non-certified inverters rated 300 kW or larger and rotating machines rated 300 kW or larger will require the use of utility grade relays at the point of interconnection. Utility-grade relays are also required where multiple generators are connected to the FirstEnergy system through a single point of interconnection and the aggregate generation is 2000 kW or larger. For purposes of this policy, utility-grade relays are defined as follows:
 - Relays comply with the latest IEEE Standard, C37.90, "Relays and Relay Systems Associated with Electric Power Apparatus."
 - Relays have appropriate test plugs/switches for testing the operation of the relay without unwiring or disassembly.
 - Relays have targets to indicate relay operation.
 - Relays have ability to record and store fault events.
7. The generator protection and controls must be designed to coordinate with the reclosing practices of FirstEnergy line protective devices. The generator must cease to energize the FirstEnergy circuit to which it is connected prior to re-closure of any automatic reclosing devices.

8. The generator shall cease to energize the FirstEnergy distribution system for faults on the circuit to which it is connected. The generator shall not reconnect to the FirstEnergy system following a trip from a system protection device, until the FirstEnergy system has been re-energized for a minimum of five minutes.
9. The generator protection and controls shall be designed to prevent the generator from being connected to a de-energized FirstEnergy circuit.

Voltage Control & Flicker

10. The generator shall be capable of paralleling with the FirstEnergy system without causing a voltage fluctuation at the point of common coupling (PCC) greater than 5% of the prevailing voltage level of the FirstEnergy system at the PCC.
11. The generator must have adequate protection and controls to ensure the requirements for frequency, voltage, and phase angle shown in Table 1 are met prior to paralleling with the FirstEnergy system.

Table 1: Paralleling requirements for generators connecting to the distribution system.			
Rating of Generator (kVA)	Frequency Difference (Hz)	Voltage Difference (%V)	Phase angle Difference (degrees)
0 - 500	0.3	10	20
500 - 1500	0.2	5	15
> 1500	0.1	3	10

1. The generator shall not be a source of excessive harmonic voltage and current distortion and/or voltage flicker. Limits for harmonic distortion (including inductive telephone influence factors) will be as published in the latest issues of IEEE 519, "Recommended Practices and Requirements for Harmonic Control in Electrical Power Systems³." Flicker occurring at the point of common coupling serving other FirstEnergy customers shall remain below the Border Line of Visibility curve shown in fig. 10-3 of the IEEE 519 Standard. (A.k.a. the GE Flicker Curve). Flicker occurring at the secondary of a service transformer serving a sole DG customer shall remain below the Borderline of Irritability curve.
2. When there is reasonable cause for concern due to the nature of the generation and its location, FirstEnergy may require the installation of a monitoring system to permit ongoing assessment of compliance with these criteria. The monitoring system, if required, will be installed at the generator owner’s expense. Situations where high harmonic voltages and/or currents originate from the distribution system are to be addressed in the Interconnection Agreement.
3. If high voltage, low voltage, or objectionable voltage flicker arises due to the

³ IEEE Standard 519-1992, “IEEE Recommended Practices and Requirements for Harmonic Control in Electrical Power Systems,” Second printing June 15, 2004

operation, frequent tripping, and/or frequent starting and stopping of the generator, the generator owner may be required to disconnect its generation equipment from the FirstEnergy system until the problem has been fully investigated and resolved.

4. The operation of the generator equipment must not result in harmonic currents or voltages at the point of common coupling that will interfere with FirstEnergy's metering accuracy and/or proper operation of facilities and/or with the loads of other FirstEnergy customers. Such adverse effects may include, but are not limited to heating of wiring and equipment, overvoltage, communication interference, harmonic resonance, etc.
5. DC injection from inverters shall be maintained at or below 0.5% of full rated inverter output current into the point of common coupling.
6. The generated voltage shall follow, not attempt to oppose or regulate, changes in the prevailing voltage level provided by FirstEnergy at the point of common coupling, unless otherwise mutually agreed to by the generator owner and FirstEnergy.
1. The generator must not interfere with the operation of FirstEnergy voltage regulating equipment including voltage regulators and line capacitors such that the service voltage to other FirstEnergy customers falls outside the limits specified in ANSI C84.1⁴, Range A.
2. Voltage unbalance at the point of common coupling caused by the generator equipment under any condition shall not exceed 3% (ratio of maximum deviation from average voltage to the average voltage).⁵
3. A generator connected to an area network system shall not cause tripping of network protectors due to reversal of power flow.

Response to abnormal voltage

4. The protection functions of the interconnection system shall detect the effective (RMS) or fundamental frequency value of each phase-to-phase voltage, except where the transformer connecting the generator to the FirstEnergy system is a grounded wye-wye configuration, or single-phase installation, the phase-to-neutral voltage shall be detected.
5. When any voltage is in a range given in Table 2 the generator shall cease to energize the FirstEnergy system within the clearing time as indicated. Clearing time is the time between the start of the abnormal condition and the generator ceasing to energize the utility system.

⁴ ANSI C84.1-2006, American National Standard for Electrical Power Systems and Equipment—Voltage Ratings (60 Hertz)

⁵ ANSI C84.1-2006, Annex C, Polyphase Voltage Unbalance, Paragraph C.2

6. For generators 30 kW or larger, different settings may be used for the under/over voltage trip levels or time delays if approved by FirstEnergy. Field-adjustable set points shall be protected against unauthorized adjustment.

Table 2: Interconnection System Response to Abnormal Voltages	
Voltage Range (% of Base Voltage) ^[1]	Clearing time ^[2]
$V < 50 \%$	0.16 Seconds
$50 \% \leq V < 88 \%$	2.00 Seconds
$110\% < V < 120 \%$	1.00 Seconds
$V \geq 120 \%$	0.16 Seconds

[1] Base voltages are the nominal system voltages stated in ANSI C84.1-1995.

[2] For generators ≥ 30 kW times may be extended if approved by FirstEnergy.

7. Voltages shall normally be detected at the PCC to eliminate the effects of voltage drop or transformer connections between the PCC and the point of generator interconnection. However, under any of the following conditions the voltages may be detected at the point of generator interconnection:

The aggregate capacity of the generator system connected to a single PCC is less than or equal to 30 kW,

The interconnection equipment is certified to pass a non-islanding test for the system to which it is to be connected,

The aggregate generator capacity is less than 50% of the total local electric power system minimum annual integrated electrical demand for a 15 minute time period, and export of real or reactive power by the generator to the FirstEnergy system is not permitted.

Response to abnormal frequency

8. When the system frequency is in a range given in Table 3, the generator shall cease to energize the FirstEnergy system within the clearing time as indicated. Clearing time is the time between the start of the abnormal condition and the generator ceasing to energize the FirstEnergy system.
9. For generators greater than 30 kW, the frequency and time delay set points shall be field adjustable. Field-adjustable set points shall be protected against unauthorized adjustment.

Generator Size	Frequency Range (Hz)	Clearing time
≤ 30 kW	> 60.5	0.16 Sec
	< 59.3	0.16 Sec
> 30 kW	> 60.5	0.16 Sec
	< 59.3 ^[1]	0.25 Sec ^[2]
	< 57.0	0.16 Sec

[1] < {59.8 – 57.0 Hz} Allowable setting under approval from FirstEnergy.

[2] {0.16 to 300 Sec} Allowable setting under approval from FirstEnergy.

Islanding Protection

- The generator protection and controls must be able to detect an island condition and disconnect the generator from the FirstEnergy system within two seconds of the formation of an island. The anti-islanding requirement can be satisfied by using any of the following methods, subject to the approval of FirstEnergy.

Direct Transfer Trip Scheme,

Use of frequency relays and voltage relays,

The generator's protection package or the inverter is certified to pass an anti-islanding test (certified to comply with IEEE 1547),

Non-exporting customer generator with reverse power relaying applied at the point of interconnection.

Direct Transfer Trip (DTT) Scheme

- FirstEnergy will make the determination if a DTT scheme is required on a case-by-case basis. A DTT scheme will typically be required when both of the following are true:

The generator is any of the following types; a synchronous machine, a non-certified inverter, or a self-excited induction generator, each capable of sustaining a load when separated from the utility system;

The minimum circuit load on the line section connected to the generator following the opening of any automatic sectionalizing devices is not greater than 3 times the aggregate generation capacity.

- The DTT scheme design, equipment and type of communication channel shall be proposed by the generator owner and submitted to FirstEnergy for review and acceptance.
- The DTT scheme must be designed to automatically trip and separate the generator from the FirstEnergy distribution system upon loss of communication channel. The generator shall not reconnect to the system until the communication channel is proven to functioning normally.

14. Responsibilities for purchase, installation and ownership of DTT equipment will be as follows:

The generator owner shall own and provide a direct-transfer trip receiver(s) at their facility to receive tripping signals originating from a FirstEnergy location(s).

The generator owner shall bear the costs to purchase and install the required DTT transmitting and associated relaying equipment at the required FirstEnergy location(s). FirstEnergy will perform or coordinate the installation of the equipment at the cost of the generator owner. FirstEnergy will own and be responsible to maintain and perform periodic maintenance and testing of this equipment.

The generator owner is responsible for the design, installation and maintenance of a dedicated communication channel(s) between the FirstEnergy location(s) and the generation owner's facility, including any rental, license and attachment fees for the communications channel.

When DTT equipment needs replacement due to age or continued unreliable performance, the generator owner is responsible for purchase and installation costs of the new equipment. This must be established in the Interconnection agreement with the generator owner.

15. If the generator owner wishes to install communications cables or equipment on FirstEnergy poles, the generator owner will be responsible to secure a license agreement or pole attachment agreement for those attachments, and assume typical licensed attachment responsibilities in terms of make-ready work costs and annual attachment fees. Cable attachment will be in the communications space on the poles.
16. When a DTT tripping signal originates from a FirstEnergy substation breaker, the preferred location for DTT transmitter and associated equipment is within the FirstEnergy substation control room or approved outdoor enclosure within the substation perimeter if a control room is not available.
17. FirstEnergy will establish a demarcation point for any DTT communication cables leaving the substation property. FirstEnergy will perform or coordinate the installation of the cable and conduit up to the demarcation point including the box enclosure. FirstEnergy will determine the enclosure location. All material and installation costs will be borne by the generator owner. The generator owner will be responsible to install cable and conduit originating from their end up to the demarcation point. Details of the planned installation including any trenching must be approved by FirstEnergy.
18. The generator owner may be responsible to compensate FirstEnergy for any labor expenses involved with troubleshooting or testing of the DTT communications or protection system. This requirement is to be contractually addressed in the Interconnection Agreement with the generator owner.

Disconnect Switch Requirements

1. FirstEnergy requires that a disconnect device with a visibly open means be provided,

installed, and paid for by the generator owner, which is readily accessible to and lockable by FirstEnergy personnel, in order to safely disconnect the generator from the FirstEnergy system.⁶

2. The disconnect device may be installed either at the primary voltage level or secondary voltage level at the discretion of FirstEnergy. The generator disconnect device must be clearly labeled to show its intended function.

Interconnection Transformer Requirements

3. All generation must be isolated from the FirstEnergy primary distribution system by a transformer in order to properly integrate the grounding scheme of the generator to the grounding scheme of the distribution system.
4. The grounding scheme of the interconnection transformer shall not cause overvoltages on the un-faulted phases during ground-fault conditions that exceed the rating of equipment connected to the FirstEnergy distribution system.
5. The ground source contribution current of the interconnection transformer shall not disrupt the coordination of the overcurrent devices of the distribution circuit whether or not the generator is in operation.

Maintenance Requirements

6. The generator owner shall maintain all equipment associated with the generator system, including DTT communications equipment, according to good utility practices and according to equipment manufacturer's recommendations and keep it in proper working condition.
7. The generator owner shall keep a written log and test records showing the periodic testing of such equipment. These records must be available to FirstEnergy upon request.

Acceptance Testing

8. Test results or equipment pre-certification shall be supplied by the generator owner, that verify, to the satisfaction of FirstEnergy, compliance with the IEEE 1547 Standard, Section 5 "Interconnection Test Specifications and Requirements."
9. The generator owner must provide FirstEnergy the opportunity to perform an inspection prior to interconnection to verify correct protective settings and wiring connections.
10. Acceptance testing shall be performed on all generators and generating equipment not pre-certified by a nationally recognized testing laboratory as suitable for utility interconnection meeting the intent of these technical requirements. A qualified third

⁶ Exception: In New Jersey, an outdoor disconnect switch is not a requirement for Level 1 interconnections per NJ Net metering regulations. See NJ Administrative Code, NJAC 14:8-4.1 et seq.(2008)

party testing organization shall perform these tests at the expense of the generator owner.

11. Acceptance testing of the protective schemes, where required, must be completed on new or modified installations.

Communications and Control

12. FirstEnergy may require the generator owner to provide a listing of two or more persons and their telephone numbers such that the FirstEnergy dispatching office can contact the generator owner for emergency switching operations 24 hours a day. This is a necessary safety requirement.
13. For generators rated 2000 kVA or larger, individually or in aggregate, who are exporting energy on a wholesale basis, will require the generator owner to furnish a SCADA remote terminal unit (RTU) which will interface with the FirstEnergy energy management system (EMS). The RTU, the communications channel and all related equipment will be furnished and maintained by the generator owner. The RTU must communicate with the FirstEnergy EMS via DNP 3.0 protocol. The following control, status, and metering points will be required:

Tripping control of generator or interconnection breaker.

Generator real and reactive power output measured at the high-side of the generator step-up transformer.

Generator voltage at the point of interconnection.

Indication that a direct-transfer trip operation has occurred where DTT is used.

14. Where tripping control of generator breaker is required, the tripping command originating from the FirstEnergy dispatching office must also activate a closing lockout function which must be manually reset before the generator breaker can be re-connected to the system.

Metering Requirements

15. Metering instrument transformers are to be protected from the distribution system by a fuse or other protective device such that failure of an instrument transformer does not cause a distribution protection device to open.
16. In the case of an existing retail customer that is adding generation their facility, the retail billing meter will need to be replaced with a bi-directional meter. A review of the wiring and current transformers may need to be performed to verify the ampacity ratings are sufficient for the size of the generator. Cost responsibilities for meter replacement are defined in the retail net metering tariffs.
17. Wholesale generation facilities must comply with the metering requirements of the appropriate RTO.
18. Wholesale generation facilities must comply with the FirstEnergy requirements specified in the document entitled "FirstEnergy Revenue Metering Requirements For

Generation Facilities Connected 46 kV and Lower.”

1. Generators with an aggregate capacity of 1000 kVA or larger may require the installation of an interval metering system, which will transfer metering data to the FirstEnergy MV-90 system⁷. The meter will be provided by FirstEnergy. The generator owner will be responsible to provide at their cost a dedicated communications channel, which will interface with FirstEnergy’s MV-90 system.
2. Cost responsibilities associated with the purchase, installation, and testing and of revenue metering equipment will be determined on a case-by-case basis under the direction of the FirstEnergy Corporate Metering Department and in accordance with the rules found in filed tariffs. These details are to be addressed in the facilities study.
3. Metering equipment must meet the specifications of FirstEnergy and the appropriate RTO.

Definitions

Area Network System - A type of electric distribution system served by multiple transformers interconnected in an electrical network circuit, which is generally used in large metropolitan areas that are densely populated, in order to provide highly reliable service. Area network has the same meaning as the term “distribution secondary grid network” found in institute of electrical and electronics engineers (IEEE) standard 1547.

Certified Equipment – Equipment which has been submitted by a manufacturer to an OSHA-approved nationally recognized testing laboratory, and has been tested and listed by the laboratory for continuous interactive operation with an electric distribution system in compliance with the applicable codes and standards listed in the IEEE 1547 and UL 1741 Standards.

Flicker – A variation of input voltage sufficient in duration to allow visual observation of a change in electric light source intensity.

Harmonic Distortion – Continuous distortion of the normal sine wave; typically caused by nonlinear loads or by inverters.

Inverter – A device or system that changes direct current power to alternating current power. Inverters that are self-commutating can be configured for stand-alone service. Inverters that are line-commutated cannot be configured for stand-alone service.

Point of Common Coupling – The point at which the generator facility is connected to the shared portion, or potentially shared portion of the FirstEnergy system. The IEEE 1547 standard establishes this point as the location where voltage and harmonic limits are measured and applied.

Regional Transmission Organization (RTO) – An independent, FERC-approved organization of sufficient regional scope, which coordinates the interstate movement of electricity under FERC-approved Tariffs by operating the transmission system and competitive wholesale electricity markets, and ensuring reliability and efficiency through expansion planning and interregional coordination.

Single Phasing Condition – Occurs when one or two phases of the three phase supply line are disconnected.

⁷ MV-90 is FirstEnergy’s system for collecting interval metering data.

Unintentional Island - An unplanned condition where one or more generator's and a portion of the FirstEnergy system remain energized solely through the point of interconnection.