

***Generation Interconnection
Feasibility Study Report***

For

***PJM Generation Interconnection Request
Queue Position AD2-200***

***Briery – Clover 230kV
9.5 MW Capacity / 14 MW Energy***

September / 2018

Introduction

This Feasibility Study has been prepared in accordance with the PJM Open Access Transmission Tariff, 36.2, as well as the Feasibility Study Agreement between the Interconnection Customer (IC), and PJM Interconnection, LLC (PJM), Transmission Provider (TP). The Interconnected Transmission Owner (ITO) is Virginia Electric and Power Company (VEPCO).

Preface

The intent of the Feasibility Study is to determine a plan, with high level estimated cost and construction time estimates, to connect the subject generation to the PJM network at a location specified by the IC. The IC may request the interconnection of generation as a capacity resource or as an energy-only resource. As a requirement for interconnection, the IC may be responsible for the cost of constructing: (1) Direct Connections, which are new facilities and/or facilities upgrades needed to connect the generator to the PJM network, and (2) Network Upgrades, which are facility additions, or upgrades to existing facilities, that are needed to maintain the reliability of the PJM system.

In some instances a generator interconnection may not be responsible for 100% of the identified network upgrade cost because other transmission network uses, e.g. another generation interconnection, may also contribute to the need for the same network reinforcement. The possibility of sharing the reinforcement costs with other projects may be identified in the Feasibility Study, but the actual allocation will be deferred until the Impact Study is performed.

The Feasibility Study estimates do not include the feasibility, cost, or time required to obtain property rights and permits for construction of the required facilities. The IC is responsible for the right of way, real estate, and construction permit issues. For properties currently owned by ITO, the costs may be included in the study.

General

The IC has proposed a solar generating facility located in Mecklenburg County, VA. The installed facilities will have a total capability of 124.5 MW with 84.7 MW of this output being recognized by PJM as capacity. This queue request is for an additional 14 MW with 9.5 MW of this output being recognized by PJM as capacity. The proposed in-service date for this project is 9/02/2019. **This study does not imply an ITO commitment to this in-service date.**

Point of Interconnection

AD2-200 will interconnect with the ITO transmission system via a new three breaker ring bus switching station that connects on the Briery - Clover 230kV line #235.

Cost Summary

The AD2-200 project will be responsible for the following costs:

Description	Total Cost
Attachment Facilities	\$0
Direct Connection Network Upgrades	\$0
Non Direct Connection Network Upgrades	\$0

Description	Total Cost
Total Costs	\$0

In addition, the AD2-200 project may be responsible for a contribution to the following costs:

Description	Total Cost
New System Upgrades	\$18,500,000
Previously Identified Upgrades	\$0
Total Costs	\$18,500,000

Cost allocations for these upgrades will be provided in the System Impact Study Report.

Note: PJM Open Access Transmission Tariff (OATT) section 217.3A outline cost allocation rules. The rules are further clarified in PJM Manual 14A Attachment B. For New System Upgrades, the allocation of costs for a network upgrade will start with the first Queue project to cause the need for the upgrade. Later queue projects will receive cost allocation contingent on their contribution to the violation and are allocated to the queues that have not closed less than 5 years following the execution of the first Interconnection Service Agreement which identifies the need for this upgrade.

The Feasibility Study is used to make a preliminary determination of the type and scope of Attachment Facilities, Local Upgrades, and Network Upgrades that will be necessary to accommodate the Interconnection Request and to provide the Interconnection Customer a preliminary estimate of the time that will be required to construct any necessary facilities and upgrades and the Interconnection Customer’s cost responsibility. The System Impact Study provides refined and comprehensive estimates of cost responsibility and construction lead times for new facilities and system upgrades. Facilities Studies will include, commensurate with the degree of engineering specificity as provided in the Facilities Study Agreement, good faith estimates of the cost, determined in accordance with Section 217 of the Tariff,

- (a) to be charged to each affected New Service Customer for the Facilities and System Upgrades that are necessary to accommodate this queue project;
- (b) the time required to complete detailed design and construction of the facilities and upgrades; and
- (c) a description of any site-specific environmental issues or requirements that could reasonably be anticipated to affect the cost or time required to complete construction of such facilities and upgrades.

Attachment Facilities

The existing AD1-088 scope of work is sufficient to accommodate this queue request from an Attachment Facilities and substation expansion perspective. The single line is shown below in Attachment 1.

Non-Direct Connection Cost Estimate

Remote Terminal Work: During the Facilities Study, ITO's System Protection Engineering Department will review transmission line protection as well as anti-islanding required to accommodate the new generation and interconnection substation. System Protection Engineering will determine the minimal acceptable protection requirements to reliably interconnect the proposed generating facility with the transmission system. The review is based on maintaining system reliability by reviewing ITO's protection requirements with the known transmission system configuration which includes generating facilities in the area. This review may determine that transmission line protection and communication upgrades are required at remote substations.

System Reinforcement

Wreck and rebuild Mount Eagle - Charlottesville 230 kV Line #2028 of 7.5 miles to increase its line rating to 722 MVA (normal), 722 MVA (emergency), and 830 MVA (load dump). It is estimated cost \$18,500,000 and to take 44-48 months to engineer, permit and construct. A VA CPCN is required.

Interconnection Customer Requirements

ITO's Facility Connection Requirements as posted on PJM's website

<http://www.pjm.com/~media/planning/plan-standards/private-dominion/facility-connection-requirements1.ashx>

An Interconnection Customer entering the New Services Queue on or after October 1, 2012 with a proposed new Customer Facility that has a Maximum Facility Output equal to or greater than 100 MW shall install and maintain, at its expense, phasor measurement units (PMUs). See Section 8.5.3 of Appendix 2 to the Interconnection Service Agreement as well as section 4.3 of PJM Manual 14D for additional information.

Voltage Ride Through Requirements - The Customer Facility shall be designed to remain in service (not trip) for voltages and times as specified for the Eastern Interconnection in Attachment 1 of NERC Reliability Standard PRC-024-1, and successor Reliability Standards, for both high and low voltage conditions, irrespective of generator size, subject to the permissive trip exceptions established in PRC-024-1 (and successor Reliability Standards).

Frequency Ride Through Requirements - The Customer Facility shall be designed to remain in service (not trip) for frequencies and times as specified in Attachment 2 of NERC Reliability Standard PRC-024-1, and successor Reliability Standards, for both high and low frequency condition, irrespective of generator size, subject to the permissive trip exceptions established in PRC-024-1 (and successor Reliability Standards).

Reactive Power - The Generation Interconnection Customer shall design its non-synchronous Customer Facility with the ability to maintain a power factor of at least 0.95 leading to 0.95 lagging measured at the generator's terminals.

Revenue Metering and SCADA Requirements

PJM Requirements

The IC will be required to install equipment necessary to provide Revenue Metering (KWH, KVARH) and real time data (KW, KVAR) for IC's generating Resource. See PJM Manuals M-01 and M-14D, and PJM Tariff Sections 24.1 and 24.2.

Meteorological Data Reporting Requirement

The solar generation facility shall provide the Transmission Provider with site-specific meteorological data including:

- Temperature (degrees Fahrenheit)
- Atmospheric pressure (hectopascals)
- Irradiance
- Forced outage data

Network Impacts

The Queue Project AD2-200 was evaluated as a 14.0 MW (Capacity 9.5 MW) injection tapping the Briery to Clover 230kV line in the ITO area. Project AD2-200 was evaluated for compliance with applicable reliability planning criteria (PJM, NERC, NERC Regional Reliability Councils, and Transmission Owners). Project AD2-200 was studied with a commercial probability of 53%. Potential network impacts were as follows:

PJM assessed the impact of the proposed Queue Project as an injection into the ITO, for compliance with NERC Reliability Criteria. The system was assessed using the summer 2021 RTEP case. When performing analysis, ITO Criteria considers a transmission facility overloaded if it exceeds 94% of its emergency rating under single contingency (normal and stressed system conditions). A full listing of the ITO's Planning Criteria and interconnection requirements can be found in the ITO's Facility Connection Requirements which are publicly available at: <http://www.dom.com>.

The results of these studies evaluate the system under a limited set of operating conditions and do not guarantee the full delivery of the capacity and associated energy of this proposed generation facility under all operating conditions. NERC Planning and Operating Reliability Criteria allow for the re-dispatch of generating units to resolve projected and actual deficiencies in real time and planning studies. Specifically NERC Category C Contingency Conditions (Bus Fault, Tower Line, N-1-1, and Stuck Breaker scenarios) allow for re-dispatch of generating units to resolve potential reliability deficiencies. For ITO Planning Criteria the re-dispatch of generating units for these contingency conditions is allowed as long as the projected loading does not exceed 100% of a facility Load Dump Rating. The results of these studies are discussed in more detail below.

Contingency Descriptions

The following contingencies resulted in overloads:

Contingency Name	Description
DVP_P1-2: LN 2027-A	CONTINGENCY 'DVP_P1-2: LN 2027-A' OPEN BRANCH FROM BUS 314310 TO BUS 314322 CKT 1 /* 6JUDES F 230.00 - 6MDLTHAN 230.00 OPEN BRANCH FROM BUS 314310 TO BUS 314333 CKT 1 /* 6JUDES F 230.00 - 6POWHATN 230.00 OPEN BRANCH FROM BUS 314333 TO BUS 933500 CKT 1 /* 6POWHATN 230.00 - AC2-165 TAP 230.00 OPEN BUS 314310 /* ISLAND OPEN BUS 314333 /* ISLAND END
DVP_P1-2: LN 2027-B	CONTINGENCY 'DVP_P1-2: LN 2027-B' OPEN BRANCH FROM BUS 933500 TO BUS 313868 CKT 1 /* AC2-165 TAP 230.00 - 6CARTERV 230.00 OPEN BRANCH FROM BUS 313868 TO BUS 314747 CKT 1 /* 6CARTERV 230.00 - 6BREMO 230.00 END

Contingency Name	Description
DVP_P1-2: LN 556	CONTINGENCY 'DVP_P1-2: LN 556' OPEN BRANCH FROM BUS 314686 TO BUS 314906 CKT 1 /* 6CLOVER 230.00 - 8CLOVER 500.00 OPEN BRANCH FROM BUS 314686 TO BUS 314906 CKT 2 /* 6CLOVER 230.00 - 8CLOVER 500.00 OPEN BRANCH FROM BUS 314686 TO BUS 314906 CKT 3 /* 6CLOVER 230.00 - 8CLOVER 500.00 OPEN BRANCH FROM BUS 314906 TO BUS 314936 CKT 1 /* 8CLOVER 500.00 - 8RAWLINGS 500.00 OPEN BUS 314906 /* ISLAND END

Summer Peak Analysis - 2021

Generator Deliverability

(Single or N-1 contingencies for the Capacity portion only of the interconnection)

#	Contingency		Affected Area	Facility Description	Bus			Power Flow	Loading %		Rating		MW Contribution	Ref
	Type	Name			From	To	Cir.		Initial	Final	Type	MVA		
1	N-1	DVP_P1-2: LN 2027-A	DVP - DVP	6MTEAGLE-6CHARLVL 230 kV line	314765	314749	1	DC	99.73	100.01	ER	662	1.84	1

Multiple Facility Contingency

(Double Circuit Tower Line, Fault with a Stuck Breaker, and Bus Fault contingencies for the full energy output)

None

Short Circuit

(Summary of impacted circuit breakers)

New circuit breakers found to be over-duty:

None

Contributions to previously identified circuit breakers found to be over-duty:

None

Contribution to Previously Identified Overloads

(This project contributes to the following contingency overloads, i.e. "Network Impacts", identified for earlier generation or transmission interconnection projects in the PJM Queue)

None

Steady-State Voltage Requirements

(Summary of the VAR requirements based upon the results of the steady-state voltage studies)

To be determined during Impact Study

Stability and Reactive Power Requirement for Low Voltage Ride Through

(Summary of the VAR requirements based upon the results of the dynamic studies)

To be determined during Impact Study

New System Reinforcements

(Upgrades required to mitigate reliability criteria violations, i.e. Network Impacts, initially caused by the addition of this project generation)

Violation #	Overloaded Facility	Upgrade Description	Network Upgrade Number	Upgrade Cost
# 1	6MTEAGLE-6CHARLVL 230 kV line	Wreck and rebuild Mount Eagle - Charlottesville 230 kV Line #2028 of 7.5 miles to increase its line rating to 722 MVA (normal), 722 MVA (emergency), and 830 MVA (load dump). It is estimated to take 44-48 months to engineer, permit and construct. A VA CPCN is required.	Pending	\$18,500,000
Total New Network Upgrades				\$18,500,000

Contribution to Previously Identified System Reinforcements

(Overloads initially caused by prior Queue positions with additional contribution to overloading by this project. This project may have a % allocation cost responsibility which will be calculated and reported for the Impact Study)

None

Potential Congestion due to Local Energy Deliverability

PJM also studied the delivery of the energy portion of this interconnection request. Any problems identified below are likely to result in operational restrictions to the project under study. The IC can proceed with network upgrades to eliminate the operational restriction at their discretion by submitting a Merchant Transmission Interconnection request.

Note: Only the most severely overloaded conditions are listed below. There is no guarantee of full delivery of energy for this project by fixing only the conditions listed in this section. With a Transmission Interconnection Request, a subsequent analysis will be performed which shall study all overload conditions associated with the overloaded element(s) identified.

#	Contingency		Affected Area	Facility Description	Bus		Circuit	Power Flow	Loading %		Rating		MW Contribution
	Type	Name			From	To			Initial	Final	Type	MVA	
2	N-1	DVP_P1-2: LN 556	DVP - DVP	6PRINCE EDW-6FARMVIL 230 kV line	313802	314692	1	DC	123.3	124.45	ER	572	6.38
3	N-1	DVP_P1-2: LN 556	DVP - DVP	6BRIERY-6PRINCE EDW 230 kV line	314268	313802	1	DC	124.4	125.48	ER	572	6.38
4	N-1	DVP_P1-2: LN 556	DVP - DVP	6CLOVER-AD1-087 TAP 230 kV line	314686	934610	1	DC	103.7	104.54	ER	749	7.56
5	N-1	DVP_P1-2: LN 2027-B	DVP - DVP	6MTEAGLE-6CHARLVL 230 kV line	314765	314749	1	DC	99.95	100.14	ER	662	2.71
6	N-1	DVP_P1-2: LN 556	DVP - DVP	AC1-162 TAP-6BRIERY 230 kV line	926760	314268	1	DC	125.7	126.83	ER	572	6.38
7	N-1	DVP_P1-2: LN 556	DVP - DVP	AD1-087 TAP-6HALIFAX 230 kV line	934610	314697	1	DC	118.3	119.03	ER	749	7.56
8	N-1	DVP_P1-2: LN 556	DVP - DVP	AD1-088 TAP-AC1-162 TAP 230 kV line	934620	926760	1	DC	101.8	102.94	ER	572	6.38

Light Load Analysis

Light Load Studies to be conducted during later study phases (as required by PJM Manual 14B).

Affected System Analysis & Mitigation

Duke, Progress & TVA Impacts:

Duke Carolina, Progress, & TVA Impacts to be determined during later study phases (as applicable).

Attachment 1.

System Configuration

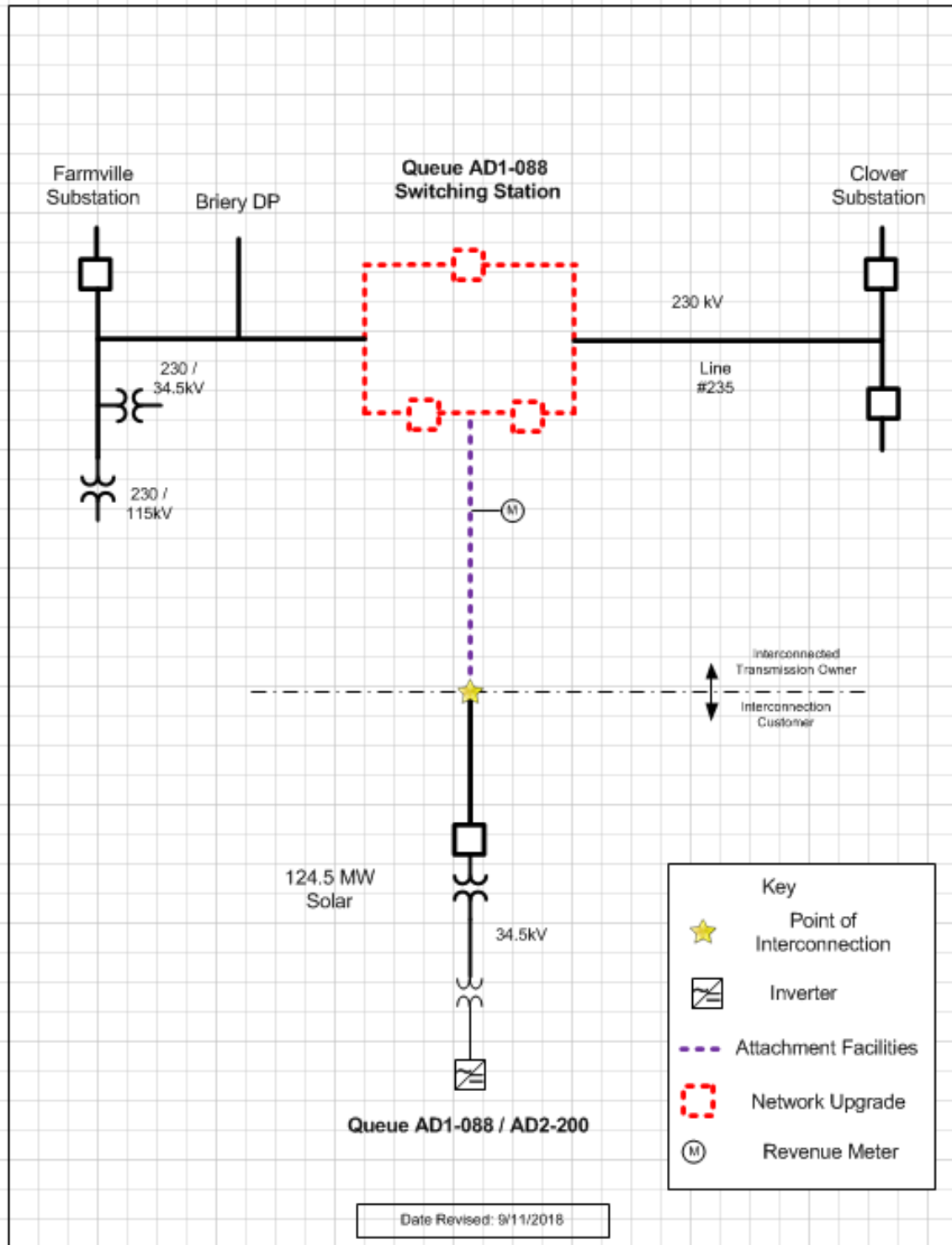

Attachment 2.

Flowgate Appendices – Option 1

Appendices

The following appendices contain additional information about each flowgate presented in the body of the report. For each appendix, a description of the flowgate and its contingency was included for convenience. However, the intent of the appendix section is to provide more information on which projects/generators have contributions to the flowgate in question. Although this information is not used "as is" for cost allocation purposes, it can be used to gauge other generators impact. When a flowgate is identified in multiple analysis the appendix is presented for only the analysis with the greatest overload.

It should be noted the generator contributions presented in the appendices sections are full contributions, whereas in the body of the report, those contributions take into consideration the commercial probability of each project.

Appendix 1

(DVP - DVP) The 6MTEAGLE-6CHARLV L 230 kV line (from bus 314765 to bus 314749 ckt 1) loads from 99.73% to 100.01% (**DC power flow**) of its emergency rating (662 MVA) for the single line contingency outage of 'DVP_P1-2: LN 2027-A'. This project contributes approximately 1.84 MW to the thermal violation.

CONTINGENCY 'DVP_P1-2: LN 2027-A'

OPEN BRANCH FROM BUS 314310 TO BUS 314322 CKT 1 /* 6JUDES F 230.00
 - 6MDLTHAN 230.00
 OPEN BRANCH FROM BUS 314310 TO BUS 314333 CKT 1 /* 6JUDES F 230.00
 - 6POWHATN 230.00
 OPEN BRANCH FROM BUS 314333 TO BUS 933500 CKT 1 /* 6POWHATN
 230.00 - AC2-165 TAP 230.00
 OPEN BUS 314310 /* ISLAND
 OPEN BUS 314333 /* ISLAND
 END

Bus Number	Bus Name	Full Contribution
315191	1BEARGRDN G1	14.44
315192	1BEARGRDN G2	14.44
315193	1BEARGRDN S1	29.71
315170	1BREMO 3	29.98
315171	1BREMO 4	65.87
315150	1BUGGS 1	7.2
315151	1BUGGS 2	7.2
315153	1CLOVER1	7.44
315154	1CLOVER2	7.35
315159	1KERR 2	0.85
315164	1KERR 7	0.84
314429	3JTRSVLE	0.61
932511	AC2-071 C	6.19
933501	AC2-165 C	37.8
934611	AD1-087 C O1	4.25
934621	AD1-088 C	14.57
935171	AD1-152 C O1	4.23
935221	AD1-157 C	2.33
935231	AD1-160 C	1.71
936261	AD2-033 C	12.87
936361	AD2-046 C O1	5.42
936481	AD2-063 C O1	14.27
936651	AD2-082 C	2.61
937461	AD2-200 C	1.84
937481	AD2-202 C O1	1.17

LTF	CARR	0.23
LTF	CBM-S1	2.61
LTF	CBM-S2	6.6
LTF	CBM-W1	3.45
LTF	CBM-W2	13.24
LTF	CIN	0.82
LTF	CPLE	2.15
LTF	IPL	0.52
LTF	LGEE	0.18
LTF	MEC	2.27
LTF	MECS	0.3
LTF	RENSSELAER	0.18
LTF	ROSETON	1.3
LTF	WEC	0.23
LTF	AA2-074	1.46
920291	AA2-127	3.16
924021	AB2-043 C O1	2.49
924031	AB2-045 C	1.08
924161	AB2-060 C O1	7.38
924301	AB2-077 C O1	1.54
924311	AB2-078 C O1	1.54
924321	AB2-079 C O1	1.54
924411	AB2-090 C	3.14
925221	AB2-176 C	1.29
925611	AC1-036 C	1.09
925831	AC1-062	0.08
926271	AC1-105 C	3.18
926451	AC1-116 C	0.63
926761	AC1-162 C	47.96