



**Generation Interconnection**  
**Combined Feasibility/System Impact Study Report**  
**for**  
**Queue Project AF1-027**  
**PLUMSTED 537 ENERGY STORAGE (CIRS)**  
**2 MW Capacity / 0 MW Energy**

January 2020

# Table of Contents

1	Introduction.....	3
2	Preface.....	3
3	General.....	4
3.1	Point of Interconnection .....	5
3.2	Cost Summary.....	5
4	Transmission Owner Scope of Work.....	5
5	Schedule.....	5
6	Transmission Owner Analysis.....	5
7	Interconnection Customer Requirements.....	6
7.1	System Protection.....	6
7.2	Compliance Issues and Interconnection Customer Requirements .....	6
8	Power Factor Requirements .....	7
9	Revenue Metering and SCADA Requirements .....	8
9.1	PJM Requirements .....	8
9.2	JCPL Requirements.....	8
10	Network Impacts.....	9
11	Generation Deliverability .....	11
12	Multiple Facility Contingency .....	11
13	Contribution to Previously Identified Overloads .....	11
14	Potential Congestion due to Local Energy Deliverability.....	11
15	System Reinforcements.....	12
16	Affected Systems .....	14
17	Short Circuit.....	16
18	Stability .....	18
19	Attachment One: One Line Diagram.....	19

## 1 Introduction

This Combined Feasibility/System Impact Study has been prepared in accordance with the PJM Open Access Transmission Tariff, 36.2, as well as the Feasibility Study Agreement between the Interconnection Customer (IC), and PJM Interconnection, LLC (PJM), Transmission Provider (TP). The Interconnected Transmission Owner (ITO) is Jersey Central Power and Light (JCPL).

## 2 Preface

The intent of the Combined Feasibility/System Impact study is to determine a plan, with ballpark cost and construction time estimates, to connect the subject generation to the PJM network at a location specified by the Interconnection Customer. The Interconnection Customer may request the interconnection of generation as a capacity resource or as an energy-only resource. As a requirement for interconnection, the Interconnection Customer may be responsible for the cost of constructing: (1) Direct Connections, which are new facilities and/or facilities upgrades needed to connect the generator to the PJM network, and (2) Network Upgrades, which are facility additions, or upgrades to existing facilities, that are needed to maintain the reliability of the PJM system.

In some instances a generator interconnection may not be responsible for 100% of the identified network upgrade cost because other transmission network uses, e.g. another generation interconnection, may also contribute to the need for the same network reinforcement. Cost allocation rules for network upgrades can be found in PJM Manual 14A, Attachment B. The possibility of sharing the reinforcement costs with other projects may be identified in the feasibility study, but the actual allocation will be deferred until the impact study is performed.

The Feasibility Study estimates do not include the feasibility, cost, or time required to obtain property rights and permits for construction of the required facilities. The project developer is responsible for the right of way, real estate, and construction permit issues. For properties currently owned by Transmission Owners, the costs may be included in the study.

### 3 General

The Interconnection Customer (IC) has proposed an uprate to a battery storage generating facility located in Monmouth County, New Jersey. This project is an increase to the Interconnection Customer's AA1-060 project, which will share the same property and point of interconnection. The AF1-027 queue position is a 2 MW Capacity-only uprate to the previous project. The total installed facilities will have a capability of 20 MW with 2 MW of this output being recognized by PJM as Capacity (see table below for clarity). The proposed in-service date for this uprate project was May 31, 2019. This study does not imply a TO commitment to this in-service date.

Queue	Maximum Facility Output (MFO) (MW)	Energy (MW)	Capacity (MW)
AA1-060	20	20	0
AF1-027	20	0	2
<b>Total</b>	<b>20</b>	<b>20</b>	<b>2</b>

Queue Number	AF1-027
Project Name	PLUMSTED 537 ENERGY STORAGE (CIRS)
State	New Jersey
County	Monmouth
Transmission Owner	JCPL
MFO	20
MWE	0
MWC	2
Fuel	Storage
Basecase Study Year	2023

### 3.1 Point of Interconnection

The interconnection of the project at the Primary POI will be accomplished by utilizing the Plumsted Battery (AA1-060) interconnection which is tapped from the Great Adventure Tap – Great Adventure 34.5 kV line in the JCPL area.

Attachment 1 shows a one-line diagram of the connection facilities for the AF1-027 generation project to connect to the FirstEnergy (“FE”) transmission system.

### 3.2 Cost Summary

The AF1-027 project will be responsible for the following costs:

Description	Total Cost
Attachment Facilities	\$0
Direct Connection Network Upgrade	\$0
Non Direct Connection Network Upgrades	\$0
Total Costs	\$0

No network upgrades are required to accommodate AF1-027:

Description	Total Cost
System Upgrades	\$0

## 4 Transmission Owner Scope of Work

No physical interconnection work is required for this Capacity-only uprate.

## 5 Schedule

No physical interconnection work is required for this Capacity-only uprate.

## 6 Transmission Owner Analysis

FE performed an analysis of its underlying transmission <100 kV system. The AF1-027 project did not contribute to any overloads on the FE transmission <100 kV system.

## 7 Interconnection Customer Requirements

### 7.1 System Protection

The IC must design its Customer Facilities in accordance with all applicable standards, including the standards in FE's "Requirements for Transmission Connected Facilities" document located at: <http://www.pjm.com/planning/design-engineering/to-tech-standards/private-firstenergy.aspx>. Preliminary Protection requirements will be provided as part of the Facilities Study. Detailed Protection Requirements will be provided once the project enters the construction phase.

### 7.2 Compliance Issues and Interconnection Customer Requirements

The proposed Customer Facilities must be designed in accordance with FE's "Requirements for Transmission Connected Facilities" document located at: <http://www.pjm.com/planning/design-engineering/to-tech-standards/private-firstenergy.aspx>. In particular, the IC is responsible for the following:

1. The purchase and installation of a fully rated 34.5 kV circuit breaker to protect the AF1-027 generator lead line. A single circuit breaker must be used to protect this line; if the project has several GSU transformers, the individual GSU transformer breakers cannot be used to protect this line.
2. The purchase and installation of the minimum required FE generation interconnection relaying and control facilities. This includes over/under voltage protection, over/under frequency protection, and zero sequence voltage protection relays.
3. The purchase and installation of supervisory control and data acquisition ("SCADA") equipment to provide information in a compatible format to the FE Transmission System Control Center.
4. Compliance with the FE and PJM generator power factor and voltage control requirements.
5. The execution of a back-up service agreement to serve the customer load supplied from the AF1-027 generation project metering point when the units are out-of-service. This assumes the intent of the IC is to net the generation with the load.

The IC will also be required to meet all PJM, ReliabilityFirst, and NERC reliability criteria and operating procedures for standards compliance. For example, the IC will need to properly locate and report the over and under voltage and over and under frequency system protection elements for its units as well as the submission of the generator model and protection data required to satisfy the PJM and ReliabilityFirst audits. Failure to comply with these requirements may result in a disconnection of service if the violation is found to compromise the reliability of the FE system.

## **8 Power Factor Requirements**

The IC shall design its non-synchronous Customer Facility with the ability to maintain a power factor of at least 0.95 leading (absorbing VARs) to 0.95 lagging (supplying VARs) measured at the high-side of the facility substation transformer(s) connected to the FE transmission system.

## 9 Revenue Metering and SCADA Requirements

### 9.1 PJM Requirements

The Interconnection Customer will be required to install equipment necessary to provide Revenue Metering (KWH, KVARH) and real time data (KW, KVAR) for IC's generating Resource. See PJM Manuals M-01 and M-14D, and PJM Tariff Section 8 of Attachment O.

### 9.2 JCPL Requirements

The IC will be required to comply with all FE revenue metering requirements for generation interconnection customers which can be found in FE's "Requirements for Transmission Connected Facilities" document located at: <http://www.pjm.com/planning/design-engineering/to-tech-standards/private-firstenergy.aspx>.

## 10 Network Impacts

The Queue Project AF1-027 was evaluated as a 2.0 MW (Capacity 2.0 MW) injection as an uprate to AA1-060 tapping the Hornerstown to the Great Adventure 34.5 kV line in the JCPL area. Project AF1-027 was evaluated for compliance with applicable reliability planning criteria (PJM, NERC, NERC Regional Reliability Councils, and Transmission Owners). Project AF1-027 was studied with a commercial probability of 100%. Potential network impacts were as follows:

# Summer Peak Load Flow

## 11 Generation Deliverability

(Single or N-1 contingencies for the Capacity portion only of the interconnection)

None

## 12 Multiple Facility Contingency

(Double Circuit Tower Line, Fault with a Stuck Breaker, and Bus Fault contingencies for the full energy output)

None

## 13 Contribution to Previously Identified Overloads

(This project contributes to the following contingency overloads, i.e. "Network Impacts", identified for earlier generation or transmission interconnection projects in the PJM Queue)

None

## 14 Potential Congestion due to Local Energy Deliverability

PJM also studied the delivery of the energy portion of this interconnection request. Any problems identified below are likely to result in operational restrictions to the project under study. The developer can proceed with network upgrades to eliminate the operational restriction at their discretion by submitting a Merchant Transmission Interconnection request.

Note: Only the most severely overloaded conditions are listed below. There is no guarantee of full delivery of energy for this project by fixing only the conditions listed in this section. With a Transmission Interconnection Request, a subsequent analysis will be performed which shall study all overload conditions associated with the overloaded element(s) identified.

None

## 15 System Reinforcements

None

—

## Affected Systems

## 16 Affected Systems

None

## Short Circuit

## 17 Short Circuit

The following Breakers are overduty:

None

# Stability

## 18 Stability

Not required for a Capacity-only update.

19 Attachment One: One Line Diagram

**AF1-027: Great Adventure 34.5 kV II – Plumsted 537 Energy Storage (CIRs)**

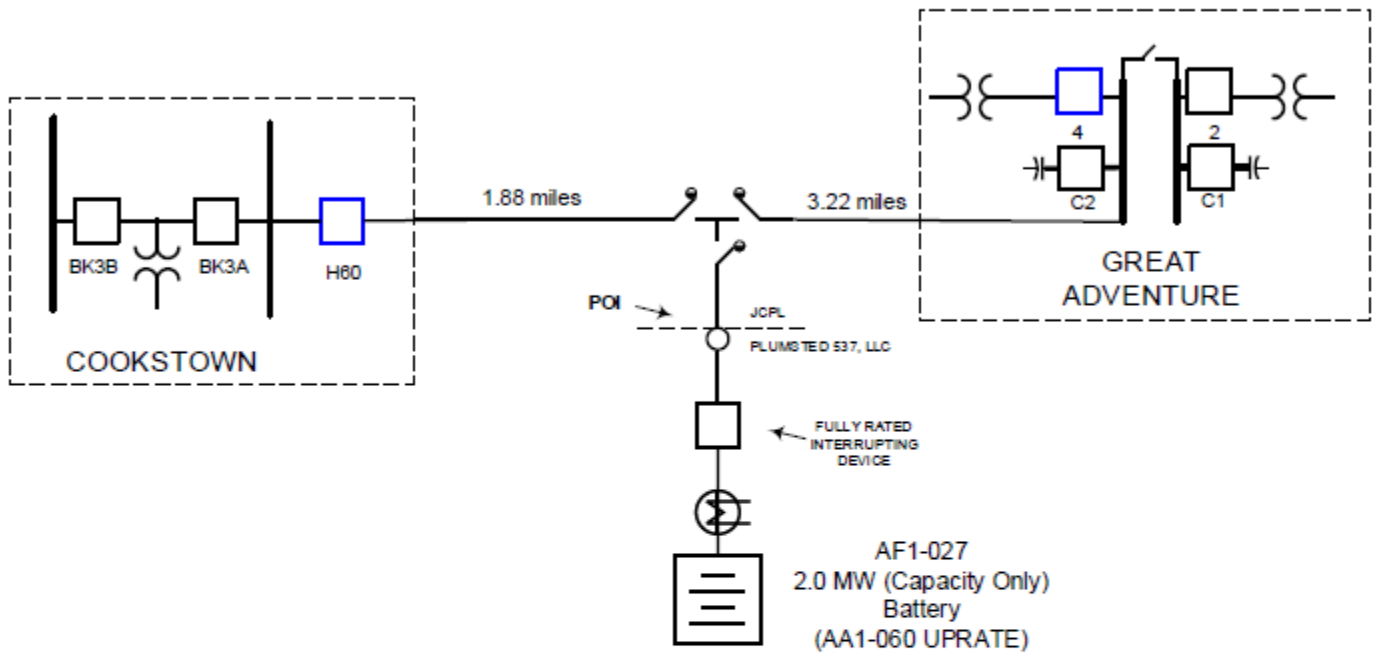

**Notes**

- Appropriate terminal equipment upgrades required to accommodate higher generation output.
- Review of relay settings at Cookstown and Great Adventure substations.

**Legend**

Existing JCPL Equipment	
New JCPL Equipment	
New Customer Equipment	