



**Generation Interconnection
Combined Feasibility and System Impact
Study Report
for
Queue Project AF1-192
MOUNTAIN 2 115 KV
1 MW Capacity / 1 MW Energy**

January 2020

Table of Contents

- 1 Introduction..... 4
- 2 Preface..... 4
- 3 General..... 6
 - 3.1 Point of Interconnection 6
 - 3.2 Cost Summary..... 6
- 4 Transmission Owner Scope of Work..... 7
- 5 Attachment Facilities 7
- 6 Direct Connection Cost Estimate..... 7
- 7 Non-Direct Connection Cost Estimate..... 7
- 8 Schedule..... 7
- 9 Transmission Owner Analysis..... 7
 - 9.1 Power Flow Analysis 7
- 10 Interconnection Customer Requirements..... 8
 - System Protection 8
 - Compliance Issues and Interconnection Customer Requirements..... 8
 - Power Factor Requirements 8
- 11 Revenue Metering and SCADA Requirements 9
 - 11.1 PJM Requirements 9
 - 11.2 ME Requirements..... 9
- 12 Network Impacts.....10
 - 12.1 Generation Deliverability12
 - 12.2 Multiple Facility Contingency12
 - 12.3 Contribution to Previously Identified Overloads.....12
 - 12.4 Potential Congestion due to Local Energy Deliverability.....12
- 13 Short Circuit.....14
- 14 Affected Systems16
 - 14.1 LG&E.....16
 - 14.2 MISO16
 - 14.3 TVA.....16
 - 14.4 Duke Energy Progress.....16
 - 14.5 NYISO16

15 Attachment 1 – One Line.....17

1 Introduction

This Feasibility Study has been prepared in accordance with the PJM Open Access Transmission Tariff, 36.2, as well as the Feasibility Study Agreement between, the Interconnection Customer (IC), and PJM Interconnection, LLC (PJM), Transmission Provider (TP). The Interconnected Transmission Owner (ITO) is Mid-Atlantic Interstate Transmission, LLC (MAIT), MetEd Zone.

2 Preface

The intent of the feasibility study is to determine a plan, with ballpark cost and construction time estimates, to connect the subject generation to the PJM network at a location specified by the Interconnection Customer. The Interconnection Customer may request the interconnection of generation as a capacity resource or as an energy-only resource. As a requirement for interconnection, the Interconnection Customer may be responsible for the cost of constructing: (1) Direct Connections, which are new facilities and/or facilities upgrades needed to connect the generator to the PJM network, and (2) Network Upgrades, which are facility additions, or upgrades to existing facilities, that are needed to maintain the reliability of the PJM system.

In some instances a generator interconnection may not be responsible for 100% of the identified network upgrade cost because other transmission network uses, e.g. another generation interconnection, may also contribute to the need for the same network reinforcement. Cost allocation rules for network upgrades can be found in PJM Manual 14A, Attachment B. The possibility of sharing the reinforcement costs with other projects may be identified in the feasibility study, but the actual allocation will be deferred until the impact study is performed.

PJM utilizes manufacturer models to ensure the performance of turbines is properly captured during the simulations performed for stability verification and, where applicable, for compliance with low voltage ride through requirements. Turbine manufacturers provide such models to their customers. The list of manufacturer models PJM has already validated is contained in Attachment B of Manual 14G. Manufacturer models may be updated from time to time, for various reasons such as to reflect changes to the control systems or to more accurately represent the capabilities turbines and controls which are currently available in the field. Additionally, as new turbine models are developed, turbine manufacturers provide such new models which must be used in the conduct of these studies. PJM needs adequate time to evaluate the new models in order to reduce delays to the System Impact Study process timeline for the Interconnection Customer as well as other Interconnection Customers in the study group. Therefore, PJM will require that any Interconnection Customer with a new manufacturer model must supply that model to PJM, along with a \$10,000 fully refundable deposit, no later than three (3) months prior to the starting date of the System Impact Study (See Section 4.3 for starting dates) for the Interconnection Request which shall specify the use of the new model. The Interconnection Customer will be required to submit a completed dynamic model study request form (Attachment B-1 of Manual 14G) in order to document the request for the study.

The Feasibility Study estimates do not include the feasibility, cost, or time required to obtain property rights and permits for construction of the required facilities. The project developer is responsible for the right of way, real estate, and construction permit issues. For properties currently owned by Transmission Owners, the costs may be included in the study.

3 General

The Interconnection Customer (IC), has proposed an increase to an existing Natural Gas generating facility located in Cumberland County, Mount Holly Springs, Pennsylvania. Note that this project is an increase to the Interconnection Customer's existing Mountain Unit 2, which will share the same property and connection point. This projects requests an increase to the installed capability of Mountain Unit 2 of 1 MW with 1 MW of this output being recognized by PJM as Capacity. The installed facilities will have a total capability of 28 MW with 21 MW of this output being recognized by PJM as Capacity. The proposed in-service date for this project is October 1, 2019. This study does not imply a TO commitment to this in-service date.

Queue Number	AF1-192
Project Name	MOUNTAIN 2 115 KV
State	Pennsylvania
County	Cumberland
Transmission Owner	MAIT (MetEd Zone)
MFO	28
MWE	1
MWC	1
Fuel	Natural Gas
Basecase Study Year	2023

3.1 Point of Interconnection

AF1-192 will interconnect with the MAIT transmission system (MetEd Zone) as an uprate to the Mountain Plant; Unit 2 at the Mountain CT 13.8 kV substation.

3.2 Cost Summary

The AF1-192 project will be responsible for the following costs:

Description	Total Cost
Attachment Facilities	\$0
Direct Connection Network Upgrade	\$0
Non Direct Connection Network Upgrades	\$0
Total Costs	\$0

In addition, the AF1-192 project may be responsible for a contribution to the following costs

None.

4 Transmission Owner Scope of Work

AF1-192 is an increase to the existing generators connected directly to the Mountain 115 kV substation. It is anticipated that there will be no direct connect costs associated with this project.

Attachment 1 shows a one-line diagram of the existing primary direct connection facilities for the AF1-192 generation project to connect to the FirstEnergy (“FE”) transmission system. IC will be responsible for constructing the facilities on its side of the POI, including the attachment facilities which connect the generator to the FE transmission system’s direct connection facilities.

5 Attachment Facilities

There is no Attachment Facility scope of work required.

6 Direct Connection Cost Estimate

There is no Direct Connection scope of work required.

7 Non-Direct Connection Cost Estimate

There is no Non-Direct Connection scope of work required.

8 Schedule

AF1-192 is an increase to the generation at the South Reading 69 kV substation. Therefore, there are no Attachment Facilities, Direct, and Non-Direct Connection facilities work to be completed outside of the scope of the AF1-192 project.

9 Transmission Owner Analysis

9.1 Power Flow Analysis

FE performed an analysis of its underlying transmission <100 kV system. The AF1-192 project did not contribute to any overloads on the FE transmission <100 kV system.

10 Interconnection Customer Requirements

System Protection

The IC must design its Customer Facilities in accordance with all applicable standards, including the standards in FE's "Requirements for Transmission Connected Facilities" document located at:

<http://www.pjm.com/planning/design-engineering/to-tech-standards/private-firstenergy.aspx>. Preliminary Protection requirements will be provided as part of the Facilities Study. Detailed Protection Requirements will be provided once the project enters the construction phase.

Compliance Issues and Interconnection Customer Requirements

The proposed Customer Facilities must be designed in accordance with FE's "Requirements for Transmission Connected Facilities" document located at: <http://www.pjm.com/planning/design-engineering/to-tech-standards/private-firstenergy.aspx>.

The IC will also be required to meet all PJM, ReliabilityFirst, and NERC reliability criteria and operating procedures for standards compliance. For example, the IC will need to properly locate and report the over and under voltage and over and under frequency system protection elements for its units as well as the submission of the generator model and protection data required to satisfy the PJM and ReliabilityFirst audits. Failure to comply with these requirements may result in a disconnection of service if the violation is found to compromise the reliability of the FE system.

Power Factor Requirements

The existing 28 MW portion of the Customer Facility shall retain its existing ability to maintain a power factor of at least 0.95 leading (absorbing VARs) to 0.90 lagging (supplying VARs) measured at the Point of Interconnection. The increase of 1.0 MW to the Customer Facilities associated with the AF1-192 project shall be designed with the ability to maintain a Power Factor of at least 1.0 (unity) to 0.90 lagging (supplying VARs) measured at the Point of Interconnection.

11 Revenue Metering and SCADA Requirements

11.1 PJM Requirements

The Interconnection Customer will be required to install equipment necessary to provide Revenue Metering (KWH, KVARH) and real time data (KW, KVAR) for IC's generating Resource. See PJM Manuals M-01 and M-14D, and PJM Tariff Section 8 of Attachment O.

11.2 MAIT Requirements

The IC will be required to comply with all FE revenue metering requirements for generation interconnection customers which can be found in FE's "Requirements for Transmission Connected Facilities" document located at: <http://www.pjm.com/planning/design-engineering/to-tech-standards/private-firstenergy.aspx>

12 Network Impacts

The Queue Project AF1-192 was evaluated as a 1.0 MW (Capacity 1.0 MW) injection as an uprate to the Mountain Plant Unit 2 at the Mountain CT 13.8 kV substation in the MAIT area, MetEd Zone. Project AF1-192 was evaluated for compliance with applicable reliability planning criteria (PJM, NERC, NERC Regional Reliability Councils, and Transmission Owners). Project AF1-192 was studied with a commercial probability of 1.00. Potential network impacts were as follows:

Summer Peak Load Flow

12.1 Generation Deliverability

(Single or N-1 contingencies for the Capacity portion only of the interconnection)

None

12.2 Multiple Facility Contingency

(Double Circuit Tower Line, Fault with a Stuck Breaker, and Bus Fault contingencies for the full energy output)

None

12.3 Contribution to Previously Identified Overloads

(This project contributes to the following contingency overloads, i.e. "Network Impacts", identified for earlier generation or transmission interconnection projects in the PJM Queue)

None

12.4 Potential Congestion due to Local Energy Deliverability

PJM also studied the delivery of the energy portion of this interconnection request. Any problems identified below are likely to result in operational restrictions to the project under study. The developer can proceed with network upgrades to eliminate the operational restriction at their discretion by submitting a Merchant Transmission Interconnection request.

Note: Only the most severely overloaded conditions are listed below. There is no guarantee of full delivery of energy for this project by fixing only the conditions listed in this section. With a Transmission Interconnection Request, a subsequent analysis will be performed which shall study all overload conditions associated with the overloaded element(s) identified.

None

Short Circuit

13 Short Circuit

The following Breakers are overdutied:

None

Affected Systems

14 Affected Systems

14.1 LG&E

LG&E Impacts to be determined during later study phases (as applicable).

14.2 MISO

MISO Impacts to be determined during later study phases (as applicable).

14.3 TVA

TVA Impacts to be determined during later study phases (as applicable).

14.4 Duke Energy Progress

Duke Energy Progress Impacts to be determined during later study phases (as applicable).

14.5 NYISO

NYISO Impacts to be determined during later study phases (as applicable).

15 Attachment 1 – One Line

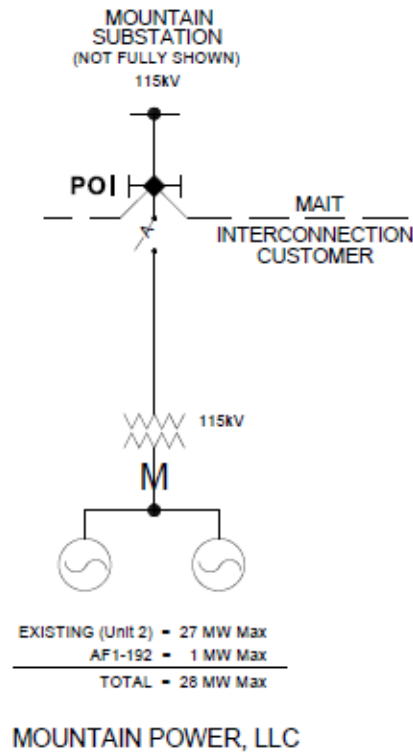

◆ = POI (POINT OF INTERCONNECTION) IS AT THE MAIT OWNED SUBSTATION DEAD-END STRUCTURE, WHERE INTERCONNECTION CUSTOMER'S TRANSMISSION LINE TERMINATES

M = REVENUE METERING FOR INTERCONNECTION CUSTOMER IS OWNED, OPERATED, AND MAINTAINED BY INTERCONNECTION CUSTOMER

 Energy Delivery Technical Services	TITLE			ID. 0	REV.
	MOUNTAIN POWER, LLC INTERCONNECTION TO THE MAIT OWNED MOUNTAIN 115kV SUBSTATION				
By JLM	DATE 02/06/2020	AGREEMENT	PO1-MAIT-ME-AF1-192		1
APR -	DISB PRELIMINARY				