



Generation Interconnection
Combined Feasibility / System Impact Study Report
for
Queue Project AF2-292
SOUTH UNION 138 KV
0 MW Capacity / 1.17 MW Energy

September 2020

Table of Contents

1	Introduction.....	4
2	Preface.....	4
3	General.....	5
4	Point of Interconnection.....	6
5	Cost Summary.....	6
6	Transmission Owner Scope of Work.....	7
6.1	FE Facility Upgrades and Costs.....	7
7	Schedule.....	8
8	Transmission Owner Analysis.....	8
8.1	Power Flow Analysis.....	8
8.2	Stability Analysis.....	8
8.3	Voltage Control.....	8
8.4	Short Circuit and Dynamics Analysis.....	9
8.5	Metering.....	9
9	Interconnection Customer Requirements.....	9
9.1	Compliance Issues.....	9
10	Revenue Metering and SCADA Requirements.....	10
10.1	PJM Requirements.....	10
10.2	Meteorological Data Reporting Requirements.....	10
10.3	Interconnected Transmission Owner Requirements – West Penn Power.....	10
11	Summer Peak - Load Flow Analysis.....	11
11.1	Generation Deliverability.....	12
11.2	Multiple Facility Contingency.....	12
11.3	Contribution to Previously Identified Overloads.....	12
11.4	Potential Congestion due to Local Energy Deliverability.....	12
11.5	System Reinforcements - Summer Peak Load Flow - Primary POI.....	13
11.6	Flow Gate Details.....	14
11.7	Queue Dependencies.....	14
11.8	Contingency Descriptions.....	15
12	Light Load Analysis.....	16
13	Short Circuit Analysis.....	16

13.1 System Reinforcements - Short Circuit.....16

14 Stability and Reactive Power16

15 Affected Systems16

16 Attachment 1: One Line Diagram17

1 Introduction

This Feasibility Study has been prepared in accordance with the PJM Open Access Transmission Tariff, 36.2, as well as the Feasibility Study Agreement between the Interconnection Customer (IC), and PJM Interconnection, LLC (PJM), Transmission Provider (TP). The Interconnected Transmission Owner (ITO) is West Penn Power, APS Zone.

2 Preface

The intent of the feasibility study is to determine a plan, with ballpark cost and construction time estimates, to connect the subject generation to the PJM network at a location specified by the Interconnection Customer. The Interconnection Customer may request the interconnection of generation as a capacity resource or as an energy-only resource. As a requirement for interconnection, the Interconnection Customer may be responsible for the cost of constructing: (1) Direct Connections, which are new facilities and/or facilities upgrades needed to connect the generator to the PJM network, and (2) Network Upgrades, which are facility additions, or upgrades to existing facilities, that are needed to maintain the reliability of the PJM system.

In some instances a generator interconnection may not be responsible for 100% of the identified network upgrade cost because other transmission network uses, e.g. another generation interconnection, may also contribute to the need for the same network reinforcement. Cost allocation rules for network upgrades can be found in PJM Manual 14A, Attachment B. The possibility of sharing the reinforcement costs with other projects may be identified in the feasibility study, but the actual allocation will be deferred until the impact study is performed.

The Interconnection Customer seeking to interconnect a wind or solar generation facility shall maintain meteorological data facilities as well as provide that meteorological data which is required per Schedule H to the Interconnection Service Agreement and Section 8 of Manual 14D.

The Feasibility Study estimates do not include the feasibility, cost, or time required to obtain property rights and permits for construction of the required facilities. The project developer is responsible for the right of way, real estate, and construction permit issues. For properties currently owned by Transmission Owners, the costs may be included in the study.

3 General

The Interconnection Customer (IC), has proposed a Solar; Storage generating facility located in Fayette County, Pennsylvania. The installed facilities will have a total capability of 1.17 MW with 0 MW of this output being recognized by PJM as Capacity. The proposed in-service date for this project is August 01, 2021. This study does not imply a TO commitment to this in-service date.

Queue Number	AF2-292
Project Name	SOUTH UNION 138 KV
State	Pennsylvania
County	Fayette
Transmission Owner	West Penn Power – APS
MFO	1.17
MWE	1.17
MWC	0
Fuel	Solar; Storage
Basecase Study Year	2023

Any new service customers who can feasibly be commercially operable prior to June 1st of the basecase study year are required to request interim deliverability analysis.

4 Point of Interconnection

AF2-292 will interconnect with the APS transmission system at the South Union 138 kV substation.

The POI for the Project will be accomplished by installing a new 12 kV terminal pole feeding to a gang operated switch at the current pole location near 403925-WP14 on the York Run 12 kV circuit out of South Union substation. The interconnection of the project at the Primary POI will be accomplished by tapping the York Run 12 kV line and constructing a one span tap. The distribution line tap will be located approximately 0.86 mile from South Union substation. The IC will be responsible for acquiring all easements, properties and permits that may be required to construct both the new 12kV line and the associated attachment facilities. A summary of the Project direct connection facilities that will be required for the POI and their estimated costs are shown in this document. The one-line for the POI is shown in Attachment 1.

5 Cost Summary

The AF2-292 project will be responsible for the following costs:

Description	Total Cost
Total Physical Interconnection Costs	\$82,000
Total System Network Upgrade Costs	\$0
Total Costs	\$82,000

This cost excludes a Federal Income Tax Gross Up charges. This tax may or may not be charged based on whether this project meets the eligibility requirements of IRS Notice 88-129. If at a future date it is determined that the Federal Income Tax Gross charge is required, the Transmission Owner shall be reimbursed by the Interconnection Customer for such taxes.

6 Transmission Owner Scope of Work

In compliance with the Regional Transmission Provider (PJM) protocol, the IC has submitted a "Form of System Impact Study Agreement" to PJM that identifies its plan to construct a solar generation to a 12 kV distribution line with a total capability of 1.166 MW. For purposes of this report, it has been designated as the York Run 12kV AF2-292 Project (hereinafter, the "Project") to reflect its interconnection voltage and its proximity to the South Union Substation. Attachment 1 shows an aerial view of the proposed primary direct connection facilities for the solar generation project to connect to the FirstEnergy ("FE") distribution system. This report contains detailed connection requirements, direct connection costs and schedule, power flow analysis, short circuit analysis, and a cost and schedule for any associated system reinforcements.

6.1 FE Facility Upgrades and Costs

Results of the West Penn Power Flow Analysis show no FE Planning Criteria thermal violations directly attributable to the Project but does show voltage violations. Therefore, the IC is responsible for the costs shown in the table below.

Note that all cost estimates contained in this document were produced with an engineering design based on current information. The IC will be responsible for the actual cost of the direct connection that is implemented. West Penn Power herein reserves the right to return to any issues in this document and, upon appropriate justification, request additional monies to complete any reinforcements to the distribution system.

The total physical interconnection costs is given in the table below:

Description	Total Cost
Install GOAB switch and 1 span tap to a 12.47 kV metering package	\$48,000
Change the LTC setting at South Union SS #61 bank. Replace 450 kVAR capacitor at pole 702582 with 900 kVAR. Remove 300 kVAR capacitor at pole 24348. Change phasing on several taps. SCADA connection.	\$34,000
Total Physical Interconnection Costs	\$82,000

7 Schedule

Based on the scope of work for the Attachment Facilities and the Direct and/or Non-Direct Connection facilities, it is expected to take a minimum of **12 months** after the signing of an Interconnection Construction Service Agreement to complete the installation. This includes the requirement for the IC to make a preliminary payment that compensates FE for the first three months of the engineering design work that is related to the construction of the interconnection substation. This assumes that there will be no environmental issues with any of the new properties associated with this project, that there will be no delays in acquiring the necessary permits for implementing the defined direct connection and network upgrades, and that all distribution system outages will be allowed when requested.

8 Transmission Owner Analysis

8.1 Power Flow Analysis

A Power Flow study was conducted to determine the reliability impact of the proposed Project on the West Penn Power distribution line and substation. This included the performance of a contingency analysis to identify any facility overload or voltage condition that violates the FE Planning Criteria. Any such violation that is either directly attributable to this project or for which it will have a shared responsibility is included in this report with a least cost plan identified to mitigate them.

The CYME Power Flow Analysis was performed using expected 2021 summer/winter peak load base case. The analysis performed by West Penn Power used a detailed representation of the West Penn Power 138kV and 12kV systems. A simulation of all possible contingencies in the area of the Project were analyzed to test for criteria compliance. After review, the solar system posed no overload problems to the circuit under either a maximum or minimum output generation but did pose voltage problems. However, these conditions can be mitigated with appropriate action. There was also no expected flow onto the 138kV source due to the normal loading on the transformer.

8.2 Stability Analysis

A dynamic stability analysis was completed by FE. There were no stability concerns identified for the system.

8.3 Voltage Control

Since this installation will have the ability to change load instantly based on the operation of the PV system the voltage fluctuation was studied during the normal operation of the system. The voltage fluctuation was studied using several combinations of the solar generation and load level. The maximum instantaneous change expected on the system at both the substation bus and POI is acceptable and the voltage regulator will correct the load changes within 1 minute to insure required steady state voltage.

8.4 Short Circuit and Dynamics Analysis

A short circuit analysis has been performed by West Penn Power. The findings show that no equipment is over-dutied with the addition of the Project. Since the inverter limits the fault current to 1 time the rating, all protective devices are acceptable.

8.5 Metering

The IC will be required to comply with all FE revenue metering requirements for generation interconnection customers. Drawings provided show metering at the POI and these meters must comply.

9 Interconnection Customer Requirements

The IC will be responsible for meeting all criteria as specified in the applicable sections of the Customer Interconnection Guide 3 Phase document.

9.1 Compliance Issues

The IC will be responsible for meeting all FE criteria as defined in the FE Requirements for Distribution Connected Facilities.

The IC must meet all PJM and NERC reliability criteria and operating procedures required for standards compliance.

West Penn Power requests a copy of relay settings to insure they meet the requirements of Section 6.0 of the Customer Interconnection Guide.

West Penn Power Regional Engineering requires a transformer configuration of wye grounded – wye grounded connection unless determined otherwise by West Penn Power Regional Engineering.

Section 7.1 of the Customer Interconnection Guide requires access via SCADA and will be required as spelled out as described in Section 7.1 of the Customer Interconnection Guide.

Section 9.0 of the Customer Interconnection Guide requires either pre-certification or acceptance testing to ensure compliance with IEEE 1547.1 Standard Conformance Test Procedure for Equipment Interconnecting Distributed Resources with Electric Power Systems. When Acceptance Testing is required, it must be performed by a third-party testing organization. West Penn Power must be notified of when the testing is to occur and have the option to attend.

In addition to the IC requirements identified in this report, the customer's interconnection must conform with all the requirements identified in IEEE Std. 1547-2018, unless a requirement has been specifically waived or altered, in writing, by The Company. The IC is advised to review all of the interconnection guidance provided in the document titled, [Customer Guide for Retail Interconnection of Electric Power Producing and Storage Facilities, Commercial/Industrial](#) located on the FirstEnergy/Company website for any additional requirements beyond those provided in IEEE-1547-2018. This guide is applicable to wholesale or retail interconnections.

10 Revenue Metering and SCADA Requirements

10.1 PJM Requirements

The Interconnection Customer will be required to install equipment necessary to provide Revenue Metering (KWH, KVARH) and real time data (KW, KVAR) for IC's generating Resource. See PJM Manuals M-01 and M-14D, and PJM Tariff Section 8 of Attachment O.

10.2 Meteorological Data Reporting Requirements

The solar generation facility shall provide the Transmission Provider with site-specific meteorological data including:

- Back Panel temperature (Fahrenheit)
- Irradiance (Watts/meter²)
- Ambient air temperature (Fahrenheit) – (Accepted, not required)
- Wind speed (meters/second) – (Accepted, not required)
- Wind direction (decimal degrees from true north) – (Accepted, not required)

10.3 Interconnected Transmission Owner Requirements – West Penn Power

The FirstEnergy Revenue Metering Requirements may be found in the FirstEnergy Requirements for Transmission Connected Facilities document located at the following links:

www.pjm.com/planning/design-engineering/to-tech-standards.aspx

11 Summer Peak - Load Flow Analysis

The Queue Project AF2-292 was evaluated as a 1.17 MW (Capacity 0.0 MW) injection at the South Union 138 kV substation in the APS area. Project AF2-292 was evaluated for compliance with applicable reliability planning criteria (PJM, NERC, NERC Regional Reliability Councils, and Transmission Owners). Project AF2-292 was studied with a commercial probability of 100.0 %. Potential network impacts were as follows:

11.1 Generation Deliverability

(Single or N-1 contingencies for the Capacity portion only of the interconnection)

None.

11.2 Multiple Facility Contingency

(Double Circuit Tower Line, Fault with a Stuck Breaker, and Bus Fault contingencies for the full energy output)

None.

11.3 Contribution to Previously Identified Overloads

(This project contributes to the following contingency overloads, i.e. "Network Impacts", identified for earlier generation or transmission interconnection projects in the PJM Queue)

None.

11.4 Potential Congestion due to Local Energy Deliverability

PJM also studied the delivery of the energy portion of this interconnection request. Any problems identified below are likely to result in operational restrictions to the project under study. The developer can proceed with network upgrades to eliminate the operational restriction at their discretion by submitting a Merchant Transmission Interconnection request.

Note: Only the most severely overloaded conditions are listed below. There is no guarantee of full delivery of energy for this project by fixing only the conditions listed in this section. With a Transmission Interconnection Request, a subsequent analysis will be performed which shall study all overload conditions associated with the overloaded element(s) identified.

None.

11.5 System Reinforcements - Summer Peak Load Flow - Primary POI

None.

11.6 Flow Gate Details

The following indices contain additional information about each facility presented in the body of the report. For each index, a description of the flowgate and its contingency was included for convenience. The intent of the indices is to provide more details on which projects/generators have contributions to the flowgate in question. All New Service Queue Requests, through the end of the Queue under study, that are contributors to a flowgate will be listed in the indices. Please note that there may be contributors that are subsequently queued after the queue under study that are not listed in the indices. Although this information is not used "as is" for cost allocation purposes, it can be used to gage the impact of other projects/generators. It should be noted the project/generator MW contributions presented in the body of the report are Full MW Impact contributions which are also noted in the indices column named "Full MW Impact", whereas the loading percentages reported in the body of the report, take into consideration the PJM Generator Deliverability Test rules such as commercial probability of each project as well as the ramping impact of "Adder" contributions. The MW Impact found and used in the analysis is shown in the indices column named "Gendeliv MW Impact".

—

None.

11.7 Queue Dependencies

The Queue Projects below are listed in one or more indices for the overloads identified in your report. These projects contribute to the loading of the overloaded facilities identified in your report. The percent overload of a facility and cost allocation you may have towards a particular reinforcement could vary depending on the action of these earlier projects. The status of each project at the time of the analysis is presented in the table. This list may change as earlier projects withdraw or modify their requests.

None.

11.8 Contingency Descriptions

None.

12 Light Load Analysis

No Impacts.

13 Short Circuit Analysis

The following Breakers are overdutied:

None.

13.1 System Reinforcements - Short Circuit

None.

14 Stability and Reactive Power

No Impacts.

15 Affected Systems

None.

16 Attachment 1: One Line Diagram

Line Tap on 12.47kV, at approx 39.851, -79.758 approx 4.71 from Sub on Richland 12.47 kV

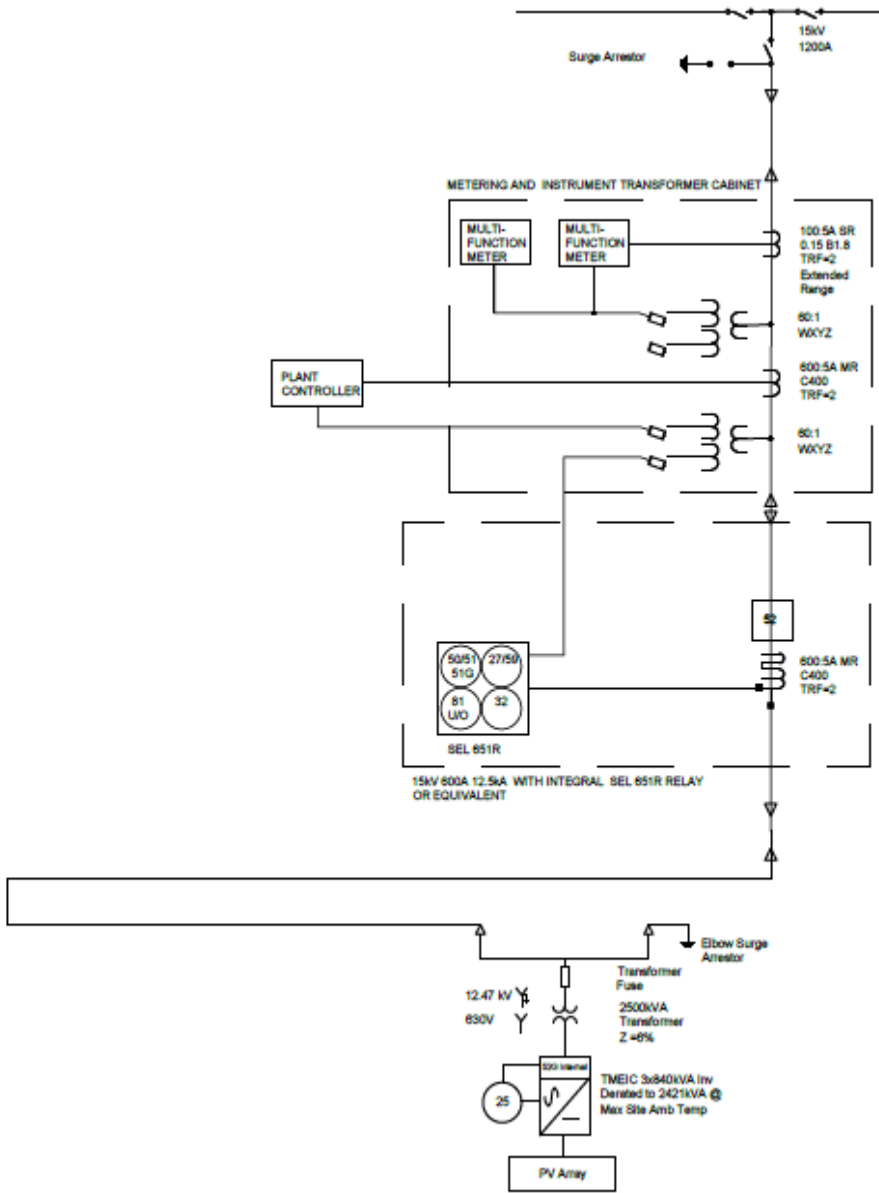

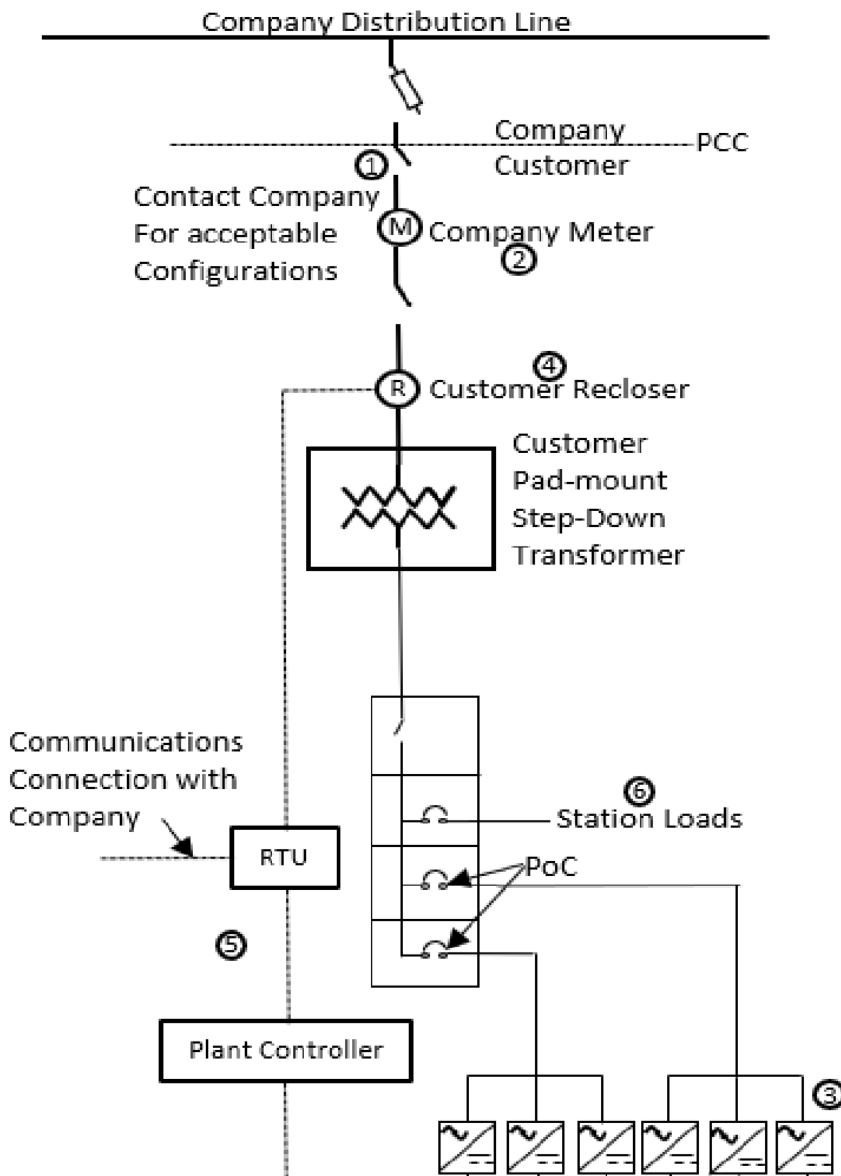

Notes:

1. Lockable disconnect switch with a visible open is required to be installed outdoors near the Company meter, or electric service point.
2. No Customer connections are permitted in the Company meter equipment area
3. UL-1741 listed inverters meeting the requirements of IEEE-1547. Adjustable settings are to be as defined in Table 2, or as specified by the Company
4. Recloser with integral , or external multi-function relay required if inverter rating 300 kW, or larger
5. RTU and optional plant controller required for SCADA, 1000 kW, or larger
6. Contact Company for metering and service requirements