



Generation Interconnection

Combined Feasibility / System Impact Study Report

for

Queue Project AF2-429

SOUTH HAMBURG 34.5 KV

0 MW Capacity / 3.72 MW Energy

February 2020

Table of Contents

1	Introduction.....	4
2	Preface.....	4
3	General.....	5
4	Point of Interconnection.....	6
5	Cost Summary.....	6
6	Transmission Owner Scope of Work.....	8
7	Schedule.....	9
8	Transmission Owner Analysis.....	9
8.1	Power Flow Analysis.....	9
8.2	Normal Circuit Configurations:.....	9
8.3	Abnormal Circuit Configurations:.....	9
9	Interconnection Customer Requirements.....	9
9.1	System Protection.....	9
9.2	Compliance Issues and Interconnection Customer Requirements.....	10
9.3	Power Factor Requirements.....	10
10	Revenue Metering and SCADA Requirements.....	11
10.1	PJM Requirements.....	11
10.2	Meteorological Data Reporting Requirements.....	11
10.3	ME Requirements.....	11
11	Summer Peak Analysis.....	12
11.1	Generation Deliverability.....	12
11.2	Multiple Facility Contingency.....	12
11.3	Contribution to Previously Identified Overloads.....	12
11.4	Steady-State Voltage Requirements.....	12
11.5	Potential Congestion due to Local Energy Deliverability.....	12
11.6	System Reinforcements.....	13
11.7	Flow Gate Details.....	14
11.8	Queue Dependencies.....	15
11.9	Contingency Descriptions.....	16
12	Light Load Analysis.....	17
13	Short Circuit Analysis.....	17

14	System Reinforcements - Short Circuit None	17
15	Stability and Reactive Power	18
16	Affected Systems	18
17	Attachment 1: One Line Diagram	19

1 Introduction

This System Impact Study has been prepared in accordance with the PJM Open Access Transmission Tariff, 205, as well as the System Impact Study Agreement between the Interconnection Customer (IC), and PJM Interconnection, LLC (PJM), Transmission Provider (TP). The Interconnected Transmission Owner (ITO) is Mid-Atlantic Interstate Transmission, LLC (MAIT) (Meted zone).

2 Preface

The intent of the System Impact Study is to determine a plan, with approximate cost and construction time estimates, to connect the subject generation interconnection project to the PJM network at a location specified by the Interconnection Customer. As a requirement for interconnection, the Interconnection Customer may be responsible for the cost of constructing: Network Upgrades, which are facility additions, or upgrades to existing facilities, that are needed to maintain the reliability of the PJM system. All facilities required for interconnection of a generation interconnection project must be designed to meet the technical specifications (on PJM web site) for the appropriate transmission owner.

In some instances an Interconnection Customer may not be responsible for 100% of the identified network upgrade cost because other transmission network uses, e.g. another generation interconnection or merchant transmission upgrade, may also contribute to the need for the same network reinforcement. The possibility of sharing the reinforcement costs with other projects may be identified in the Feasibility Study, but the actual allocation will be deferred until the System Impact Study is performed.

The System Impact Study estimates do not include the feasibility, cost, or time required to obtain property rights and permits for construction of the required facilities. The project developer is responsible for the right of way, real estate, and construction permit issues. For properties currently owned by Transmission Owners, the costs may be included in the study.

The Interconnection Customer seeking to interconnect a wind or solar generation facility shall maintain meteorological data facilities as well as provide that meteorological data which is required per Schedule H to the Interconnection Service Agreement and Section 8 of Manual 14D.

3 General

The Interconnection Customer (IC), has proposed a Solar; Storage generating facility located in Berks County, Pennsylvania. The installed facilities will have a total capability of 3.72 MW with 0 MW of this output being recognized by PJM as Capacity. The proposed in-service date for this project is August 01, 2021. This study does not imply a TO commitment to this in-service date.

Queue Number	AF2-429
Project Name	SOUTH HAMBURG 34.5 KV
State	Pennsylvania
County	Berks
Transmission Owner	ME
MFO	3.7
MWE	3.72
MWC	0
Fuel	Solar; Storage
Basecase Study Year	2023

Any new service customers who can feasibly be commercially operable prior to June 1st of the basecase study year are required to request interim deliverability analysis.

4 Point of Interconnection

AF2-429 will interconnect with the Met-Ed distribution system. The interconnection of the project at the proposed Primary POI will be accomplished by tapping the South Hamburg, 34.5 kV, 801-1 line near pole 50262-42720 and constructing a one span tap. The distribution line tap will be located approximately 6.1 miles from South Hamburg substation. The IC will be responsible for acquiring all easements, properties, and permits that may be required to construct both the new interconnection line tap and the associated attachment facilities. The project will also require non-direct connection upgrades at South Hamburg substation and on the 34.5 kV distribution circuit.

There are existing planned utility upgrades for the South Hamburg 801-1 circuit which impact the proposed AF2-429 project. The customer will not be able to connect until the planned utility upgrades are complete. Costs provided in this report are not impacted by the planned utility upgrades.

Attachment 1 shows a one-line diagram of the proposed primary direct connection facilities for the AF2-429 generation project to connect to the FirstEnergy (“FE”) transmission system. IC will be responsible for constructing the facilities on its side of the POI, including the attachment facilities which connect the generator to the Met-Ed transmission system’s direct connection facilities.

5 Cost Summary

The AF2-429 project will be responsible for the following costs:

Description	Total Cost
Total Physical Interconnection Costs	\$1,456,200
Allocation towards System Network Upgrade Costs	\$0
Total Costs	\$

This cost excludes a Federal Income Tax Gross Up charges. This tax may or may not be charged based on whether this project meets the eligibility requirements of IRS Notice 88-129. If at a future date it is determined that the Federal Income Tax Gross charge is required, the Transmission Owner shall be reimbursed by the Interconnection Customer for such taxes.

Note 1: PJM Open Access Transmission Tariff (OATT) section 217.3A outline cost allocation rules. The rules are further clarified in PJM Manual 14A Attachment B. The allocation of costs for a network upgrade will start with the first Queue project to cause the need for the upgrade. Later queue projects will receive cost allocation contingent on their contribution to the violation and are allocated to the queues that have not closed less than 5 years following the execution of the first Interconnection Service Agreement which identifies the need for this upgrade.

Note 2: For customers with System Reinforcements listed: If your present cost allocation to a System Reinforcement indicates \$0, then please be aware that as changes to the interconnection process occur, such as prior queued projects withdrawing from the queue, reducing in size, etc, the cost responsibilities can change and a cost allocation may be assigned to your project. In addition, although your present cost allocation to a System Reinforcement is presently \$0, your project may need this system reinforcement completed to be deliverable to the PJM system. If your project comes into service prior to completion of the system reinforcement, an interim deliverability study for your project will be required.

6 Transmission Owner Scope of Work

AF2-429 will interconnect with the Met-Ed distribution system. The interconnection of the project at the proposed Primary POI will be accomplished by tapping the South Hamburg, 34.5 kV, 801-1 line near pole 50262-42720 and constructing a one span tap. The distribution line tap will be located approximately 6.1 miles from South Hamburg substation. The IC will be responsible for acquiring all easements, properties, and permits that may be required to construct both the new interconnection line tap and the associated attachment facilities. The project will also require non-direct connection upgrades at South Hamburg substation and on the 34.5 kV distribution circuit.

There are existing planned utility upgrades for the South Hamburg 801-1 circuit which impact the proposed AF2-429 project. The customer will not be able to connect until the planned utility upgrades are complete. Costs provided in this report are not impacted by the planned utility upgrades.

Attachment 1 shows a one-line diagram of the proposed primary direct connection facilities for the AF2-429 generation project to connect to the FirstEnergy (“FE”) transmission system. Attachment 2 provides the proposed location for the point of interconnection. IC will be responsible for constructing the facilities on its side of the POI, including the attachment facilities which connect the generator to the Met-Ed transmission system’s direct connection facilities.

The total physical interconnection costs is given in the table below:

Description	Total Cost
Tap 34.5 kV circuit	\$24,000
Metering	\$39,000
Recloser	\$74,000
Upgrade upstream protective devices – GENERATION Related	\$157,000
Upgrade Single phase to Three phase construction (4400 ft) to POI – GENERATION Related	\$852,000
Direct Transfer Trip Scheme – GENERATION Related	\$310,200
Total Physical Interconnection Costs	\$1,456,200

7 Schedule

Based on the scope of work for the interconnection facilities, it is expected to take a minimum of 8 months after the signing of an Interconnection Agreement and construction kickoff call to complete the installation. This assumes that there will be no environmental issues with any of the new properties associated with this project, that there will be no delays in acquiring the necessary permits for implementing the defined direct connection and network upgrades, and that all transmission system outages will be allowed when requested.

8 Transmission Owner Analysis

8.1 Power Flow Analysis

FE performed an analysis of its underlying transmission <100 kV system. The AF2-429 project did not contribute to any overloads on the FE transmission <100 kV system.

Met-Ed performed an analysis of the 34.5 kV distribution system for both generation and battery charging scenarios.

8.2 Normal Circuit Configurations:

Generation:

Under normal circuit configurations, the AF2-429 project did not contribute to any overloads or voltage flicker violations on the Met-Ed distribution system.

Battery Charging:

Under normal circuit configurations, the AF2-429 project did not contribute to any overloads or voltage flicker violations on the Met-Ed distribution system.

8.3 Abnormal Circuit Configurations:

Under abnormal circuit configurations, the AF2-429 project results in reasonable cause for concern for voltage flicker violations on the Met-Ed distribution system. FirstEnergy may require the installation of a PQ monitoring system to permit ongoing assessment of compliance with these criteria.

9 Interconnection Customer Requirements

9.1 System Protection

The IC must design its Customer Facilities in accordance with all applicable standards, including the standards in FE's "Requirements for Distribution Connected Facilities" document located at: <http://www.pjm.com/planning/design-engineering/to-tech-standards/private-firstenergy.aspx>.

Preliminary Protection requirements will be provided as part of the Facilities Study. Detailed Protection Requirements will be provided once the project enters the construction phase.

9.2 Compliance Issues and Interconnection Customer Requirements

The proposed Customer Facilities must be designed in accordance with FE's "Requirements for Distribution Connected Facilities" document located at: <http://www.pjm.com/planning/design-engineering/to-tech-standards/private-firstenergy.aspx>. In particular, the IC is responsible for the following:

The purchase and installation of a fully rated 34.5 kV circuit breaker to protect the AF2-429 generator lead line. A single circuit breaker must be used to protect this line; if the project has several GSU transformers, the individual GSU transformer breakers cannot be used to protect this line.

The purchase and installation of the minimum required FE generation interconnection relaying and control facilities. This includes over/under voltage protection, over/under frequency protection, and zero sequence voltage protection relays.

The purchase and installation of supervisory control and data acquisition ("SCADA") equipment to provide information in a compatible format to the FE Transmission System Control Center.

Compliance with the FE and PJM generator power factor and voltage control requirements.

The execution of a back-up service agreement to serve the customer load supplied from the AF2-429 generation project metering point when the units are out-of-service. This assumes the intent of the IC is to net the generation with the load.

The IC will also be required to meet all PJM, ReliabilityFirst, and NERC reliability criteria and operating procedures for standards compliance. For example, the IC will need to properly locate and report the over and under voltage and over and under frequency system protection elements for its units as well as the submission of the generator model and protection data required to satisfy the PJM and ReliabilityFirst audits. Failure to comply with these requirements may result in a disconnection of service if the violation is found to compromise the reliability of the FE system.

9.3 Power Factor Requirements

The IC shall design its solar-powered, non-synchronous Customer Facility with the ability to maintain a power factor of at least 0.95 leading (absorbing VARs) to 0.95 lagging (supplying VARs) measured at the high-side of the facility substation transformer(s) connected to the Met-Ed distribution system.

If high voltage, low voltage, or objectionable voltage flicker arises due to the operation, frequent tripping, and/or frequent starting and stopping of the generator, the generator owner may be required to disconnect its generation equipment from the FirstEnergy system until the problem has been fully investigated and resolved.

10 Revenue Metering and SCADA Requirements

10.1 PJM Requirements

The Interconnection Customer will be required to install equipment necessary to provide Revenue Metering (KWH, KVARH) and real time data (KW, KVAR) for IC's generating Resource. See PJM Manuals M-01 and M-14D, and PJM Tariff Section 8 of Attachment O.

10.2 Meteorological Data Reporting Requirements

The solar generation facility shall provide the Transmission Provider with site-specific meteorological data including:

- Back Panel temperature (Fahrenheit)
- Irradiance (Watts/meter²)
- Ambient air temperature (Fahrenheit) – (Accepted, not required)
- Wind speed (meters/second) – (Accepted, not required)

Wind direction (decimal degrees from true north) – (Accepted, not required)

10.3 ME Requirements

The IC will be required to comply with all FE revenue metering requirements for generation interconnection customers which can be found in FE's "Generation Interconnection Technical Requirements for Distribution Connected Facilities" document located at:

<http://www.pjm.com/planning/design-engineering/to-tech-standards/private-firstenergy.aspx>

11 Summer Peak Analysis

The Queue Project AF2-429 was evaluated as a 3.7 MW (Capacity 0.0 MW) injection at the South Hamburg 34.5 kV substation in the ME area. Project AF2-429 was evaluated for compliance with applicable reliability planning criteria (PJM, NERC, NERC Regional Reliability Councils, and Transmission Owners). Project AF2-429 was studied with a commercial probability of 100.0 %. Potential network impacts were as follows:

11.1 Generation Deliverability

(Single or N-1 contingencies for the Capacity portion only of the interconnection)

None

11.2 Multiple Facility Contingency

(Double Circuit Tower Line, Fault with a Stuck Breaker, and Bus Fault contingencies for the full energy output)

None

11.3 Contribution to Previously Identified Overloads

(This project contributes to the following contingency overloads, i.e. "Network Impacts", identified for earlier generation or transmission interconnection projects in the PJM Queue)

None

11.4 Steady-State Voltage Requirements

To be determined

11.5 Potential Congestion due to Local Energy Deliverability

PJM also studied the delivery of the energy portion of this interconnection request. Any problems identified below are likely to result in operational restrictions to the project under study. The developer can proceed with network upgrades to eliminate the operational restriction at their discretion by submitting a Merchant Transmission Interconnection request.

Note: Only the most severely overloaded conditions are listed below. There is no guarantee of full delivery of energy for this project by fixing only the conditions listed in this section. With a Transmission Interconnection Request, a subsequent analysis will be performed which shall study all overload conditions associated with the overloaded element(s) identified.

None

11.6 System Reinforcements

No transmission system impacts.

11.7 Flow Gate Details

The following indices contain additional information about each facility presented in the body of the report. For each index, a description of the flowgate and its contingency was included for convenience. The intent of the indices is to provide more details on which projects/generators have contributions to the flowgate in question. All New Service Queue Requests, through the end of the Queue under study, that are contributors to a flowgate will be listed in the indices. Please note that there may be contributors that are subsequently queued after the queue under study that are not listed in the indices. Although this information is not used "as is" for cost allocation purposes, it can be used to gage the impact of other projects/generators. It should be noted the project/generator MW contributions presented in the body of the report are Full MW Impact contributions which are also noted in the indices column named "Full MW Impact", whereas the loading percentages reported in the body of the report, take into consideration the PJM Generator Deliverability Test rules such as commercial probability of each project as well as the ramping impact of "Adder" contributions. The MW Impact found and used in the analysis is shown in the indices column named "Gendeliv MW Impact".

None

—

11.8 Queue Dependencies

The Queue Projects below are listed in one or more indices for the overloads identified in your report. These projects contribute to the loading of the overloaded facilities identified in your report. The percent overload of a facility and cost allocation you may have towards a particular reinforcement could vary depending on the action of these earlier projects. The status of each project at the time of the analysis is presented in the table. This list may change as earlier projects withdraw or modify their requests.

None

11.9 Contingency Descriptions

None

12 Light Load Analysis

Not required for this project.

13 Short Circuit Analysis

The following Breakers are overdutied

None

14 System Reinforcements - Short Circuit

None

15 Stability and Reactive Power

(Summary of the VAR requirements based upon the results of the dynamic studies)

No Impacts.

16 Affected Systems

None

17 Attachment 1: One Line Diagram

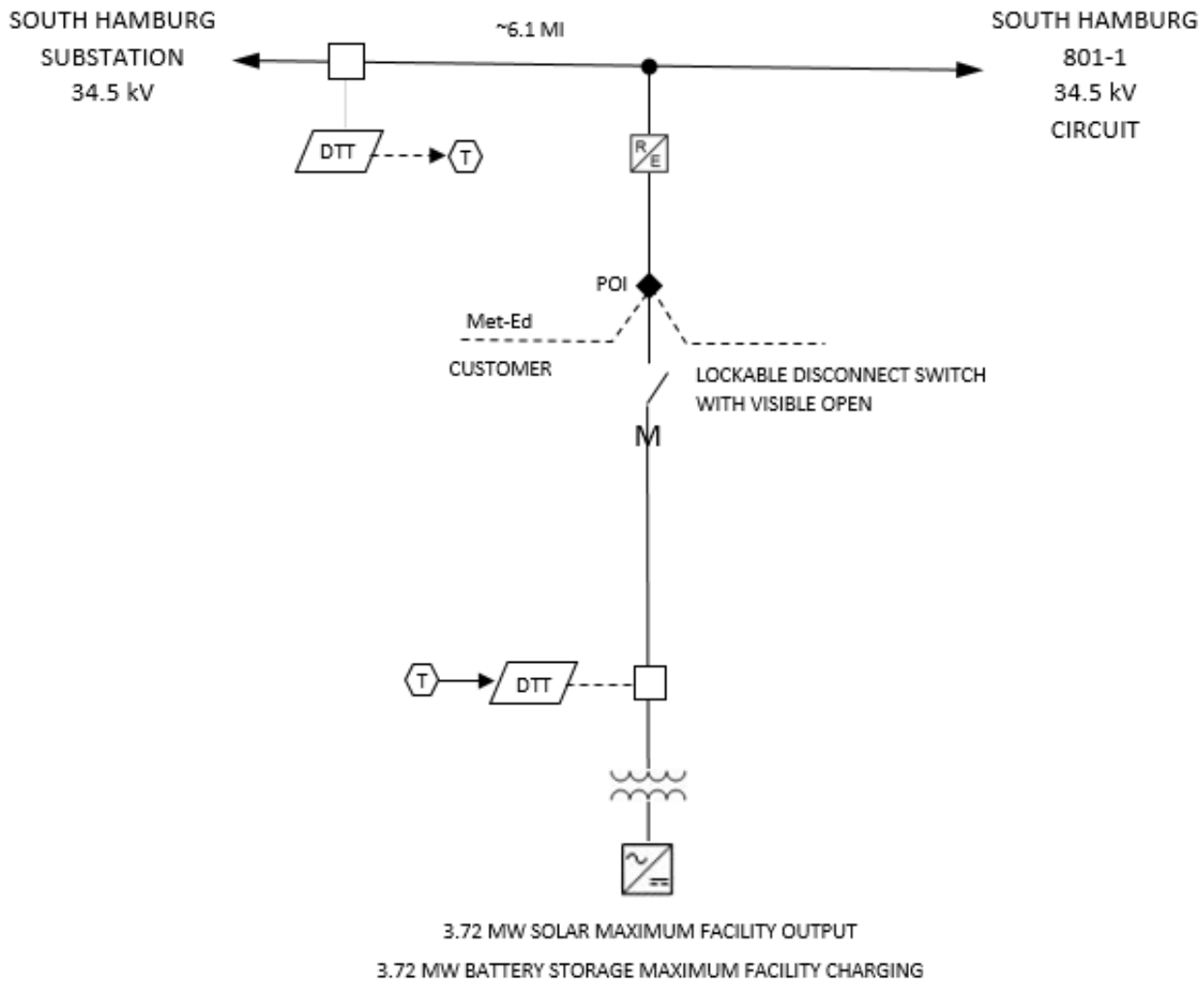

◆ = POI (POINT OF INTERCONNECTION) LOCATED NEAR 40.491652°, -75.942445°, WHERE CUSTOMER'S LINE TERMINATES

M = REVENUE METERING FOR INTERCONNECTION CUSTOMER IS OWNED, OPERATED, AND MAINTAINED BY INTERCONNECTION CUSTOMER