

Generation Interconnection

This analysis was completed to assess the reliability impact for a new generator interconnecting to the PJM system as a capacity resource.

Network Impacts -525 MW Injection into the Wayne-Homer City 345kV transmission

Potential network impacts for the injection of 525 MW into the Wayne-Homer City 345 kV transmission line were evaluated for summer peak conditions in 2004. The analysis performed for this project included a revised breaker configuration at the Erie West 345 kV as shown in Figure #2.

The system, as planned, was evaluated for compliance with reliability criteria. The results are summarized below.

Normal System

1. Overload on Eclipse – Clark Summit 115 kV was observed. The new generator contributes 19 MW to the overload.
2. Overload on the Westfall 115/46 kV transformer. The new generator contributes 2 MW to the overload.
3. Overload on the Blairsville 138/115 kV transformer. The new generator contributes 7 MW to the overload.

Single Contingency (MAAC Criteria IIA)

4. Voltage drops exceed 5% at Juniata 500 kV substation for the outage of the Hunterstown – Conastone 500 kV circuit and the Hunterstown 500/230 kV #1 transformer.
5. Overload on Keystone 500/230 kV #2 transformer for the outage of Keystone 500/230 kV #1 transformer. The new generator contributes 100 MW to the overload.
6. Overload on Homer City 345/230 kV #2 transformer for the outage of Homer City 345/230 kV #1 transformer. The new generator contributes 130 MW to the overload.
7. Overload on the Homer City – Shelocta 230 kV circuit and the Shelocta – Keystone 230 kV circuit for the outage of the Erie West – Ashtabula – Perry 345 kV circuit. This overload occurs even with the new Erie West 345 kV substation reconfiguration. The new generator contributes 170 MW to the overload.
8. Overload on the Erie South 345/230 kV #1 transformer for the outage of the Erie West – Ashtabula – Perry 345 kV circuit. This overload occurs even with the

new Erie West 345 kV substation reconfiguration. The new generator contributes 150 MW to the overload.

9. Overloads on the Utica Junction – Eclipse 115 kV circuit and the Eclipse – Clark Summit 115 kV circuit for the outage of the Erie West – Ashtabula – Perry 345 kV circuit. These overloads occur even with the new Erie West 345 kV substation reconfiguration. The new generator contributes 70 MW to the overload.

10. Overload on the Erie South 345/230 kV #1 transformer for the outage of the Erie West – Ashtabula – Perry 345 kV circuit and Erie West 345/115 kV #1 transformer. The new generator contributes 170 MW to the overload. This overload was previously identified for an earlier queued generator interconnection project (A38), and is what necessitates some of the Erie West substation upgrades.

Multiple Facility Contingency (MAAC Criteria IIC)

11. Overload on the Homer City 345/230 kV #2 transformer for the line fault with stuck breaker condition involving the outage of the Homer City – Stolle Road 345 kV circuit and Homer City 345/230 kV #1 transformer. The new generator contributes 140 MW to the overload. This overload was previously identified for an earlier queued generator interconnection project (B05), and is what necessitates the additional 345 kV breaker at Homer City. The overload is eliminated with the additional breaker at Homer City.

12. Overload on Homer City 345/230 kV #2 transformer for the line fault with stuck breaker condition involving the outage of the Homer City – Watercure 345 kV circuit and Homer City 345/230 kV #1 transformer. The new generator contributes 150 MW to the overload. This overload was previously identified for an earlier queued generator interconnection project (A38), and is what necessitates the additional 345 kV breaker at Homer City. The overload is eliminated with the additional breaker at Homer City.

Short Circuit Analysis

13. Multiple 345 kV and 230 kV circuit breakers are close to being overdutied when the required reinforcements at Homer City are installed. The exact number of circuit breakers which must be replaced will be dependent upon the 500/345 kV transformer impedance's and on more exact generator impedance characteristics.

System Reinforcements

The following reinforcements are required to eliminate network problems specified above:

- A. To eliminate the overload on the Eclipse - Clark Summit circuit, problems 1 and part of 9, terminal equipment at each end of the line will be upgraded. The estimated cost for this circuit is \$.5 million and the estimated time to construct is 1 year.
- B. To eliminate the overload on the Westfall transformer, problem 2, the transformer will be replaced with a transformer with a higher rating. The estimated cost for the installation of the new transformer is \$0.7 million and estimated time to complete is 2 years.
- C. To eliminate the overload on the Blairsville transformer, problem 3, a series reactor will be installed at Blairsville to limit the flow through the transformer. The estimated cost for the installation is \$1.5 million and estimated time to complete is 2 years.
- D. To eliminate the excessive voltage drops at the Juniata 500 kV substation, problem 4, a 350 MVAR SVC (Static Var Control) will be installed at the Juniata 500 kV substation. The estimated cost for the installation is \$14.5 million and the estimated time to complete is 1.5 years. The estimate does not include the cost of land to expand the substation.
- E. To eliminate the overloads described as problems 5, 6, 7 and 8 above, a three breaker 500 kV substation will be built at Homer City to provide two positions for termination of the present Keystone-Conemaugh 500 kV circuit and a position for a 500/345kV transformer. The 500kV substation is estimated to cost \$9 million and the transformer and connections into the 345 kV substation is estimated at \$5 million. Rerouting of the 500 kV Keystone-Conemaugh circuit into Homer City is estimated to cost \$1.8 million. Total estimated cost for this work is \$15.8 million and the estimated time to complete is 3 to 4 years. See Attachment 3.
- F. Overloads on the Utica Junction - Eclipse circuit described in 9 above will be alleviated by replacement of terminal equipment to increase the rating. The estimated cost of the upgrade is \$0.1 million and the estimated time to complete is 1 year.
- G. The overload on the Erie South transformer described in 10 above will be alleviated by the rearrangement of the Erie West substation. The overall allocation of the rearrangement for resolution of this overload is \$2.978 million and the

- estimated time to complete is 2 years. This project will be allocated a portion of the cost based upon the its relative impact upon the facility.
- H. The overload on the Homer City #2 transformer, problem 11, will be alleviated by the installation of a 345 kV breaker at Homer City. The total cost for the breaker installation is estimated at \$1.75 million and the estimated time to complete is 1 year. This project will be allocated a portion of the cost based upon the its relative impact upon the facility.
 - I The overload on the Homer City #2 transformer, problem 12, will be alleviated by the installation of a 345 kV breaker at Homer City. The total cost for the breaker installation is estimated at \$1.75 million and the estimated time to construct is 1 year. This project will be allocated a portion of the cost based upon the its relative impact upon the facility.
 - J. The overdutied breakers described in 13 above will either be replaced or their interrupting capability will be increased. The total cost for replacing or upgrading overdutied breakers at Homer City is not expected to exceed \$4 million. Depending on the number of breakers it is estimated it will take 1 to 2 years to complete.

Total Cost

The total cost for the network upgrades to interconnect this project to the system are estimated to be in a range between \$33.1 and \$41.8368. The range of cost is dependant upon the percentage of the upgrades described in G through J above that are allocated to this project. It will take approximately 4 years to complete all of the upgrades required. The time to construct is dependent upon obtaining facilities outages in a timely manner as required for construction.

The project may be assessed operating and maintenance costs for the facilities required for interconnection of the project. These costs will be defined in later evaluations. It can be anticipated the present value of these costs will approximate 10% of the capital cost for interconnection.

Figure #2

Erie West 345 kV

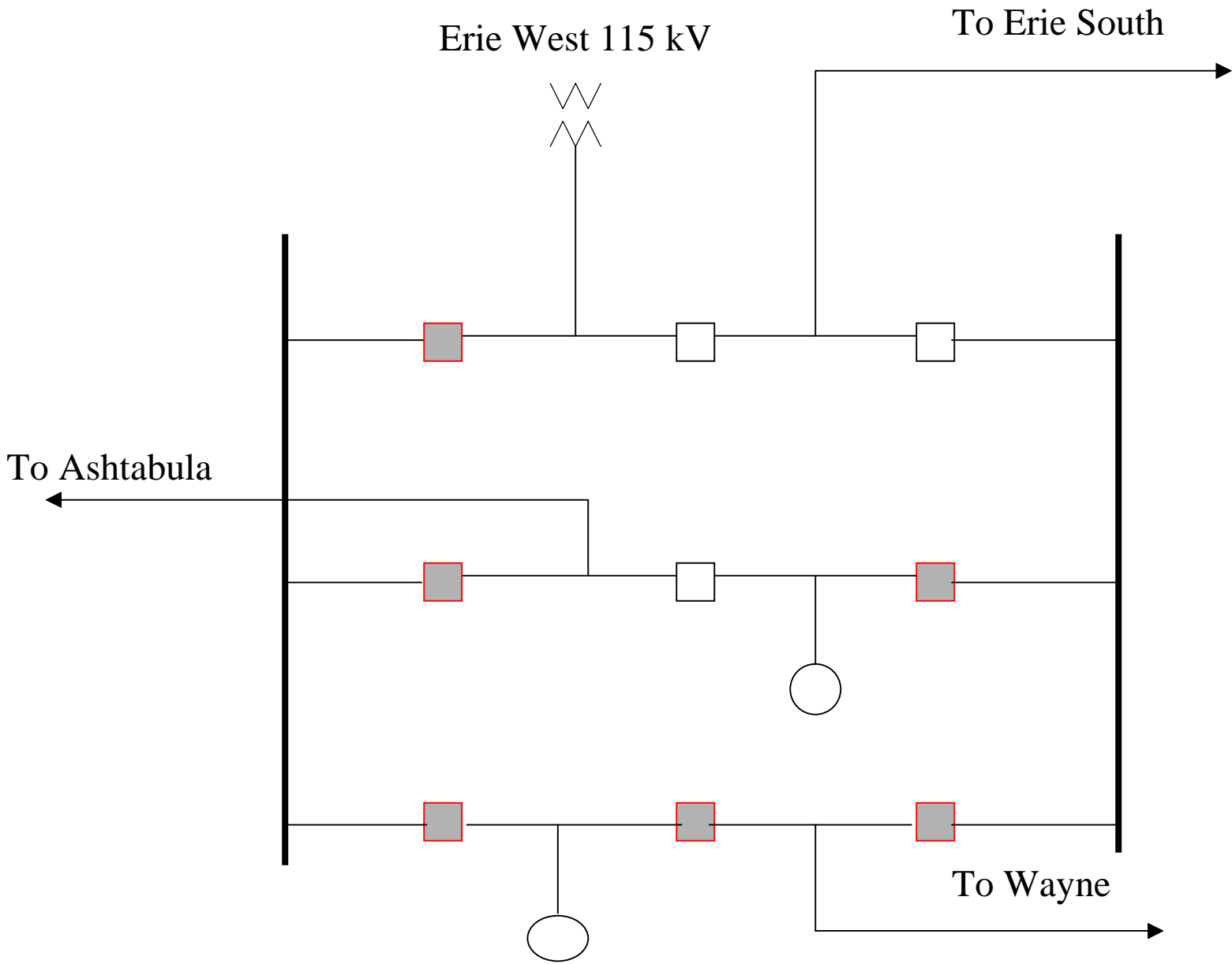

Figure #3

Homer City 500 / 345 kV Substation

