

***PJM Generator Interconnection Request  
Queue #B36  
South Akron 230 kV  
Feasibility Study Report***

**August 2000**  
DMS#123453 v2

## **South Akron 230 kV Feasibility Study**

### **General**

PP&L Global has proposed a new 100 MW generating facility consisting of two LM6000 gas fired combustion turbines, to be installed in West Earl Township, Lancaster County, Pennsylvania. The project will be connected to the South Akron 230 kV bus. The proposed service date for the project is June 2002.

The intent of the feasibility study is to determine ballpark cost and construction time estimates of system reinforcements required to facilitate the addition of the new generating plant to the PJM system. The reinforcements include the direct connection of the generator to the system and any network upgrades necessary to maintain the reliability of the PJM system.

### **Direct Connection**

To connect the generating facility to the South Akron 230 kV system, the following work is needed:

- Install a new double breaker bay in the Bay 6 position of the 230 kV switchyard, including all foundations, circuit breakers, controls and protection, deadends, air switches, CCVT, etc. as shown in Figure 1.
- Construct 500 feet of new 230 kV single circuit line with two steel poles. Direct Transfer Trip using OPGW or ADSS, as well as fiber optic terminal equipment will be needed.

The estimated lead-time for engineering through in-service is 24 – 30 months with an estimated cost of \$2,510,000.

This work is also required for the direct connection of project B35. The connection for the proposed queue position B-35 project will accommodate two additional 45 MW generators. The cost of the direct connection facilities will be allocated proportionately between projects B35 and B36. If project B-35 does not proceed, project B-36 will be responsible for the full direct connection costs identified.

Network Requirements

Figure 1  
B36 Akron 230 kV Switchyard

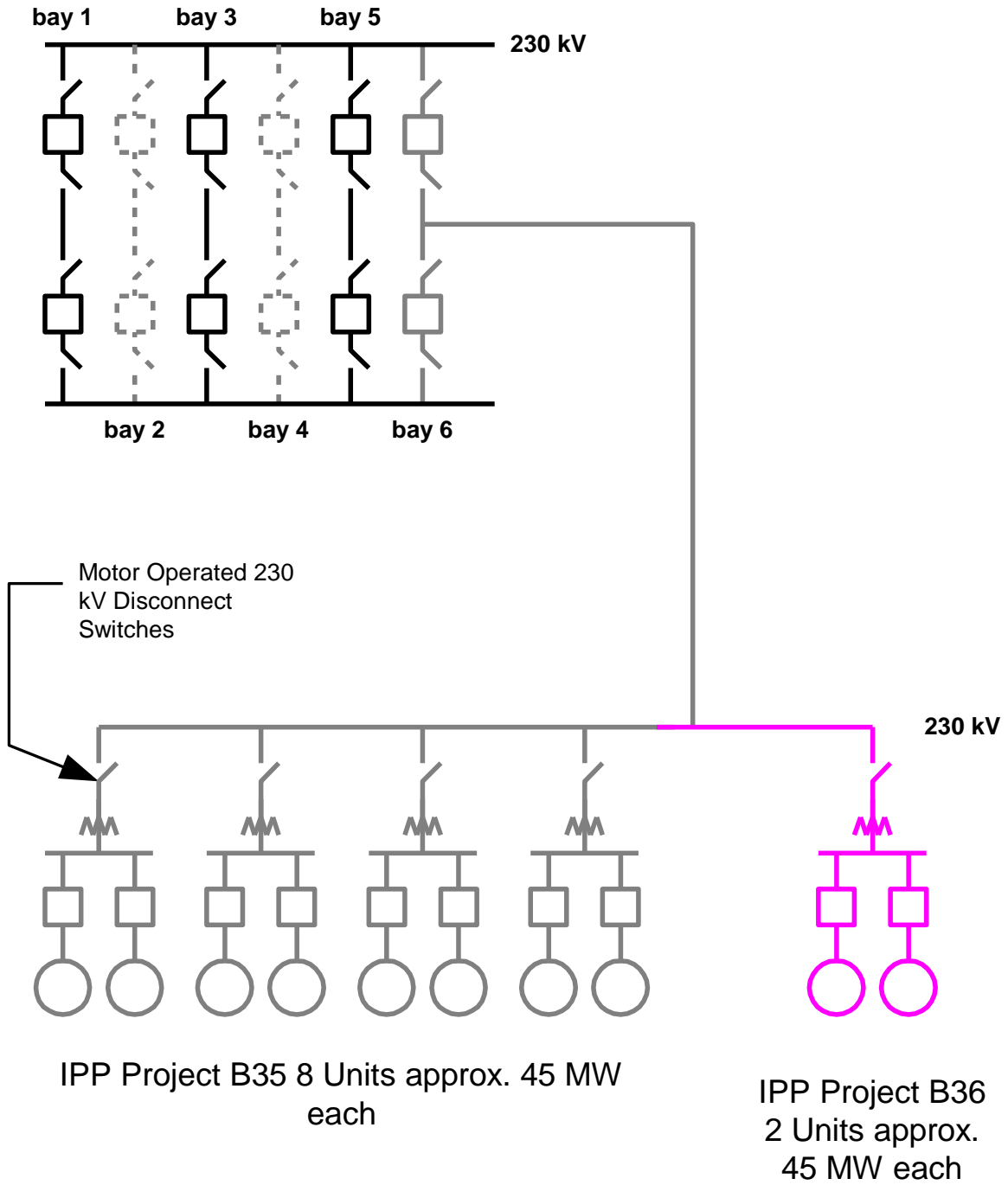

## **Network Impacts**

Potential network impacts for the injection of 100 MW into the South Akron 230 kV bus were evaluated for summer peak conditions in 2004.

A summary of the results follows:

### **Normal System**

- No identified problems.

### **Multiple Facility Contingency (MAAC Criteria IIC)**

- No identified problems.

### **Generator Deliverability**

- No identified problems.

### **Short Circuit Analysis**

- Increases the short circuit duty through two Manor (West Hempfield and Graceton) 230 kV and one South Reading (Transformer #7) 230 kV circuit breakers identified for a previously queued project.
- Increases the short circuit duty through two South Akron (South Manheim #3 and Morgantown #1) 69 kV circuit breakers identified for a previously queued project.

## **System Reinforcements**

- Replacement of two 230 kV circuit breakers at Manor is estimated to cost \$ 700,000.
- Replacement of one 230 kV circuit breaker at South Reading is estimated to cost \$ 350,000.
- Replacement of two 69 kV circuit breakers at South Akron is estimated to cost \$ 350,000.

It is estimated all five circuit breakers will be replaced in 24 – 30 months. Total network enhancement costs are estimated at \$1.4 million. This project will be responsible for a portion or possible all of the network reinforcements listed.