

Generation Interconnection

This analysis was completed to assess the reliability impact for a new generator interconnecting to the PJM system as a capacity resource.

Network Impacts -610 MW Injection into the Johnstown 230kV substation (G31)

Network Impacts

Potential network impacts for the injection of 610MW into the Johnstown 230 kV transmission substation was evaluated for summer peak conditions in 2005.

Generator Deliverability

- 1) The Glory – Dixonville East 115 kV circuit is contingency overloaded at 105% of the emergency rating (124MVA) for the outage of the Wayne – Handsome Lake 345 kV circuits. The G31 project contributes approximately 30 MW to the loading on this circuit.
- 2) The Garrett – 01Garrett 115 kV circuit is contingency overloaded at 110% of the emergency rating (106MVA) for the outage of the Homer City – Keystone 230kV circuits. The G31 project contributes approximately 50 MW to the loading on this circuit.
- 3) The Altoona – Johnstown 230 kV circuit is overloaded at 100% of the normal rating (488 MVA). The G31 project contributes approximately 100MW to the loading of this circuit.
- 4) The Altoona - Johnstown 230 kV circuit is contingency overloaded at 110% of the emergency rating (554MVA) for the outage of the Homer City – Keystone 230kV circuits. The G31 project contributes approximately 140 MW to the loading on this circuit.
- 5) The Altoona – Raystown 230 kV circuit is contingency overloaded at 100% of the emergency rating (554MVA) for the outage of the Homer City – Keystone 230kV circuits. The G31 project contributes approximately 150 MW to the loading on this circuit.
- 6) The Homer City – Keystone 230 kV circuit is contingency overloaded at 100% of the emergency rating (854MVA) for the outage of the Wayne – Erie West 345 kV circuit coupled with the outage of the Wayne 230/115 kV transformer. The G31 project contributes approximately 280 MW to the loading on this circuit.
- 7) The C. Slope – Westfall 115 kV circuit was contingency overloaded at 100% of the emergency rating (175 MVA) due to the outage of the Altoona – Johnstown 230 kV circuit coupled with the Altoona 230/46 kV transformer.
- 8) The Keystone 500/230 kV transformers are contingency overloaded at 105% of the emergency rating (488 MVA/492 MVA) due to the outage of the other Keystone 500/230 kV transformer.

Multiple Facility Contingency – Tower Line Outages (MAAC Criteria IIC)

No problems identified

Short Circuit

- Short circuit analysis was not performed due to the magnitude of reinforcements required to eliminate the identified overloads. Any required breaker replacements are not expected to materially alter the total network reinforcement cost.

New System Reinforcements

All identified overloads, described above, can be eliminated by constructing a new 230 kV circuit between Johnstown substation and a new 500kV substation, Hinckston Run, that is proposed to allow for the addition of projects D21 and D22 to the Conemaugh-Hunterstown 500kV circuit and upgrades of line traps at Altoona 230kv substation. The new line will be connected to the Hinckston Run 500kV substation through a new 500/230 kV, 650MVA transformer. See Figure #2. The reinforcement will consist of expanding the Hinkston Run 500kV substation by one breaker, adding a 500/230kV transformer and 230kV circuit breaker at Hinckston Run, building a 230kV circuit from Hinckston Run to Johnstown and expanding the Johnstown 230kV substation by one circuit breaker. If the D21 and D22 projects withdraw from the Generator Interconnection process the G31 project will be required to build a 3 breaker ring bus at Hinckston Run at an estimated cost of \$11.9 million.

The following network reinforcements are required:

1. Expand the Johnstown 230kV substation by adding one 230kV circuit breaker to create a new position for termination of the line to Hinckston Run. The estimated cost is \$1.094 million and the estimated time to completion is 2 years.
2. Construct a 230kV transmission line approximately 1.5 miles in length between Johnstown 230kV substation and Hinckston Run substation. The estimated cost is \$1.5 million and the estimated time for completion is 2.5 years.
3. Provide the structure at Hinckston Run substation for attachment of the new line. The estimated cost is \$0.16 million and the estimated time for completion is 9 months.
4. Install a 500/230kV transformer at Hinckston Run substation. The estimated cost is \$4.975 million and the estimated time for completion is 1.5 years.
5. Expand the Hinckston Run 500kV ring bus substation by one breaker to provide a position to terminate the transformer. The estimated cost is \$2.358 million and the estimated time to completion is 2 years. The project will also be responsible for an approximate allocation of \$3.2 million for the initial cost of providing the Hinckston Run 500kV substation.
6. Replace the line trap on the Altoona terminal of the Altoona-Johnstown 230kV line to increase the line rating to the conductor ratings of 499normal/617 4-hour emergency. The estimated cost is \$0.056million and the estimated time to completion is 6 months.
7. Replace the line trap on the Altoona terminal of the Altoona-Raystown 230kV line to increase the line rating to the conductor ratings of 499normal/617 4-hour emergency. The estimated cost is \$0.056million and the estimated time to completion is 6 months.

The network upgrades for this project are estimated to be \$14.407 million if the D21 and D22 projects move forward or \$20.749 million if those two projects withdraw from the queue. These estimates do not include gross-up for state taxes of approximately 30% and federal taxes (CIAC). IRS has recently ruled that for Interconnection Agreements signed after 12/24/01 gross-up for Federal Taxes is not required for generator interconnection facilities.

It will be the project developer's responsibility to acquire the right-of-way for the new 230kV transmission line. This will require easements on property owned by the developers of projects D21 and D22.

It is estimated that it will take 2 years from execution of an Interconnection Service Agreement to complete the direct connection requirements for this plant and 2.5 years to complete the network upgrades. This time estimate assumes outage of the Conemaugh-Hunterstown 500kV line, the Johnstown-Bon Air 115kV line and those outages for the reconfiguration of the Johnstown 230kV substation can be scheduled as requested.

Figure #2

**G31 Johnstown
Johnstown - Hinckston Run
230 kV Circuit**

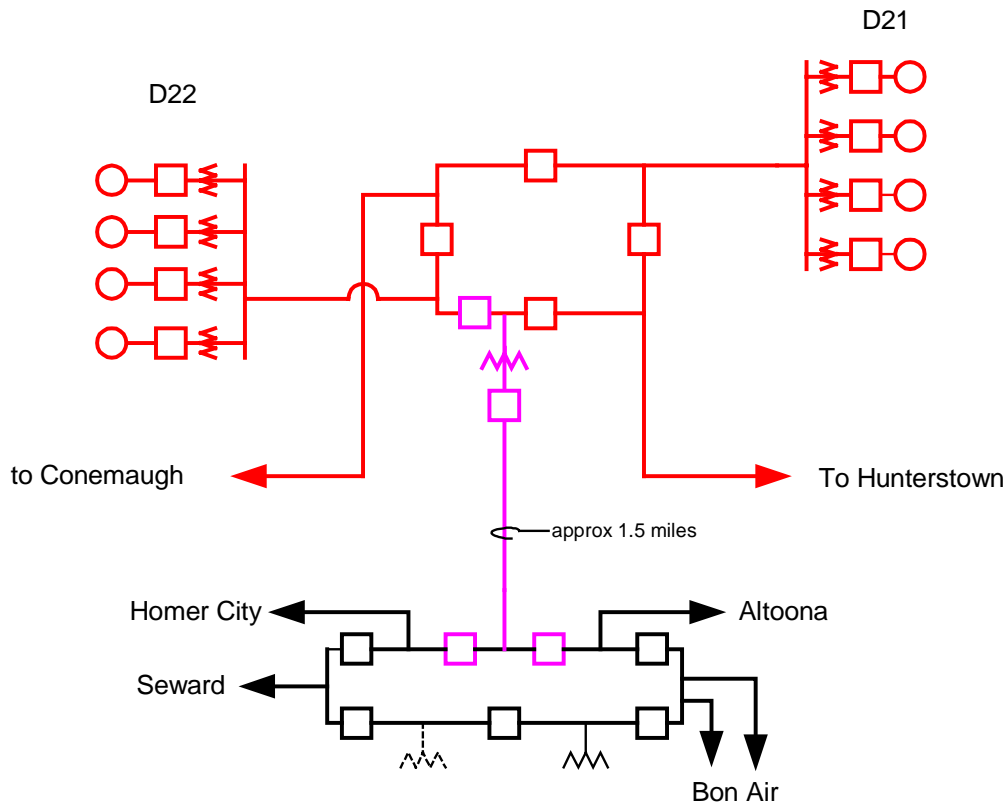

Contribution to Previously Identified System Reinforcements

The G31 project will be allocated a percentage of the costs for the following previously identified network reinforcements:

1. Project G31 contributes to a previously identified voltage drop problem at the Juniata 500 kV substation. The voltage drop will be alleviated by installing an SVC at the Juniata 500 kV substation. Estimated cost for installing a 350 MVAR SVC at Juniata determined to be necessary for previous projects is estimated to cost \$24.4 million. This includes the capacitors, approximately sized transformers, 500 kV circuit breakers, all associated controls, site prep and substation modifications. It does not include gross-up for taxes. The SVC is estimated at \$16.5 million and site expansion costs and line relocations at \$ 7.9 million.
2. The project will also be responsible for an approximate allocation of \$3.4 million for the initial cost of providing the Hinckston Run 500kV substation.

The actual cost allocation amounts for network upgrades required by more than one generation project will be defined in the impact study report.

Cost allocation percentages are not normally provided as part of the Feasibility Study analysis, however, cost allocation will be provided at the conclusion of the Queue D, E, F & G Impact Study evaluations.