

***PJM Generator Interconnection Request
Queue #K3
Wright (Mountain Top) 69 kV
Feasibility/Impact Study Report***

204975
March 2003

Wright (Mountain Top) 69 kV Feasibility/Impact Study

General

Energy Unlimited Inc. has proposed a new 39.6 MW generating facility consisting of twenty four wind turbines to be installed in Mountain Top Township, Luzerne County, Pennsylvania. The proposed service date for the project is prior to December 31, 2003. This generation project is being evaluated as an "Energy Only" resource.

The intent of the feasibility/impact study is to determine cost and construction time estimates of system reinforcements required to facilitate the addition of the new generating plant to the PJM system. The reinforcements include the direct connection of the generator to the system and any network upgrades necessary to maintain the reliability of the PJM system.

Direct Connection

The project will be connected to the Jenkins-Harwood #2 69kV line near transmission structure 52353N38084 via a line tap to a substation at the wind farm site. See Figure #1 below. Based on latest information the transmission line work for the connection is estimated to cost \$700,000. The substation work necessary at Jenkins to accommodate the project is estimated to cost \$400,000. If PPL Electric Utilities is to provide the metering equipment, the metering costs are estimated to be \$50,000. In order to support the short engineering and construction schedule requested by Energy Unlimited Inc., overtime costs are expected. The estimated additional costs due to overtime are anticipated to be approximately \$170,000. Total direct connection cost is **\$1,320,000** plus applicable taxes (if any).

Assuming custom designed steel poles are not required and standard steel poles can be ordered, the estimated time to complete the installation is 12/31/03. This assumes the Facility Study agreement is signed by 4/1/03 and that the PJM Interconnection Service Agreement is executed by 5/15/03.

Transmission Work

The above transmission cost includes siting, R/W acquisition and construction of a two span tap, designed and operated at 69kv, that runs from the Jenkins-Harwood #2 circuit to the Energy Unlimited (EUI) dead end structure. Replacement of the existing angle pole structure at grid 52353N38084 with a two-pole structure is included. Since the tap will be designed according to 69kv transmission standards at EUI's request, EUI will be responsible for any and all future costs to convert this tap to 138kv operation when and if this occurs.

Substation Work

The work at Jenkins substation includes installation of the RFL type 9745 DTT equipment, installation of synchrocheck facilities, control design modifications and installation of telephone circuit protection equipment. EUI will be responsible for procurement of a protective relay grade telephone circuit for the DTT facilities from the Telephone Company. DTT telephone circuit monthly lease fees will be the responsibility of EUI.

The facility will use induction machines to produce electrical power. Depending upon the design of the collector system for the generation at the EUI facility, self-excitation of the induction machines may be possible. If self-excitation is determined to be a concern, protection requirements as well as the circuit breakers used by EUI to isolate their system from the PPL Transmission system may change significantly during the PJM Facility Study (engineering detailed design). These changes may include the stipulation that EUI be required to purchase CBs rated twice the nominal phase to phase voltage for the intertie 69kV CB and the low side 34.5kV CB.

In order to eliminate significant voltage deviation, the generator will need to operate at approximately a 97.0% leading power factor (The IPP may be required to install automatic controlled shunt reactors to reduce the voltage change and achieve the above leading mode of operation). Load Flow Studies indicate that at maximum 39.6 mw output, EUI will be required to absorb approximately 10 mvar from the system as measured at the 69kV intertie connection point. The intertie transformer will absorb some of the mvar. EUI must ensure that they have the capability to absorb the remainder and hold a 97.0% power factor over the entire mw output range.

Figure #1

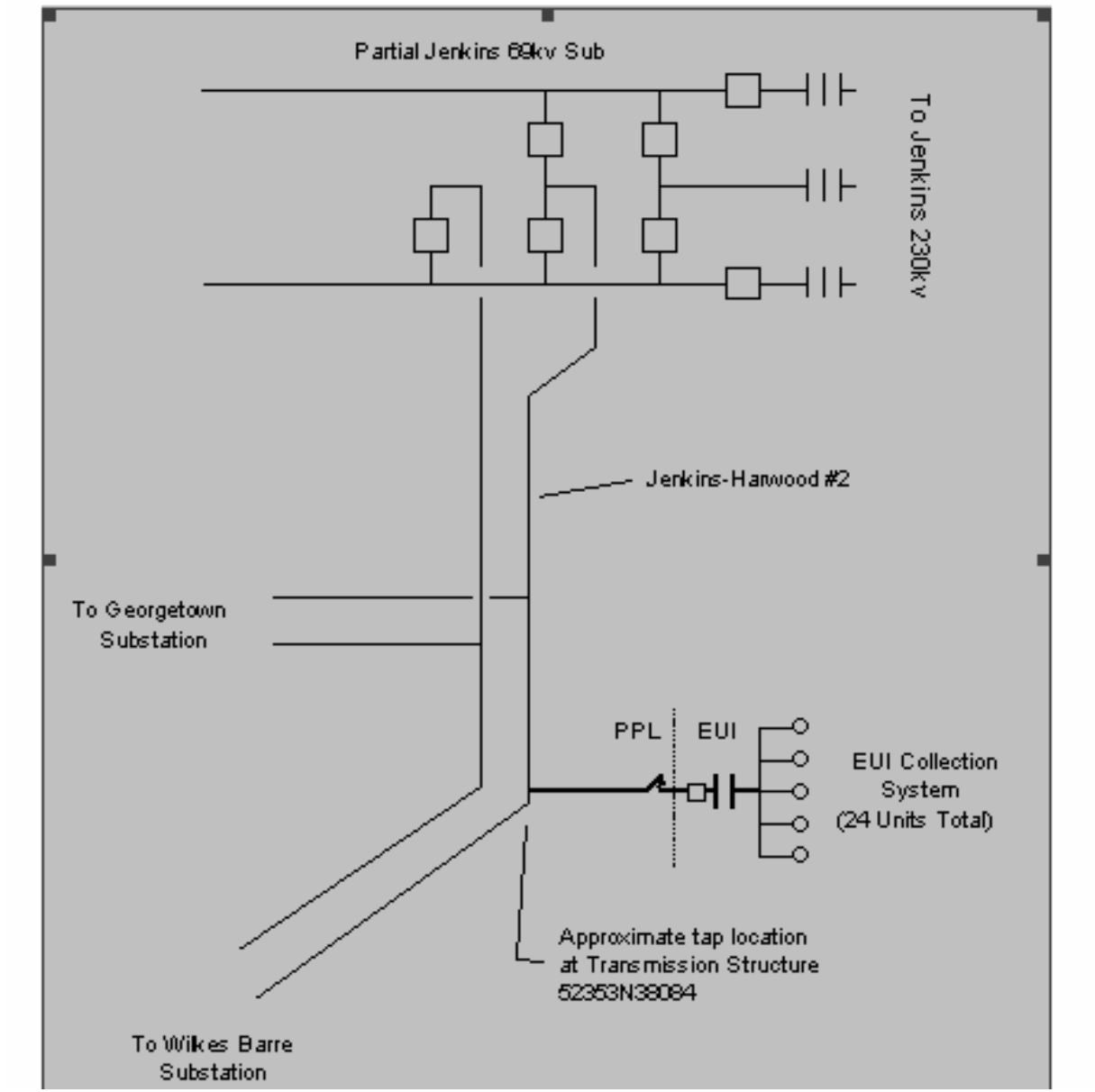

Network Impacts

Potential network impacts for the injection of 39.6 MW into the Jenkins-Harwood #2 69 kV circuit are listed below. The project was evaluated as an energy only facility.

Normal System

- No identified problems.

Multiple Facility Contingency (MAAC Criteria IIC)

- No identified problems

Generator Deliverability

- No identified problems for an energy only unit. See E08 Feasibility report for examples of contingency conditions which may cause energy only unit curtailment.

Short Circuit Analysis

- No identified problems

System Reinforcements

- None identified for an energy only unit.

Energy only generating facilities may be curtailed by PJM based upon transmission system conditions. Since the proposed facility will be unmanned, when requested by PJM, PPL Electric Utilities operations center will initiate a SCADA control signal via telephone to disconnect the generation.