

***PJM Generator Interconnection Request
Queue #058
Tenn. Eastman 138kV
Feasibility/Impact Study***

**362427
March 2006**

O58 Tenn. Eastman Feasibility/Impact Study

General

Tennessee Eastman proposes to make available 75 MW of their generation in Kingsport Tennessee (PJM Project #IPP 058) into the PJM market. Tennessee Eastman is connected to American Electric Power (AEP) at Holston Station (Figure #1). The customer's generating facilities are connected behind the AEP's revenue meters. The in-service date for this proposed transaction is the second quarter of 2006.

The intent of the feasibility / impact study is to determine system reinforcements and associated costs and construction time estimates required to facilitate the addition of the new generating plant to the transmission system. The reinforcements include the direct connection of the generator to the system and any network upgrades necessary to maintain the reliability of the transmission system.

Direct Connection

The Tennessee Eastman generation facilities are connected behind the AEP metering point at the Holston Station. In order to make this customer generation available in the PJM market, additional metering facilities are required to properly monitor customer generation and load. This will require installing Remote Terminal Units (RTU's) and upgrading the existing meters at the Holston Station.

The construction scope includes:

Direct Connection Costs (in 2006 dollars)

- Holston Station: install two RTUs and upgrade the existing metering
Estimated Cost* \$ 456,800
- Tennessee Eastman: install metering, to include MW, MVAR, MWH and MVARH, on seven generators (#16, 17, 18, 19, 20, 22 and 26) that have been designated by Tennessee Eastman inside their plant that will be participating in the PJM market.
Estimated Cost* \$ 440,600

Total Estimated Direct Interconnection Cost* \$ 897,400

* The estimates are preliminary in nature, as they were determined without detailed engineering and design studies. Final estimates will require on-site review and coordination with Tennessee Eastman to determine final construction requirements. It will take approximately nine months after obtaining the authorization to construct the facilities as outlined above.

Figure #1

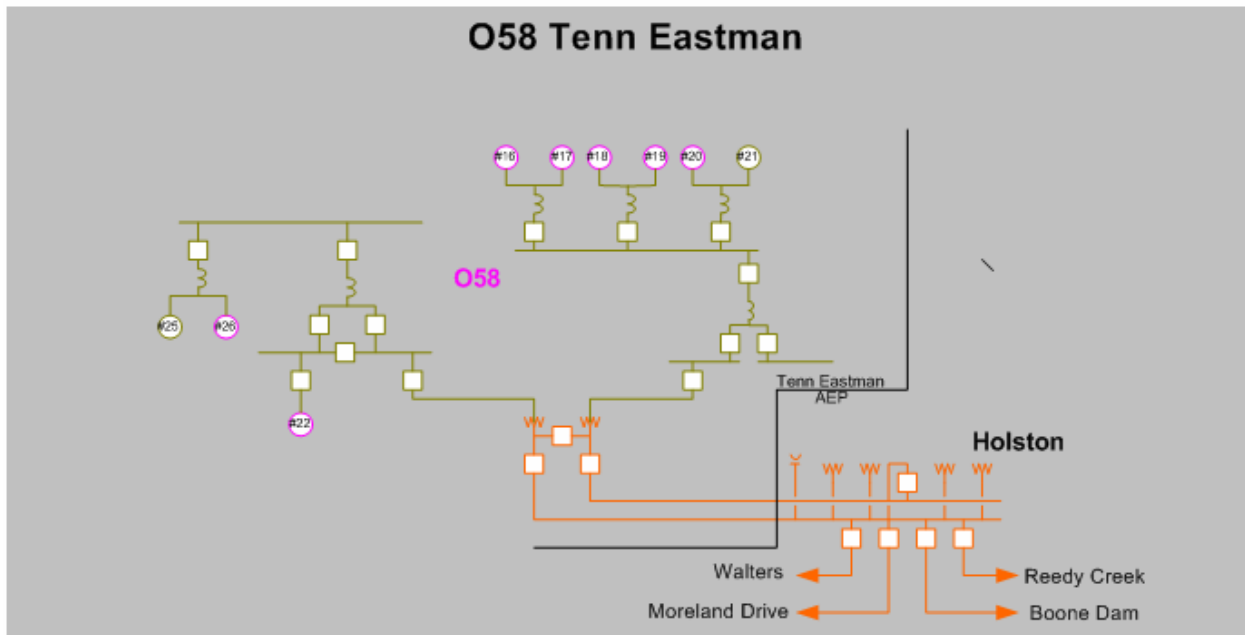

Network Impacts

The #O58 project was studied as an injection of 75 MW into the Tennessee Eastman #1 substation that connects to the AEP Holston station. Project #O58 was evaluated for compliance with reliability criteria for summer peak conditions. Potential network impacts were as follows:

Generator Deliverability

No problems identified

Multiple Facility Contingency

No problems identified

Short Circuit

Not required, since there are no changes to the generating unit electrical characteristics.

Stability Analysis

Not required since there are no changes to the generating unit electrical characteristics.

New System Reinforcements

None

Contribution to Previously Identified System Reinforcements

None

#058 – Tennessee Eastman 138kV
Generation Interconnection

This analysis was completed to assess the reliability impact for an existing generator moving from behind the meter and interconnecting to the PJM system as a capacity resource.

Network Impacts

The #058 project was studied as an injection of 75 MW into the Tennessee Eastman #1 substation that connects to the AEP Holston station. Project #058 was evaluated for compliance with reliability criteria for summer peak conditions. Potential network impacts were as follows:

Generator Deliverability

No problems identified

Multiple Facility Contingency

No problems identified

Short Circuit

Not required, since there are no changes to the generating unit electrical characteristics.

Stability Analysis

Not required since there are no changes to the generating unit electrical characteristics.

New System Reinforcements

None

Contribution to Previously Identified System Reinforcements

None