

**PJM Generator Interconnection
Queue #P40
Crescent Ridge 138kV
20 MW (4 MW capacity)
Impact Study Report**

October 24, 2008

DOCS#: 502527

Preface

The intent of this System Impact Study is to determine a plan, with cost and construction time estimates, to connect the subject generation to the PJM network at a location specified by the Interconnection Customer. The Interconnection Customer may request the interconnection of generation as a capacity resource or as an energy-only resource. As a requirement for interconnection, the Interconnection Customer may be responsible for the cost of constructing: (1) Direct Connections, which are new facilities and/or facilities upgrades needed to connect the generator to the PJM network, and (2) Network Upgrades, which are facility additions, or upgrades to existing facilities, that are needed to maintain the reliability of the PJM system.

In some instances a generator interconnection may not be responsible for 100% of the identified network upgrade cost because other transmission network uses, e.g. another generation interconnection, may also contribute to the need for the same network reinforcement.

After the System Impact Study Agreement is executed and prior to execution of the Interconnection Service Agreement, an Interconnection Customer may modify its project to reduce the electrical output (MW) (in the case of a Generation Interconnection Request) of the proposed project by up to the larger of 20 percent of the capability considered in the System Impact Study or 50 MW.

The System Impact Study estimates do not include the feasibility, cost, or time required to obtain property rights and permits for construction of the required facilities. The project developer is responsible for the right of way, real estate, and construction permit issues. For properties currently owned by Transmission Owners, the costs may be included in the study.

General

Eurus Energy North America has proposed the construction and interconnection of 20 MW of wind generation (4 MW of capacity per current PJM rules) to the ComEd transmission system, and will be located near the town of Tiskilwa in Bureau County, Illinois. This 20 MW of wind generation is identified as Phase III of the Crescent Ridge Wind Farm. PJM has assigned this project queue #P40 Crescent Ridge 138kV. Queue #P40 has been evaluated in this Impact Study as an “Energy Only” resource for its full output capability of 20 MW and as a “Capacity” resource for 20% (4 MW) of its capability. The proposed project in service date is 06/01/2009, but this is being reviewed due to the availability of long lead time items, as well as resource scheduling issues..

Attachment Facilities

It is proposed that the P40 Crescent Ridge 138kV Phase III project be interconnected to the transmission system at the existing ComEd TSS 981 Crescent Ridge 138kV substation as depicted in Figure #1. **This figure had been prepared with the information available at the time the studies were conducted. Subsequent data submittal has been received by the Transmission Provider resulting in a change of the equipment configuration on the Interconnection Customer side of the Point of Interconnection, but does not materially change the results of this study. Any changes to the results of this study will be noted in the subsequent Facilities Study.**

This existing interconnection substation is a four-breaker H-bus configuration with terminations for L7413 (Crescent Ridge – Kewanee line), L7713 (Crescent Ridge – Mazon line), a connection to another windfarm (Providence Heights Wind Farm, PJM Queue O35) and L98101 which is the high-voltage output from the existing Crescent Ridge Wind Farm into the Crescent Ridge substation.

As per the attached proposed interconnection diagram (Figure #1), the developer, Eurus Energy North America, is responsible for constructing all of the facilities on its side of the point of interconnection. This includes the installation of a new, properly sized, 34.5 kV to 138 kV step-up transformer (identified as TR 77), an additional 34.5 kV circuit breaker, and additional 34.5 kV collection buses, coming from the new wind generators. These new facilities will then be connected to the output of the existing Crescent Ridge Wind Farm (L98101), which is already interconnected to the Crescent Ridge substation TSS 981. See Figure #1. Eurus Energy North America will also be responsible for any remote relay and control work at both the Kewanee and Mazon substations that is required due to the interconnection of the wind facility, along with any system upgrades identified, attributable to this project, to ensure system reliability.

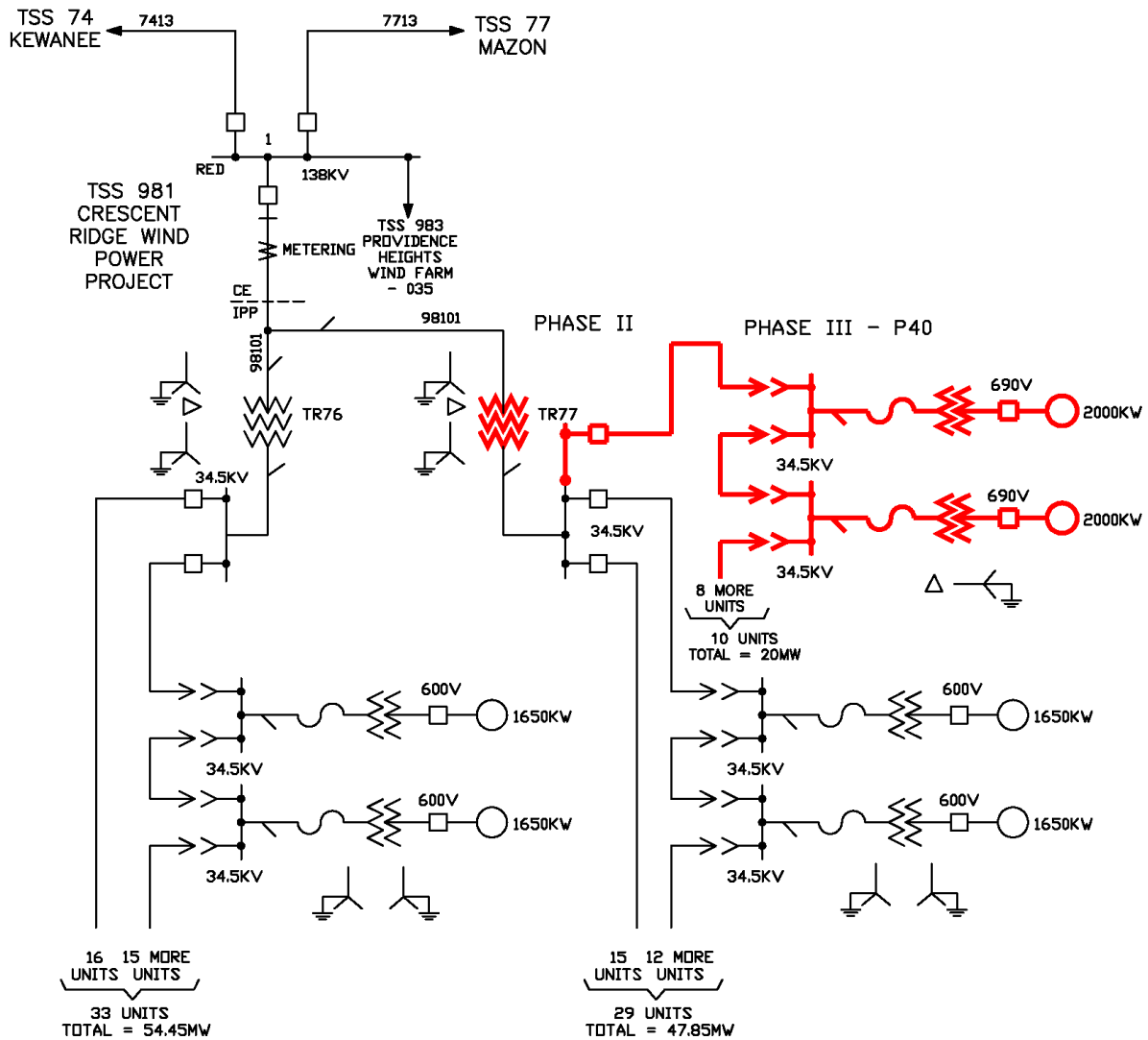

Figure #1: Proposed Point of Interconnection

Cost Responsibility for System Upgrades

The Interconnection Customer is responsible for the following cost components that are identified as part of the Impact Study together with other cost components that will be identified as a result of the Facilities Study.

a) Cost of Direct Connection Network Upgrades

The total preliminary estimate for Direct Connection cost is \$50,000 for potential modifications at TSS 983 Crescent Ridge including, but not limited to, relay setting changes and revenue metering modifications.

Cost estimate notes:

- 1) This Estimate is an "Order of Magnitude" cost estimate only, since it is not supported by engineering analysis and is based only on a one-line electrical diagram of the project. Accordingly, this estimate is not a guaranty of the maximum amount payable by Eurus Energy hereunder and the actual costs of ComEd's work may differ significantly from this estimate. Customer will be responsible for paying all actual costs of ComEd's work.
- 2) The combined Crescent Ridge Wind Farm II and Crescent Ridge Wind Farm III will consist of 29-2.3MW wind turbines for a total of 66.7MW. Figure 1 does not reflect this configuration, but that which had been previously submitted by the developer. Any impacts due to this change of configuration will be addressed in the Facilities Study. The wind farm is interconnected with the addition of a 138kV-34kV transformer and a 34kV bus at the customer's collector substation. TSS981 is an existing substation.
- 3) Customer Interconnection: Customer responsible for all engineering, procurement, testing, and construction of all equipment on Customer side of the Point of Interconnection. Coordination of various engineering review, witness testing, metering and telemetry from customer side of the Point of Interconnection may be ComEd responsibility but cost is responsibility of customer.

b) Cost of Non-Direct Connection Network Upgrades

This includes the cost of any remote relay and control work that is required at the remote ends of the lines due to the interconnection of the wind facility and communication equipment, along with any system upgrades identified, attributable to this project, to ensure system reliability.

Also included in the category of Non-Direct Connection Network Upgrades are the upgrades required to eliminate reliability criteria violations, which are listed in subsequent sections of this report. These necessary upgrades may have cost allocations to other queue positions, and the portion that will be the responsibility of this Interconnection Customer as indicated below.

No Non-Direct Connection Network Upgrades have been allocated to this project.

c) Cost of Revenue Metering

This includes the cost of revenue quality metering at the Point of Interconnection. This metering shall be capable to provide bi-directional revenue metering (KWH, KVARH) and real time data (KW, KVAR, Voltage) for the generating resource both to PJM (See PJM Manuals M-01 and M-14D, and PJM Tariff Section 58.1 through 58.5) and ComEd (See ComEd Applicable Technical Requirements and Standards available on the PJM website ("TO Standards") – "Exelon Energy Delivery Interconnection Guidelines (Generators Greater than 20 MW)").

Interconnection Customer shall have the right to install, own, operate, test and maintain the necessary Metering Equipment. If the Interconnection Customer does not exercise this option, the Interconnected Transmission Owner shall have the option to install, own, operate, test and maintain all necessary Metering Equipment at Interconnection Customer's expense. For the purpose of this report, it is assumed that the Metering Equipment will be installed by the

Interconnection Customer on the Interconnection Customer's side of the Point of Interconnection.

Direct Connection Schedule:

The Schedule will be determined as part of the Facilities Study/ISA negotiations. At this point, it is believed that ComEd will be able to accommodate a **Fall 2009 service date**.

Network Impacts

The Queue Project #P40 was studied as a 20 MW (Capacity of 4 MW) injection at Crescent Ridge TSS 981 138kV substation in the ComEd area. Project #P40 was evaluated for compliance with reliability criteria for summer peak conditions in 2011. The load flow portion of this study assumes the wind farm has the capability to maintain unity power factor at the 34.5kV collector bus. Potential network impacts were as follows:

Generator Deliverability

(Single or N-1 contingencies for the Capacity portion only of the interconnection)

No problems were identified.

Multiple Facility Contingency

(Double Circuit Tower Line, Line with Failed Breaker and Bus Fault contingencies for the full energy output)

No problems were identified.

Short Circuit

(Summary of impacted circuit breaker)

No problems were identified.

Contribution to Previously Identified Overloads

(This project contributes to the following contingency overloads, i.e. "Network Impacts", identified for earlier generation or transmission interconnection projects in the PJM Queue)

1. This project contributes 6.7 MW to the previously overloaded ComEd-owned Kewanee 138kV Main Bus to AmerenIP-owned Kewanee 138kV circuit breaker #105 and series equipment which loads from 120.0% to 122.1% of its applicable load dump rating (323MVA) for the Kewanee–Hennepin–Streator and Crescent Ridge–Oglesby–Mazon 138kV tower line outage (6101 & 7713).

Steady-State Voltage Requirements

(Summary of VAR requirements bases on upon the results of the steady-state voltage studies)

None identified.

Stability and Reactive Power Requirement for Low Voltage Ride Through

(Summary of VAR based upon the results of the dynamic studies)

To be determined in the Facility Study.

New System Reinforcements

(Upgrades required to mitigate reliability criteria violations, i.e. Network Impacts, initially caused by the addition of this project generation)

None

Contribution to Previously Identified System Reinforcements

(Overloads initially caused by prior Queue positions with additional contribution to overloading by this project. This project may have a % allocation cost responsibility which will be calculated and reported for the Impact Study)

1. The overload of the ComEd-owned Kewanee 138kV Main Bus to the AmerenIP-owned Kewanee 138kV circuit breaker #105 and series equipment can be relieved on the ComEd portion by upgrading the station conductor between the ComEd-owned Main Bus and the demarcation point with AmerenIP. There will likely be additional upgrades required in the AmerenIP system to relieve this overload. These will need to be determined through joint studies between PJM and MISO. (#P11, #P37, #P39)

(N0849)

PRJ ID	MW Contribution	% Of \$ 15K	Cost \$K
P11	10.69	15.2%	2.285
P37	36.4	51.9%	7.779
P39	16.4	23.4%	3.505
P40	6.7	9.5%	1.432

Potential Issues

The impact study results for the earlier queue project #P11 indicate a voltage collapse condition for a fault on 138 kV line 15508 with a failed breaker at Nelson TSS 155 for the dispatch of the PJM generation deliverability test for the 2011 base case. This voltage collapse condition was mitigated by installing a 138 kV circuit breaker in series (back-to-back) with the existing line 15508 circuit breaker. This solution eliminates this critical contingency. If the #P11 project drops out of the PJM queue, the voltage collapse issue will need to be re-evaluated and #P40 may ultimately be responsible for the solution.

Impacts on the MISO member transmission systems are not included in this analysis, but they will be included in the Facility Study, which may indicate upgrades needed in the MISO system not identified in this Impact Study.

Potential Congestion Issues

(For wind projects) There are several wind generation plants proposed in the general area of the #P40 project, each with only 20% of their peak output level considered as a Capacity Resource, and the remaining 80% as an energy only resource. If all of the wind generation plants are at their maximum output level simultaneously, a significant number of the transmission facilities, and many underlying system facilities are likely to be overloaded, restricting operation to a lower output level.

PJM and the Transmission owner(s) studied the delivery of the energy portion of this interconnection request. The following analysis has been performed to inform the Interconnection Customer of potential congestion issues (operational restrictions) that may occur and affect the #P40 project's ability to operate at full output for certain system conditions. The upgrades listed below are not required reliability upgrades for the Queue #P40 interconnection. Please note that the number of facilities identified below as requiring upgrades is (may be) quite extensive with a number of these facilities requiring reconductoring/rebuilding of transmission lines. Some of the reconductoring/rebuilding projects can be done in a short time frame while others are quite extensive and will require a long time to complete. In general, the time necessary to design and rebuild an extensive facility upgrade will take approximately 2-3 years to complete. If the #P40 Interconnection Customer wants to pursue construction of any of these upgrades, a separate Transmission Interconnection request must be submitted and the upgrades must be performed as merchant transmission projects. These are not required reliability upgrades.

As a result of the aggregate energy resources in the area, the following potential congestion was identified:

1. The ComEd-owned Crescent Ridge to Oglesby Tap 138kV line 7713 loads from 107.3% to 111.6% of its emergency rating (174MVA) for the outage of ComEd-owned Kewanee 138kV Main Bus to AmerenIP-owned Kewanee 138kV circuit breaker #105. This project contributes approximately 7.5MW to the overload. Previous projects P37 and P39 contribute to the loading by 13.0MW(7.5%) and 6.8MW (3.9%) respectively.