

***PJM Generator Interconnection
S01 Derwood 1.0 MW
Feasibility / Impact Study***

February 2008
Docs # 438740

General

Queue S01 is a Northeast Maryland Waste Disposal Authority request to interconnect a 1.0 MW Capacity Resource, consisting of a single gas-fired generator, to Pepco's Derwood 13.8kV substation feeder 15060 at Gude Landfill, located at 600 Gude Drive, Rockville, MD. Queue S01 is scheduled to begin commercial operation in the 3rd Quarter of 2008.

Direct Connection

Queue S01 can connect to Pepco's Derwood 13.8kV substation feeder 15060 as shown on the one-line circuit diagram shown below.

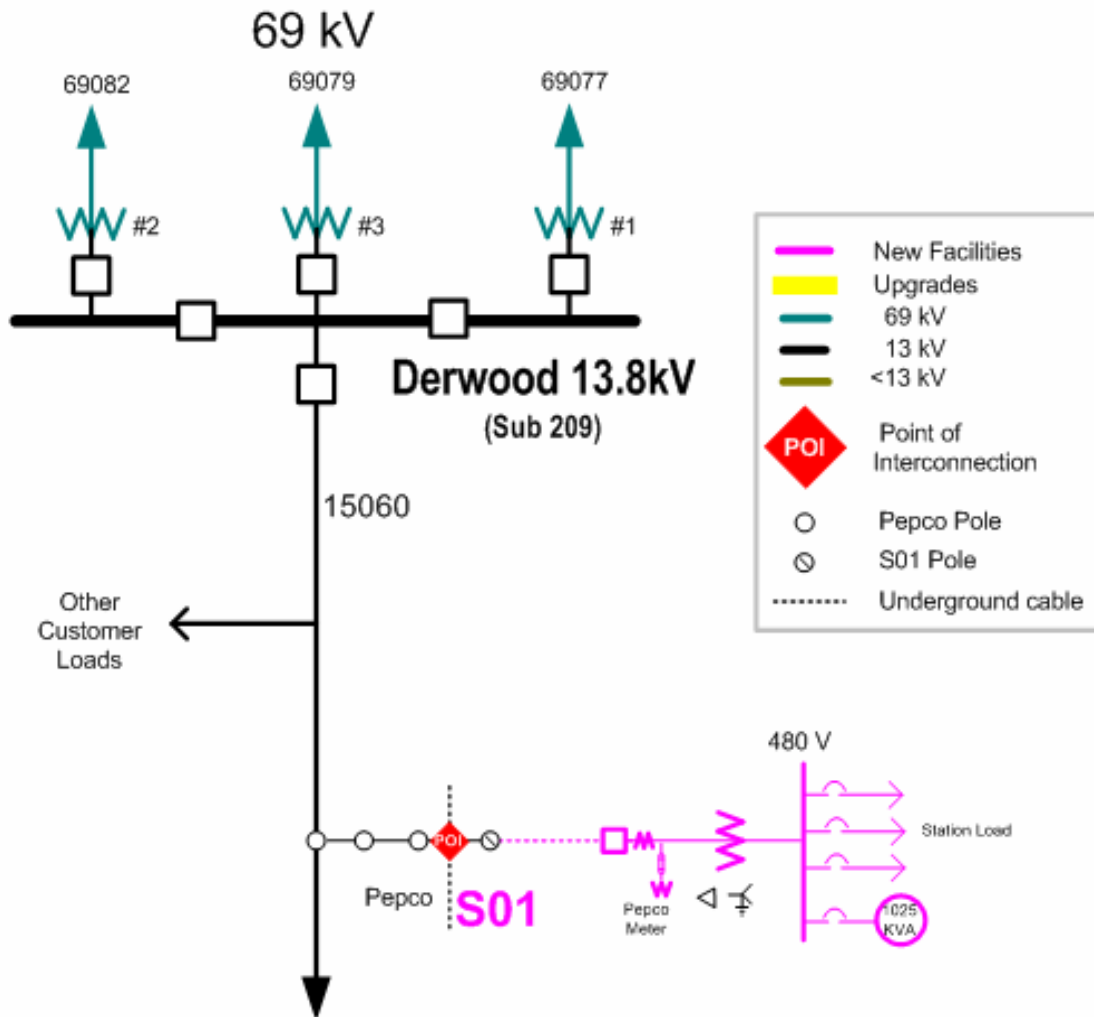

Direct Connection Scope of Work:

The Interconnection Customer (IC) will design and construct all facilities on the Queue S01 Customer's side of the POI (Point of Interconnection). Pepco will install, own and maintain the UG cable from the IC riser pole (on IC property) up to the incoming breaker cubicle terminations.

1. Pepco will provide a 13.8 kV supply to the IC. The existing recloser will be removed.
2. The IC shall install 15kV Metal-Clad switchgear for the incoming line protection.
 - a. The IC shall follow Pepco's "Guide Specification for Metal-Clad switchgear for Customer Substation 15kV, 3 Phase, 60 Hertz" SEGS051 Rev. 5 for a new high voltage service. Switchgear with ratings of 750 MVA and 31.5 kA is required. The IC shall submit the specified document for review, as noted in Section 15 of SEGS051, to Mr Will Ollison, the Pepco point of contact, at 202-388-2561, waollison@pepco.com.
 - b. The switchgear shall include an incoming circuit breaker. This breaker will act as the inter-tie breaker. The customer must provide Pepco open control of the inter-tie breaker for transfer trips. This breaker cannot be used for synchronizing with the Pepco system. Additional details on the intertie breaker SEL351 relay and its function shall be provided. If the IC already has relay setting files for this breaker, they should be submitted to Pepco.
 - c. The customer must install metering in the metal-clad switchgear as required by Pepco's "Guide Specification for Metal-Clad switchgear for Customer Substation 15kV, 3 Phase, 60 Hertz" SEGS051 Rev. 5. Pepco will provide the 15 kV current transformer, voltage transformers and fuses for the IC to mount in the switchgear at a cost of approximately **\$5,000**

Pepco will provide and program the bi-directional Meter at an estimated cost of approximately **\$2,500**.
 - d. Pepco will require transfer trip equipment between the Pepco normal supply Feeder 15060 breaker and the customer's inter-tie breaker. When the Pepco supply feeders are reconfigured to a feeder other than Feeder 15060, Pepco Operations Center will notify the customer and request that the intertie breaker be opened by the IC. If the IC has not responded to this request within a reasonable time period then the intertie breaker will be tripped by Pepco supervisory control until the normal supply feeder is returned to service. It is difficult to estimate the frequency of such requests, but it will be an operational constraint for Pepco as well.
3. The Interconnection Customer shall supply a transformer that will be used as an isolation transformer. The transformer shall have a BIL level of 95 kV. We recommend the isolation transformer be connected in a Delta-Wye configuration according to Pepco's "Engineering Requirements and Performance Standards for Interconnection Customers on the Potomac Electric Power Company System", Revision I, Dated 1-31-2007. A

Delta-Wye configuration is desirable between the utility and customer systems, in order to block zero sequence current flow through the transformer. A Delta-Wye configuration also does not contribute to overvoltages on unfaulted phases in the event a single-phase to ground fault occurs on the Pepco side of the transformer.

4. “Islanding” protection requirements: A transfer trip scheme for feeder 15060 is required to provide “Islanding” protection. This protection is required for the event where feeder breaker 15060 at Derwood opens and leaves Queue SO1 generation islanded as the only source of generation connected to Pepco retail customer load. “Islanding” protection involves the installation of a dedicated 4-wire communications circuit between Queue SO1 facility and Pepco’s Derwood Substation. Audio Tone equipment must be installed at both the customer facility and the utility’s Derwood Substation. The leased dedicated communications circuit shall be provided between the customer’s facility and Pepco’s Control Center. Pepco will be responsible for providing communications from its Control Center and its Derwood Substation. The Interconnection Customer will be responsible for providing suitable DC power and 19” Rack Space in close proximity to the inter-tie breaker as well as clearly defined termination points where Pepco can terminate a “dry” contact from the Audio Tone equipment for the purposes of tripping the inter-tie breaker in the event feeder 15060 trips or is otherwise opened by Pepco.

Pepco will be responsible for designing, procuring, installing and testing the Audio Tone equipment at both the customer’s facility and at its Derwood substation. The estimated cost for this work is approximately **\$80,000**.

The Interconnection Customer is obligated to provide a communication path (telephone line, etc.) to support the “Anti-Islanding” Protection (remote “Direct Transfer Trip” tripping by Pepco). In order to secure the needed telephone line the customer will be required to provide specific information to the local telephone company. All coordination and reoccurring costs associated with these lines will be the full responsibility of the customer and are a condition of interconnection.

When ordering telephone line services the following information must be supplied to the telecommunication service provider:

- a. Type 3002, 4-Wire voice grade, Class “A”, PTP circuit with MDRs, Basic Conditioning and Passive DST
- b. All necessary information requested by the local telephone company necessary to calculate isolation and surge protection equipment. *(It is not anticipated that PHI will need isolation and surge protection equipment at their Control Center since that facility is served by optical services. In the event services can not be provided directly to the utility’s Control Center and the local telephone company requires MDR equipment at other Pepco Facilities, all initial and reoccurring costs for that equipment will be the full responsibility of the owner. Cost of this equipment is not included in any of the estimates within this document.)*
- c. SO1 address and Pepco Control Center address (to be provided by Pepco)
- d. Specific location where each circuit is to be terminated at the facility.

In the event technical assistance is needed to order these services, the Pepco’s Telecommunications Engineering Department will assist.

5. Metering and telemetering Requirements:

For PJM:

The Interconnection Customer will be required to install the facilities necessary to provide revenue metering (KWH, KVARH) and real time data (KW, KVAR) for the Interconnection Customer's generating resource. See PJM Manuals M-01 and M-14, and the PJM Tariff.

Metering for PJM revenue and real time metering of the generator will be at the point of Interconnection to Pepco's System. This metered value is the net of generator output and generator ancillary load which is acceptable for this size unit.

The Interconnection Customer will use the Arcom director-based internet option as described in Attachment H, "Small Generator (10 MW and Below) Technical Requirements and Standards", to PJM Manual 14B. The SCADA requirement for PJM will be coordinated with Kevin Komara of PJM.

For Pepco:

Revenue Metering Requirements – See item 2c on page 3.

SCADA Requirements: The Interconnection Customer will use the Arcom director-based internet option as described in Attachment H, "Small Generator (10 MW and Below) Technical Requirements and Standards", to PJM Manual 14B.

The Interconnection Customer must provide the following status data:

- Open / Close status for Interconnection Customer inter-tie circuit breaker
- Real time KW
- Real time amperes
- Single phase voltage
- Trip control of the Interconnection Customer inter-tie breaker(s)
- Three phase amperes for the Interconnection Customer inter-tie circuit breaker.
- KWH from bi-directional revenue meter

6. The customer must submit a switching sequence of operation as well as additional documentation for Pepco's review

Network Impacts

The Queue S01 project was studied as a 1.0 MW Capacity injection into the Derwood 13.8 kV bus. The project was evaluated for compliance with transmission system reliability criteria for summer peak conditions in 2012. Potential network impacts were as follows:

Local Transmission System Impacts (Normal system conditions with all facilities in service)

No Problems were identified

Generator Deliverability

(Single or N-1 contingencies for the Capacity portion only of the interconnection)

No Problems were identified.

Multiple Facility Contingency

(Double Circuit Tower Line contingencies only for the full energy output. Stuck breaker and bus fault contingencies will be performed for the Impact Study)

No Problems were identified.

Contribution to Previously Identified Overloads

(This project contributes to the following contingency overloads, i.e. "Network Impacts", identified for earlier generation or transmission interconnection projects in the PJM Queue)

No problems were identified

Short Circuit Analysis

No problems were identified. Also see Attachment #1.

Stability Analysis

Not required for generating stations less than 30 MW.

New System Reinforcements

(Upgrades required to mitigate reliability criteria violations, i.e. "Network Impacts", initially caused by the addition of this project generation)

None required.

Contribution to Previously Identified System Reinforcements

(Overloads initially caused by prior Queue positions with additional contribution to overloading by this project. This project may have a % allocation cost responsibility which will be calculated and reported for the Impact Study)

None required.

Attachment 1

Short Circuit Analysis

PEPCO Short Circuit Study Report

Description:

The fault study was performed by modeling an Aspen Oneliner File that depicts the proposed configuration of the Gude Landfill generating station. The system modeled consisted of one (1) 1.0 MVA 480 V generator connected to a step-up transformer Wye–Grounded – Wye–Grounded (13,800/480 V). The high side (13.8 kV) of the transformer was then connected to 13.8 kV bus section No. 1 at Pepco’s Derwood Substation; No. 209 through 13.8kV Feeder 15060. The three (3) normally closed (N.C) 13.8kV buses at the Derwood substation are each supplied by a 69/13.8kV 33.6MVA transformer and are part of the Pepco Base Case Aspen Oneliner file that depicts the entire transmission and distribution system.

Assumption:

Generator characteristics used in the analysis were as provided by the developer.

Modeling Tool:

Two software packages were used to model this project:

1. The first tool used to model this project was Aspen Oneliner version 10.9. This is a PC based short-circuit and relay coordination program. The short circuit program simulates all types of classical faults, such as, bus, line-end, line-out, intermediate and simultaneous faults.
2. The second tool used to evaluate this project was Aspen Breaker Rating Module version 9.8. The Breaker Rating Module simulates faults with appropriate branch outages to find the maximum short-circuit current that will flow through the breaker. The module works with breakers that are rated on either “Total-Current” or “Symmetrical-Current” basis. The module computes the ANSI X/R – Ratio and adjusts the short-circuit current to account for asymmetry. The adjusted short-circuit current is then compared to the rated capabilities of the breakers based on a threshold value. Breakers that are rated above the threshold value are indicated with a warning flag that is generated by module.

Analysis:

The following cases were evaluated for this project:

Case 1 The short-circuit program was used to determine the three-phase and single-phase fault duties at the 13.8 kV bus (Bus No. 7508) at Derwood, Sub. 209. The ANSI X/R Ratio was also determined.

(Existing Condition – No PJM #S01 Generation)

Case 2 The short-circuit program was used to determine the three-phase and single-phase fault duties at the 13.8 kV bus (Bus No. 7508) at Derwood, Sub. 209. The ANSI X/R Ratio was also determined.

(With PJM #S01 Generation, 1.025MVA)

Conclusion:

The following are conclusions derived from adjustments made to short circuit duty by utilizing the ANSI C37.010 STD X/R Ratio. Per IEEE STD C37.010 – 1999, multiplying factors that include only DC decrements effects were used for non-generating station buses with a contact parting time of 3 cycles for 5 cycle breakers which include 0.5 cycles of relay time.

1. The addition of the 1.025MVA Gude Landfill generation project, PJM #S01 at Derwood, Sub. 209 will not overduty the 13.8 kV circuit breakers.

Note: The conclusions derived from this study are based on customer supplied estimated impedance values for the proposed equipment additions. If actual impedance values are less than the estimated values, any resulting ramifications will be at the expense of the customer.

Case 1 (Existing Condition)					
Bus No: & Location	Three – Phase				Breaker Rating (kA)
	Bus Voltage (kV)	Actual Duty (kA)	ANSI X/R Ratio	Estimated Adjusted Duty (kA)	
7508 Derwood	13.8	19.3	14.7	19.3	30.4
	Single - Phase				
7508 Derwood	13.8	22.0	16.6	22.0	35.0

Case 2 (With PJM #S01 1.025MVA Generation)					
Bus No: & Location	Three – Phase				Breaker Rating (kA)
	Bus Voltage (kV)	Actual Duty (kA)	ANSI X/R Ratio	Estimated Adjusted Duty (kA)	
7508 Derwood	13.8	19.5	14.8	19.5	30.4
	Single - Phase				
7508 Derwood	13.8	22.3	16.6	22.3	35.0

Note: Fault Duties adjusted based on ANSI C37.010 STD X/R Ratio.