

***Combined Feasibility/System Impact Study
Report***

***PJM Generation Interconnection Request
Queue Position #U2-070***

***Somerset
7.5MW
(.98MW capacity)***

November 2008

Preface

The intent of the Generation Interconnection Feasibility Study and the System Impact Study is to determine a plan, with cost and construction time estimates, to connect the subject Generation Interconnection Request to the PJM network at a location specified by the Interconnection Customer. As a requirement for interconnection, the Interconnection Customer may be responsible for the cost of constructing Network Upgrades, which are facility additions, or upgrades to existing facilities, that are needed to maintain the reliability of the PJM system. All facilities required for interconnection of a Generation Interconnection Request must be designed to meet the technical specifications (located on the PJM web site: <http://www.pjm.com/planning/trans-standard.html>) for the appropriate Transmission Owner. It must be noted that this project is currently interconnected to the FirstEnergy system and the requirements for connection to the FirstEnergy system have been met, therefore no changes have been identified as being required for this project during this study.

In some instances an Interconnection Customer may not be responsible for 100% of the identified Network Upgrade cost because other transmission network uses, e.g. another generation interconnection or merchant transmission upgrade, may also contribute to the need for the same network reinforcement.

The study estimates do not include the feasibility, cost, or time required to obtain property rights and permits for construction of the required facilities unless noted in the report. The project developer is responsible for acquiring any necessary right of way and real estate, as well as applying for and obtaining construction permits unless prior agreement by interested parties allows for other arrangements. For properties currently owned by Transmission Owners, some costs may be included in the study.

Cost and Timing Estimates

The estimates in this report do not include tax gross-up.

While the information in this transmittal is reasonable for the scope of work defined, it should, however, be noted that the cost figures and time estimates are conceptual in nature at this stage, as an engineering team has not been assigned to the project. Any change to the scope of work will require that the estimates be revisited. The costs are a best estimate, but the Interconnection Customer will be charged for actual costs. Any under-runs or over-runs will be reconciled at the conclusion of the project.

General

The Queue Position #U2-070 project was studied a 7.5MW (.98MW capacity) injection into First Energy's system. It was studied as two options with two different Points of Interconnection: Option 1 is a direct connection to the Allegheny #2 23kV bus (See figure 1), while Option 2 is a direct connection to the Meyersdale North #1 23kV bus (See figure 2). Project U2-070 was evaluated for compliance with reliability criteria for summer peak conditions in 2012.

The proposed upgrade must be designed in accordance with the FirstEnergy "Requirements for Transmission Connected Facilities" document.

Located at: <http://www.pjm.com/planning/trans-standard.html>

Metering

The Interconnection Customer will be required to maintain metering and telemetry equipment to provide revenue metering and real-time telemetry data to PJM and the Transmission Owner. The PJM requirements for this equipment are listed in Appendix 2, section 8 of Attachment O to the PJM Tariff, as well as PJM Manuals 01 and 14D.

The generation owner is responsible for specifying appropriate equipment and facilities such that the parallel generation is compatible with the FirstEnergy Transmission System. The generation owner is also responsible for meeting any applicable federal, state, and local codes. It is also the developer's responsibility to obtain any needed right-of-way between the plant site and FirstEnergy's facilities.

FirstEnergy may complete detailed relay coordination studies to identify off-site relay setting changes required due to this generation interconnection during the Facilities Study phase of this project. This may result in additional individual relay replacements being required. These relay replacements will be done at the cost of the developer.

Direct Connection Facilities

Connection to the Allegheny Substation would be through a 23 kV breaker attached to #2 bus (see Figure 1).

The proposed Interconnection Facilities must be designed in accordance with the FirstEnergy "Requirements for Transmission Connected Facilities" document. Procedures for gaining access to these standards can be found at the link below.

<http://www.pjm.com/planning/trans-standard.html>

Below are conceptual estimates for the engineering/construction associated with Direct Connection requirements based upon similar projects that have been designed and/or constructed.

Option #1

| Item | Description | Conceptual Cost Estimate |
|------|---|--|
| 1 | New 23 kV breaker termination point at Allegheny substation. | \$221,600 |
| 2 | 23 kV transmission line extending from Allegheny substation structure to the generation plant substation. | Developer cost. Line built, owned and maintained by the developer. |

Conceptual Estimate:

\$221,600

Estimated Lead Time:

1.0 years from signed CSA

Connection to the Meyersdale North Substation would be through a 23 kV breaker attached to #1 bus (see Figure 2). Connection costs would be similar to Allegheny Substation but will also require additional 115 kV relaying costs not required at Allegheny Substation.

Notes:

Detailed Engineering & Construction Estimates TBD via Facility Study.

The above estimates do not include 1) tax gross-up, 2) property costs and site development up to rough grade which is to be provided by the developer, 3) interconnection metering and generation SCADA to be provided by the developer, 4) engineering and field activities for design review and commissioning of the developer’s facilities, and 5) Real estate costs that may be required for right-of-way easements to extend the 23 kV line.

Potential network impacts were as follows:

OPTION 1: Allegheny #2 23kV

Generator Deliverability

None identified

Multiple Facility Contingency

None identified

Contribution to Previously Identified Overloads

(This project contributes to the following contingency overloads, i.e. "Network Impacts", identified for earlier generation or transmission interconnection projects in the PJM Queue)

None identified

Short Circuit

No problems identified

OPTION 2: Meyersdale North #1 23kV

Generator Deliverability

None identified

Multiple Facility Contingency

None identified

Contribution to Previously Identified Overloads

(This project contributes to the following contingency overloads, i.e. "Network Impacts", identified for earlier generation or transmission interconnection projects in the PJM Queue)

None identified

Short Circuit

No problems identified

Figure #1

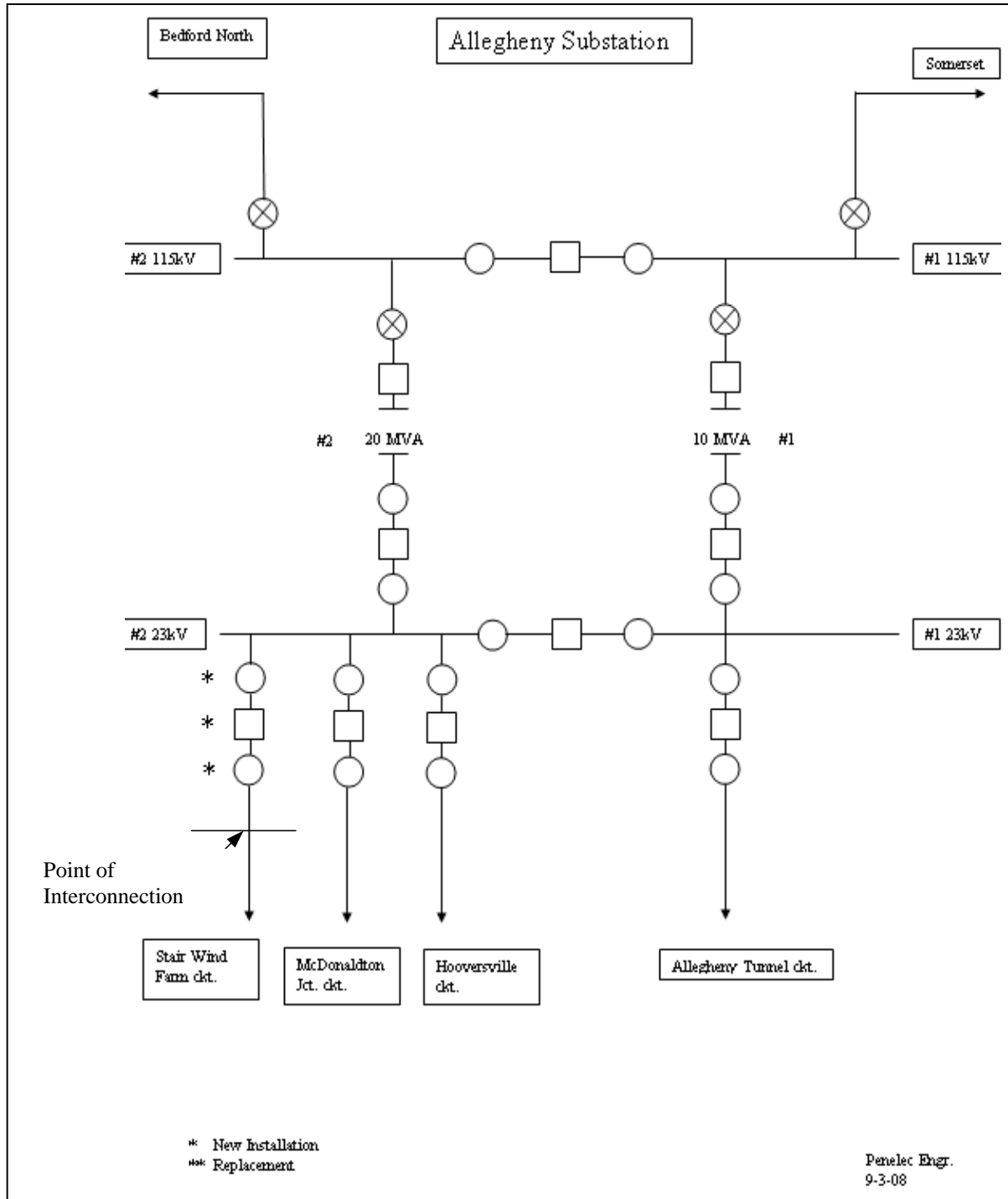
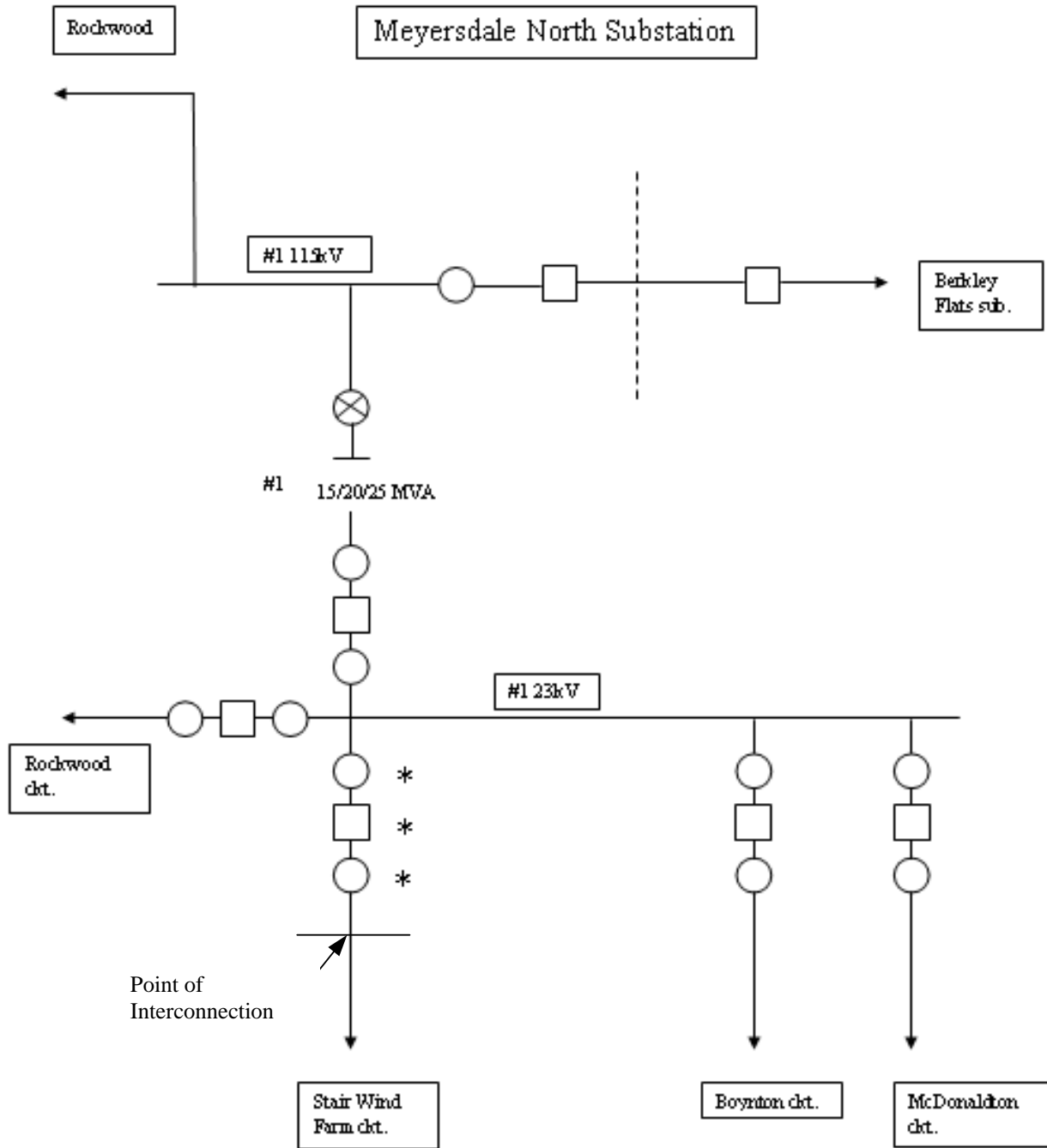

Figure #2



- * New Installation
- ** Replacement

Penelec Engr.
9-3-08