

# **PJM Combined Feasibility / Impact Study**

**34.5 kV Transmission Connection**

**for**

**Solar Cap, LLC**

**Britten Road Generation Project (U3-32)**

**April, 2009**

***FirstEnergy***

*Transmission Group*

**Prepared by  
FirstEnergy Corp  
Energy Delivery, Planning and Protection Department**



# **FirstEnergy Combined Feasibility / Impact Study**

## **Britten Road (U3-32) Generation Project**

### **Introduction**

This report provides the documentation of an RTEP system assessment performed by FirstEnergy (FE) in response to a request made by Solar Cap, LLC for the connection of a 20 MW Britten Road (U3-32) solar generation project to the Jersey Central Transmission System. As per the PJM RTEP study process, the Britten Road Project assessment was accomplished by: 1. Evaluating the reliability impact of the proposed facilities and connection on the interconnected transmission system by the performance of a power flow study; 2. Ensuring a compliance with the NERC, ReliabilityFirst, PJM and FE Reliability Standards by identifying the system reinforcements that will need to be installed for an interconnection of the proposed project; 3. Coordinating and cooperating with the PJM staff and Solar Cap, LLC by conducting meetings and issuing this report as a part of the RTEP study process; 4. Performing a Steady State, Short-Circuit and Dynamics Study as necessary; 5. Conducting all studies in accordance with the PJM Manuals, the "FE Requirements for Transmission Connected Facilities", and the "FE Study Guide".

### **Connection Facilities**

Solar Cap, LLC has submitted a "Form of Generation Interconnection Feasibility Study Agreement" to the PJM Interconnection, L.L.C. (PJM) that identifies its plan to construct a solar generation project at a location near Britten Road in Chatham New Jersey. While the total capability of this Britten Road Project is 17 MW, it will only be considered as a 6.5 MW capacity resource as per the PJM Manuals. As defined, the location of the collector substation for the Britten Road project will be remote from the requested connection point to the Jersey Central transmission system. This will require the construction of a radial attachment line of about 1 mile from the project site to the Green Village 34.5 kV substation.

A critical issue impacting on this project is the fact that the proposed Green Village 34.5 kV attachment substation is located directly adjacent to the federally protected Great Swamp National Wildlife Refuge as well as a natural gas pipeline. In an attempt to avoid the environmental and physical constraints that would need to be overcome, Solar Cap, LLC has consented to reducing the capability of the proposed generation project to 17 MW to qualify for a tapped connection option as defined in the FE Requirements for Transmission Facility Connection document. In addition, Solar Cap, LLC has proposed an over-build of the existing Jersey Central 12.5 kV distribution circuit emanating from the Green Village substation for the project connection. The implementation of this plan will require a reconstruction of this distribution line for a double circuit 34.5 kV and 12.5 kV operation. FE has agreed to this Solar Cap, LLC proposal in principle; but with reservation given the environmental constraints that exist. For example, it is assumed that the entrance

road to the Green Village substation is of sufficient size and stability to accommodate any new equipment and construction traffic. If the road needs to be enhanced, there may be significant permitting requirements that must be addressed. With respect to the installation/overbuild of the Jersey Central distribution lines, to the extent that any work is conducted in wetlands and/or transition areas it is further assumed that it can be done either by securing a Wetlands General Permit GP-21 with a transition area waiver or possibly by invoking our existing Wetlands GP-1 maintenance permit - depending upon the extent and location of new pole installations. Again, this could have a profound impact on the viability and cost of the proposed over-build if permitting becomes an issue. In addition, other permits such as a Soil Erosion and Sediment Control Plan Certification and the securing of a Storm Water General Permit may be required depending upon the size of any ground disturbance required to construct the project facilities. The SCD Certification would be needed if the total disturbance exceeds 5000 square feet and the Storm Water Permit will be needed if the disturbance exceeds 1 acre. This is another issue that may impact on the project. Nevertheless, Solar Cap, LLC will be required to provide any additional right-of-way, properties and permits that are required for this project and assume all risk for contingencies that occur. This Feasibility Study will therefore only focus on the facilities that are required to connect this project and ignore the environmental challenges presented. These issues will be addressed once the project proceeds on to the construction stage.

For the purposes of this study, the proposed project connection plan will be based on the drawings included on Attachments 1 and 2. As shown, Attachment 1 provides an overview of the geographic area near the Green Village substation and highlights the proposed radial connection line that will be needed. Attachment 2 shows a simplified one-line diagram of the Green Village 34.5 kV substation with the upgrades needed for the direct connection of the Britten Road project. This includes a new 34.5 kV breaker and switches for the new line position. In addition, a 1 mile radial 34.5 kV attachment line will be built from the Green Village substation to the Project site that will be overbuilt on the existing 6 wire distribution circuit. Note that once constructed, Jersey Central will own the radial connection line that is strung on the shared double circuit structures. However, the Point of Interconnection will be at the Green Village substation. As such, this report will only provide cost estimates for the Green Village substation upgrades and the transmission facilities that will be owned by FE. A summary of the network reinforcements that will be an FE responsibility are listed in the Facility Upgrades and Cost section of this report.

### **Power Flow Analysis**

A Power Flow study was conducted to determine the reliability impact of the proposed Britten Road Project on the FE Transmission System. This study was completed using a 2013 summer peak load base case power flow that was provided by the PJM staff. It contains a detailed representation of the Jersey Central 34.5 kV system in the area near the Green Village connection point. The FE review of the Britten Road project included a contingency analysis to identify any facility loading

or voltage condition that violates the ReliabilityFirst, PJM or FE Planning Criteria. The results of the FE analysis show that there are no criteria violations attributable to this project. Therefore no Network Upgrades will be required for the deliverability of the Britten Road Project generation to the PJM system.

### **Short Circuit and Dynamics Analysis**

A short circuit analysis was conducted by PJM and confirmed by the FE Protection staff. This analysis showed that no FE circuit breaker will exceed its interrupting capability with the implementation of the Britten Road project. Therefore no network reinforcements will be required.

### **System Protection Analysis**

An analysis was conducted to assess the impact of the Britten Road Project on the system protection requirements in the area. The results of this review have identified the following minimum requirements:

#### **Green Village 34.5 kV Substation**

1. Construct a new control building or expand the existing one to accommodate the relays required for the direct connection facilities. As an alternative, it may be possible to install a breaker containing an integral relay and control panel. While FE will assume that this self-contained breaker option is feasible, a final determination will be made under subsequent study of this project.
2. The following relay equipment will be required:
  - One set of 3 Bus Potential Devices, Ratio 300/1
  - An SEL-321 relay
  - An SEL-311B relay
  - SATEC or equivalent metering.

Solar Cap, LLC will also be responsible for installing all project facilities at its generation substation in compliance with the FE and regional requirements. This includes unit over/under voltage protection, over/under frequency protection, zero sequence voltage protection as may be required. Solar Cap, LLC will also be responsible for all leasing costs for the communication circuits that may be required for the communication of data to PJM. FE will not provide a cost estimate for these facilities as a part of this report.

### **Metering**

Solar Cap, LLC will be required to comply with all FE Revenue Metering Requirements for Generation Interconnection Customers. These FE requirements are detailed on Attachment 3 to this report. This is in addition to any PJM requirements.

## **Compliance Issues**

Solar Cap, LLC will be responsible for meeting all criteria defined in the "FE Requirements for Transmission Connected Facilities" document that is posted on the PJM and FE web sites. This includes the provision of a reactive power capability sufficient to maintain a composite power delivery for the facility at the interconnection point at a power factor between .95 leading (absorbing MVARs) and .90 lagging (producing MVARs). Since the proposed solar generation project will provide no reactive power, Solar Cap, LLC will be required to install a 5.9 MVAR switched capacitor to provide an equivalent amount of reactive compensation. Its operation will be directed by the FE Regional System Dispatcher.

Solar Cap, LLC will also need to meet all PJM, ReliabilityFirst and NERC reliability criteria and operating procedures for standards compliance. For example, Solar Cap, LLC must properly locate and report the over and under-voltage and over and under-frequency system protection elements for its project as well as submit the generator model and system protection data when requested by PJM and ReliabilityFirst when audits are performed. A failure to comply with these requirements may result in a disconnection of service if the violation is found to compromise the reliability of the FE system.

## **FE Facility Upgrades and Costs**

The results of the FE analysis shows that no FE planning criteria violations are attributable to the addition of the Britten Road project for the conditions studied. Therefore the conclusion is that no transmission reinforcements will be required to provide the requested service.

The following is a summary of the FE facilities that will be required for the direct connection of the Britten Road Generation Project:

1. Construct a radial double circuit 34.5 kV and 12.5 kV transmission line for the project attachment. This includes design & engineering, materials, construction, right-of-way acquisition, vegetative clearing, all distribution system and cable transfers, and flagging on Green Village Road. The cost estimate developed assumes a starting point at the Green Village substation, an exit out of the substation extending down the access road, a turn onto Green Village Road and a final turn onto Britten Road to pole JC667CMT. The estimated total distance of this path is 5600'. This is the value that was used when developing the cost estimates in this report. A more accurate measurement will be determined as a part of subsequent study of this project. (Cost Estimate \$1,265,000)
2. Install a new 34.5 kV breaker, switches, CVT and line position at the Green Village substation for the proposed generator attachment line. (Cost Estimate \$658,000)

*All cost data contained in this document should be considered estimated. The applicant will be responsible for the actual cost of construction. FE herein reserves*

*the right to return to any issues in this document and, upon appropriate justification, request additional monies to complete any connections to the transmission system.*

### **Solar Cap, LLC Requirements**

Solar Cap, LLC will be responsible for constructing the 34.5 kV line extension from the Jersey Central pole JC667CMT to its collector substation and all facilities required at this site. Solar Cap, LLC will also be responsible for meeting all criteria as specified in the applicable sections of the "FE Requirements for Transmission Connected Facilities" document including:

1. The purchase and installation of the minimum required FE generation interconnection relaying and control facilities.
2. The purchase and installation of a 34.5 kV interconnection metering instrument transformer. FE will provide the ratio and accuracy specifications based on the customer load and generation levels.
3. The purchase and installation of a revenue class bi-directional meter to measure the power delivery from the Solar Cap, LLC units in compliance with the FE standards.
4. Since no backup 34.5 kV service has been requested, a reverse power relay must be installed to disconnect the project whenever an energy flow from the Jersey Central 34.5 kV system is detected. As an alternative to this relay, Solar Cap, LLC has the option of executing a tariff agreement with Jersey Central that will specify the charges for any capacity and energy service that is provided.
5. The purchase and installation of supervisory control and data acquisition (SCADA) equipment to provide information in a compatible format to the FE Transmission System Control Center.
6. The establishment of dedicated communication circuits for SCADA report to the FE Transmission System Control Center and for dialup access to revenue metering.
7. A compliance with the FE and PJM generator power factor and voltage control requirements. This may include the installation of a switched shunt capacitor bank if the units do not meet the established design criteria.
8. The installation of a 5.9 MVAR capacitor bank.

The above requirements are in addition to any metering required by PJM.

## **Summary**

The direct connection of the Britten Road generation project to the FE transmission system will require the addition of a breaker position at the Green Village substation and the rebuild of a Jersey Central distribution line for double circuit operation. The total estimated cost of these upgrades is \$1,923,000. Based on the power flow studies performed, no Network Upgrades will be required. Solar Cap, LLC will be responsible for the extension of the attachment 34.5 kV line to the Britten Road substation. The Britten Road substation must be constructed in compliance with the "FE Requirements for Transmission Connected Facilities" document requirements. This includes the installation of a 5.9 MVAR capacitor to provide in lieu of the generator not meeting the FE power factor criteria.

Based on the extent of the FE direct connection upgrades required to support this project, it is expected to take a minimum of one (1) year from the signing of a Connection Service Agreement to complete the upgrades required for the Britten Road project. This assumes that Solar Cap, LLC provides all right-of-way, permits, easements, etc. that will be needed for the attachment line. It also assumes that there will be no delays in acquiring the permits that will be needed for the new foundations and structures required for the direct connection facilities at the Green Village substation.

Note that the FE findings were made from a conceptual review of this project. A more detailed review of the connection facilities and their cost will be identified during subsequent study of this project when the exact location of the Britten Road substation is defined.

**Attachment 1**  
**Britten Road (U3-032) RTEP Project**  
**(Overview)**



## Attachment 2

### Britten Road (U3-032) RTEP Project

### Green Village 34.5 kV Substation

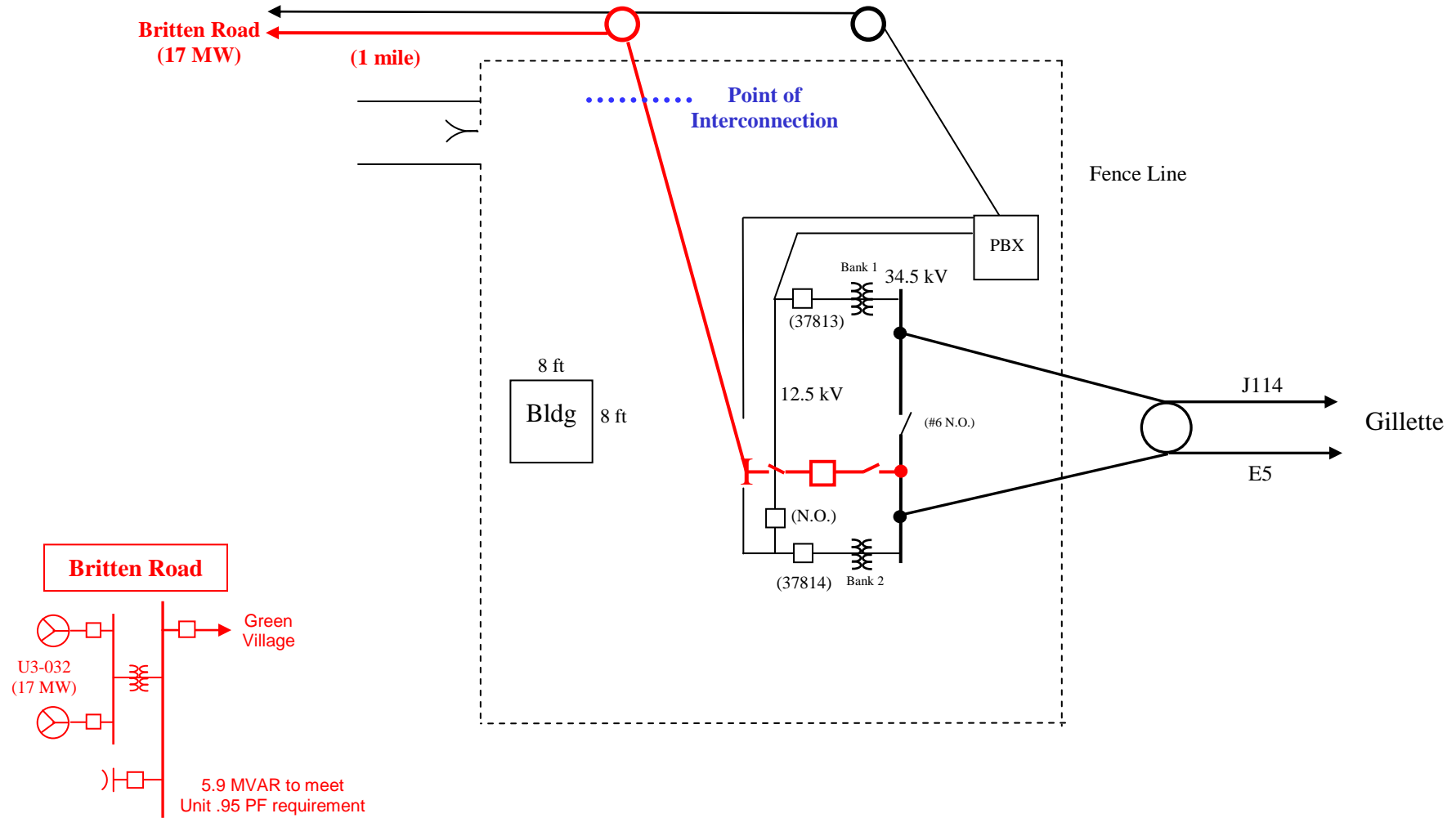

## Attachment 3

### **FirstEnergy Revenue Metering Requirements for Generation Interconnection Customer**

Interconnection Customer shall install, own, operate, test and maintain the necessary revenue quality Metering Equipment. This includes current transformers, voltage transformers, mounting structures, wiring, meters, communication circuits, and associated devices. The Metering Equipment must meet the specifications listed in the FirstEnergy and regional transmission organization (RTO) connection documents. The FirstEnergy "Requirements for Transmission Connected Facilities" are located at: <http://www.firstenergycorp.com/feconnect>

The Metering Equipment shall be located at the generation facility on the high voltage side of the generator step-up transformers or facility main step-up transformer and/or station service power transformers. Power flows to and from the facility shall be compensated to the Point of Interconnection.

FirstEnergy will provide revenue quality Metering Equipment for a station service power supply at a generation facility if the supply is from the local FirstEnergy distribution system.

The revenue quality Metering Equipment shall be capable of collecting and storing bidirectional billing data. The billing data shall be stored in intervals specified by FirstEnergy, typically fifteen minutes or thirty minutes. The Interconnection Customer must provide FirstEnergy with remote access to the billing data in the Metering Equipment via a dedicated voice-grade analog telephone circuit. The Interconnection Customer shall provide FirstEnergy with contact information for the person or persons responsible for meter programming and Metering Equipment maintenance.

The Interconnection Customer shall consult with FirstEnergy regarding the revenue quality metering system design and provide the following information:

- Facility one line and revenue metering installation drawings (schematics, wiring diagrams, etc.)
- Estimated power flows to and from the facility at all revenue metering points
- Current transformer and voltage transformer specifications, including manufacturer, type, nameplate drawings, and certified accuracy test reports
- Revenue meter specifications including manufacturer, type, model number, and accuracy
- Revenue meter program information including but not limited to billing data recorder channel assignments, recorder pulse weights (Ke), and read-only password for access to interval data by the FirstEnergy billing data collection system (MV-90)
- Revenue meter telephone number
- Revenue meter loss compensation data (if applicable)

The Interconnection Customer shall provide FirstEnergy with prior notification of any modifications at the facility that will affect the revenue meter measurements, including substation reconfigurations and meter program changes.

The revenue metering system at each location shall be tested for accuracy by the Interconnection Customer once every two years. The Interconnection Customer shall give reasonable notice to FirstEnergy of the time when the testing is scheduled so that FirstEnergy may have representatives present. FirstEnergy and the RTO shall have the right to audit the revenue metering equipment and/or related documents. The Interconnection Customer shall be given a reasonable period of time to comply with any requests associated with an audit.