

***Generation Interconnection
Combined Feasibility/System Impact Study
Report***

For

***PJM Generation Interconnection Request
Queue Position V2-003***

Beasley 23kV

January 2010

Preface

The intent of the Combined Feasibility/System Impact Study is to determine a plan, with approximate cost and construction time estimates, to connect the subject generation interconnection project to the PJM network at a location specified by the Interconnection Customer. As a requirement for interconnection, the Interconnection Customer may be responsible for the cost of constructing: Network Upgrades, which are facility additions, or upgrades to existing facilities, that are needed to maintain the reliability of the PJM system. All facilities required for interconnection of a generation interconnection project must be designed to meet the technical specifications (on PJM web site) for the appropriate transmission owner.

In some instances an Interconnection Customer may not be responsible for 100% of the identified network upgrade cost because other transmission network uses, e.g. another generation interconnection or merchant transmission upgrade, may also contribute to the need for the same network reinforcement. The possibility of sharing the reinforcement costs with other projects may be identified in the Feasibility Study, but the actual allocation will be deferred until the System Impact Study is performed.

The Study estimates do not include the feasibility, cost, or time required to obtain property rights and permits for construction of the required facilities. The project developer is responsible for the right of way, real estate, and construction permit issues. For properties currently owned by Transmission Owners, the costs may be included in the study.

General

RC Cape May Holdings, LLC, the Interconnection Customer (IC), has proposed a 4 MWE (1.52 MWC) solar powered generating facility consisting of four (4) one (1) MW inverters. The facility will be located on a site adjacent to the BL England generating station in Marmora, New Jersey. V2-003 was studied as a 4 MW injection into the Atlantic City Electric's (ACE) distribution system between the Beasley and BL England 23kV substations and was evaluated for compliance with reliability criteria for summer peak conditions in 2013.

Point of Interconnection

V2-003 will interconnect with the Atlantic City Electric distribution system at the England 138/23kV substation (see Attachment 1).

Direct Connection Requirements

Transmission Owner Scope of Direct Connection Work

The scope of work and estimated costs for the direct connection facilities is as follows:

1. The construction of a new approximate 0.5 mile 23kV dedicated feeder with aerial cable to be built between the IC's generating site and the England 138/23kV substation. The estimated cost to perform this work is **\$300,000**.

2. A feeder terminal will be created at the England 138/23kV substation for the new dedicated 23kV feeder. The estimated cost to perform this work is **\$300,000**.
3. A utility operated recloser will be required on the IC tap that will have proper relaying and communication. The estimated cost to perform this work is **\$50,000**.
4. Utility grade primary metering will be required. The estimated cost to perform this work is **\$20,000**.
5. A SCADA point addition to Control Center will be required. The estimated cost to perform this work is **\$10,000**.
6. System protection planning. The estimated cost to perform this work is **\$15,000**.

The total estimated cost to perform the above work is **\$695,000**. The estimated time to complete the work is **6 to 12 months** following receipt of a fully executed Interconnection Services Agreement and Interconnection Construction Service Agreement. Schedule and costs to be refined during the Facilities Study phase of the project.

Note: the above cost does not include the Contribution in Aid of Construction (CIAC) tax.

Interconnection Customer Scope of Direct Connection Work

The Interconnection Customer assumes full responsibility for design and construction of all facilities associated with the V2-003 generating station on their side of the POI. Site preparation including grading and an access road, if necessary, is assumed to be by the IC.

The IC will be required to install metering and telemetry equipment to provide revenue metering and real-time telemetry data to PJM. The requirements for this equipment are listed in Appendix 2, Section 8 of Attachment O to the PJM Tariff, as well as PJM Manuals 01 and 14D. Protective relaying and metering design and installation must comply with Atlantic City Electric Applicable Standards.

Network Impacts

Potential transmission network impacts are as follows:

Generator Deliverability

*(Single or N-1 contingencies for the **Capacity** portion only of the interconnection)*

None

Multiple Facility Contingency

(Double Circuit Tower Line, Line with Failed Breaker and, Bus Fault contingencies for the Full energy output.

None

Contribution to Previously Identified Overloads

(This project contributes to the following contingency overloads, i.e. “Network Impacts”, identified for earlier generation or transmission interconnection projects in the PJM Queue)

None

Short Circuit

Not required.

New System Reinforcements

(Upgrades required to mitigate reliability criteria violations, i.e. “Network Impacts,” initially caused by the addition of this project’s generation)

None

Contribution to Previously Identified System Reinforcements

(Overloads initially caused by prior Queue positions with additional contribution to overloading by this project.

None

Dynamic Analysis

The dynamic study is in progress and will be completed during the Facilities Study phase of V2-003. The IC may be required to provide dynamic VAR compensation as a result of the study. The study may identify the need for additional system equipment, settings, distribution system reinforcements, and possibly Point of Interconnection alternatives.

V2-003

England 138/23 kV Sub

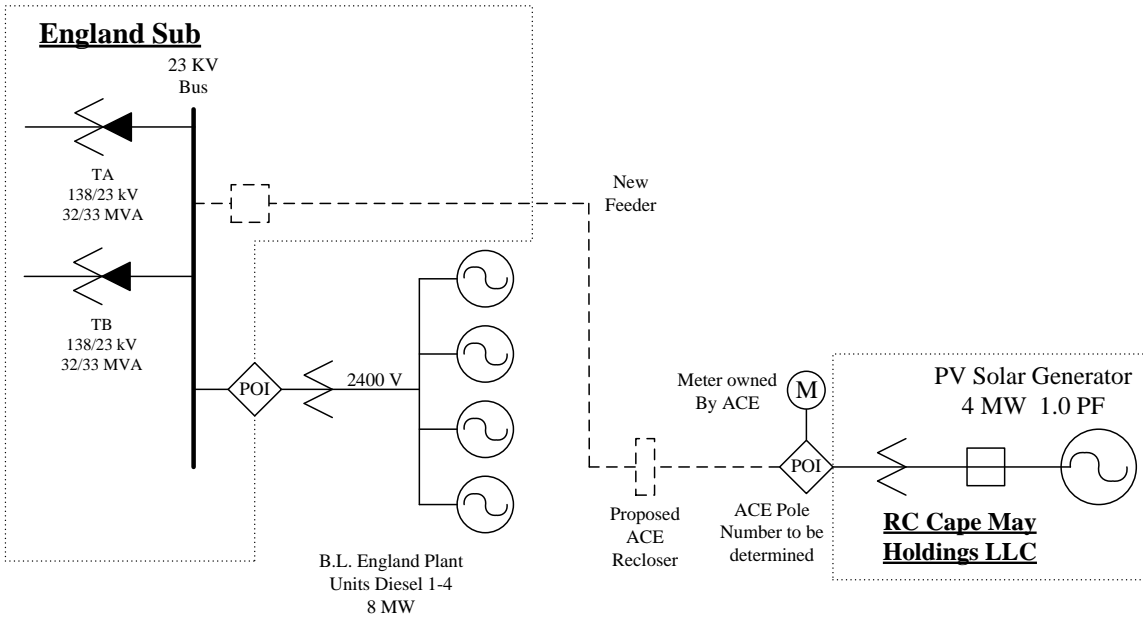

***Generation Interconnection
Combined Feasibility/System Impact Study
Report
(PJM portion)***

For

***PJM Generation Interconnection Request
Queue Position V2-003***

Beasley 23kV

October 2009

Preface

The intent of a Combined Feasibility/System Impact Study is to determine a plan, with approximate cost and construction time estimates, to connect the subject generation interconnection project to the PJM network at a location specified by the Interconnection Customer. As a requirement for interconnection, the Interconnection Customer may be responsible for the cost of constructing: Network Upgrades, which are facility additions, or upgrades to existing facilities, that are needed to maintain the reliability of the PJM system. All facilities required for interconnection of a generation interconnection project must be designed to meet the technical specifications (on PJM web site) for the appropriate transmission owner.

The following report documents the PJM results of the Combined Feasibility/System Impact Study for V2-003, Beasley 23kV. It does not include the Transmission Owner's (TO) results which will be provided under separate cover. No transmission network impacts were found.

General

RC Cape May Holdings, LLC, the Interconnection Customer (IC), has proposed a 4 MWE (1.52 MWC) solar powered generating facility consisting of four (4) one (1) MW inverters. The facility will be located on a site adjacent to the BL England generating station in Marmora, New Jersey. V2-003 was studied as a 4 MW injection into the Atlantic City Electric's (ACE) distribution system between the Beasley and BL England 23kV substations and was evaluated for compliance with reliability criteria for summer peak conditions in 2013. The planned in-service date is December 31, 2009.

Point of Interconnection

V2-003 will interconnect with the Atlantic City Electric distribution system via a tap of the BL England-Beasley 23kV (See Attachment 1 for simple single line).

Direct Connection Requirements

Transmission Owner Scope of Direct Connection Work

To be provided with TO's results.

Interconnection Customer Scope of Direct Connection Work

The Interconnection Customer (IC) has assumed full responsibility for the design and construction of all facilities associated with the V2-003 generating facility and the 23kV direct connection line on the IC side of the Point of Interconnection (POI). The IC will interconnect V2-003 with the ACE distribution system by constructing a customer-owned 23kV line from the generating facility to AEC's distribution network. Route selection, line design, right-of-way acquisition and construction of such lines will be entirely the responsibility of the IC.

The IC will be required to install metering and telemetry equipment to provide revenue metering and real-time telemetry data to PJM. The requirements for this equipment are listed in Appendix 2,

Section 8 of Attachment O to the PJM Tariff, as well as PJM Manuals 01 and 14D. Protective relaying and metering design and installation must comply with Atlantic City Electric Applicable Standards.

Network Impacts

Potential transmission network impacts are as follows:

Generator Deliverability

*(Single or N-1 contingencies for the **Capacity** portion only of the interconnection)*

None

Multiple Facility Contingency

*(Double Circuit Tower Line, Line with Failed Breaker and, Bus Fault contingencies for the **Full** energy output.*

None

Contribution to Previously Identified Overloads

(This project contributes to the following contingency overloads, i.e. “Network Impacts”, identified for earlier generation or transmission interconnection projects in the PJM Queue)

None

Short Circuit

Not required.

New System Reinforcements

(Upgrades required to mitigate reliability criteria violations, i.e. “Network Impacts,” initially caused by the addition of this project’s generation)

None

Contribution to Previously Identified System Reinforcements

(Overloads initially caused by prior Queue positions with additional contribution to overloading by this project.

None

Stability Analysis

Not required.

Potential Congestion due to Local Energy Deliverability

(PJM also studied the delivery of the energy portion of the surrounding generation. Any potential problems identified below are likely to result in operational restrictions to the project under study. The developer can proceed with Network Upgrades to eliminate the operational restriction at their discretion by submitting a Transmission Interconnection Request. Note: Only the most severely overloaded conditions are listed below. There is no guarantee of full deliverability for this project by fixing only the conditions listed in this section. With a Transmission Interconnection Request, a subsequent analysis will be performed which analyzes all overload conditions associated with the identified overloaded element(s). As a result of the aggregate energy resources in the area, the following violations were identified:

None

Attachment 1
V2-003

