

***PJM Generator Interconnection
V3-023 Alburdis - Hosensack
500 MVAR SVC
Feasibility Study***

January 2010

DMS # 576299

General

Queue V3-023 is a Primary Power LLC (Tangibl) request to interconnect a 500 MVAR SVC (Static Var Control) near the Hosensack 500 kV Substation or on the Alburdis – Branchburg 500 kV line. Queue V3-023 has requested a June 1, 2013 in-service date. **This study does not imply a PPL EU commitment to this in-service date.**

Direct Connection Requirements

Queue V3-023 500 MVAR SVC can be connected directly to the Hosensack 500kV substation or on the Alburdis - Branchburg 500 kV line as shown on the one-line diagram below and described in the text that follows.

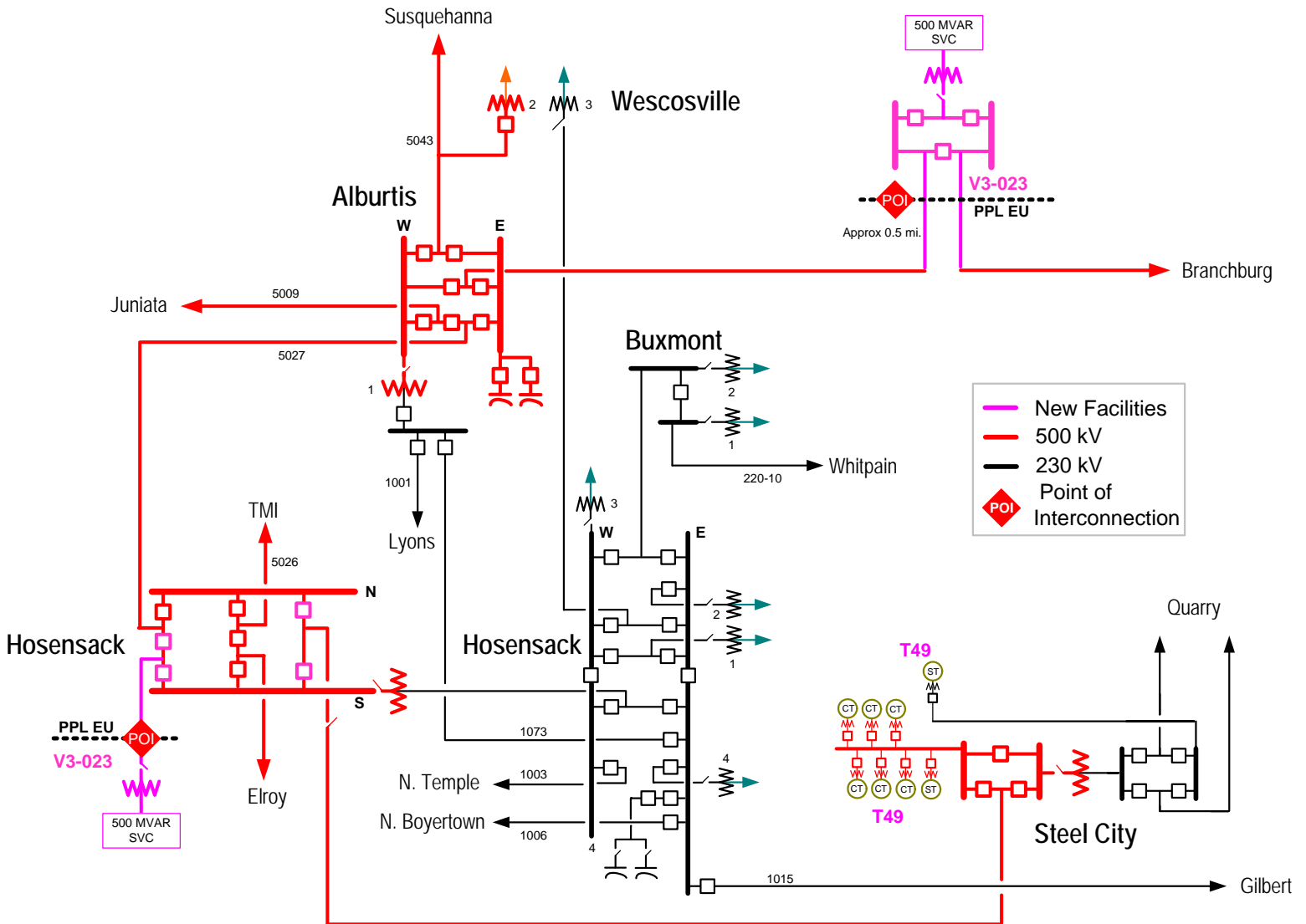

Interconnection Customer Scope of Direct Connection Work

Primary Power LLC is responsible for construction of all facilities on its side of the POI (Point of Interconnection) shown on the one line diagram of the previous page (page 2).

Metering / telemetering

It is anticipated that Revenue Metering would be required but that all metering equipment cost would be borne by PPL EU. The metering location would be decided at the time of design engineering.

The SVC project developer may be required to install the necessary equipment to provide telemetering. It is not known at this point in time what quantities would be exchanged or required.

Transmission Owner (PPL Electric Utilities) Scope of Direct Connection Work

Hosensack 500 kV Substation Option

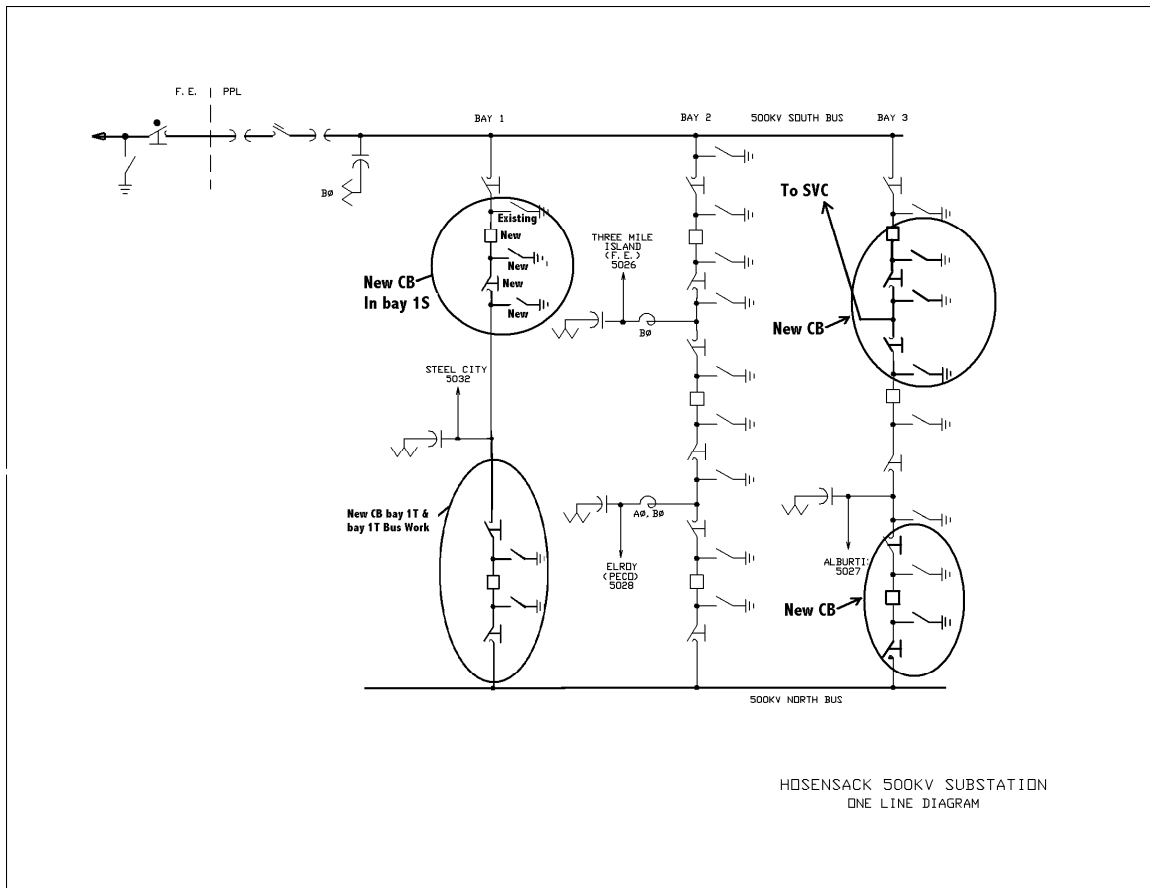

Connect the 500 MVAR SVC directly in to the Hosensack 500kV substation in bay 3 S, assuming the SVC site is located about ½ mile away from the Hosensack 500kV substation on a parcel of land owned by the Interconnection Customer.

The estimated direct connection magnitude cost is **\$13,756,400***

* Applicable state and federal taxes and R/W cost are not included.

Lead Time required is **30 months** from the start of the engineering to placing the project in-service.

A further breakdown of the cost and scope of work is as follows:

1. Transmission Direct Connection - \$ 2,126,400 (assumed 1/2 mile of 500kV line up to the Interconnection Customer's dead end structure)

The transmission direct connection cost includes construction of approximately ½ mile of 500 kV single circuit transmission line consisting of triple bundle 1590 Kcmil ACSR conductors from the Hosensack 500kV substation bay 3 south to the V3-023 dead end structure utilizing approximately 2-3 H-frame structures with two overhead ground wires. One overhead ground wire (OHGW) will be a 19 #9 Alumweld the other will be an OPGW carrying fibers for relay communication channels.

2. PUC filing Cost - \$30,000 (not including Siting cost)

Since the location of the SVC is not known and it would require purchase of a parcel of land from private land owners by the developer, PPL EU can't provide siting and R/W cost. If the developer procures a site for the SVC that is adjacent to the PPL EU Hosensack substation then PPL EU will be able to site the direct connection 500 kV line via its Hosensack substation if there are no insurmountable environmental issues.. If the SVC is located away from the Hosensack substation then any additional R/W required would be the developer's responsibility. Therefore PPL EU will not be providing the R/W cost estimate until the SVC location is determined by the developer. If the required R/W is obtained by the developer, then there will be no PPL EU cost borne by the developer. The R/W width required would be 200 ft and the length will depend on the location of the SVC site.

However, PA PUC certification filing will be required and it will be made through an abbreviated version of filing called "Letter of Notification" (LON) since the tap will be short (less than 2 miles long). Cost of this filing would be approximately \$30,000 and **it is included** in the above cost estimate. The elapsed time required for the filing preparation to PA PUC approval would be approximately 6 months.

These Siting estimates and schedule do not include any costs or time to litigate or mitigate significant environmental and cultural issues.

3. Substation Direct Connection - \$ 11,500,000 (Connection to the Hosensack 500kV bay 3 S and fiber channel for protective relaying)

- Install in bay 3 two new 500 kV dead tank circuit breakers in positions 3S and 3N including their associated motor operated disconnect (MODs) switches (two for circuit breaker 3N, one for circuit breaker 3S and one for the existing circuit breaker 3T) and other devices such as ground switches, CCVTs and surge arrestors as required. Retain the Alburdis line connection to bay 3N and connect the SVC in bay 3S. Additionally, install structures and foundations for new circuit breakers, new MODs and other associated devices as required including one 500kV line dead-end structure. The addition of the SVC would require conversion of the Hosensack 500 kV substation in to a breaker-and-one-half configuration.

- **Conversion to breaker-and-one-half configuration:**

If the SVC is simply connected into bay 3S with one additional breaker in bay 3S, the substation configuration will turn in to a 5 breaker ring bus which would not meet PPL EU's requirements for reliability, operability, and maintainability for the transmission system.

Hosensack 500 kV substation will be required to be expanded to a breaker-and-one-half arrangement which requires the addition of four more circuit breakers, two in bay 3N & S positions and two in bay 1 N & S positions, and re-termination of the Steel City line to bay 1N.

As a result, PPL EU will install two new 500 kV dead tank circuit breakers in positions 1S and 1N including their associated motor operated disconnect (MODs) switches (two for circuit breaker 1N and one for circuit breaker 1S) and other devices such as ground switches as required and re-terminate the Steel City 500kV line from south bay position to north bay position. Additionally it will be required to install structures and foundations for the circuit breakers, MODs, and other associated devices. (Note: The Steel City 500kV line is currently connected to bay 1 south bus but via the dead-end structure in the bay 1 north which makes it easy to re-terminate this line to bay 1 north)

- Install required relay and control packages at the Hosensack 500 kV substation.
- Modify and interface with the existing protection and control schemes, SCADA, Alarm Management System, etc. to allow SVC direct connection in to the new 500 kV bay 3S and modify bay 1 to convert the substation in to a breaker-and-one-half arrangement.

- Terminate Optical fibers from the OPGW for pilot relay communication channel.

4. Harmonics and Switching Studies - \$ 100,000

Perform engineering studies such as Harmonics, Switching Transients, etc. These studies will be combined with the Interconnection Customers existing studies for Queue U2-087 SVC interconnection. This estimate is provided in case additional funds are required over and beyond the fund allocation for the U2-087 study.

Alburtis - Branchburg 500 kV Line Option

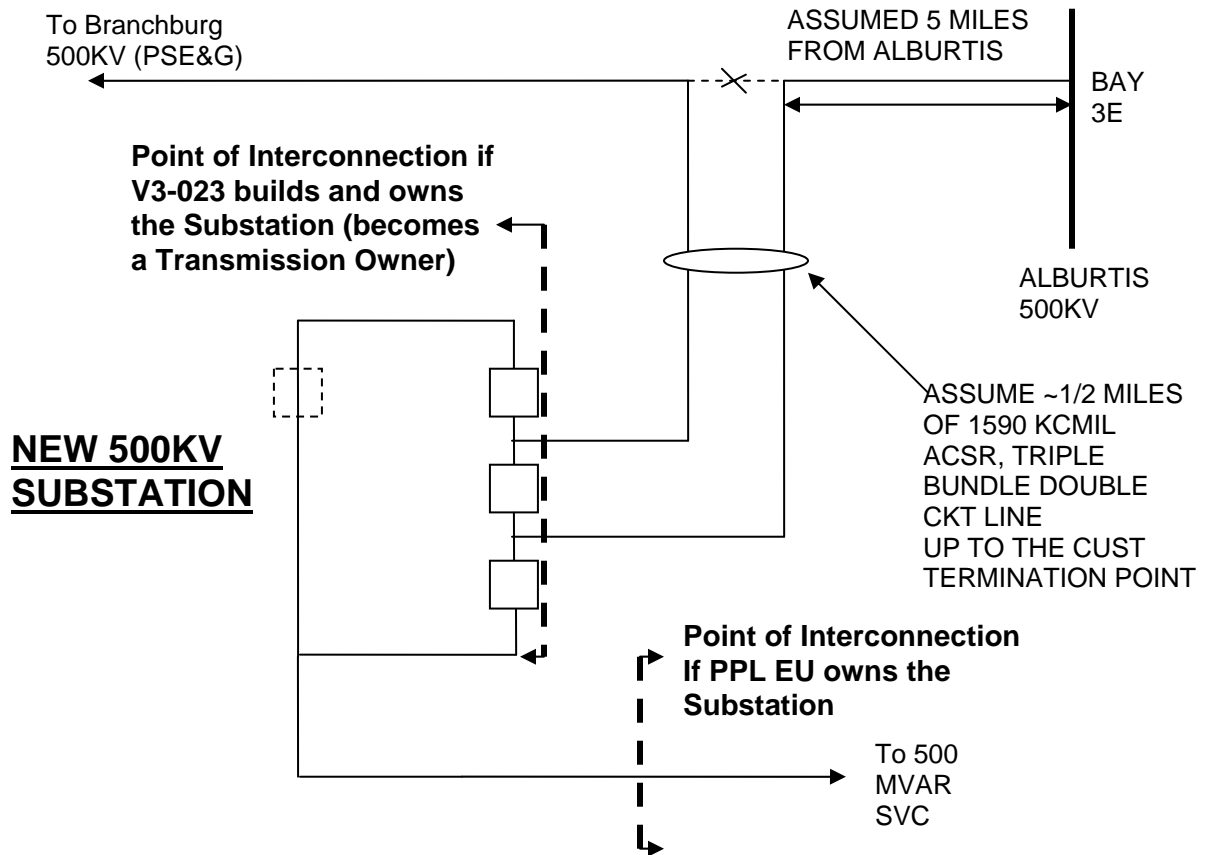

Connect the 500 MVAR SVC into the Alburtis - Branchburg 500 kV line about 5 miles (assumed) from the Alburtis 500 kV substation. 5 miles is assumed since the exact location of the SVC site is not known by the Interconnection Customer at this point in time. The estimated direct connection magnitude cost is:

\$4,868,600* (cost without PPL EU constructing the 3-breaker ring bus)

\$26,168,600* (cost if PPL EU constructs the new 500kV 3-breaker ring bus substation) (cost of new substation land, grading, site preparation, not included in this estimate).

* Applicable state and federal taxes are excluded.

Lead Time required is **36 months** from the start of the engineering to placing the project in-service.

A further breakdown of the cost and scope of work is as follows:

1. Transmission Direct Connection - \$ 2,697,600 (Assumes ~1/2 mile of a double circuit 500 kV line from the Alburdis – Branchburg sectionalizing point to the SVC site.)

The transmission direct connection cost includes construction of approximately 1/2 mile of 500 kV double circuit transmission line consisting of a triple bundle 1590 Kcmil ACSR conductors from the Alburdis - Branchburg 500 kV line sectionalizing point to the Interconnection Customer's dead end structure utilizing approximately 2-3 single shaft steel pole structures with two overhead ground wires. One overhead ground wire (OHGW) will be a 19 #9 Alumweld, the other will be an OPGW carrying fibers for the protective relaying communication channels.

Note: 1/2 mile length is assumed since the location of the SVC is not known by the Interconnection Customer at this point in time. If the line length is revised due to the location of the SVC installation, this cost would change accordingly.

2. Transmission OPGW (overhead fiber from Alburdis to sectionalizing point, 5 miles is assumed) - \$ 531,000

Relay protection for the short line section from Alburdis Substation to the Interconnection Customer's new substation will require the installation of a fiber Optic (OPGW) ground wire on that line section to provide relay communication. For the existing line section from the Interconnection Customer's new substation to Branchburg, the existing Alburdis – Branchburg Power Line Carrier type relay protection equipment can be retained. (Per mile OPGW fiber cost estimate is \$106,200)

3. Siting, Right of Way and PUC Filing Direct Connection - \$ 890,000 (assumes a 200 ft R/W for a 1/2 mile double circuit line and PUC filing)

Since the location of the SVC is not known, estimating R/W is difficult but PPL EU has made a magnitude estimate based on 1/2 mile of 200' generic R/W. There is no PPL EU cost if the R/W is obtained by the Interconnection Customer.

A PA PUC Certification filing will be required per the PA PUC regulations. If the line length is short (< 2 miles) it will only require a "letter of notification" (LON - an abbreviated version of the filing). If the line length is >2 miles a "full siting application" would be required. Since a line length of 1/2 mile was assumed, the associated cost estimate for a LON is \$30,000. The elapsed time required for the filing preparation to PA PUC approval would be approximately 6 months. If a full PUC Certification Filing is required it may take one year or longer. These time frames could increase due to intervention by public and other interested groups.

The above cost and time Siting estimates and schedules do not include any costs or time to litigate or mitigate significant environmental and cultural issues.

4. Substation Direct Connection - \$ 750,000 (Assumes Queue V3-023 Interconnection Customer builds the new 3 breaker 500 kV substation)

PPL EU substation work at Alburdis

- Cost to install any required relay and control equipment at the Alburdis 500 kV substation, \$250,000. Due to short line/long line scenario, dual pilot relay protection will be required for the line section from Alburdis Substation to the Interconnection Customer's new substation. It is assumed that the pilot relay communication channel will be Optical fiber imbedded in the over head ground wire (OPGW).
- Perform engineering studies such as Harmonics, Switching Transients, etc. These studies will be combined with the Interconnection Customers existing studies for Queue U2-087 SVC interconnection. This estimate is provided in case additional funds are required over and beyond the fund allocation for the U2-087 study. Additional \$100,000.

PSE&G substation work at Branchburg

- Cost to install any required relay and control equipment at PSE&G's Branchburg 500 kV substation is estimated at \$400,000 based on PPL EU's review. If the Alburdis – Branchburg 500 kV line interconnection option is selected PSE&G should provide the scope and cost estimate for the Impact Study.

It is assumed that for the existing line section from the Interconnection Customer's new substation to Branchburg, the existing Alburdis – Branchburg Power Line Carrier type relay protection equipment can be retained. The Branchburg work would be completed by PSE&G who owns the Branchburg 500kV substation.

The above estimates do not include any upgrade cost as result of problems identified due to the Harmonic and Switching Transients studies.

5. Substation Direct Connection - \$ 21,300,000 (If PPL EU constructs the new V3-023 Interconnection 3 breaker 500kV substation)

Since nothing is known on new substation site, PPL EU has made the following assumptions to provide a magnitude cost estimate.

- a) This option assumes that the project developer would provide a level substation site and initially graded of at least 400 X 650 feet for building the substation at their cost. NOTE: to avoid excessive line entrance costs, the developer should have an area set aside that will allow for the 400 by 650 foot switchyard to be oriented in any direction.

- b) The above “Site parcel” requirement does not provide any room for a detention basin or additional areas to be graded to accommodate surrounding contours landscapes. If detention basin required, additional parcel of land would be required.
- c) Substation orientation would be determined only after the site and the transmission R/W is known.
- d) The proposed sub site dimensions will be suitable for a 3 breaker ring bus but for an ultimate design of 3 bays in a breaker and one half arrangement.
- e) Install four 500 kV dead tank circuit breakers and associated motor operated disconnect switches (MODs, 2 per breaker required) and install all other associated equipment as required such as grounding switches, CCVT etc.. Install all required foundations and structures for the new substation.
- f) Install 500 kV line dead-end Structures and their foundations as required.
- g) Install ground grid as required
- h) Install Control Cubicle and all required protection and control equipment
- i) The entire site would be graded and stoned and fenced for three bays
- j) Final location and equipment layout design can be determined only after the site and line r/w is known.

Preliminary Schedule

The estimated PPL EU lead time required in completing the 500 kV substation work and the sectionalizing of the 500 kV line in to the customer’s substation is approximately **30 months**. If the 500 kV three breaker ring bus substation is built by PPL EU than the lead time would be **36 months**.

Common to Both Direct Connection Options

The required in-service date for the direct connection facilities would depend up on the project start date as well as the project start window due to outage requirements. PPL EU and PJM outage windows for construction are typically available in spring and fall of a given year. Since outages on the 500 kV lines and substations are critical for the PJM operations unless planned properly they would create outage constraints. Missing an outage window will cause a delay of at least 6 months. Therefore PPL EU activities should start soon to meet the developer’s required in service date.

Notes on the project schedule

- If proceeding further, PPL EU recommends that an interim ISA/CSA be completed during the Facilities Study stage or earlier to address the critical path items, such as the long lead purchases and the compressed project schedule.
- Procurement lead time for the 500 kV circuit breakers is 9-12 months after the order is placed.

- Excepting any operational, governmental and/or environmental regulatory delays, the use of additional resources, such as overtime, premiums for the expedited material, and/or contractor labor, may enable PPL EU to decrease this construction period for an additional cost but must be reviewed with PPL EU beforehand.
- It is also assumed that all R/W, easements, and permits are secured without impact on the anticipated construction start dates.
- In order to avoid duplication of cost and efforts, PPL EU recommends that the Interconnection Customer obtain all environmental approvals required for the construction of their SVC and share pertinent details with PPL EU prior to the start of the PPL EU direct connection facilities construction.

PA PUC Certification & Environmental Issues

Cost of the required PA PUC Certification is included in the cost estimates. It is assumed that the following will be coordinated:

- Interconnection Customer shall make available all or any R/W they own or can procure for PPL EU for the construction of the 500 kV tap to their facilities.
- PA PUC Certification would be required and will be obtained by PPL EU. This process typically takes about 6-9 months for LON and longer for full siting if the taps is >2 miles long. PPL EU will discuss environmental impacts and mitigation strategies of the facilities being certified, i.e. the 500 kV transmission tap(s).

Estimate assumptions for the direct connection

- The feasibility study does not include cost or time required to obtain, property rights, permits, R/W for the required facilities. The project developer would be responsible for the R/W, real estates, and construction permits.
- If 3 breaker ring bus is constructed by PPL EU, the cost does not include land, site preparation and grading.
- This magnitude estimate has been prepared without extensive research and field review.
- It is assumed that the all new 500 kV tap R/W would be available in a timely fashion.
- No environmental, real estate, or permitting issues were reviewed in preparing direct connection estimates.

Voltage impact of this SVC on the electric system:

Due to the large effect to voltage in the area of this project, this project was reviewed for voltage rise or drop to the 500 kV transmission systems when it is fully in service or out of service. The following observations were made based on the 2013 PJM base line case:

- 1) When the SVC is out of service there is no effect to the 500 kV transmission voltages, since the existing Cap Banks at Juniata, Alburdis, and Susquehanna 500 kV buses (and some 230 kV cap banks) are adequate to maintain required voltages. PJM has not identified any new base line reactive requirements in this area.
- 2) When the SVC is in-service at maximum MVARs, sufficient voltage rise will take place to displace the existing cap banks at the Juniata, Alburdis or Susquehanna 500 kV buses.

Network Impacts

Queue V3-023 was evaluated for compliance with reliability criteria as a 500 MVAR SVC (Static Var Control) for both interconnection options; at Hosensack 500 kV substation or on PPL's portion of the Alburdis – Branchburg 500 kV line. The results are summarized below.

NETWORK IMPACTS

Single Contingency

(Normal System, Single or N-1 contingencies)

No problems identified

Multiple Facility Contingencies

(Double Circuit Tower Line contingencies, Stuck Breaker and Bus Fault contingencies)

No problems identified.

Contribution to Previously Identified Overloads

(This project contributes greater than the PJM cost allocation threshold loading to the following contingency overloads, i.e. "Network Impacts", identified for earlier generation or transmission interconnection projects in the PJM Queue)

No problems identified.

Short Circuit

No problems identified.

System Transient Voltage and Harmonic Analysis

Harmonic Analysis will be performed for the project during the Facilities Study or earlier if the Facilities Study is skipped. In lieu of a Facilities Study, Queue V3-023 can enter into an Interim ISA (Interconnection Service Agreement) with PPL EU and PJM to advance development of detailed design specifications (may require outside engineering services), purchase long lead time equipment and advance construction.

NETWORK UPGRADE REQUIREMENTS

New System Reinforcements

(Upgrades required to mitigate reliability criteria violations, i.e. “Network Impacts”, initially caused by the addition of this project)

To be determined from System Transient Voltage and Harmonics studies.

Contribution to Previously Identified System Reinforcements

(Overloads initially caused by prior Queue positions with additional contribution to overloading by this project. This project may have a % allocation cost responsibility which will be calculated and reported for the Impact Study)

None required.