

***PJM Generator Interconnection
V3-041 Daleville 2MWe / 4MWc
Feasibility Study***

January 2010
DMS # 570923

General

Queue V3-041 (Daleville) is a SECCRA (Southeastern Chester County Refuse Authority) request to interconnect a new 2 MW landfill gas generator and to obtain CIRs (Capacity Interconnection Rights) for the new 2 MW generator plus an additional 2 MW for two previously interconnected generating units (earlier Queue N26). The total MFO (Maximum Facility Output) will be 4 MW. The new generation will be located at the same site as the existing generation which is in the vicinity of 219 Street Road, London Grove Township, Chester County, Pennsylvania. SECCRA's planned in-service date for Queue V3-041 generation is March 2010.

Direct Connection Requirements

Queue V3-041 will be connected to Daleville 34.5 kV circuit 341 as shown on the single line diagram below.

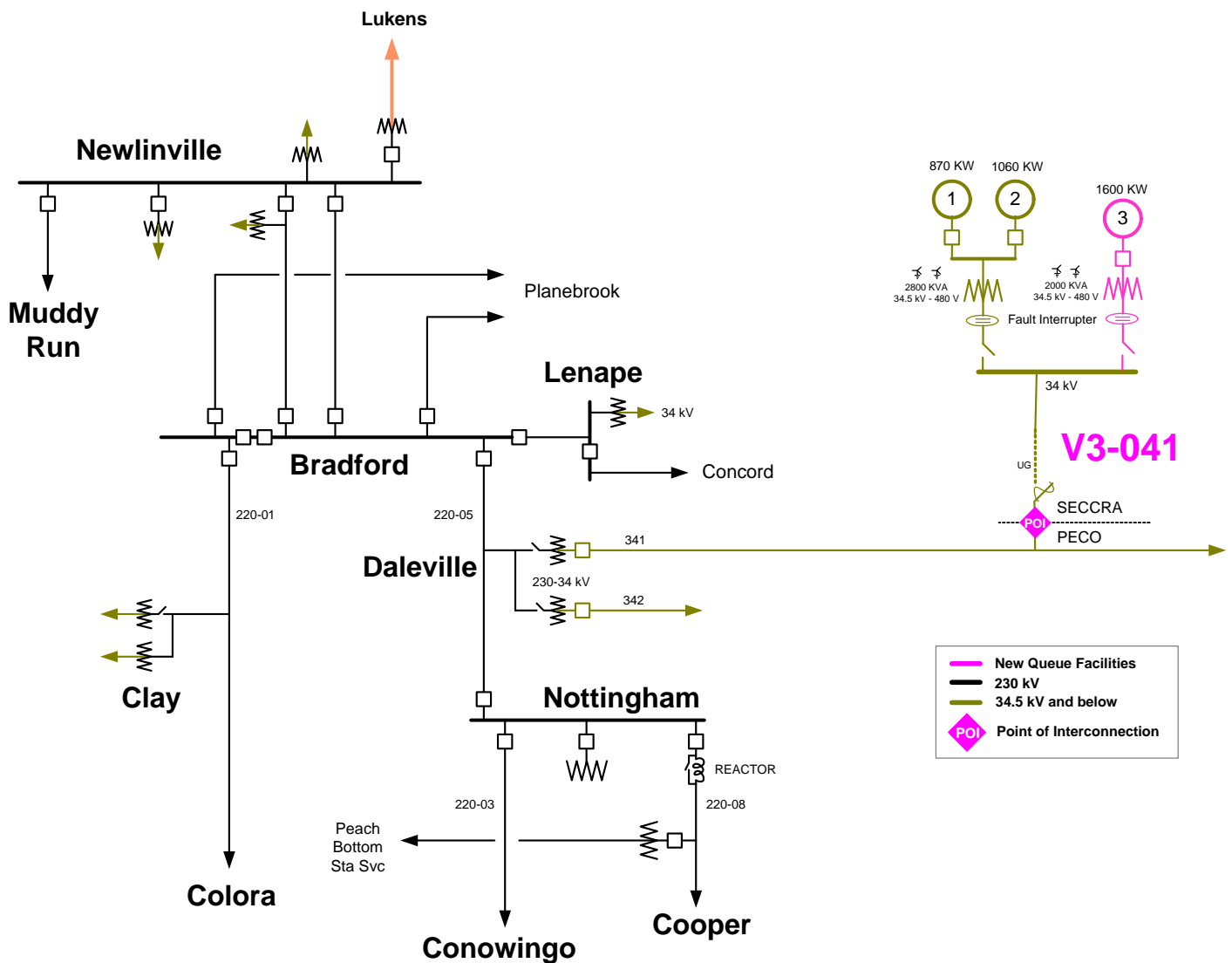

Interconnection Customer (SECCRA) Scope of Direct Connection Work

SECCRA is responsible for construction of all facilities on its side of the POI (Point of Interconnection) shown on the one line diagram of the previous page (page 2).

Metering / telemetering

PECO does not require instantaneous (real time) telemetering for generation less than 5 MW. PJM requires instantaneous (real time) KW and KVAR data for generation that is a Capacity Resource. PJM also requires Interval Revenue Metering (Hourly KW & KVAR) provided daily. See the PJM Open Access Transmission Tariff and the PJM Manuals M-01 and M-14D available at <http://www.pjm.com>

For additional PJM metering / telemetering information contact Ryan Nice at 610-666-4777 or nicer@pjm.com

Interconnection Customer may be responsible for the installation of DTT (Direct Transfer Trip) equipment at the Customer site. See Transmission Owner scope of Work below for additional details.

Transmission Owner (PECO Energy) Scope of Direct Connection Work

The addition of 2 MW for Queue V3-041 (4 MW total at Interconnection Customer site) may require the installation of DTT (Direct Transfer Trip) equipment at PECO's Daleville substation and the Interconnection Customer site to prevent the isolation of Interconnection Customer's generation to PECO load on Daleville #341 line in the event that #341 line breaker opens at Daleville Substation. PJM and IEEE 1547 standards require that the customer generation should be no more than 50 % of the isolated load. See PJM Manual 14A Attachment E – "Small Generator (10 MW and Below) Applicable Technical Requirements and Standards" page 65, paragraph 12 which can be obtained at link <http://www.pjm.com/documents/manuals.aspx>

PECO has not yet made the determination that DTT is required. This will be determined for the V3-041 Impact Study. If required, PECO will need to specify DTT and other control equipment to be used, the breaker at the customer site to be tripped and the communication medium to be used.

No other Direct Connection upgrades are required to accommodate the additional 2 MW.

Network Impacts

The system, as planned, was evaluated for compliance with reliability criteria. The V3-041 project was studied as an additional 2 MW energy addition and 4 MW Capacity interconnection to Daleville 34.5 kV circuit 341. The results are summarized below.

NETWORK IMPACTS

Normal System

No problems identified.

Single Contingency

No problems identified.

Short Circuit Analysis

No problems identified.

Contribution to previously identified Impacts

No problems identified.

Stability Analysis

Not required because of size and voltage level of generation.

NETWORK UPGRADE REQUIREMENTS

New System Reinforcements

None required.

Contribution to Previously Identified System Reinforcements

None required.