

***PJM Generator Interconnection Request
Queue #V3-058 & V3-059
Brunswick (Edgeboro) 26.4kV
Feasibility/Impact Study Report***

**January 2010
#577146**

V3-058 & V3-059 Brunswick (Edgeboro) 26.4kV Feasibility/Impact Study

General

Essex Partnership, L.L.C. has proposed installing two 2 MW solar projects at the Edgeboro Landfill, located approximately ½ mile northeast of the intersection of Edgeboro Road and Connerty Place in East Brunswick, Middlesex County, New Jersey.

The first project, Edgeboro #1, is scheduled to be in-service by June 1, 2010. The second project, Edgeboro #2, is scheduled to be in-service by October 1, 2010.

Direct Connection

The project will be connected to the existing 26.4 kV substation on the Edgeboro Landfill site. Essex Partnership is to get an agreement with owner of the substation to connect the two solar projects.

PSE&G will not require the performance of any work to establish the interconnection to these projects, since a 26.4-kV supply already exists from Brunswick (230-kV) Switching Station to Edgeboro Landfill which is adequate for this interconnection.

The output of the two solar projects will need to be individually metered.

V3-058 Brunswick (Edgeboro) 26.4kV

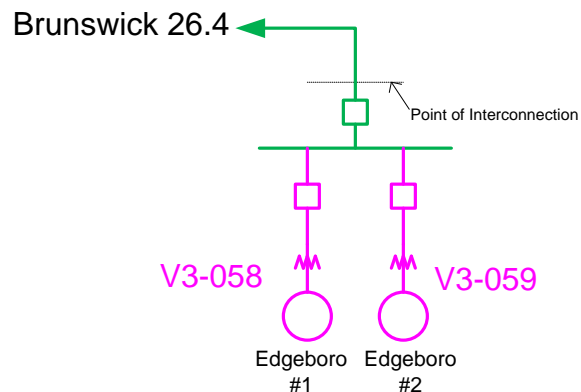

Network Impacts

The queue V3-058 and V3-059 projects were studied as 2.0MW energy injections into PSEG's system at the Brunswick 230kV substation. The project was studied on a combined feasibility-impact basis which utilizes an AC analysis, and incorporates all contingency types. Projects V3-058 and V3-059 were evaluated for compliance with reliability criteria for summer peak conditions in 2014. Potential network impacts were as follows:

Generator Deliverability

(Single or N-1 contingencies for the Capacity portion only of the interconnection)

No problems identified

Multiple Facility Contingency

(Double Circuit Tower Line, Line with Failed Breaker and Bus Fault contingencies for the full energy output)

No problems identified

Short Circuit

(Summary form of Cost allocation for breakers will be inserted here if any)

No problems identified

Stability

Not required because the project is under 30 MW.

System Reinforcements

None.

Cost Allocation

There is no anticipated cost in connecting projects V3-058 and V3-059.