

***PJM Generation Interconnection  
Queue V3-060  
Antioch 34kV  
Feasibility/ System Impact Study***

576931v1  
January 2010

## **Preface**

The intent of this System Impact Study is to determine a plan, with cost and construction time estimates, to connect the subject generation to the PJM network at a location specified by the Interconnection Customer. The Interconnection Customer may request the interconnection of generation as a capacity resource or as an energy-only resource. As a requirement for interconnection, the Interconnection Customer may be responsible for the cost of constructing: (1) Direct Connections, which are new facilities and/or facilities upgrades needed to connect the generator to the PJM network, and (2) Network Upgrades, which are facility additions, or upgrades to existing facilities, that are needed to maintain the reliability of the PJM system.

The PJM Reliability Planning Process utilizes PJM planning criteria, NERC Planning Standards, NERC Regional Council planning criteria, and the individual Transmission Owner FERC filed planning criteria. In all cases, PJM applies the most conservative of all applicable planning criteria when identifying reliability problems and determining the need for system upgrades on the PJM system. The application of the NERC Planning Standards is adapted to the specific needs of the PJM system.

In some instances an interconnection customer may not be responsible for 100% of the identified network upgrade cost because other transmission network uses, e.g. another generation interconnection or merchant transmission upgrade, may also contribute to the need for the same network reinforcement. All facilities required for interconnection of a generation interconnection project must be designed in compliance with the technical specifications (on PJM web site) for the appropriate Transmission Owner.

After the System Impact Study Agreement is executed and prior to execution of the Interconnection Service Agreement, an Interconnection Customer may modify its project to reduce the electrical output (MW) (in the case of a Generation Interconnection Request) of the proposed project by up to the larger of 20 percent of the capability considered in the System Impact Study or 50 MW.

The System Impact Study estimates do not include the feasibility, cost, or time required to obtain property rights and permits for construction of the required facilities. The project developer is responsible for the right of way, real estate, and construction permit issues. For properties currently owned by Transmission Owners, the costs may be included in the study.

## General

The queue V3-060 project is proposing a wind farm facility consisting of 13 GE 1.5MW wind turbines and has requested to be studied at 20MW injection (2.6MW Capacity) into ComEd's system at the Waukegan 138kV substation. The proposed in-service date is September 30, 2011.

## Attachment Facilities

The proposed generation project will interconnect via the 34kV network in Antioch, Illinois (See **Figure 1** below).

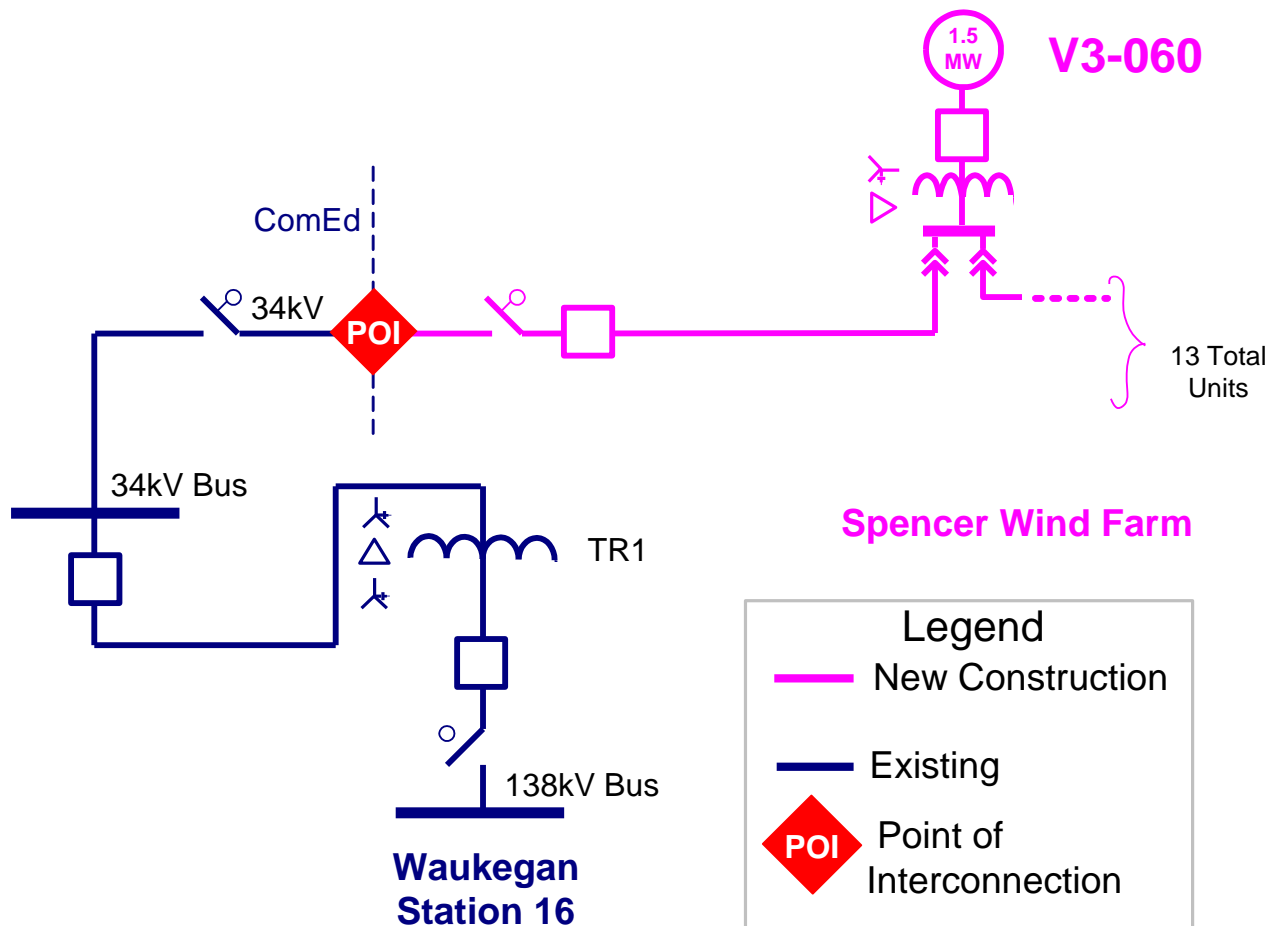

**Figure 1. Proposed Interconnection Single Line Diagram**

## Revenue Metering and SCADA Requirements

**For PJM:** IC will be required to install equipment necessary to provide Revenue Metering (KWH, KVARH) and real time data (KW, KVAR) for IC's generating Resource. See PJM Manuals M-01 and M-14D, and PJM Tariff Sections 24.1 and 24.2.

**For ComEd:** IC will be required to install equipment necessary to provide bi-directional Revenue Metering (KWH, KVARH) and real time data (KW, KVAR, circuit breaker status, and 138 kV voltage) for IC's generating Resource. See ComEd Applicable Standards available on the PJM website ("TO Standards") – "Exelon Energy Delivery Interconnection Guidelines (Generators Greater than 2MVA and Less Than or Equal to 20 MVA)".

### **Direct Connection Cost Estimate**

All cost estimates associated with the customer connecting to ComEd's system will be addressed in the IA between the customer and ComEd.

### **Network Impacts**

The queue V3-060 project was studied as a 20MW injection (2.6MW Capacity) into ComEd's system at the Waukegan 138kV substation. The project was studied on a combined feasibility-impact basis which utilizes an AC analysis, and incorporates all contingency types. Project V3-060 was evaluated for compliance with reliability criteria for summer peak conditions in 2014. Potential network impacts were as follows:

#### **Generator Deliverability**

*(Single or N-1 contingencies for the Capacity portion only of the interconnection)*

No problems identified.

#### **Multiple Facility Contingency**

*(Double Circuit Tower Line, Stuck breaker and Bus Fault contingencies for the full energy output)*

No problems identified.

#### **Contribution to Previously Identified Overloads**

*(This project contributes to the following contingency overloads, i.e. "Network Impacts", identified for earlier generation or transmission interconnection projects in the PJM Queue)*

No problems identified.

#### **New System Reinforcements**

*(Upgrades required to mitigate reliability criteria violations, i.e. "Network Impacts", initially caused by the addition of this project generation)*

None.

**Contribution to Previously Identified System Reinforcements**

*(Overloads initially caused by prior Queue positions with additional contribution to overloading by this project.)*

None.

**Short Circuit**

Not required.

**Potential Congestion due to Local Energy Deliverability**

*(PJM also studied the delivery of the energy portion of the surrounding generation. Any potential problems identified below are likely to result in operational restrictions to the project under study. The developer can proceed with Network Upgrades to eliminate the operational restriction at their discretion by submitting a Transmission Interconnection Request. Note: Only the most severely overloaded conditions are listed below. There is no guarantee of full deliverability for this project by fixing only the conditions listed in this section. With a Transmission Interconnection Request, a subsequent analysis will be performed which analyzes all overload conditions associated with the identified overloaded element(s). As a result of the aggregate energy resources in the area, the following violations were identified:*

No problems identified.