

***PJM Generator Interconnection Request
Queue #V3-067
Norfolk St. 4kV
Feasibility/Impact Study Report***

**January 2010
#576954**

V3-067 Norfolk St. 4kV Feasibility/Impact Study

General

Public Service Electric and Gas Company has proposed installing a 0.773 MW solar project on the roof of Central High School in Newark, Essex County, New Jersey. The in-service date for the project is March 31, 2010.

Direct Connection

The project will be connected to the Norfolk St. 4kV 4003 distribution feeder. PSE&G will provide the 4kV to 480 volt transformer. The point of interconnection will be at 480 volts. PSE&G will also provide the revenue metering and telemetering. Public Service Electric and Gas Company will be responsible for meeting all provisions of the project Interconnection Agreement between Public Service and PSE&G.

The cost in the Interconnection Agreement is exclusive of work required to be performed by the developer as specified in PSE&G's Information & Requirements for Electric Service Handbook. This work includes, but may not be limited to, the following:

- Developer is responsible for purchase and installation of all low voltage (277/480v) or high voltage (13-kV) service equipment as required for each site
- Developer will adhere to specifications detailed in the PSE&G Information and Requirements for electric service handbook
- Developer is responsible for all trenching and the installation of conduits and manholes as normally required and specified by PSE&G
- Developer must obtain all permits and easements required to install the interconnection facilities
- Developer must provide access for the installation, maintenance and operation of all service equipment

It is anticipated that material procurement and construction will require 6 months from the date of project approval and authorization.

Figure #1

PSE&G

Solar Production Sites – 4 or 13 kV POI

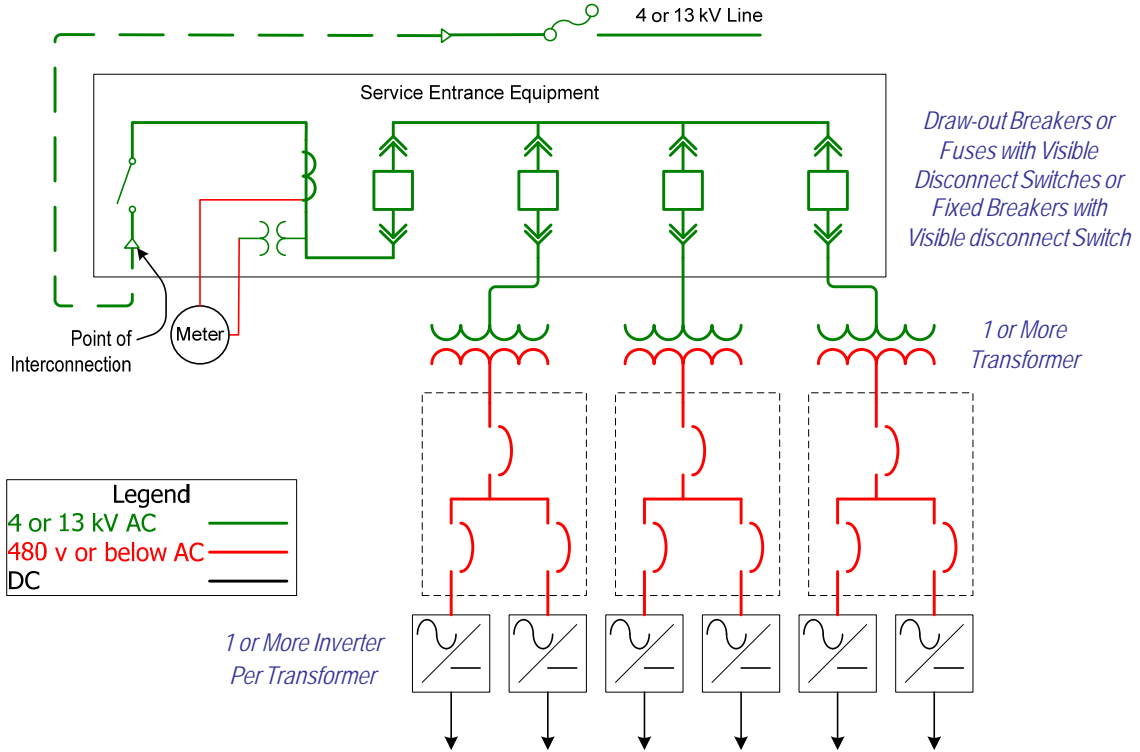

PSE&G

Solar Production Sites – 480 volt POI

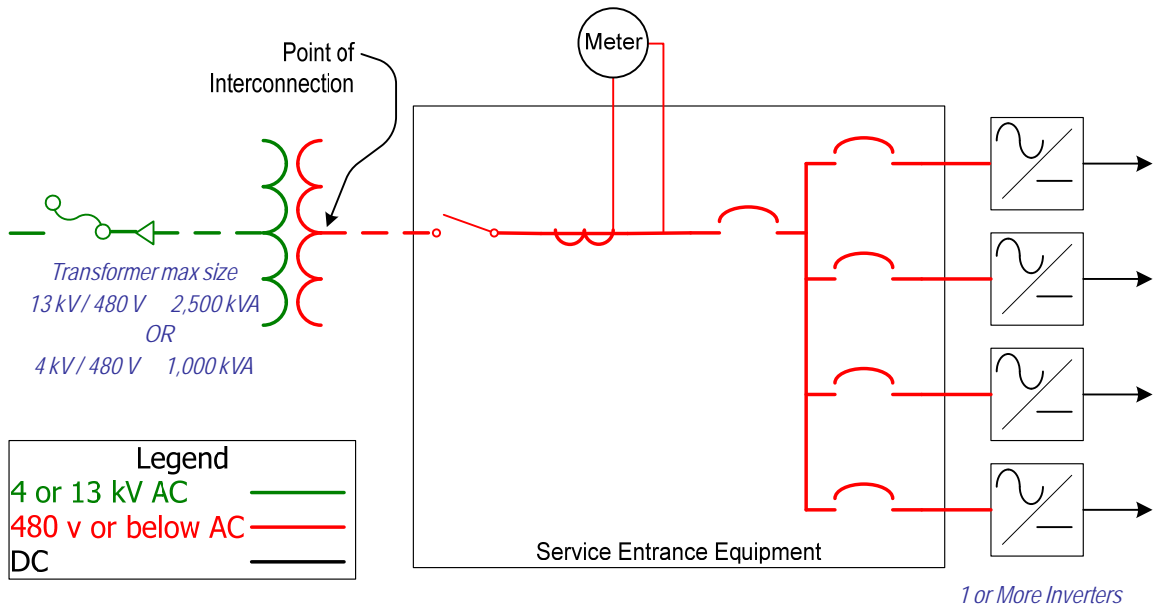

Network Impacts

The queue V3-067 project was studied as a 0.773MW injection (0.29MW of which was capacity) into PSEG's system at the Newark Switch 138kV substation. The project was studied on a combined feasibility-impact basis which utilizes an AC analysis, and incorporates all contingency types. Project V3-067 was evaluated for compliance with reliability criteria for summer peak conditions in 2014. Potential network impacts were as follows:

Generator Deliverability

(Single or N-1 contingencies for the Capacity portion only of the interconnection)

No problems identified

Multiple Facility Contingency

(Double Circuit Tower Line, Line with Failed Breaker and Bus Fault contingencies for the full energy output)

No problems identified

Short Circuit

(Summary form of Cost allocation for breakers will be inserted here if any)

No problems identified

Stability

Not required because the project is less than 30 MW.

System Reinforcements

None.