

***PJM Generator Interconnection  
V4-012 Morgantown 4.8 MW  
Feasibility / Impact Study***

***March 2010  
Docs # 582457***

## General

Queue V4-012 is a Granger Energy of Morgantown, LLC request to interconnect a 4.8 MW (Capacity) generating resource consisting of three 1.6 MW landfill gas methane generators to be located at Conestoga Landfill in Caernarvon Township, near Morgantown, Pennsylvania. Morgantown 69-12 kV substation is the closest substation to the generation, which is located near grid 51304s31213. V4-012 has requested an in-service date of December 1, 2010. **This study does not imply a PPL EU commitment to this in-service date.**

This study assumes that the proposed generation will only be allowed to operate when the distribution system is in a normal operating arrangement. Queue V4-012 has not requested an alternative outlet for the generation.

## Direct Connection

Queue V4-012 can interconnect to the existing Morgantown #32-1 12 kV line as shown on the one line diagram below.

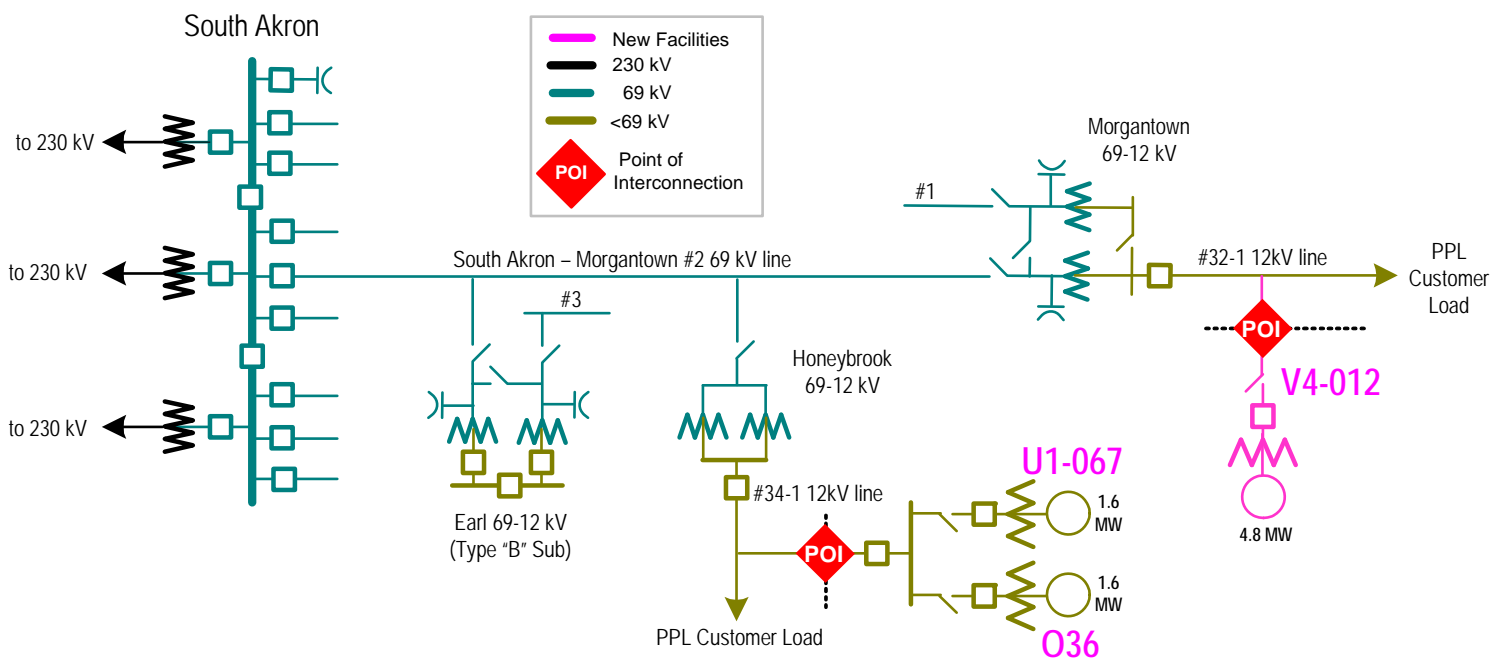

## **Interconnection Customer Scope of Direct Connection Work**

Queue V4-012 Interconnection Customer will be responsible for the construction of all generating station facilities on the V4-012 side of the POI (Point of Interconnection) as shown on the one line diagram of the previous page (page 2).

### **Protection equipment --**

The Interconnection Customer will need to install suitable protection and control equipment based on PPL EU parallel generation requirements. This includes both Intertie Protective Relaying (IPR) and Point of Contact (POC) relaying. Please refer to the PPL EU web site for the IPR and POC requirements. The website addresses are shown below:

IPR Requirements:

<http://www.pplelectric.com/Business+Partners/Tools+and+Reference+Center/Customer-Owned+Generation/>

PPL EU's preference for IPR is the Beckwith M-3520 relay package. Note that failure of the single microprocessor-based relay will disable the protection. For that reason PPL EU requests that a backup relay be installed. The alternative would be to disconnect the generation in the event that the single relay is out of service. Suitable choices for backup are the ABB DPU 2000R or SEL 351 packages.

POC Requirements:

[http://www.pplelectric.com/NR/rdonlyres/B0937C7E-B6E9-40AD-AE8C-ED3C9558E528/0/point\\_of\\_contact.pdf](http://www.pplelectric.com/NR/rdonlyres/B0937C7E-B6E9-40AD-AE8C-ED3C9558E528/0/point_of_contact.pdf)

### **DTT Relaying Requirements--**

Direct Transfer Trip (DTT) protection will be required for the proposed Queue V4-012 interconnection. Queue V4-012 generation will be tripped from the Morgantown 69-12 kV substation for opening of the 32-1 12 kV line breaker.

Queue V4-012 Interconnection Customer will be required to install telephone line based Direct Transfer Trip equipment (matching PPL Electric Utilities equipment) to the PPL EU Morgantown Substation.

Suitable protection for the above phone lines is based on IEEE 487-2000.

### **SCADA Requirements--**

PPL EU will require the installation of a PPL EU approved SCADA equipment that will connect to its existing SCADA system. PPL Electric Utilities will supply suitable drawings and a material list for the generator to provide this equipment. The current PPL Electric Utilities design uses commercially available PLC equipment, with the software provided by PPL Electric Utilities.

### **Metering Equipment Installation at the Point of Interconnection--**

Installation of revenue grade Metering Equipment will be required at the Queue V4-012 Point of Interconnection (POI). PPL EU will design and supply the required metering equipment, however, the installation, the secondary wiring connections and the associated costs are the responsibility of the developer. All metering equipment must meet applicable PPL EU tariff requirements as well as any applicable requirements of the PJM agreements. The equipment should be housed in a suitable metering cabinet or similar enclosure and must be accessible to PPL EU metering personnel.

### **Isolation Breaker Requirement --**

V4-012 Interconnection Customer will have its own isolation breaker. This breaker can be located on either the high or low side of the Interconnection Customer's transformer. It will be operated by the IPR relaying, DTT and, if located on the high side, the POC relaying. This device will NOT be used to synchronize or parallel operating generation to the PPL EU system.

### **Transformer Requirement--**

V4-012 Interconnection Customer's high side transformer WYE windings should have impedance grounding because of functioning as a system grounding bank. The Customer will need to confirm that the transformer will have fully insulated windings suitable for impedance grounding.

See page 25, section 1.7 of the "Relay and Control Requirements For parallel Operation of Generation" rev 13 as posted on the PJM and PPL web site for additional information.

### **Transmission Owner (PPL EU) Scope of Direct Connection Work**

Queue V4-012 can be interconnected to the existing Morgantown 32-1 12 kV line which is served from Morgantown 69-12 kV transformer #2. The following requirements were determined with consideration of the existing U1-067 and O36 total 3.2 MW generation at Granger Energy of Honey Brook, interconnected to the Honey Brook 34-1 12 kV line. Morgantown 69-12kV transformer #2 and Honey Brook Substation are both supplied from the South Akron – Morgantown #2 69 kV line. Refer to the one line diagram above.

To accommodate the interconnection of V4-012, substation work at one PPL EU-owned regional substation (South Akron) and three PPL EU-owned area supply substations (Morgantown, Honey Brook, and Earl) is required. **The total estimated cost is \$381,000.** This estimate assumes that the generation will be operated at a leading 0.95 power factor as described later in the study.

The following relay and control upgrades at PPL EU facilities will be required in order to accommodate the generation interconnection with the proposed DTT communication scheme:

### **Regional Transmission Substation Work (\$10,000)**

At the regional South Akron 230/138/69kV substation, install synchro-check relaying on the South Akron – Morgantown #2 69 kV line circuit breaker. The South Akron relay protection controls were designed assuming that the South Akron – Morgantown #2 69 kV line remains in radial operation. The introduction of this additional generation, in conjunction with the existing Honey Brook U1-067 and O36 generation, invalidates this design. Synchro-check relaying on the South Akron 69 kV line breaker is required to ensure no out-of-synchronism reclosure can occur.

## **Distribution Work (\$371,000)**

The \$371,000 cost estimate includes relay and control modifications at Morgantown, Honey Brook, and Earl area supply substations.

### Morgantown 69-12 kV substation (\$266,000)

At Morgantown 69-12 kV Substation, install an anti-islanding protection scheme. This is required to detect a local island condition for loss of the 69 kV source to Morgantown Substation. The 12 kV CB 32-1 (Bay 5) at Morgantown will be modified to have the existing electro-mechanical relays replaced with a modern microprocessor based relay. This will provide anti-islanding functionality for loss of the 69 kV source.

Direct Transfer Trip (DTT) protection will be required from Morgantown 69-12 kV Substation for V4-012 generation. **The communication technology to accommodate this DTT scheme has not been decided yet but will need to be determined as soon as possible following signing of the ISA agreement so that engineering may commence. This estimate provided in this study assumes that telephone based DTT is used,** however four alternatives may be possible to obtain DTT Communication Between V4-012 and Morgantown 69-12 kV Substation:

- Telephone-Based DTT: (\$266,000)
  - Telephone based DTT is the basis for this estimate. If this is the chosen alternative, V4-012 must contact the local telephone company High Voltage Protection Group to begin the engineering review and to initiate the process for establishing service at V4-012's high voltage facility. The lead time to establish phone service at high voltage sites may be 3-4 months or longer. Be aware that the DTT (PRDA type telephones lines) are NOT a tariff service, therefore you may experience difficulty in obtaining this service, and we will attempt to help when this arises.
- Radio-Based DTT, using previous analysis for Queue L03: (estimated \$ \_\_\_\_\_)
  - In 2004, analysis for since-withdrawn Queue L03, which was located in close proximity to the current V4-012 project site, had discovered a suitable antenna location for radio-based DTT. It would be feasible to use the original design and extend fiber to the location of V4-012, provided that the antenna is mounted 15-20 feet higher than it was previously, so as to avoid interference from vehicular traffic at the landfill. The cost estimate for this option would be less than that for phone-based DTT. V4-012 would be responsible for the fiber installation.
- New Radio Installation: (estimated \$ \_\_\_\_\_)
  - It is unknown if radio DTT to the new location is feasible. The developer would need to provide the exact location of a radio antenna at the new location. PPL has assumed this will probably not be a viable option based on the kickoff conference call. Again, the cost estimate for this option would be less than that for phone-based DTT.
- Fiber Optic Based DTT (estimated \$ \_\_\_\_\_)
  - The costs associated with installing fiber from Morgantown substation to the developer have not been included. PPL is assuming that IPP V4-012 will operate at a leading

power factor as mentioned above and therefore a rebuild of the line will not be necessary. Fiber may still be the used as the DTT communication path, at the developer's request.

#### Honey Brook 69-12 kV Substation (\$25,000)

At Honey Brook 69-12 kV Substation, the existing DTT scheme at the 34-1 12kV line breaker to U1-067 and O36 (Granger Energy of Honey Brook) will need to be modified in order to accommodate the new anti-islanding protection scheme. The 12 kV CB 34-1 (Bay 2R) at Honey Brook will be modified to have the existing electro-mechanical relays replaced with a modern microprocessor based relay. This will provide anti-islanding functionality for loss of the 69 kV source.

#### Earl 69-12 kV substation (\$65,000)

At Earl 69-12 kV Substation, install synchro-check relaying on the low-side circuit breakers of both transformers. Earl Substation is designed with protection controls that assume the transmission sources will always be in phase and synchronized with 69 kV system. The introduction of this new independent generation, in conjunction with Honey Brook U1-067, invalidates this assumption. Facilities must be installed to verify that the 69 kV system and the proposed generation are in-phase before the low side breakers are allowed to reclose.

The work at Earl 69-12 kV substation includes:

- Modification of controls to include synchro-check relaying on the 12 kV transformer breakers,
- Synchro-check relay cabinet,
- Cables for AC and DC supplies,
- Cables for transformer breaker interlocks,
- 12 kV potential transformer, cabinet, and associated wiring.

#### **Voltage Regulation Requirements**

As required by the PJM tariff, the developer shall design its facility to maintain a composite power factor delivery at continuous rated power output at the point of interconnection at a power factor of at least 0.95 leading (absorbing VARs) to 0.90 lagging (supplying VARs). In order to maintain acceptable voltage regulation on the 12kV system served from Morgantown substation, studies indicate that **the facility must operate with a 0.95 leading power factor (absorbing Vars) at the point of interconnection (MW out; MVAR in)**. With the intertie transformer consuming a significant amount of reactive power, the 0.95 leading power factor at the point of interconnection should be within the capability of the V4-012 machines. **If the developer determines that the proposed machines can not operate in a mode to hold 0.95 leading power factor at the point of interconnection, it will be necessary to reconductor approximately 1 mile of existing 12 kV line to new 477 kmil AL conductor or equivalent at a cost of approximately \$400,000. V4-012 developer should notify PPL EU immediately if a 0.95 leading power factor can not be achieved at the point of interconnection.**

#### **Direct Connection Timing**

In order to engineer and complete the above modifications during normal work periods, PPL will require **9 months** from the time that the PPL 2-party IA agreement is executed. Consequently, the requested in-service date may be in jeopardy. In addition, the following must be completed immediately to achieve an in service date of December 1, 2010:

Any delays in executing the PPL 2-party IA may require Queue V4-012 to accept an increased cost obligation for funding engineering and construction overtime to meet a compressed work schedule. The estimated overtime amount could be 150% of the above-identified cost.

The V4-012 Interconnection Customer must provide engineering drawings to PPL EU for final review and recommendations prior to construction.

The telephone cable and related telephone infrastructure at V4-012's high voltage site must meet modern IEEE 487 standards. For existing facilities, this may require that existing telephone circuits have the same high voltage protection installed or upgraded.

V4-012 must contact the local telephone company High Voltage Protection Group to begin the engineering review and to initiate the process for establishing service at V4-012's high voltage facility. The lead time to establish phone service at high voltage sites may be 3-4 months or longer. The developer should understand that DTT using PRDA type telephones lines are NOT a tariff service, therefore difficulty in obtaining this service may be experienced. PPL EU may be able to provide assistance should this issue arise. V4-012 should secure the required phone lines as soon as possible for the telephone based DTT protection scheme to Morgantown 69-12 kV area substation.

## ***Network Impacts***

Queue V4-012 was studied as a 4.8 MW (capacity) injection into the Morgantown #32-1 12 kV line. V4-012 was evaluated for compliance with reliability criteria for summer peak conditions in 2013. Potential network impacts were as follows:

### NETWORK IMPACTS

#### **Local System Impacts**

*(Local distribution system overloads for Normal System or contingencies caused by this queue)*

No problems identified.

#### **Generator Deliverability**

*(Overloads for Normal System, Single or N-1 contingencies caused by this queue at a MW output equal to the requested Capacity for the interconnection)*

No problems identified.

#### **Multiple Facility Contingencies**

*(Overloads for Double Circuit Tower Line, Stuck Breaker and Bus Fault contingencies caused by this queue at full energy output)*

No problems identified.

#### **Contribution to Overloads Subject to Cost Allocation**

*(This project contributes greater than the PJM cost allocation threshold amount of loading to the following contingency overloads, i.e. "Network Impacts" which were identified for other relative Queues subject to cost allocation.)*

None identified.

#### **Short Circuit**

No problems identified.

#### **Stability Analysis**

Not required because of generator size and Point of Interconnection.

## NETWORK UPGRADE REQUIREMENTS

### **New System Reinforcements**

*(Upgrades required to mitigate reliability criteria violations, i.e. “Network Impacts”, initially caused by the addition of this project generation)*

None required.

### **Contribution to Previously Identified System Reinforcements**

*(Overloads initially caused by other Queue positions with contribution to the overloading by this project. This project will have a % allocation cost responsibility)*

None.

### **Short Circuit Upgrades**

None.