

***PJM Generator Interconnection
V4-075 Warwick 2 MW
Feasibility / Impact Study***

April 2010
Docs #590116

General

Queue V4-075 is a Sustainable Energy Holdings, LLC request to interconnect a 2 MW (0.76 MW Capacity) generation resource consisting of a ground array of photovoltaic panels. The new generation will be located near 600 Creekside Lane, Lancaster County, Lititz Pennsylvania. Queue V4-075 has requested an October 1, 2010 in-service date. **This study does not imply a PPL EU commitment to this in-service date.**

Direct Connection

Queue V4-075 generation can be connected to the Warwick 12 kV line #76-1 as shown on the single line diagrams below and Attachment 1.

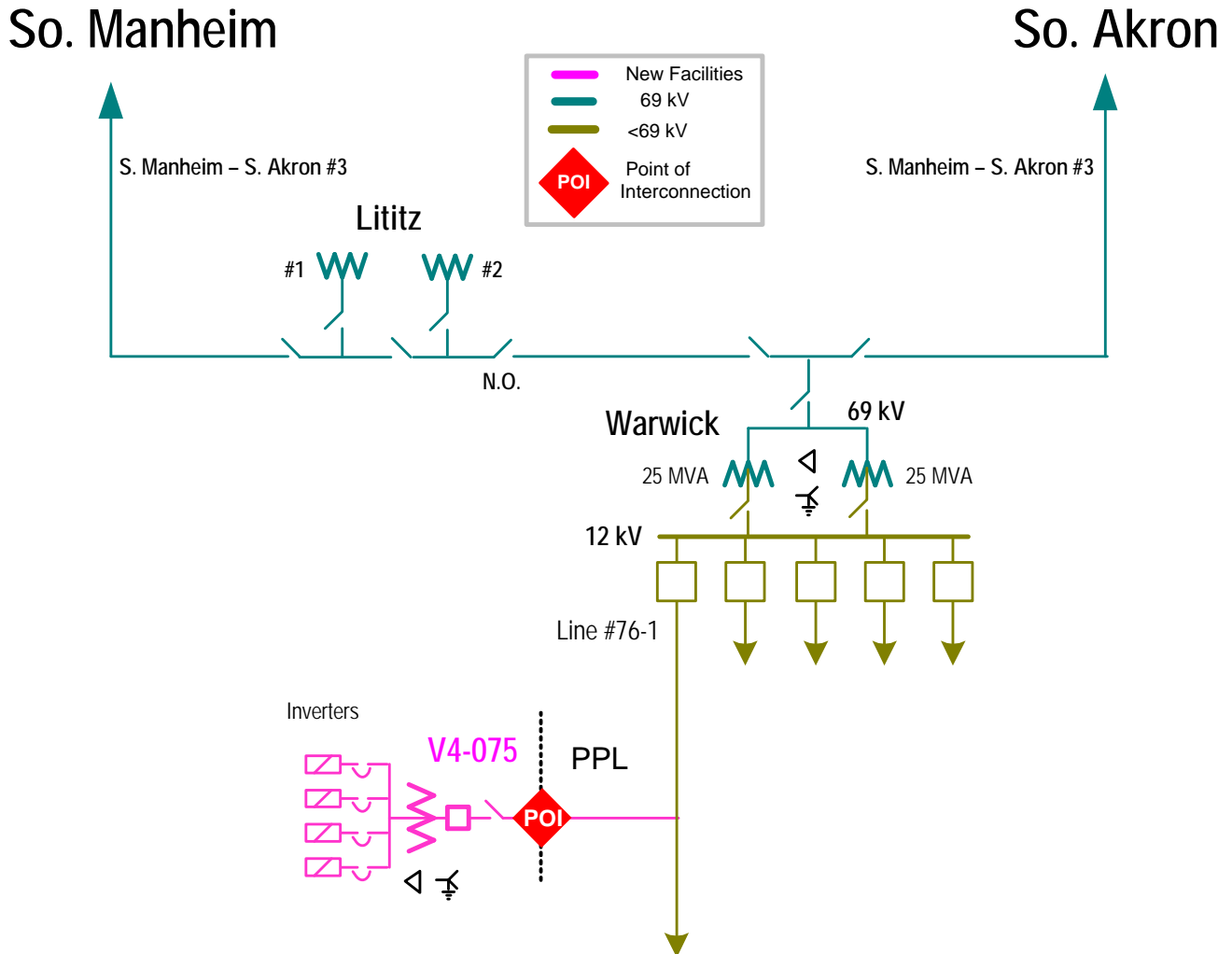

The total estimated cost for PPL EU to construct the Queue V4-075 Direct Connection facilities is **\$271,000.00** and the estimated construction time is **9 months**.

V4-075 Interconnection Customer (Sustainable Energy Holdings, LLC)

Scope of Work

Queue V4-075 Interconnection Customer is responsible for design, construction and costs for all facilities associated with V4-075 on the Interconnection Customer side of the POI (Point of Interconnection) shown on the single line diagram of the previous page.

Protection Equipment:

The Interconnection Customer is required to install suitable protection and control equipment based on PPL EU's Applicable Standards for interconnection of parallel generation. This includes both Intertie Protective Relaying (IPR) and Point of Contact (POC) relaying. The PPL EU web site links for the IPR and POC requirements are shown below. NOTE: the preferred IPR relay is the Beckwith M3520.

IPR Requirements:

<http://www.pplelectric.com/Business+Partners/Tools+and+Reference+Center/Customer-Owned+Generation/>

POC Requirements:

http://www.pplelectric.com/NR/rdonlyres/B0937C7E-B6E9-40AD-AE8C-ED3C9558E528/0/point_of_contact_r1.pdf

Direct Transfer Trip

PPL EU has reviewed the requirement for Direct Transfer Trip (DTT) on this installation. Normally DTT is required if there are other PPL EU customers involved that could be islanded with the generation. Normally with other customers on the line, inverter-based installations are required to have anti-islanding capability built in as part of the IEEE 1547 and UL 1741 requirements. This capability is to be certified and tested by an OSHA listed Nationally Recognized Testing Laboratory (NRTL). The inverters **HAVE NOT BEEN IDENTIFIED**. Therefore, PPL EU would require DTT in this instance unless proof is provided as listed in the following:

All inverters to be used for connecting generation to the PPL EU system are required to be certified to UL1741 and IEEE 1547. The term certified is understood to indicate a NRTL has tested the device to the appropriate standard, in this case UL1741 and IEEE 1547. Any inverter not meeting the NRTL certification either will not be allowed to connect to the PPL EU system, or will be required to install suitable external protection equipment to provide the same level of protection. Further, the inverter vendor must provide upon

request copies of the certification of the inverter equipment from the NRTL. Self certification or certification by a third party that is not listed on the OSHA web site will not be accepted.

OSHA's website may be referenced for a listing of NRTL logos and qualifications:

http://www.osha.gov/dts/otpca/nrtl/faq_nrtl.html

PPL EU would be willing to eliminate the need for DTT **IF** the inverters utilized in this installation were certified by an OSHA certified NRTL.

If the need arises to transfer V4-075 to an alternate source, for maintenance, restoration of service, or any other reason, V4-075 will be required to isolate from PPL's system temporarily. This is required since only the Warwick line #76-1 12 kV circuit breaker is being modified to accept V4-075 generation.

SCADA Requirements:

None

Metering and Telemetering Requirements for PJM:

The Interconnection Customer will be required to install the equipment necessary to provide revenue metering (KWH and KVARH hourly data sent once per day) and real time data (telemetry) for the Interconnection Customer's generating resource in compliance with PJM Manuals M-01 and M-14B, and the PJM Tariff. **Real time data (telemetry) is only required if Queue V4-075 is a Capacity Resource.**

For additional information regarding PJM metering requirements and the PJM internet-based telemetry alternative (Arcom Director) contact Ryan Nice at 610-666-4777 or nicer@pjm.com

Metering and telemetering requirements for PPL EU:

New metering equipment is required, it will be provided by PPL EU at no cost to the Interconnection Customer (Sustainable Energy Holdings LLC).

Isolation Breaker Requirement:

V4-075 Interconnection Customer will have its own isolation breaker that is capable of separating the V4-075 generation from the PPL EU system. This breaker will be operated by the PPL EU Controlled POC and/or IPR relaying. The Interconnection Customer may also operate this breaker by its own protection and control equipment. As per PPL EU design requirements, sharing of IPR/POC equipment within the IPR cabinet with the Interconnection Customer is not allowed.

Interconnected Transmission Owner (PPL EU) Direct Connection **Scope of Work**

The following distribution modifications will be required on the Warwick #76-1, 12 kV line in order to accommodate the generation:

1. 12 kV line tap (Estimated cost = Cost To Be Determined)

Construct a 12 kV line from a tap point on #76-1 line, to the V4-075 Point of Interconnection, at Sustainable Energy Holdings LLC Interconnection Customer facility.

- V4-075 must submit a request for electric service for the service extension. V4-075 can contact PPL's ICS department at 1-888-220-9991 or:
<http://www.pplelectric.com/Commercial+and+Industrial/Service+Center/Building+or+Renovating/>
- The cost for the extension will be engineered and direct billed separate from this feasibility/impact study and is not included in the PPL scope of work.

Queue V4-075 generation will be interconnected to the PPL EU 12 kV distribution system as shown in Figures 1 and 2. No reinforcement of the 12 kV distribution system is required for Queue V4-075.

2. Voltage check capability will need to be installed on Warwick Substation circuit breaker. This includes the IPP drawing review, commissioning work at the V4-075 site, etc. Estimated cost = \$141,000
3. Modifications at Warwick substation to include installation of DTT equipment, associated wiring, cables and conduit. Cost for radio/fiber based DTT, installed in conjunction with other work at Warwick Substation is estimated to be \$100,000 to \$130,000 depending on the communication, radio or fiber.

Network Impacts

The queue V4-075 project was studied as a 2MW energy (0.76 MW Capacity) injection into PPL's Warwick 12kV #76-1 line. The project was studied as a combined Feasibility and Impact study which utilizes an AC analysis, and incorporates all contingency types. Project V4-075 was evaluated for compliance with reliability criteria for summer peak conditions in 2014. Potential network impacts were as follows:

Generator Deliverability

(Single or N-1 contingencies for the Capacity portion only of the interconnection)

No problems identified.

Multiple Facility Contingency

(Double Circuit Tower Line, Stuck breaker and Bus Fault contingencies for the full energy output)

No problems identified.

Short Circuit

No problems identified.

Contribution to Previously Identified Overloads

(This project contributes to the following contingency overloads, i.e. "Network Impacts", identified for earlier generation or transmission interconnection projects in the PJM Queue)

No problems identified.

New System Reinforcements

(Upgrades required to mitigate reliability criteria violations, i.e. "Network Impacts", initially caused by the addition of this project generation)

None required.

Contribution to Previously Identified System Reinforcements

(Overloads initially caused by prior Queue positions with additional contribution to overloading by this project. This project may have a % allocation cost responsibility which will be calculated and reported for the Impact Study)

None required.

.

ATTACHMENT #1
Interconnection One Line Diagram

V4-075 Interconnection Single Line Diagram

