

***Generation Interconnection
Feasibility Study Report
Web Version***

For

***PJM Generation Interconnection Request
Queue Position W2-011***

Conemaugh Unit 2

Feasibility Study

Conemaugh #2 (W2-011) Generation Project

Introduction

This Feasibility Study report provides the documentation of an assessment that has been performed by PJM Interconnection and FirstEnergy (FE) in response to a request made by Interconnection Customer for the net increase of 20 MW generation capacity of the existing 850 MW coal fired Conemaugh Generator Unit #2, resulting in a new maximum rating of 870 MW (870 MW Capacity) generation to the Penelec Transmission System. As per the PJM Interconnection Planning study process, the Conemaugh #2 (W2-011) Project assessment was accomplished by: 1. Evaluating the reliability impact of the proposed facilities and connection on the interconnected transmission system by the performance of a power flow study; 2. Ensuring compliance with the NERC, ReliabilityFirst, PJM and FE Reliability Standards by identifying the system reinforcements that will need to be installed for an interconnection of the proposed project; 3. Coordinating and cooperating with the PJM staff and Interconnection Customer by participating in project meetings and issuing this report as a part of the Interconnection Planning study process; 4. Performing a Steady State, Short-Circuit and Dynamics Study as necessary; 5. Conducting all studies in accordance with the PJM Manuals, the "FE Requirements for Transmission Connected Facilities", and the "FE Study Guide".

Connection Facilities

In compliance with the PJM Interconnection Planning protocol, Interconnection Customer has submitted a "Form of Generation Interconnection Feasibility Study Agreement" to PJM that identifies its plan to increase by 20 MW the maximum generation output of the existing coal fired Conemaugh Unit #2 from 850 MW to 870 MW at the Conemaugh Generating Plant located in Indiana County, PA (see Attachment 1). For purposes of this report, it has therefore been designated as the Conemaugh #2 (W2-011) 500kV Project to reflect that it is the existing Unit #2 generator in the Conemaugh Power Plant and its interconnection voltage of 500 kV. The existing direct connection of this Unit #2 generator is to remain. Therefore, there are no procurement and construction responsibilities of Interconnection Customer for direct connection of the Conemaugh #2 (W2-011) 500kV Project. A summary of the Conemaugh #2 (W2-011) 500kV Project direct connection facilities that will be required and their estimated costs are therefore not applicable.

Power Flow Analysis

A Power Flow study was conducted to determine the reliability impact of the proposed Conemaugh #2 (W2-011) 500kV Project on the FE Transmission System. This included the performance of a contingency analysis to identify any facility overload or voltage condition that violates the FE Planning Criteria. Any such violation that is either directly attributable to this project or for which it will have a shared responsibility is included in this report with a least cost plan identified to mitigate them.

The Conemaugh #2 (W2-011) 500kV Project Power Flow Analysis was performed using a 2014 summer peak load base case power flow provided by the PJM staff. Note that the companion generator, Conemaugh Unit #1, was modeled with a maximum rating of 870 MW based on the PJM project W2-010 queue order rules. This base case included a detailed representation of the Penelec transmission system in the area of the existing Conemaugh 500kV substation. A simulation of all possible contingencies within the NERC and FE Planning Standards that are impacted by the Conemaugh #2 (W2-011) 500kV Project was conducted to test for criteria compliance.

The direct connection of the Conemaugh #2 (W2-011) 500kV Project to the Penelec transmission system was studied as an additional 20 MW generation capability to the existing Unit #2 generator 22 kV bus, then stepping up to 500 kV for an interconnection to the Conemaugh 500 kV Substation (see Attachment 2).

The results from the study Power Flow Analysis showing a comparison of the FE and PJM contingency study results are detailed on Attachment 4. As shown, there are no contingencies which create a thermal overload on the Penelec transmission system. Therefore, there are no network reinforcements for the Conemaugh #2 (W2-011) 500kV Project as shown on Attachment 6, and the estimated cost of network reinforcement is zero as shown on Attachment 5.

Short Circuit and Dynamics Analysis

The Conemaugh #2 (W2-011) 500kV Project is requesting an additional 20 MW of generation capacity as a result of a “turbine upgrade”. This upgrade will not change the actual electrical characteristics of the generator, so any fault current contributions would remain the same, and no short circuit study is needed.

Note that if PJM deems it necessary, stability studies will be conducted by the PJM staff should this project proceed to the System Impact Study stage of the Interconnection Planning process.

System Protection Analysis

The Conemaugh #2 (W2-011) 500kV Project is requesting an additional 20 MW of generation capacity as a result of a “turbine upgrade”. This upgrade will not change the existing direct connection of the generator, so all system protection requirements would remain the same, and no system protection analysis is needed.

Metering

Interconnection Customer will be required to comply with all FE Revenue Metering Requirements for Generation Interconnection Customers. These FE requirements are detailed on Attachment 7 of this report.

Compliance Issues

Interconnection Customer will be responsible for meeting all FE criteria as defined in the FE Requirements for Transmission Connected Facilities document. While the voltage analysis is not performed for the feasibility study, any voltage criteria violations that would require the plant to provide reactive power, that determination of reactive power requirements will be determined in the system impact study, which will include the low voltage ride through analysis.

Interconnection Customer must also meet all PJM, ReliabilityFirst and NERC reliability criteria and operating procedures required for standards compliance. For example, the Developer will need to properly locate and report the over and under-voltage and over and under-frequency system protection elements for its units as well as the submission of the generator model and protection data required to satisfy the PJM and ReliabilityFirst audits. Failure to comply with these requirements may result in a disconnection of service if the violation is found to compromise the reliability of the FE system.

FE Facility Upgrades and Costs

The results from the FE power flow analysis (Attachment 4) show that there are no FE criteria violations that are directly attributable to the capacity of the Conemaugh #2 (W2-011) 500kV Project.

Note that the FE and PJM study results differ somewhat due to the differences in the study process and power flow programs utilized. However, the overall conclusions reached by the FE and PJM staff are the same. In accordance with the Interconnection Planning procedures defined in the PJM Open Access Transmission Tariff and PJM Manuals, Interconnection Customer is responsible for network upgrades with cost allocation determined by PJM. There are no network facility reinforcement costs as shown in Attachment 5. Since the direct connection already exists, there are no direct connection costs as shown in Attachment 3.

FE herein reserves the right to return to any issues in this document and, upon appropriate justification, request monies to complete any reinforcements to the transmission system.

Interconnection Customer Requirements

In addition to the FE facilities, Interconnection Customer will also be responsible for meeting all criteria as specified in the applicable sections of the "FE Requirements for Transmission Connected Facilities" document including:

1. The purchase and installation of the minimum required FE generation interconnection relaying and control facilities. This includes over/under voltage protection, over/under frequency protection, and zero sequence voltage protection relays.

2. The purchase and installation of a 500 kV interconnection metering instrument transformer. FE will provide the ratio and accuracy specifications based on the customer load and generation levels.
3. The purchase and installation of a revenue class meter for each unit to measure the power delivered in compliance with the FE standards.
4. The purchase and installation of supervisory control and data acquisition (SCADA) equipment to provide information in a compatible format to the FE Transmission System Control Center.
5. The establishment of dedicated communication circuits for SCADA report to the FE Transmission System Control Center.
6. A compliance with the FE and PJM generator power factor and voltage control requirements.
7. The execution of a back-up service agreement to serve the customer load supplied from the Conemaugh 500kV substation when the units are out-of-service. This assumes the intent of Interconnection Customer is to net the generation with the load.
8. Requirement deleted.

The above requirements are in addition to any metering required by PJM.

Summary

The Conemaugh #2 (W2-011) 500kV Project is a turbine upgrade for the Conemaugh Unit #2 generator and needs no direct connection upgrade. Therefore the direct connection cost is \$0.

In addition, the Conemaugh #2 (W2-011) 500kV Project requires no network reinforcements. Therefore the cost of the FE transmission system upgrades is \$0. The PJM staff will be responsible for determining the allocation of costs to the Interconnection Customer in compliance with the existing Interconnection Planning procedures.

Attachment 1
Conemaugh #2 (W2-011) Interconnection Planning Project
Project Location

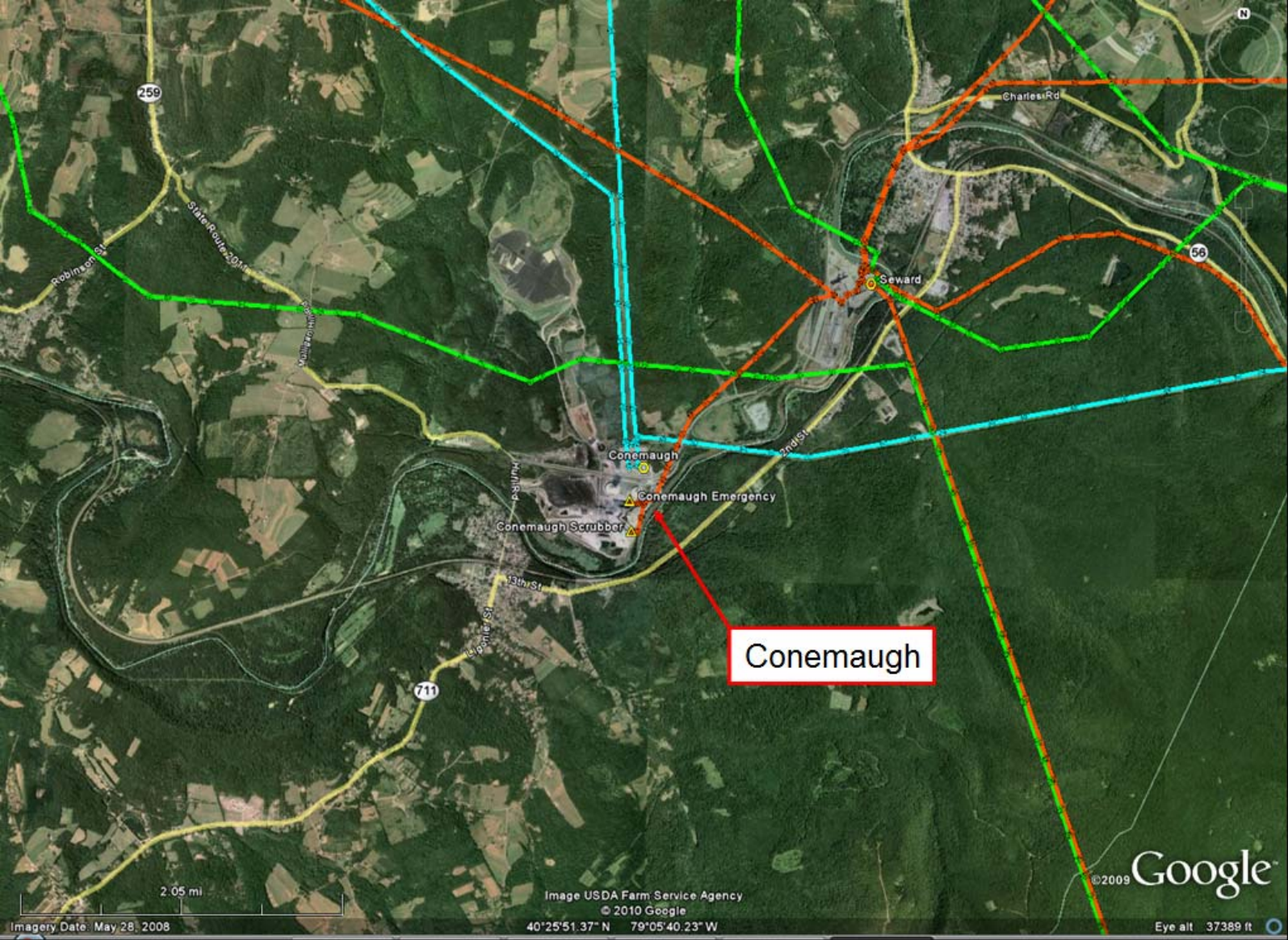

Attachment 2
Conemaugh #2 (W2-011) Interconnection Planning Project
Existing 500 kV Interconnection Substation Configuration

W2-011

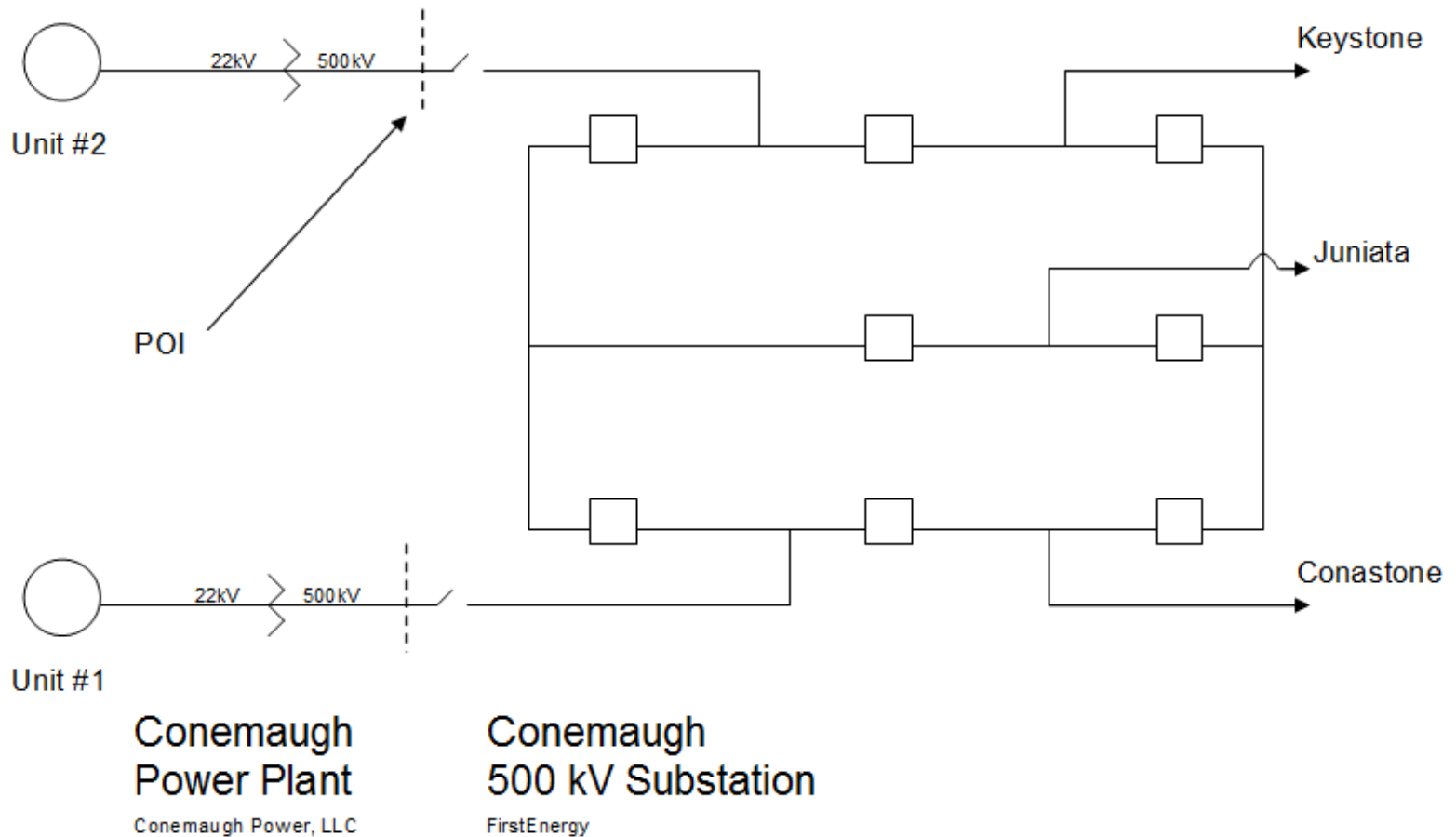

Attachment 3
Conemaugh #2 (W2-011) Interconnection Planning Project
Direct Connection Requirements

None

Attachment 4

Conemaugh Generator Unit #2 PN 500kV (W2-011) Feasibility Study

FE Contingency Analysis Results

Identified New Project Upgrades

PJM #	FE Contingency	Type	Outage Description	Overloaded Element	N/4-Hr Rating	FirstEnergy Results		PJM Results	
						MYA Flow	% Rating	MYA Flow	% Rating
				No problems					

Contributions To Previously Identified Overloads

PJM #	FE Contingency	Type	Outage Description	Overloaded Element	N/4-Hr Rating	FirstEnergy Results		PJM Results	
						MYA Flow	% Rating	MYA Flow	% Rating
				No Problems					

Potential Congestion due to Local Energy Deliverability

PJM #	FE Contingency	Type	Outage Description	Overloaded Element	N/4-Hr Rating	FirstEnergy Results		PJM Results	
						MYA Flow	% Rating	MYA Flow	% Rating
				No Problems					

Attachment 5
Conemaugh #2 (W2-011) Interconnection Planning Project
Network System Reinforcements

None

Attachment 6
Conemaugh #2 (W2-011) Interconnection Planning Project
System Reinforcements Conceptual One-line Diagrams

None

Attachment 7

FirstEnergy Revenue Metering Requirements for Generation Interconnection Customer

Interconnection Customer shall install, own, operate, test and maintain the necessary revenue quality Metering Equipment. This includes current transformers, voltage transformers, mounting structures, wiring, meters, communication circuits, and associated devices. The Metering Equipment must meet the specifications listed in the FirstEnergy and regional transmission organization (RTO) connection documents. The FirstEnergy "Requirements for Transmission Connected Facilities" are located at: <http://www.firstenergycorp.com/feconnect>

The Metering Equipment shall be located at the generation facility on the high voltage side of the generator step-up transformers or facility main step-up transformer and/or station service power transformers. Power flows to and from the facility shall be compensated to the Point of Interconnection.

FirstEnergy will provide revenue quality Metering Equipment for a station service power supply at a generation facility if the supply is from the local FirstEnergy distribution system.

The revenue quality Metering Equipment shall be capable of collecting and storing bidirectional billing data. The billing data shall be stored in intervals specified by FirstEnergy, typically fifteen minutes or thirty minutes. The Interconnection Customer must provide FirstEnergy with remote access to the billing data in the Metering Equipment via a dedicated voice-grade analog telephone circuit. The Interconnection Customer shall provide FirstEnergy with contact information for the person or persons responsible for meter programming and Metering Equipment maintenance.

The Interconnection Customer shall consult with FirstEnergy regarding the revenue quality metering system design and provide the following information:

- Facility one line and revenue metering installation drawings (schematics, wiring diagrams, etc.)
- Estimated power flows to and from the facility at all revenue metering points
- Current transformer and voltage transformer specifications, including manufacturer, type, nameplate drawings, and certified accuracy test reports
- Revenue meter specifications including manufacturer, type, model number, and accuracy
- Revenue meter program information including but not limited to billing data recorder channel assignments, recorder pulse weights (Ke), and read-only password for access to interval data by the FirstEnergy billing data collection system (MV-90)
- Revenue meter telephone number
- Revenue meter loss compensation data (if applicable)

The Interconnection Customer shall provide FirstEnergy with prior notification of any modifications at the facility that will affect the revenue meter measurements, including substation reconfigurations and meter program changes.

The revenue metering system at each location shall be tested for accuracy by the Interconnection Customer once every two years. The Interconnection Customer shall give reasonable notice to FirstEnergy of the time when the testing is scheduled so that FirstEnergy may have representatives present. FirstEnergy and the RTO shall have the right to audit the revenue metering equipment and/or related documents. The Interconnection Customer shall be given a reasonable period of time to comply with any requests associated with an audit.