

***Generation Interconnection
Feasibility Study Report***

For

***PJM Generation Interconnection Request
Queue Position W2-083***

Frenchtown-Rosemont 34.5kV

October 2010

Preface

The intent of the feasibility study is to determine a plan, with ballpark cost and construction time estimates, to connect the subject generation to the PJM network at a location specified by the Interconnection Customer. The Interconnection Customer may request the interconnection of generation as a capacity resource or as an energy-only resource. As a requirement for interconnection, the Interconnection Customer may be responsible for the cost of constructing: (1) Direct Connections, which are new facilities and/or facilities upgrades needed to connect the generator to the PJM network, and (2) Network Upgrades, which are facility additions, or upgrades to existing facilities, that are needed to maintain the reliability of the PJM system.

In some instances a generator interconnection may not be responsible for 100% of the identified network upgrade cost because other transmission network uses, e.g. another generation interconnection, may also contribute to the need for the same network reinforcement. The possibility of sharing the reinforcement costs with other projects may be identified in the feasibility study, but the actual allocation will be deferred until the impact study is performed.

The Feasibility Study estimates do not include the feasibility, cost, or time required to obtain property rights and permits for construction of the required facilities. The project developer is responsible for the right of way, real estate, and construction permit issues. For properties currently owned by Transmission Owners, the costs may be included in the study.

General

The Interconnection Customer (IC), has requested to install photo-voltaic solar panels and inverters on a plot of land in Kingwood, New Jersey (Attachment 1). The installed facilities will have a total capability of 20 MW with 7.6 MW of this output being recognized by PJM as capacity. This means that the remaining 12.4 MW will be curtailable should a system reliability constraint occur. The proposed in-service date for this W2-083 Project is October 1, 2011.

Point of Interconnection

W2-083 will interconnect with the Jersey Central Power & Light system at the J712 34kV line between the Frenchtown and Rosemont substations.

PJM Analysis and Network Impacts

Queue project W2-083 was studied as a(n) 20.0MW (7.6MW of which was Capacity) injection into JCPL's system at a tap point along the Frenchtown – Rosemont 34.5kV line. Project W2-083 was evaluated for compliance with reliability criteria for summer peak conditions in 2014. Potential network impacts were as follows:

Generator Deliverability

(Single or N-1 contingencies for the Capacity portion only of the interconnection)

No problems identified.

Multiple Facility Contingency

(Double Circuit Tower Line Contingencies only with full energy output. Stuck Breaker and Bus Fault contingencies will be applied during the Impact Study)

No problems identified.

Contribution to Previously Identified Overloads

(Overloads initially caused by prior Queue positions with additional contribution to overloading by this project. This project may have % allocation of cost responsibility which will be calculated and reported for the Impact Study.)

No problems identified.

New System Reinforcements

(Upgrades required to mitigate reliability criteria violations, i.e. "Network Impacts", initially caused by the addition of this project generation)

None.

Contribution to Previously Identified System Reinforcements

(Overloads initially caused by prior Queue positions with additional contribution to overloading by this project. This project may have a % allocation cost responsibility which will be calculated and reported for the Impact Study)

None.

Short Circuit

(Report Overdutied breakers here)

Not required.

Energy Portion of Interconnection Request

PJM also studied the delivery of the energy portion of the surrounding generation. Any potential problems identified below are likely to result in operational restrictions to the project under study. The developer can proceed with network upgrades to eliminate the operational restriction at their discretion by submitting a Transmission Interconnection request.

Note: Only the most severely overloaded conditions are listed. There is no guarantee of full delivery of energy for this project by fixing only the conditions listed in this section. With a Transmission Interconnection Request, a subsequent analysis will be performed which analyzes all overload conditions associated with the overloaded element(s) identified. As a result of the aggregate energy resources in the area, the following violations were identified.

No problems identified.

First Energy Analysis and Impacts

Power Flow Analysis

A Power Flow study was conducted to determine the reliability impact of the proposed W2-083 Project on the FE Transmission System. This study was completed using a 2014 summer peak load power flow that contains a detailed representation of the Jersey Central transmission networks in the area of the proposed W2-083 Project. The findings and the recommendations from this analysis are based on a contingency review that was performed to identify the facility loadings and/or voltage conditions that violate the Reliability *First*, PJM or FE Planning Criteria and are attributable to this project.

The results of the FE analysis show that there are no network upgrades required for the deliverability of the W2-083 Project generation to the Jersey Central transmission system. There also are no reinforcements defined for previous projects for which this project will have an impact.

Short Circuit and Dynamics Analysis

In accordance with the Interconnection Process, a short circuit analysis will not be conducted by PJM since the W2-083 Project connection is to the Jersey Central 34.5 kV system. Since this Project is solar, the inverter should not contribute to the fault duty of the 34.5 kV breakers on the FE system. “Inverters are generally designed to limit fault currents to 130% or less of rated current. Thus they can usually be disregarded when conducting fault studies.”¹ Therefore no circuit breaker reinforcements will be required.

Note that stability studies will be conducted by the PJM staff should this project proceed to the System Impact Study stage of the Interconnection Process.

System Protection Analysis

An analysis was conducted to assess the impact of the W2-083 Project on the system protection requirements in the area. The results of this review have identified the following minimum requirements:

Under the assumption that the 20 MW W2-083 Project will not supply fault current to the JCP&L system and the ring bus is located within 150 feet of the step-up transformer (for the transformer differential relaying), there will be the following protection upgrades needed for the J712 line exits and step up transformer bays of the three breaker ring bus:

Kingwood 34.5 kV Interconnection Substation (FE Owned)

- (3) 34.5kV 3000A, minimum 30kA (interrupting) rated breaker
- (2) sets of CTs on each side of breaker bushings

¹ EPRI Document TR-111490 “Integration of Distributed Resources in Electric Utility Distribution Systems: Distribution System Behavior Analysis for Suburban Feeder”, published November 1998, page 61

C800 Accuracy Class
2.0 Thermal Factor
1200/5 minimum MR

- (3) 34.5kV PTs (300/175:1)
- (2) SEL-501 Dual-Overcurrent relays
- (1) SEL-311B (Backup line relay to Gilbert)
- (1) SEL-321 (Primary line relay to Gilbert)
- (1) SEL-311L with fiber optic line to Barbertown (W2-016) 3-breaker ring
- (1) SEL-387L with fiber optic line to Barbertown (W2-016) 3-breaker ring
- (1) SEL-311L with fiber optic line to customer owned generating substation
- (1) SEL-387L with fiber optic line to customer owned generating substation
- (3) SATEC Meters
- (1) SEL-2032 for remote relay communication
- (1) Arbiter 1094B GPS clock
- (1) Latching relay for dial-in access (phone line)

Kingwood Generating Substation (Customer Owned)

- (1) 34.5kV PT (300/175:1)
- (1) SEL-501 per 34.5kV breaker
- (1) SATEC Meter
- (1) SEL-311L with fiber optic line to FE owned interconnection substation
- (1) SEL-387L with fiber optic line to FE owned interconnection substation

Barbertown (W2-016) Three Breaker Ring Bus (FE Owned)

- (1) SEL-311L with fiber optic line to Kingwood 3-breaker ring
- (1) SEL-387L with fiber optic line to Kingwood 3-breaker ring

Fault current on the 34.5kV J712 line, 3.85 miles from Frenchtown substation are listed below. These values are for the current system configuration. Any system changes in the area could have a significant impact on these values.

Fault Currents:

Three Phase: 2,365 amperes
Line to Ground: 4,350 amperes

Thevenin Impedances in ohms:

Positive Sequence: $1.607 + j4.288$
Zero Sequence: $4.800 + j15.390$

The Interconnection Customer will also be responsible for installing all project facilities beyond the point of interconnection and at its generation substation in compliance with the FE and regional requirements. This includes breaker protection, unit over/under voltage protection, over/under frequency protection and zero sequence voltage protection as may be required. The

Interconnection Customer will also be responsible for all leasing costs for the circuits that may be required for the communication of data to PJM. FE will not provide a cost estimate for these facilities as a part of this report.

The cost estimate for the required FE system protection facilities is included on Attachment 4.

Metering

The Interconnection Customer will be required to comply with all FE Revenue Metering Requirements for Generation Interconnection Customers. These FE requirements are detailed on Attachment 5 to this report.

Compliance Issues

The proposed interconnection facilities must be designed in accordance with the FirstEnergy “Requirements for Transmission Connected Facilities” located at:

<http://www.pjm.com/planning/design-engineering/to-tech-standards.aspx>

This includes the provision of a reactive power capability sufficient to maintain a composite power delivery for the facility at the interconnection point at a power factor between .95 leading (absorbing 6.6 MVAR) and .90 lagging (producing 9.7 MVAR). If this capability cannot be provided by the solar units, a dynamic device such as a STATCOM or SVC must be installed at the W2-083 Project substation at the Interconnection Customer’s cost.

The Interconnection Customer will also be responsible for following the requirements of the “FirstEnergy Wholesale Generation Interconnection (WGI) Manual” and the “FE Approved Vendors and Contractors” documents which are also located at the above link.

The Interconnection Customer will also be required to meet all PJM, Reliability*First* and NERC reliability criteria and operating procedures for standards compliance. For example, the Developer will need to properly locate and report the over and under-voltage and over and under-frequency system protection elements for its units as well as the submission of the generator model and protection data required to satisfy the PJM and Reliability*First* audits. Failure to comply with these requirements may result in a disconnection of service if the violation is found to compromise the reliability of the FE system.

FE Facility Upgrades and Costs

The results of the FE analysis shows that no planning criteria violations are attributable to the addition of the W2-083 Project for the conditions studied. Therefore the conclusion is that no transmission or distribution reinforcements will be required to provide the requested service.

The following is a summary of the FE facilities that will be required for the direct connection of the W2-083 Generation Project:

1. Construct new Kingwood 34.5 kV Substation in 3 beaker ring bus configuration for the project attachment with one spare position. This includes the design and engineering, acquisition of materials and construction of the required facilities.

(Cost Estimate \$3,336,100)

2. Construct the dead-end 34.5 kV transmission structure and other facilities required for the looped connection of the Frenchtown - Rosemont (J712) 34.5 kV line to the new Kingwood substation.

(Cost Estimate \$178,000)

3. Provide revenue metering current and potential transformers for Sundancer Capital LLC to install at the generation substation. Provide and install the revenue meter.

(Cost Estimate \$20,000)

4. Replace Barbertown 34.5 kV substation relaying on line exit to W2-083 34.5 kV substation.

(Cost Estimate \$95,400)

5. Construct two fiber optic lines (approximately 0.85 miles) for relay communication between Kingwood and Barbertown substations.

(Cost Estimate \$87,800)

All cost data contained in this document should be considered estimated. The applicant will be responsible for the actual cost of construction. FE herein reserves the right to return to any issues in this document and, upon appropriate justification, request additional monies to complete any connections to the transmission system.

Interconnection Customer Requirements

In addition to the FE facilities, the Interconnection Customer will also be responsible for meeting all criteria as specified in the applicable sections of the "FE Requirements for Transmission Connected Facilities" document including:

1. The purchase and installation of the minimum required FE generation interconnection relaying and control facilities. This includes over/under voltage protection, over/under frequency protection, and zero sequence voltage protection relays.
2. The installation of a 34.5 kV interconnection metering instrument transformer, to be supplied by FE.
3. A compliance with the inverter standard UL 1741 and IEEE 1547 in addition to the power quality standards defined by ReliabilityFirst and PJM.
4. A compliance with the FE and PJM generator power factor requirements. Note that the generators may need to absorb reactive power at the point of interconnection during off peak periods to minimize the voltage change should the W2-083 Project units trip off line when at full output.
5. A compliance with the FE and PJM generator voltage control requirements. A voltage schedule to follow will be provided by the FE Transmission Dispatch Center.
6. The execution of a back-up service agreement to serve the customer load supplied from the Kingwood 34.5 kV substation when the units are out-of-service. This assumes the intent of the Interconnection Customer is to net the generation with the station load.
7. Any complaints from other customers (e.g. flicker complaints) will have to be corrected by the Interconnection Customer. Correction may include changing operation, reducing generation, disconnecting the generators from the Jersey Central system, or other measures.
8. The purchase and installation of supervisory control and data acquisition (SCADA) equipment to provide information in a compatible format to the FE Transmission System Control Center. The RTU, the communications channel and all related equipment will be furnished and maintained by the Interconnection Customer. The RTU must communicate with the FirstEnergy EMS via DNP 3.0 protocol.
9. The following status and metering points will be required:
 - a. Interconnection breaker position.
 - b. Generator real and reactive power output measured at the high-side of the generator step-up transformer.
 - c. Generator voltage at the point of interconnection.

10. An installation of two independent high-speed zones of protection to sense and clear faults on the interconnection transformer.

The above requirements are in addition to any metering or other requirements imposed by PJM.

Note that an assumption of this study is that the W2-083 Project generation will automatically be disconnected whenever the local area network is islanded. If this assumption is not correct, a direct transfer trip scheme will need to be implemented for such situations at the Interconnection Customer's cost.

Summary

The connection of the W2-083 Project to the FE transmission system will require no network upgrades. Therefore the Interconnection Customer will only have a cost responsibility for the Direct Connection of the W2-083 Project to the Jersey Central transmission system. As shown on Attachment 4, the estimated cost of these facilities is \$3,717,300.

Based on the extent of the FE direct connection and system upgrades required to support this project, it is estimated that it will take one (1) year from the date of a fully executed Interconnection Construction Service Agreement to complete the upgrades required for the W2-083 Project. This includes the requirement for the Interconnection Customer to make a preliminary payment to FE that funds the first three months of engineering design that is related to the construction of the Direct Connection facilities. It further assumes that the Interconnection Customer will provide the property for the attachment and right-of-way facilities that will be needed. A further assumption is that there will be no environmental issues with any of the new properties associated with this project, that there will be no delays in acquiring the necessary permits for implementing the defined direct connection and network upgrades, and that PJM will allow all 34.5 kV transmission system outages when requested.

Note that the FE findings were made from a conceptual review of this project. A more detailed review of the connection facilities and their cost will be identified in the System Impact Study. Further note that the cost estimate data contained in this document should be considered as only ballpark since it was produced without a detailed engineering review. The applicant will be responsible for the actual cost of construction. FE herein reserves the right to return to any issues in this document and, upon appropriate justification, request additional monies to complete any connections to the transmission system.

Attachment 1
Site Plan

Attachment 2
Aerial View

Attachment 3 Single Line Diagram

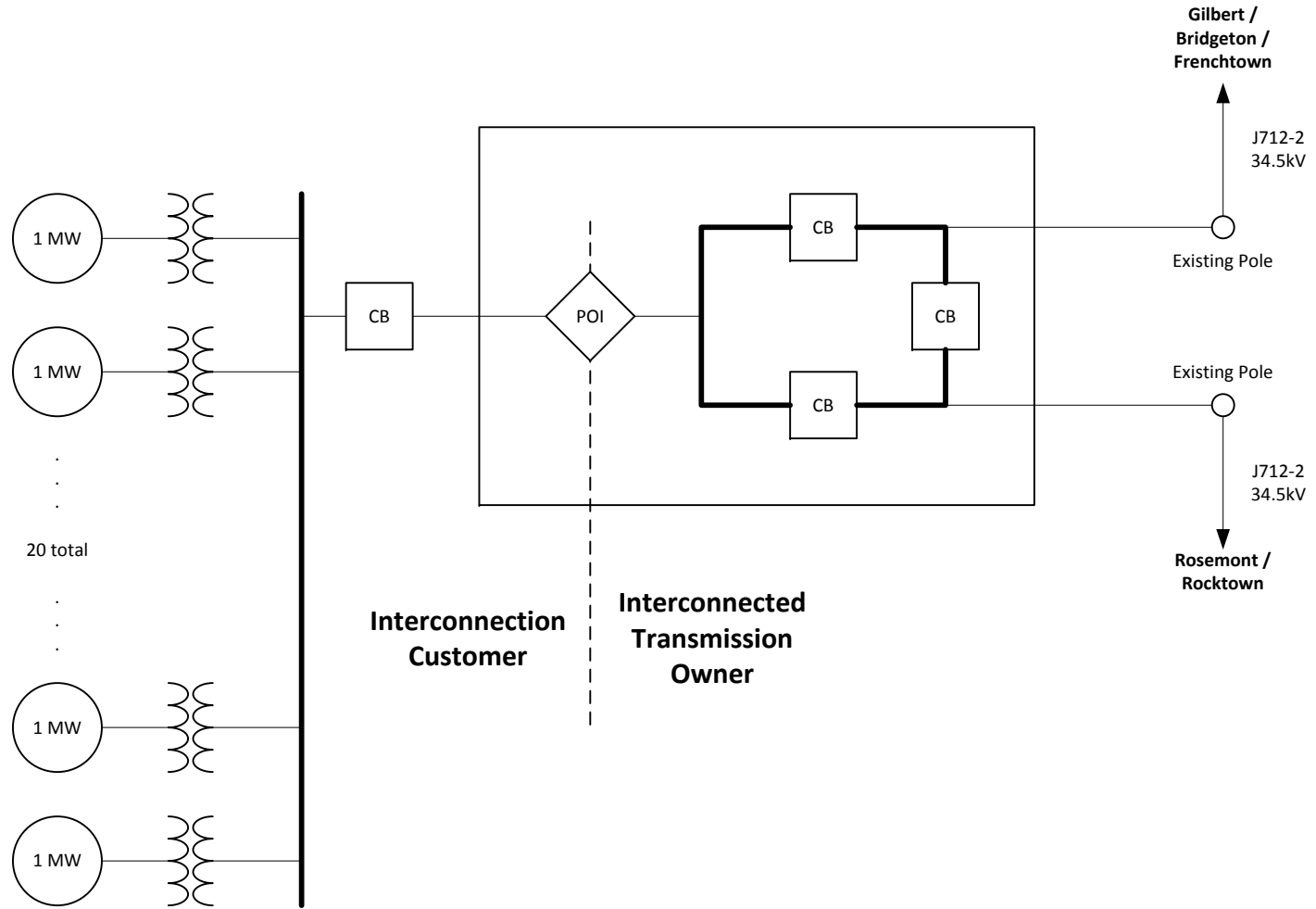

Attachment 4
Cost Estimate

Substation Facility	Direct Connection Substation Facilities	Cost
Kingwood 34.5kV	<ul style="list-style-type: none"> • Construct new 34.5kV substation for 3 breaker ring bus • Include control building for relay panels, SCADA, etc. • Install three 34.5kV circuit breakers – standard 3000 amps, 40kA interrupting capability each • Install six new disconnect switches for circuit breakers – standard 2000 amp each • Install one new disconnect switch for radial generator attachment – standard 2000 amp each • Install 795 ACSR substation conductor or bus bar as needed • Install three line termination structures for the 34.5kV attachment lines • Install drop oops for the three attachment lines – 397.5 ACSR wire • Miscellaneous protection, metering, RTU, SCADA 	\$ 3,336,100
Barbertown 34.5kV	<ul style="list-style-type: none"> • Replace relaying on line exit to Kingwood (W2-083) 34.5kV substation 	\$ 95,400
Kingwood & Barbertown	<ul style="list-style-type: none"> • Construct two fiber optic lines (approximately 0.85 miles) for relay communication between Kingwood and Barbertown substations 	\$ 87,800
Customer's Generation Substation	<ul style="list-style-type: none"> • Provide revenue metering current transformers and voltage transformers for customer installation • Install revenue metering 	\$ 20,000
Total Substation Costs		\$ 3,539,300
Connection Facility	Direct Connection Transmission Facilities	Cost
Gilbert-Frenchtwon-Rocktown Rd (J712) 34.5kV	<ul style="list-style-type: none"> • Construct new double circuit line from Frenchtown-Rosemont (J712-2) 34.5kV to the new Kingwood substation • Install two 34.5kV circuit poles for loop along Frenchtown-Rosemont (J712-2) 34.5kV line • Install line conductor for loop – 397.5 Kcmil 26/7 ACSR Wire or better 	\$ 178,000
Total Transmission Costs		\$ 178,000
Total Direct Connection Upgrade Costs		\$ 3,717,300

Attachment 5

FirstEnergy Revenue Metering Requirements for Generation Facilities Connected 46 kV and Lower

This document addresses the revenue metering requirements for new generation-only facilities connected to FirstEnergy (FE) system voltages 46 kV and lower. This document is not intended for existing retail or wholesale load facilities where behind-the-meter generation is being installed.

The FE operating company (FEOC) shall provide, own, operate, test, and maintain the revenue metering equipment at the Interconnection Customer's (IC) expense. FE reserves the right to review each proposed generation facility design and determine if the IC shall provide, own, operate, test, and maintain the revenue metering equipment at the IC's expense for engineering reasons.

The revenue metering equipment includes, but is not limited to, current transformers, voltage transformers, secondary wires, meter socket, bidirectional revenue meter, and associated devices.

The revenue metering equipment shall be located at the Point of Interconnection (POI) unless otherwise agreed to by FE and the IC. The revenue metering will be compensated for electrical energy losses if it is not located at the POI.

The IC must provide FE with a facility one line, the estimated bi-directional power flow at the revenue metering point, and any loss compensation data.

The IC shall provide and install the mounting structures (or enclosures) and conduits necessary for the metering installation unless otherwise agreed to by the FEOC. The conduit shall be 1-1/2 inch galvanized rigid steel conduit. Flexible galvanized steel (liquid tight) conduit may be used between instrument transformers. The FEOC will install the wiring in the conduit between the instrument transformers and the meter socket.

The IC shall mount the instrument transformers unless otherwise agreed to by the FEOC. The instrument transformers and meter socket shall be installed in a location that is readily accessible to authorized FEOC representatives. If for any reason the meter socket and/or associated devices must be mounted in a weatherproof enclosure, it shall be provided and installed by the IC. The meter socket shall be installed generally within 50 feet of the instrument transformers unless an alternate design has been approved by the FEOC. The meter socket shall be mounted such that the centerline of the meter is approximately five feet above final grade. Where vehicle traffic may interfere with or damage any revenue metering equipment, the IC must install concrete filled steel barrier posts to protect such equipment.

The bidirectional revenue meter provided and installed by the FEOC will record billing data in intervals typically fifteen minutes or thirty minutes. The IC shall provide, at its sole cost and expense, the installation, operation, and maintenance of the communication link required by the FE billing data collection system for access to the meter. The specifications for the typical telephone communication link are as follows:

- Standard voice grade (analog) with dial tone. No digital telephone lines are permitted.
- Two-pair or four-conductor with RJ-11 / Male termination. The FEOC will make final connection to the meter.
- Must be able to receive incoming calls.
- Must be a direct line to the meter with no operator interception or operation required.
- Install the telephone line and associated conduit between the telephone company source and the meter socket or enclosure.
- The telephone line must be tagged with a phone number, including the area code.
- The telephone line must be installed and operational prior to the IC's service being energized.

The IC shall, at its expense, install, own, operate, test, and maintain any metering and telemetry equipment that may be required to provide real-time meter data to FE or PJM.

The FEOC will provide the IC access to bidirectional kWh and kVARh pulses from the FEOC meter at the IC's expense if requested.

The IC shall provide FE with prior notification of any modifications at the facility that could affect the FEOC revenue meter measurements (substation reconfigurations, generator additions, etc).