

***Generation Interconnection
Combined Feasibility/System Impact
Study Report***

For

***PJM Generation Interconnection Request
Queue Position W3-102***

East Carbondale-Lackawanna 69kV

January 2011

Preface

The intent of the Combined Feasibility/System Impact Study is to determine a plan, with approximate cost and construction time estimates, to connect the subject generation interconnection project to the PJM network at a location specified by the Interconnection Customer. As a requirement for interconnection, the Interconnection Customer may be responsible for the cost of constructing: Network Upgrades, which are facility additions, or upgrades to existing facilities, that are needed to maintain the reliability of the PJM system. All facilities required for interconnection of a generation interconnection project must be designed to meet the technical specifications (on PJM web site) for the appropriate transmission owner.

In some instances an Interconnection Customer may not be responsible for 100% of the identified network upgrade cost because other transmission network uses, e.g. another generation interconnection or merchant transmission upgrade, may also contribute to the need for the same network reinforcement. The possibility of sharing the reinforcement costs with other projects may be identified in the Feasibility Study, but the actual allocation, if any, is included in the System Impact Study.

The Study estimates do not include the feasibility, cost, or time required to obtain property rights and permits for construction of the required facilities. The project developer is responsible for the right of way, real estate, and construction permit issues. For properties currently owned by Transmission Owners, the costs associated with them will be addressed when seeking an Interconnection Agreement as outlined below. . Developer will also be responsible for providing and installing metering equipment in compliance with applicable PJM and Transmission Owner standards.

General

GEO Generating, LLC, the Interconnection Customer (IC), has proposed a 15.0 MW (5.7 MW capacity) solar generating facility. The facility will be located in Clinton Township, Wayne County, PA. Queue W3-102 generation interconnection desires commercial operation by May 31st, 2011. **This study does not imply a PPL EU commitment to this in-service date.**

Point of Interconnection

W3-102 will interconnect with the PPL Electric Utilities Corporation transmission system by tapping the Lackawanna-East Carbondale 69 kV line. The W3-102 substation located at grid block 644-N-539, would be connected to the Lackawanna-East Carbondale 69 kV line in the vicinity of grid block 618-N-523 (near the existing East Carbondale 69-12 kV substation) via a new 6 mile 69 kV tap as shown in Figure 1.

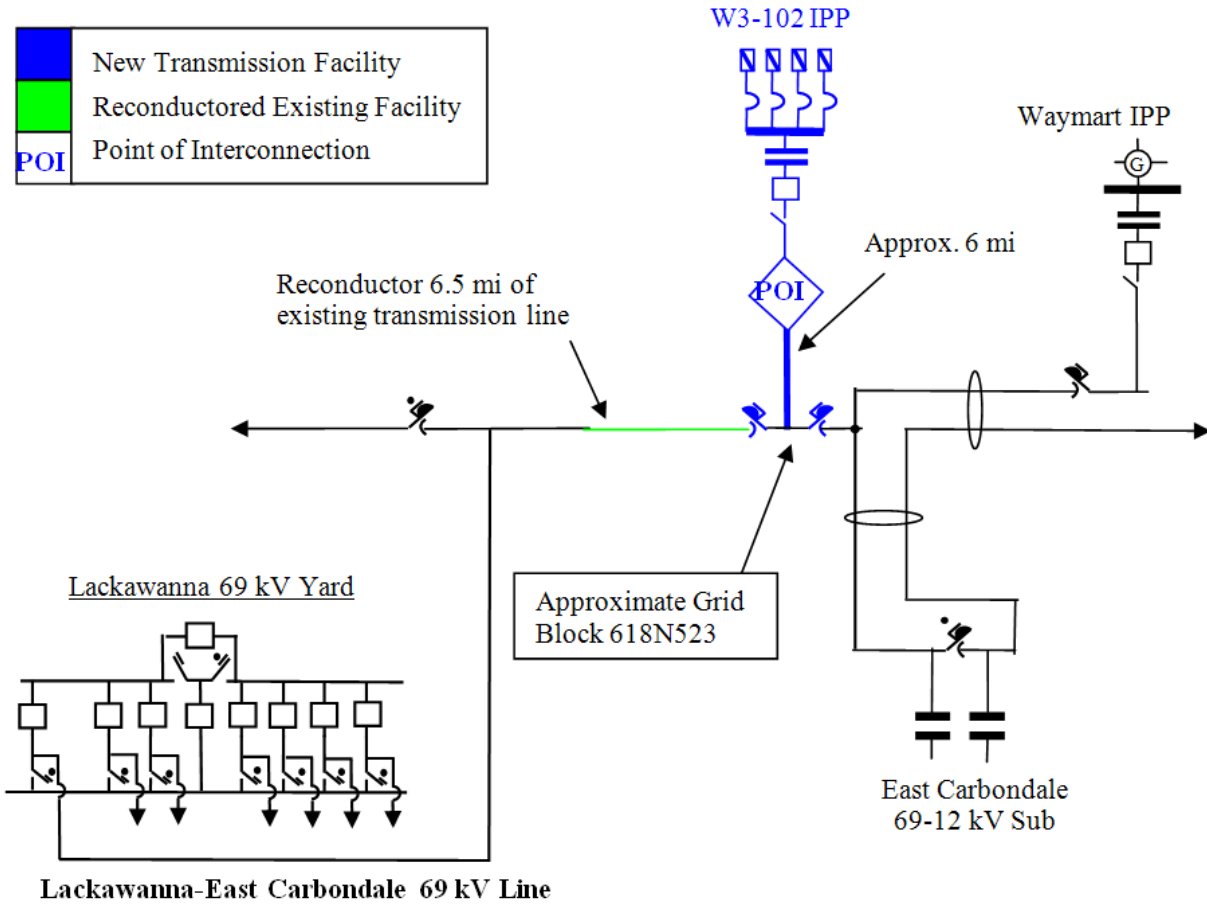

Figure 1

Interconnection Customer Scope of Direct Connection Work

Queue W3-102 Interconnection Customer will be responsible for the construction of all generating station facilities on the W3-102 side of the POI (Point of Interconnection) as shown on Figure 1 on the previous page.

Protection equipment

The Interconnection Customer will need to install suitable protection and control equipment based on PPL EU parallel generation requirements. This includes both Intertie Protective Relaying (IPR) and Point of Contact (POC) relaying. Please refer to the PPL EU web site for the IPR and POC requirements. The website addresses are shown below:

IPR Requirements:

<http://www.pplelectric.com/Business+Partners/Tools+and+Reference+Center/Customer-Owned+Generation/>

POC Requirements:

http://www.pplelectric.com/NR/rdonlyres/B0937C7E-B6E9-40AD-AE8C-ED3C9558E528/0/point_of_contact.pdf

DTT Relaying Requirements

Matching telephone based DTT (Direct Transfer Trip) equipment is required. A telephone based DTT will be required for communications paths between the W3-102 Substation and PPL EU's Lackawanna substation (see 'Telephone Circuit Requirements' section of this Study). However, the telephone line portion would originate from the W3-102 Substation. This is a special dedicated 4 wire analog telephone line, type PRDA.

The DTT scheme will provide a trip signal to the Interconnection Customer for any line fault, or any other condition that will cause the source Lackawanna 69 kV line breaker to trip. The DTT scheme provides a block-closing signal to the breakers at PPL EU source switchyard/substation from the IPP. Automatic reclosing of the PPL EU line breaker will be blocked whenever the Interconnection Customer's 69 kV breaker is closed and the generation is on-line. This signal from the Interconnection Customer will indicate:

- The isolation breaker is open (a breaker 'b' switch) OR
- A contact that will indicate when ANY generator is operating in parallel with the PPL system (contact is OPEN when any generator is in parallel) - this contact will close when ALL generators are OFF line (disconnected from the PPL system).

SCADA Requirements

PPL EU will require the installation of PPL EU approved SCADA equipment that will connect to its existing SCADA system. This connection will be a 4-wire dedicated FDDA-type phone line. PPL EU will provide detailed specifications and design drawings for this equipment.

Telephone Circuit Requirements

PPL EU will require a communication path for DTT, SCADA, and voice. PPL EU anticipates that telephone circuits will be required to establish these paths.

The Interconnection Customer will be responsible to procure the following:

- a) A 4-wire dedicated FDDA-type phone line for SCADA.
- b) A normal dialup telephone line for voice communication. This may be an extension telephone.
- c) A protective relay-grade telephone circuit for the DTT communication requirements, type PRDA. This phone line needs to communicate between the Interconnection Customer's control house and PPL EU's Lackawanna substation.

Phone lines tend to be long lead-time items and must be in place and operational for equipment testing. The Interconnection Customer should investigate with the local phone company the possibility of obtaining this type of service at the Lackawanna-East Carbondale facility. A checklist for ordering DTT and SCADA telephone circuits is available upon the Interconnection Customer's request if they decide to proceed with the interconnection.

All installation, maintenance, and monthly lease or billing charges for communications facilities are the responsibility of the Interconnection Customer.

Dead End Structure Requirement

The Interconnection Customer must install a 69 kV dead-end structure at the point of interconnection. PPL EU will connect its 69 kV transmission line tap to this dead-end structure.

Metering Equipment Installation at the Point of Interconnection

Installation of revenue grade Metering Equipment will be required at the Queue W3-102 Point of Interconnection (POI). PPL EU will design and supply the required metering equipment but all the installation cost would be borne by the developer. All metering equipment must meet applicable PPL EU tariff requirements as well as being compliant with all applicable requirements of the PJM agreements. The equipment should be housed in a control cabinet or similar enclosure and must be accessible to PPL EU metering personnel.

Metering / Telemetry for PJM

Interconnection Customer is also required to provide revenue metering and real-time telemetry data to PJM in compliance with the requirements listed in PJM Manuals M-01 and M-14.

Distribution Service Requirements

The Interconnection Customer must submit a request for electric service through PPL EU's Industrial and Commercial Services (ICS) group if the W3-102 solar park requires back-up electric service at a voltage less than 13 kV. The ICS Help Desk can be reached at 1-888-220-9991. Cost for distribution electric service is NOT included in the PPL scope of work transmission or substation estimates below.

Isolation Breaker Requirement

W3-102 Interconnection Customer will have its own isolation breaker. This breaker can be located on either the high or low side of the Interconnection Customer's transformer. It will be operated by the IPR relay and the DTT and, if it is located on the high side, the POC relaying. This device will NOT be used to synchronize or parallel operating generation to the PPL EU system.

Conversion to 138kV in Future

If there are future changes to the system that would require a change to a 138 kV conversion of the Lackawanna-East Carbondale 69 kV line, the conversion cost of the IPP W3-102 tap would be charged to the generation owner at that time. However there are no plans to convert this line to 138kV operation in the next 10-15 year horizon.

Transmission Owner (PPL EU) Scope of Direct Connection Work

The total estimated cost of Direct Connection Facilities needed to connect Queue W3-102 to the Lackawanna-East Carbondale 69 kV line is **\$9,700,000 (substation cost) + (transmission cost)** (excluding any applicable state or federal taxes). The 69 kV connection estimate is based on the assumptions stated in the following Transmission and Substation Direct Connection Work sections. **This estimate does not include costs for work performed by W3-102 and** will vary depending upon the Queue W3-102 substation location and orientation. Network impacts and associated upgrade requirements are addressed at the end of the report.

The transmission and substation costs given above exclude any applicable state or federal taxes. If at a future date Federal CIAC taxes are deemed necessary by the IRS for this project, both PJM and PPL EU shall be reimbursed by the Interconnection Customer for such taxes.

A further breakdown of the direct connection costs are as follows:

\$ 9,510,000	Transmission Direct Connection Work
\$ 190,000	Substation Direct Connection Work
\$ 9,700,000	Total Direct Connection

Note: Before the Facilities Study stage, the exact location of the Interconnection Substation must be identified by the W3-102 developer in order to refine the cost estimate.

After the PJM three-party Interconnection Service Agreement (ISA) and Interconnection Construction Service Agreement (ICSA) are signed and PPL EU receives written authorization by PJM to begin work, PPL EU will commence the siting, engineering design, material purchase, and construction of facilities identified above. The time required for siting and Right-of-Way acquisition is estimated to be **24 months** if no unforeseen complications arise. The typical time needed to complete the transmission design and construction work is estimated to be approximately **19 months**. All Right-of-Way will need to be acquired prior to the start of construction. The substation work can be completed simultaneously with the 138/69 kV line construction. This translates into a **19 to 24 month** project time frame for the direct connection work.

69 kV Transmission Tap Direct Connection Work

\$ 3,430,000	New 6 mile 138/69 kV transmission tap to W3-102
\$ 3,430,000	Reconductor Lackawanna-East Carbondale 69 kV line for 6.5 miles
\$ 2,668,000	Siting/ROW for new 6 mile 138/69 kV transmission tap to W3-102
\$ 9,510,000	Total Transmission Direct Connection Work

The transmission direct connection work includes:

- Tapping off the existing Lackawanna-East Carbondale 69 kV line in the vicinity of grid 618-N-523 and building a new 6 mile connection using 556 ACSR conductor with ½”

EHS overhead ground wire (OHGW) to a dead-end structure in the new W3-102 customer-owned substation. The tap line will be a 138 kV steel pole design. The estimated cost of the transmission line termination work is included in the above estimate.

- Reconductoring the Lackawanna-East Carbondale 69 kV line for 6.5 miles from Greenfield 69-12 kV substation to the East Carbondale 69-12 kV substation and replace all conductor that has a thermal rating less than that of 556 ACSR (i.e., 336 ACSR).
- The transmission cost estimate includes the cost to site and acquire a 100 ft. right-of-way for an approximate 6 mile 138/69 kV single-circuit transmission tap. The estimate does not include costs to litigate or mitigate extraordinary environmental impacts. **The single-circuit tap will be designed for future 138 kV operation however operated initially at 69 kV therefore requiring PUC certification.** The estimated cost to site and acquire right-of-way for this new line is included in the above estimate.

The lead time required for the transmission line direct connection work is approximately **17 to 19 months** (17 months for the siting/right-of-way work and 19 months for the transmission engineering/construction work, where both can be done concurrently). This estimate assumes that suitable line outages can be scheduled as required to terminate the new tap onto the existing transmission lines. Failure to meet a scheduled line outage may result in project delays. All right-of-way must be acquired prior to construction of the new transmission line.

Alternate Outlet for Generation Operation during PPL EU Maintenance

An alternate outlet for the generation was not requested. W3-102 will not be able to generate into the PPL EU network during maintenance on either the 69 kV line to W3-102 or during certain bus outages at the Lackawanna 230-69 kV regional substation.

Lackawanna 69 kV Substation Direct Connection Work

\$	190,000	Lackawanna 230-69 kV Substation work to accommodate W3-102
\$	190,000	Total Substation Direct Connection Work

To accommodate W3-102, the following upgrades are required at PPL EU's Lackawanna 230-69 kV Substation:

- Install telephone line based Direct Transfer Trip (DTT) system to the IPP
- Modify SCADA for new alarms

This work includes installation of phone line based DTT equipment and control design modifications for the East Carbondale terminal at Lackawanna substation. W3-102 will be required to provide a matching set of DTT equipment at their site. The scheme will provide a trip signal to W3-102 for any line fault, or any other condition that will cause the PPL EU breaker at Lackawanna substation to trip. The DTT scheme provides a block-closing signal to the breaker at

Lackawanna from W3-102. Automatic reclosing of the PPL EU line breaker will be blocked whenever the W3-102 69 kV breaker is closed and W3-102 generation is on-line.

Note: PPL EU has not been able to confirm the impact of the inverters on the system or how multiple inverters are going to interact with each other on the system. Therefore, PPL EU will include the installation of Direct Transfer Trip (DTT) facilities for maximum protection of the transmission line in the Feasibility/Impact Study estimate. PPL EU has been trying to communicate with other utilities that have installed similar solar generation on their system to assist in determining the impact. Unless PPL EU is able to determine DTT is not required, it will be included in the project scope.

Direct Connection Issues

W3-102 Inverter and GSU modeling

Per the W3-102 supplied data, the following was used in modeling the PV generators and GSUs:

W3-102 PV Generators:

30 units, 0.5 MW each (0.5 MVA base), net injected into PPL EU system 15 MW (Given).

GSUs:

Inverter Step-up Transformers: Three 0.28/34.5 kV, 1.0 MVA transformers with 5.5% impedance and X/R of 8 (Given).

Intertie Transformers:

Intertie Step-up Transformer: One 34.5/69 kV, 15 MVA (10 MVA base) transformer with $0.0015+j0.0799$ impedance (Calculated).

The W3-102 Interconnection Customer must provide PPL EU and PJM with the transformer test reports and a model of the inverters once they are available in order to perform a more detailed short circuit analysis.

W3-102 Generator Harmonic and Flicker Requirements

On the 69 kV system, the total harmonic distortion to the fundamental voltage wave from a single customer is limited to 1.5% of nominal. In addition, no individual harmonic component can exceed 1.0% of the fundamental system voltage.

If PPL EU discovers that objectionable harmonics in excess of the stated limits are being injected into the system from W3-102's equipment, the Queue W3-102 Interconnection Customer will be responsible for taking corrective measures to mitigate harmonic currents.

Maximum Allowable Harmonic Voltage Distortion Table (Tariff Rule 32)		
Voltage Level	Distortion Factor (% System Voltage)	Individual Harmonic (% System Voltage)
69 kV through 138 kV	1.5	1

Concerning voltage flicker, the W3-102 customer must limit the severity of their voltage variation to within a level which will not cause objectionable flicker to other customers. A voltage drop greater than 5% at the point of interconnection is generally not acceptable. The

frequency and severity of the voltage variation must be considered when determining whether a customer's equipment is violating PPL EU flicker guidelines. PPL EU uses the General Electric flicker-irritation curve as a guideline to determine if the system is operating within acceptable limits. PPL EU will require corrective actions by the W3-102 customer if their operation causes flicker that exceeds PPL EU guidelines. One such correction could be the installation of static var compensators (SVC) to hold a constant voltage.

W3-102 Inverter Regulation or Reactive Support Requirements

PPL EU preliminary load flow studies have indicated that the W3-102 inverters will maintain the required voltage regulation on the Lackawanna-East Carbondale 69 kV tap bus within its required range.

As specified in Interconnection Service Agreement, Appendix 2, Section 4.7.1.1 of the PJM OATT (Open Access Transmission Tariff), the W3-102 generator shall design its Facility to meet the following power factor requirement:

“For all new wind-powered and other non-synchronous generation facilities, if determined in the system impact study to be required for the safety or reliability of the Transmission System, the Generation Interconnection Customer shall design its Customer Facility with the ability to maintain a composite power delivery at continuous rated power output at a power factor of at least 0.95 leading to 0.95 lagging.”

Preliminary Schedule and Notes / Assumptions

PPL EU will begin the project only after the PJM 3-party Interconnection Service Agreement (ISA) and Interconnection Construction Service Agreement (ICSA) are fully executed and PPL EU receives a written authorization by PJM to commence activities.

Tentatively Scheduled Event	Scheduled Date of Completion
Receive Written Customer Authorization –	1/31/2011
Start Siting Process–	2/1/2011
Right of Way Acquired –	7/31/2012
Receive PUC Approval –	1/31/2013
Start of Engineering –	9/1/2012
Release of Engineering –	6/30/2013
Start of Construction –	10/01/2013
Scheduled In Service Date -	04/30/2014

The estimated PPL EU elapsed time to complete the 69 kV direct connection transmission and substation upgrades is approximately 39 months after the execution of an ICSA.

The schedule for the 69 kV transmission and substation work to accommodate W3-102 would depend on the project start date. The work to accommodate W3-102 will require transmission line outages. PPL EU's outage windows for construction are typically available in the spring and fall of the year. Missing an outage window could result in project delays.

Notes / Assumptions:

- The ISA/ICSA or an Interim Interconnection Service Agreement (IISA) must be signed by the W3-102 Interconnection Customer, PJM, and PPL EU before any PPL EU design and construction activities may commence.
- PPL EU recommends that an Interim ISA be completed during the Facilities Study stage to address critical path items, such as long lead-time purchases and any other compressed project schedule issues.
- Long lead-times for leased telephone lines may be encountered. Therefore, the W3-102 Interconnection Customer should investigate the availability of leased telephone facilities to meet its in-service schedule.
- During construction, if extreme weather conditions or other system safety concerns arise, field construction may need to be rescheduled, which could possibly impact the schedule plan.
- Excepting any operational, governmental and/or environmental regulatory delays, the use of additional resources, such as overtime, premiums for expedited material, and/or contractor labor, may enable PPL EU to decrease this construction period. It is also assumed that all right-of-way and easements are secured without impact on anticipated construction start dates.
- A desktop review of the siting was completed- any line route is likely non-condemnable. Therefore, costs for the right of way are highly speculative. This estimate does not contain cost to condemn or otherwise litigate. Also not included costs to mitigate extraordinary threatened species conflicts, permitting or cultural features impacts.
- Transmission work estimates use an assumption that the line will be built single-circuit using LDE poles with horizontal line post construction.

Network Impacts

The Queue W3-102 project was studied as a 15 MW energy (5.7 MW Capacity) injection into the 69kV Lackawanna-East Carbondale line via a 6 mile transmission tap. The project was evaluated for compliance with reliability criteria for summer peak and light load conditions in 2014. Potential network impacts were as follows:

Generator Deliverability

(Single or N-1 contingencies for the Capacity portion only of the interconnection)

When studying the load 2014 summer peak load flow model, with IPP W3-102 and Waymart IPP each injecting maximum output under normal system conditions, the Greenfield substation to East Carbondale substation portion (336 ACSR) of the Lackawanna-East Carbondale 69 kV line is loaded to 98% of its summer normal thermal value.

Under minimum load conditions (70% of summer peak) with both Waymart IPP and W3-102 injecting their full power output into the transmission system, sections of the Lackawanna-East Carbondale 69 kV transmission line would load up to 104% of its summer normal thermal value.

Under minimum load conditions (50% of summer peak) with both Waymart IPP and W3-102 injecting their full power output into the transmission system, sections of the Lackawanna-East Carbondale 69 kV transmission line would load up to 110% of its summer normal thermal value.

Multiple Facility Contingency

(Double Circuit Tower Line contingencies only with full energy output. Stuck Breaker and Bus Fault contingencies will be applied during the Impact Study)

No violations identified.

Contribution to Previously Identified Overloads

(This project contributes to the following contingency overloads, i.e. "Network Impacts", identified for earlier generation or transmission interconnection projects in the PJM Queue.)

No violations identified.

New System Reinforcements

(Upgrades required to mitigate reliability criteria violations, i.e. "Network Impacts", initially caused by the addition of this project generation.)

Reconductoring the Lackawanna-East Carbondale 69 kV line for 6.5 miles from Greenfield 69-12 kV substation to the East Carbondale 69-12 kV substation and replace all conductor that has a thermal rating less than that of 556 ACSR (i.e., 336 ACSR).

Contribution to Previously Identified System Reinforcements

(Overloads initially caused by prior Queue positions with additional contribution to overloading by this project. This project may have a % allocation cost responsibility which will be calculated and reported for the Impact Study.)

None required.

Short Circuit

None required.

Energy Portion of Interconnection Request

PJM also studied the delivery of the energy portion of the surrounding generation. Any potential problems identified below are likely to result in operational restrictions to the project under study. The developer can proceed with network upgrades to eliminate the operational restriction at their discretion by submitting a Transmission Interconnection request.

Note: Only the most severely overloaded conditions are listed. There is no guarantee of full delivery of energy for this project by fixing only the conditions listed in this section. With a Transmission Interconnection Request, a subsequent analysis will be performed which analyzes all overload conditions associated with the overloaded element(s) identified. As a result of the aggregate energy resources in the area, the following violations were identified.

No violations identified.