

***PJM Generation Interconnection
Queue W4-033
Wilmington 34.5kV
Feasibility/System Impact Study***

678627v2
April 2012

Preface

The intent of this System Impact Study is to determine a plan, with cost and construction time estimates, to connect the subject generation to the PJM network at a location specified by the Interconnection Customer. The Interconnection Customer may request the interconnection of generation as a capacity resource or as an energy-only resource. As a requirement for interconnection, the Interconnection Customer may be responsible for the cost of constructing: (1) Direct Connections, which are new facilities and/or facilities upgrades needed to connect the generator to the PJM network, and (2) Network Upgrades, which are facility additions, or upgrades to existing facilities, that are needed to maintain the reliability of the PJM system.

The PJM Reliability Planning Process utilizes PJM planning criteria, NERC Planning Standards, NERC Regional Council planning criteria, and the individual Transmission Owner FERC filed planning criteria. In all cases, PJM applies the most conservative of all applicable planning criteria when identifying reliability problems and determining the need for system upgrades on the PJM system. The application of the NERC Planning Standards is adapted to the specific needs of the PJM system.

In some instances an interconnection customer may not be responsible for 100% of the identified network upgrade cost because other transmission network uses, e.g. another generation interconnection or merchant transmission upgrade, may also contribute to the need for the same network reinforcement. All facilities required for interconnection of a generation interconnection project must be designed in compliance with the technical specifications (on PJM web site) for the appropriate Transmission Owner.

After the System Impact Study Agreement is executed and prior to execution of the Interconnection Service Agreement, an Interconnection Customer may modify its project to reduce the electrical output (MW) (in the case of a Generation Interconnection Request) of the proposed project by up to the larger of 20 percent of the capability considered in the System Impact Study or 50 MW.

The System Impact Study estimates do not include the feasibility, cost, or time required to obtain property rights and permits for construction of the required facilities. The project developer is responsible for the right of way, real estate, and construction permit issues. For properties currently owned by Transmission Owners, the costs may be included in the study.

General

The Interconnection Customer (IC) is proposing a 10MW (3.8MW Capacity) solar farm to be interconnected to the ComEd transmission system. The proposed in-service date for this project is January 1, 2013 and is currently under review.

Attachment Facilities

The Interconnection Customer is proposing to construct a 10MW (3.8MW Capacity) solar farm to be connected to the Wilmington 34.5kV substation in ComEd (See **Figure #1** below). To accommodate this interconnection, the following will need to be installed: 34kV pole top switch, new transfer trip relays at TDC 409 South Joliet and TSS 149 Wilmington in existing panels, two transfer trip receivers, a panel and SCADA unit on the Interconnection Customer site, and two spans of 34kV T-tap will be installed to create a tap point to interconnect the generator lead. ComEd will provide oversight and support of Interconnect Customer installations and testing. ComEd has estimated it will take approximately 12 months from the time payment is received to complete the work for the interconnection.

The Interconnection Customer is responsible for constructing all of the facilities on the Interconnection Customer's side of the Point of Interconnection.

ComEd Technical Requirements

The Interconnection Customer shall adhere to the following technical requirements to make this interconnection feasible:

- a) The customer step-up transformers should be either delta or ungrounded wye on 34.5kV side
- b) The customer should use 4/0 Bare AL conductor or better to interconnect its generating facility to ComEd network. ComEd is using 4/0 Bare Al conductor for this interconnection.
- c) The ComEd 34kV line is rated at 200kV BIL
- d) Presently, the impedance of 34kV line 0952 is : $Z= 2.212R = j4.35X$
- e) Maximum fault level at the point-of-interconnection is 4100 Amp at 34kV
- f) The customer is required to regulate voltage within 95% - 105% of nominal.
- g) The customer should provide 24/7 access to and operating control of 34kV disconnect switch at the point-of-interconnection.
- h) During emergency or line maintenance, ComEd may temporarily reconfigure the 34KV network. The customer is required to shutdown its generating facility during network reconfiguration. ComEd to notify the customer when necessary.
- i) The power output from the generating facility shall meet the power quality standards per IEEE STD 519. The solar farm shall not cause flicker in excess of established levels.
- j) The Interconnection Customer should adhere to ComEd requirements on relay & protection. These requirements will be shared with the customer during engineering coordination.

Loss Factor Charge:

For this project, W4-033, the Loss Factor was calculated to be 0.83%. Therefore under current ComEd system configuration there would be charges applied to this generator for distribution losses. The Loss Factor is subject to periodic update as system configuration change in the future.

Direct Connection Cost Estimate

ComEd has estimated that the cost estimate for the scope of work listed above will be approximately **\$545,573**.

Cost Estimate Assumptions:

1. Interconnection Customer to install a 34kV circuit breaker at its generator lead.
2. Interconnection Customer is responsible for all costs associated with this interconnection.
3. Interconnection Customer is responsible for engineering, procurement, installation and testing of all equipment, metering and relays on the customer side of Point of Interconnection.
4. Interconnection Customer is responsible for engineering, procurement, installation and testing of 34kV line extension between ComEd and the Point of Interconnection.

Revenue Metering and SCADA Requirements

For PJM: The Interconnection Customer (IC) will install equipment necessary to provide Revenue Metering (KWH, KVARH) and real time data (KW, KVAR) for IC's generating Resource. See PJM Manuals M-01 and M-14D, and PJM Tariff Sections 24.1 and 24.2.

For ComEd: The Interconnection Customer (IC) will install equipment necessary to provide bi-directional Revenue Metering (KWH, KVARH) and real time data (KW, KVAR, circuit breaker status, and 34.5 kV voltage) for IC's generating Resource. See ComEd Applicable Standards available on the PJM website ("TO Standards") – "Exelon Energy Delivery Interconnection Guidelines (Generators Greater than 2MVA and Less Than or Equal to 20 MVA)".

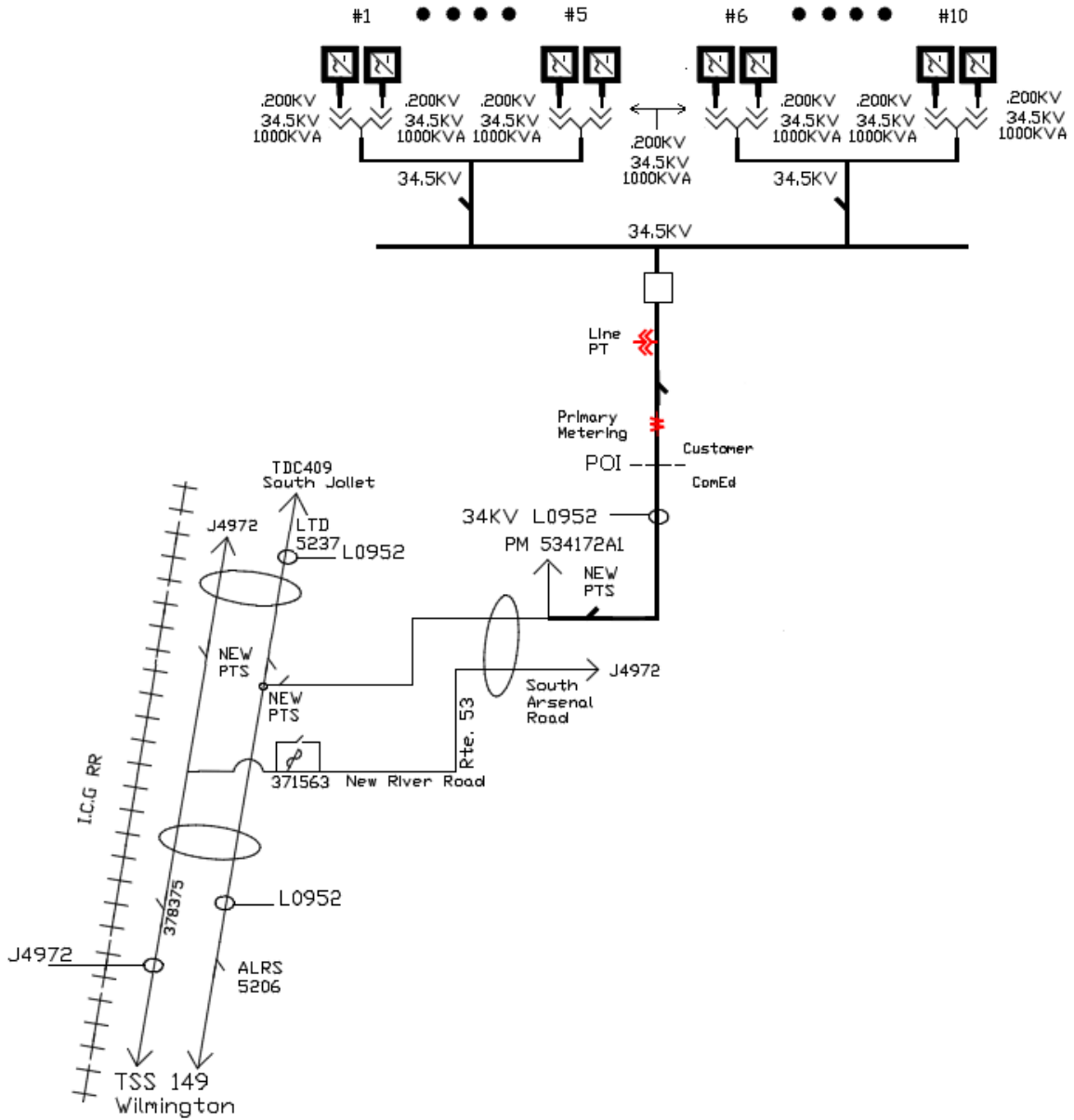

Figure 1. Single Line Diagram

Network Impacts

The Queue Project W4-033 was studied as a 10.0MW (3.8MW Capacity) injection into ComEd's system at the WILMI; 34.5kV substation. Project W4-033 was evaluated for compliance with reliability criteria for summer peak conditions in 2015. Potential network impacts were as follows:

Generator Deliverability

(Single or N-1 contingencies for the Capacity portion only of the interconnection)

No violations were identified.

Multiple Facility Contingency

(Double Circuit Tower Line contingencies were studied for the full energy output. The contingencies of Line with Failed Breaker and Bus Fault will be performed for the Impact Study.)

No violations were identified.

Short Circuit

(Summary of impacted circuit breakers)

ComEd has performed a short circuit study for this project and found that the maximum fault current at the primary meter location is 4100 Amps at 34kV.

Contribution to Previously Identified Overloads

(This project contributes to the following contingency overloads, i.e. "Network Impacts", identified for earlier generation or transmission interconnection projects in the PJM Queue)

No violations were identified.

New System Reinforcements

(Upgrades required to mitigate reliability criteria violations, i.e. Network Impacts, initially cause by the addition of this project generation)

None.

Contribution to Previously Identified System Reinforcements

(Overloads initially caused by prior Queue positions with additional contribution to overloading by this project.)

None.

Steady-State Voltage Requirements

(Summary of VAR requirements based upon the results of the steady-state voltage studies)

None.

Stability and Reactive Power Requirement

(Summary of VAR requirements based upon the results of the dynamic studies.)

Not required.

Delivery of Energy Portion of Interconnection Request

PJM also studied the delivery of the energy portion of this interconnection request. Any problems identified below are likely to result in operational restrictions to the project under study. The developer can proceed with network upgrades to eliminate the operational restriction at their discretion by submitting a Merchant Transmission Interconnection request.

Note: Only the most severely overloaded conditions are listed below. There is no guarantee of full delivery of energy for this project by fixing only the conditions listed in this section. With a Transmission Interconnection Request, a subsequent analysis will be performed which shall study all overload conditions associated with the overloaded element(s) identified.

As a result of the aggregate energy resources in the area, no violations were identified.