

***PJM Generation Interconnection  
Queue W4-086  
Goose Lake 34.5kV  
Feasibility/System Impact Study***

678629v1  
December 2012

## **Preface**

The intent of this System Impact Study is to determine a plan, with cost and construction time estimates, to connect the subject generation to the PJM network at a location specified by the Interconnection Customer. The Interconnection Customer may request the interconnection of generation as a capacity resource or as an energy-only resource. As a requirement for interconnection, the Interconnection Customer may be responsible for the cost of constructing: (1) Direct Connections, which are new facilities and/or facilities upgrades needed to connect the generator to the PJM network, and (2) Network Upgrades, which are facility additions, or upgrades to existing facilities, that are needed to maintain the reliability of the PJM system.

The PJM Reliability Planning Process utilizes PJM planning criteria, NERC Planning Standards, NERC Regional Council planning criteria, and the individual Transmission Owner FERC filed planning criteria. In all cases, PJM applies the most conservative of all applicable planning criteria when identifying reliability problems and determining the need for system upgrades on the PJM system. The application of the NERC Planning Standards is adapted to the specific needs of the PJM system.

In some instances an interconnection customer may not be responsible for 100% of the identified network upgrade cost because other transmission network uses, e.g. another generation interconnection or merchant transmission upgrade, may also contribute to the need for the same network reinforcement. All facilities required for interconnection of a generation interconnection project must be designed in compliance with the technical specifications (on PJM web site) for the appropriate Transmission Owner.

After the System Impact Study Agreement is executed and prior to execution of the Interconnection Service Agreement, an Interconnection Customer may modify its project to reduce the electrical output (MW) (in the case of a Generation Interconnection Request) of the proposed project by up to the larger of 20 percent of the capability considered in the System Impact Study or 50 MW.

The System Impact Study estimates do not include the feasibility, cost, or time required to obtain property rights and permits for construction of the required facilities. The project developer is responsible for the right of way, real estate, and construction permit issues. For properties currently owned by Transmission Owners, the costs may be included in the study.

## **General**

The Interconnection Customer (IC) has an existing landfill gas plant interconnected to the ComEd transmission system.

## **Attachment Facilities**

The Interconnection Customer has a 2.1MW (2.1MW Capacity) landfill gas plant that is connected to the Goose Lake 34.5kV substation in ComEd (See **Figure #1** below).

## **Direct Connection Cost Estimate**

The total preliminary estimate for Direct Connection work performed by ComEd is given in the following table:

<b>Description</b>	<b>Total Cost</b>
Set up scada and metering communications and data mapping	\$10,000
<b>Total</b>	<b>\$10,000</b>

**Table 1. Direct Connection Cost Estimate**

**Figure 1. Single Line Diagram**

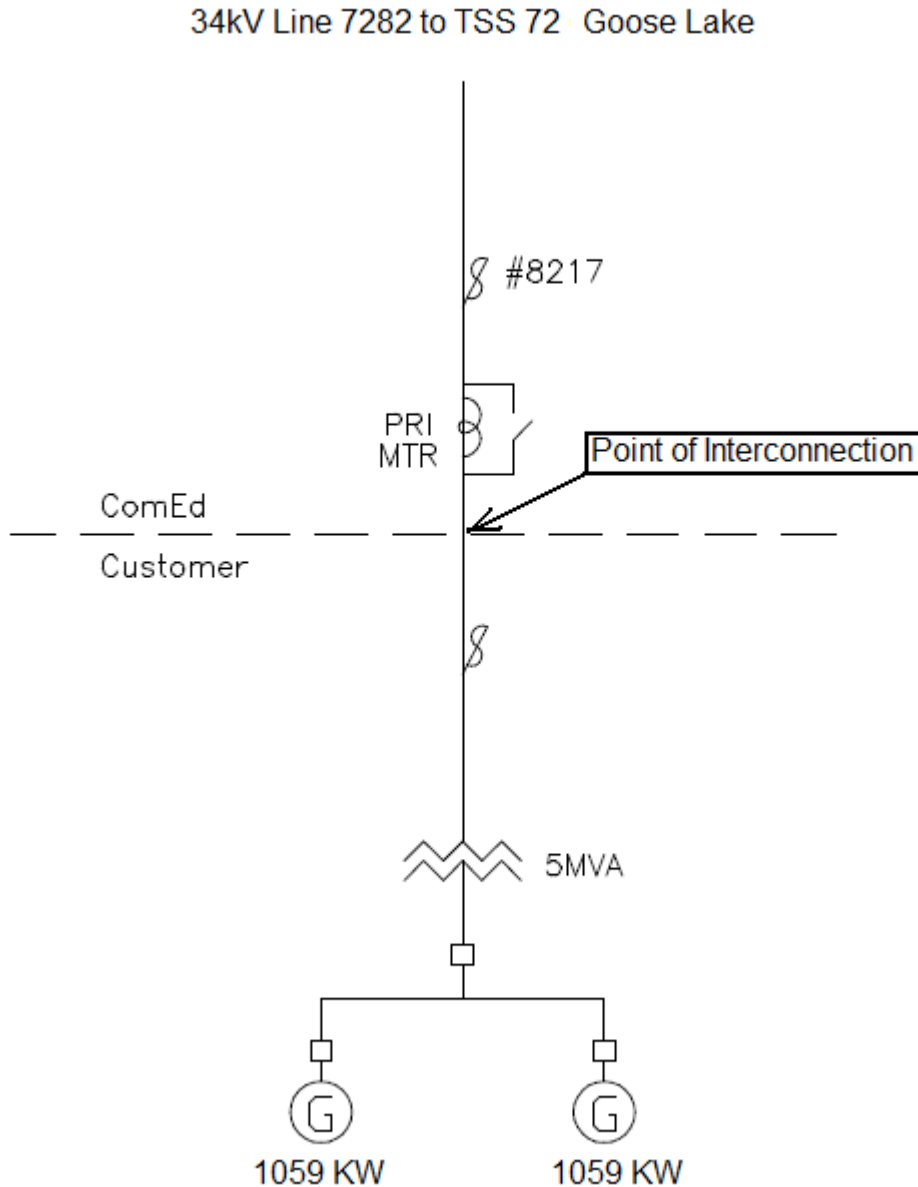

**Revenue Metering and SCADA Requirements**

**For PJM:** The Interconnection Customer (IC) will install equipment necessary to provide Revenue Metering (KWH, KVARH) and real time data (KW, KVAR) for IC's generating Resource. See PJM Manuals M-01 and M-14D, and PJM Tariff Sections 24.1 and 24.2.

**For ComEd:** The Interconnection Customer (IC) will install equipment necessary to provide bi-directional Revenue Metering (KWH, KVARH) and real time data (KW, KVAR, circuit breaker status, and 34.5 kV voltage) for IC's generating Resource. See ComEd Applicable Standards available on the PJM website ("TO Standards") – "Exelon Energy Delivery Interconnection Guidelines (Generators Greater than 2MVA and Less Than or Equal to 20 MVA)".

### **Network Impacts**

The Queue Project W4-086 was studied as a 2.1MW (2.1MW Capacity) injection into ComEd's system at the TSS 72 Goose Lake substation. Project W4-086 was evaluated for compliance with reliability criteria for summer peak conditions in 2015. Potential network impacts were as follows:

#### **Generator Deliverability**

*(Single or N-1 contingencies for the Capacity portion only of the interconnection)*

No violations were identified.

#### **Multiple Facility Contingency**

*(Double Circuit Tower Line contingencies were studied for the full energy output. The contingencies of Line with Failed Breaker and Bus Fault will be performed for the Impact Study.)*

No violations were identified.

#### **Short Circuit**

*(Summary of impacted circuit breakers)*

No violations were identified.

#### **Contribution to Previously Identified Overloads**

*(This project contributes to the following contingency overloads, i.e. "Network Impacts", identified for earlier generation or transmission interconnection projects in the PJM Queue)*

No violations were identified.

#### **New System Reinforcements**

*(Upgrades required to mitigate reliability criteria violations, i.e. Network Impacts, initially cause by the addition of this project generation)*

None.

#### **Contribution to Previously Identified System Reinforcements**

*(Overloads initially caused by prior Queue positions with additional contribution to overloading by this project.)*

None.

**Steady-State Voltage Requirements**

*(Summary of VAR requirements based upon the results of the steady-state voltage studies)*

None.

**Stability and Reactive Power Requirement**

*(Summary of VAR requirements based upon the results of the dynamic studies.)*

Not required.

**Delivery of Energy Portion of Interconnection Request**

*PJM also studied the delivery of the energy portion of this interconnection request. Any problems identified below are likely to result in operational restrictions to the project under study. The developer can proceed with network upgrades to eliminate the operational restriction at their discretion by submitting a Merchant Transmission Interconnection request.*

*Note: Only the most severely overloaded conditions are listed below. There is no guarantee of full delivery of energy for this project by fixing only the conditions listed in this section. With a Transmission Interconnection Request, a subsequent analysis will be performed which shall study all overload conditions associated with the overloaded element(s) identified.*

*As a result of the aggregate energy resources in the area, no violations were identified.*