

***Generation Interconnection
Feasibility Study Report***

For

***PJM Generation Interconnection Request
Queue Position W4-101***

Limecrest-Newton 34.5kV

June 2011

Preface

The intent of the feasibility study is to determine a plan, with ballpark cost and construction time estimates, to connect the subject generation to the PJM network at a location specified by the Interconnection Customer. The Interconnection Customer may request the interconnection of generation as a capacity resource or as an energy-only resource. As a requirement for interconnection, the Interconnection Customer may be responsible for the cost of constructing: (1) Direct Connections, which are new facilities and/or facilities upgrades needed to connect the generator to the PJM network, and (2) Network Upgrades, which are facility additions, or upgrades to existing facilities, that are needed to maintain the reliability of the PJM system.

In some instances a generator interconnection may not be responsible for 100% of the identified network upgrade cost because other transmission network uses, e.g. another generation interconnection, may also contribute to the need for the same network reinforcement. The possibility of sharing the reinforcement costs with other projects may be identified in the feasibility study, but the actual allocation will be deferred until the impact study is performed.

The Feasibility Study estimates do not include the feasibility, cost, or time required to obtain property rights and permits for construction of the required facilities. The project developer is responsible for the right of way, real estate, and construction permit issues. For properties currently owned by Transmission Owners, the costs may be included in the study.

General

The Interconnection Customer (IC), has proposed a solar generating facility located in Lafayette and Andover Townships, New Jersey (Attachment 1). The installed facilities will have a total capability of 20.0 MW with 7.6 MW of this output being recognized by PJM as capacity. This means that the remaining 12.4 MW will be curtailable should a system reliability constraint occur. The proposed in-service date for this project is December 31, 2012. **This study does not imply a First Energy commitment to this in-service date.**

Point of Interconnection

W4-101 will interconnect with the Jersey Central Power & Light system at the 34.5kV line A703-3 between the Limecrest and Newtown substations.

First Energy Analysis and Results

As defined by the Interconnection Customer and shown on Attachment 2, the connection point for the W4-101 Project will be about 2.7 miles northeast of the Newton substation. To accommodate the project connection, a new looped 34.5 kV line will be constructed over an existing Distribution line that will extend from the Newton – Lime Crest (A703-3) section of the Franklin – Newton (A703) 34.5 kV line and go 2.9 miles to the W4-101 Project site. In compliance with the FE Connection Requirements, a new 34.5 kV three breaker ring bus will be constructed at the project site for the project attachment. A conceptual one-line diagram for the new 34.5 kV substation is shown on Attachment 3. While FE will construct, own and operate the new 34.5 kV substation and the facilities required for its attachment to the FE system, the Interconnection Customer will be responsible for acquiring all easements, properties and permits that will be needed, and constructing, owning and operating all facilities on its side of the point of interconnection. Note that in addition to possibly expanding the existing ROW's, approximately 0.3 miles of new ROW will need to be obtained for the loop path at the end. The Interconnection Customer will also be responsible for providing a level graded site for the new 34.5 kV substation and an access road as a prerequisite before work can begin. A summary of the FE facilities required for the W4-101 Project Direct Connection and their cost estimate is shown on Attachment 4.

Power Flow Analysis

A Power Flow study was conducted to determine the reliability impact of the proposed W4-101 Project on the FE Transmission System. This study was completed using a 2012 summer peak load power flow that contains a detailed representation of the Jersey Central transmission networks in the area of the proposed W4-101 Project. Note that the year 2012 was chosen for study rather than 2015 since this is the first summer period when the W Queue solar projects are scheduled for service. The findings and the recommendations from this analysis are based on a contingency review that was performed to identify the facility loadings and/or voltage conditions that violate the Reliability *First*, PJM or FE Planning Criteria and are attributable to this project.

The results of the FE analysis show that there are no network upgrades required for the deliverability of the W4-101 Project generation capacity to the Jersey Central and PJM transmission systems. There also are no reinforcements defined for previous projects for which this project will have an impact. However, voltage criteria violations such as high voltage under light load conditions and high and low voltages caused by swings in MW output of the attached generation may be constraining.

Note that a further conclusion of this study is that it will be mandatory for the W4-101 Project to have a range of dynamic reactive capability that supports its operation from a .95 lead to .90 lag power factor. Without a continuous regulation, the FE studies show that the addition of solar projects can cause voltage swings as their output oscillates with moving clouds and system voltages that can exceed the established limits. Should the Interconnection Customer fail to provide a dynamic reactive capability from the W4-101 Project for any reason once interconnected, the Jersey Central and/or PJM Dispatchers may need to take action to curtail both the energy and capacity portion of its output to prevent a non-compliance with voltage criteria.

Short Circuit and Dynamics Analysis

In accordance with the Interconnection process, a short circuit analysis will not be conducted by PJM since the W4-101 Project connection is to the 34.5 kV system. Therefore, the FE Protection staff conducted a short circuit review of the project connection. An assumption of this study was that solar generation projects will contribute no appreciable fault current to the breakers on the FE transmission system. As defined by EPRI: "Inverters are generally designed to limit fault currents to 130% or less of rated current. Thus they can usually be disregarded when conducting fault studies." Based on this fact, the results of the FE analysis showed that no FE circuit breaker will exceed its interrupting capability with the implementation of the W4-101 Project. Therefore no circuit breaker reinforcements will be required.

Note that stability studies will be conducted by the PJM staff as part of the Impact Study stage of the Interconnection process.

System Protection Analysis

An analysis was conducted to assess the impact of the W4-101 Project on the system protection requirements in the area.

Under the assumption that the W4-101 Project generation will not supply fault current to the Jersey Central transmission system and the ring bus is located within 150 feet of the step-up transformer (for the transformer differential relaying), the following protection upgrades Will be required:

New 34.5 kV Interconnection Substation (FE Owned):

- (3) 34.5kV 3000A, minimum 30kA (interrupting) rated breaker
- (2) sets of CTs on each side of breaker bushings
 - C800 Accuracy Class
 - 2.0 Thermal Factor
 - 2000/5 minimum MR
- (3) sets of 34.5kV PTs (300/175:1)
- (3) SEL-501 Dual-Overcurrent relays
- (2) SEL-311B (Backup line relay to Newton and Franklin)
- (2) SEL-321 (Primary line relay to Newton and Franklin)
- (3) SATEC Meters
- (1) Cybectec SMP 16/SG-PM for remote relay communication
- (1) Arbiter 1094B GPS clock
- (1) Latching relay for dial-in access (phone line)

Warbasse Junction Road Generating Substation (Customer Owned):

- (1) SEL-311L with fiber optic line to FE owned interconnection substation
- (1) SEL-387L with fiber optic line to FE owned interconnection substation

Newton Substation:

Upgrade the KD-10 relays to Schweitzer, cannot get the desired reach for Zone 1 protection.
(1) SEL-311B (Primary line relay to Warbasse Junction Road FE owned sub.)

Fault currents at the proposed point of interconnection are listed below:

	Three Phase	Single Line
Thevanin X/R	3.3724	4.3271
Fault Current (Amps)	7,017	2,711

These values are for the current system configuration. Any system changes in the area could have a significant impact on these values. It will be an Interconnection Customer responsibility to make any protection upgrades required should this occur.

A cost estimate of the FE system protection facilities required for the W4-101 is included on Attachment 4.

Metering

The Interconnection Customer will be required to comply with all FE Revenue Metering Requirements for Generation Interconnection Customers. These FE requirements are detailed on Attachment 5 to this report.

Compliance Issues

The proposed interconnection facilities must be designed in accordance with the FirstEnergy “Requirements for Transmission Connected Facilities” located at:

<http://www.pjm.com/planning/design-engineering/to-tech-standards.aspx>

This includes the provision of a reactive power capability sufficient to maintain a composite power delivery for the facility at the interconnection point at a power factor between .95 leading (absorbing 6.6 MVAR) and .90 lagging (producing 9.7 MVAR). If this capability cannot be provided by the solar units, a dynamic device such as a STATCOM or SVC must be installed at the W4-101 Project substation at the Interconnection Customer’s cost.

The Interconnection Customer will be responsible for following the requirements of the “FirstEnergy Wholesale Generation Interconnection (WGI) Manual” and the “FE Approved Vendors and Contractors” documents which are also located at the above link. In addition, the Interconnection Customer will be required to meet all PJM, ReliabilityFirst and NERC reliability criteria and operating procedures for standards compliance. For example, the Developer will need to properly locate and report the over and under-voltage and over and under-frequency system protection elements for its units as well as the submission of the generator model and protection data required to satisfy the PJM and ReliabilityFirst audits. Failure to comply with these requirements may result in a disconnection of service if the violation is found to compromise the reliability of the FE system.

FE Facility Upgrades and Costs

The results of the FE analysis shows that no planning criteria violations are attributable to the addition of the W4-101 Project for the conditions studied. Therefore the conclusion is that no transmission or distribution reinforcements will be required to provide the requested service.

Network Impacts

Queue project W4-101 was studied as a(n) 20.0 MW (7.6 MW of which was Capacity) injection into JCPL's system at the 50.0% tap between Newton and Lime Crest 34.5 kV line. Project W4-101 was evaluated for compliance with reliability criteria for summer peak conditions in 2014.

Potential transmission network impacts are as follows:

Generator Deliverability

(Single or N-1 contingencies for the Capacity portion only of the interconnection)

No violations identified.

Multiple Facility Contingency

(Double Circuit Tower Line contingencies only with full energy output. Stuck Breaker and Bus Fault contingencies will be applied during the Impact Study)

No violations identified.

Contribution to Previously Identified Overloads

(This project contributes to the following contingency overloads, i.e. "Network Impacts", identified for earlier generation or transmission interconnection projects in the PJM Queue.)

No violations identified.

New System Reinforcements

(Upgrades required to mitigate reliability criteria violations, i.e. "Network Impacts", initially caused by the addition of this project generation.)

None required.

Contribution to Previously Identified System Reinforcements

(Overloads initially caused by prior Queue positions with additional contribution to overloading by this project. This project may have a % allocation cost responsibility which will be calculated and reported for the Impact Study.)

None required.

Short Circuit

(Report over-dutied breakers.)

None required.

Energy Portion of Interconnection Request

PJM also studied the delivery of the energy portion of the surrounding generation. Any potential problems identified below are likely to result in operational restrictions to the project under

study. The developer can proceed with network upgrades to eliminate the operational restriction at their discretion by submitting a Transmission Interconnection request.

Note: Only the most severely overloaded conditions are listed. There is no guarantee of full delivery of energy for this project by fixing only the conditions listed in this section. With a Transmission Interconnection Request, a subsequent analysis will be performed which analyzes all overload conditions associated with the overloaded element(s) identified. As a result of the aggregate energy resources in the area, the following violations were identified.

No violations identified.

Interconnection Customer Requirements

In addition to the FE facilities, the Interconnection Customer will also be responsible for meeting all criteria as specified in the applicable sections of the "FE Requirements for Transmission Connected Facilities" document. Since the W4-101 Project will be connected to the 34.5 kV network, the Interconnection Customer will also be responsible for compliance with the FirstEnergy "Technical Requirements for the Interconnection of Parallel-Operated Generation to the FirstEnergy Distribution System". This includes but is not limited to the following:

1. The purchase and installation of the minimum required FE generation interconnection relaying and control facilities. This includes over/under voltage protection, over/under frequency protection, and zero sequence voltage protection relays.
2. A compliance with the FE and PJM generator power factor and voltage control requirements. Note that the W4-101 Project may need to absorb reactive power at the point of interconnection to minimize the voltage change should the units rapidly reduce their output or trip off line.
3. The execution of a back-up service agreement to serve the customer load supplied from the new 34.5 kV substation when the units are out-of-service. This assumes the intent of the Interconnection Customer is to net the generation with the station load.
4. Any complaints from other customers (e.g. flicker complaints) will have to be corrected by the Interconnection Customer. Correction may include changing operation, reducing generation, disconnecting the generators from the Jersey Central system, or other measures.
5. The purchase and installation of supervisory control and data acquisition (SCADA) equipment to provide information in a compatible format to the FE Transmission System Control Center. The RTU, the communications channel and all related equipment will be furnished and maintained by the Interconnection Customer. The RTU must communicate with the FirstEnergy EMS via DNP 3.0 protocol.
6. The following status and metering points will be required:
 - a. Interconnection breaker position.
 - b. Generator real and reactive power output measured at the high-side of the generator step-up transformer.
 - c. Generator voltage at the point of interconnection.
7. An installation of two independent high-speed zones of protection to sense and clear faults on the interconnection transformer.
8. A compliance with the inverter standard UL1741 and IEEE 1547, "Standard for Interconnecting Distributed resources with Electrical Power Systems", in addition to the power quality standards defined by ReliabilityFirst and PJM.

9. A provision of the necessary generator protection, synchronization controls, and fault detection to initiate a trip to protect the W4-101 Project equipment from faults on the Jersey Central System.
10. A compliance with the PJM Manuals and Operating instructions to have a plant operator on call 24/7 to respond within a minute to reduce the output of W4-101 Project when network constraints occur.
11. The Interconnection Customer will not excavate, construct facilities or locate solar panels under the existing FE transmission facilities or on FE right-of-ways without the express permission of FE.
12. The purchase and installation of the standard voice grade (analog) telephone line and associated conduit between the telephone company source and the meter socket or enclosure.

The above requirements are in addition to any metering or other requirements imposed by PJM.

Note that an assumption of this study is that the W4-101 Project generation will automatically be disconnected whenever the local area network is islanded. If this assumption is not correct, a direct transfer trip scheme will need to be implemented for such situations at the Interconnection Customer's cost.

Summary

The connection of the W4-101 Project to the FE transmission system will require no network upgrades. Therefore the Interconnection Customer will only have a cost responsibility for the Direct Connection of the W4-101 Project to the Jersey Central transmission system. As shown on Attachment 4, the estimated cost of these facilities is \$8,350,100.

Based on the extent of the FE direct connection and system upgrades required to support this project, it is estimated that it will take one (1) year from the date of a fully executed Interconnection Construction Service Agreement to complete the upgrades required for the W4-101 Project. Full payment of the estimated cost of the project will be required upon execution of the Interconnection Service Agreement/Interconnection Construction Service Agreement (ISA/CSA). True up of the actual cost versus estimated cost of the project will be performed by FE at the end of the project. It further assumes that the Interconnection Customer will provide the property for the attachment and right-of-way facilities that will be needed. A further assumption is that there will be no environmental issues with any of the new properties associated with this project, that there will be no delays in acquiring the necessary permits for implementing the defined direct connection and network upgrades, and that all 34.5 kV transmission system outages can be scheduled when needed.

Note that the FE findings were made from a conceptual review of this project. A more detailed review of the connection facilities and their cost will be identified in the System Impact Study. Further note that the cost estimate data contained in this document should be considered as only ballpark since it was produced without a detailed engineering review. The applicant will be responsible for the actual cost of construction. FE herein reserves the right to return to any issues in this document and, upon appropriate justification, request additional monies to complete any connections to the transmission system.

Attachment 1
Site Plan

Attachment 2
Aerial View

Attachment 3 Single Line Diagram

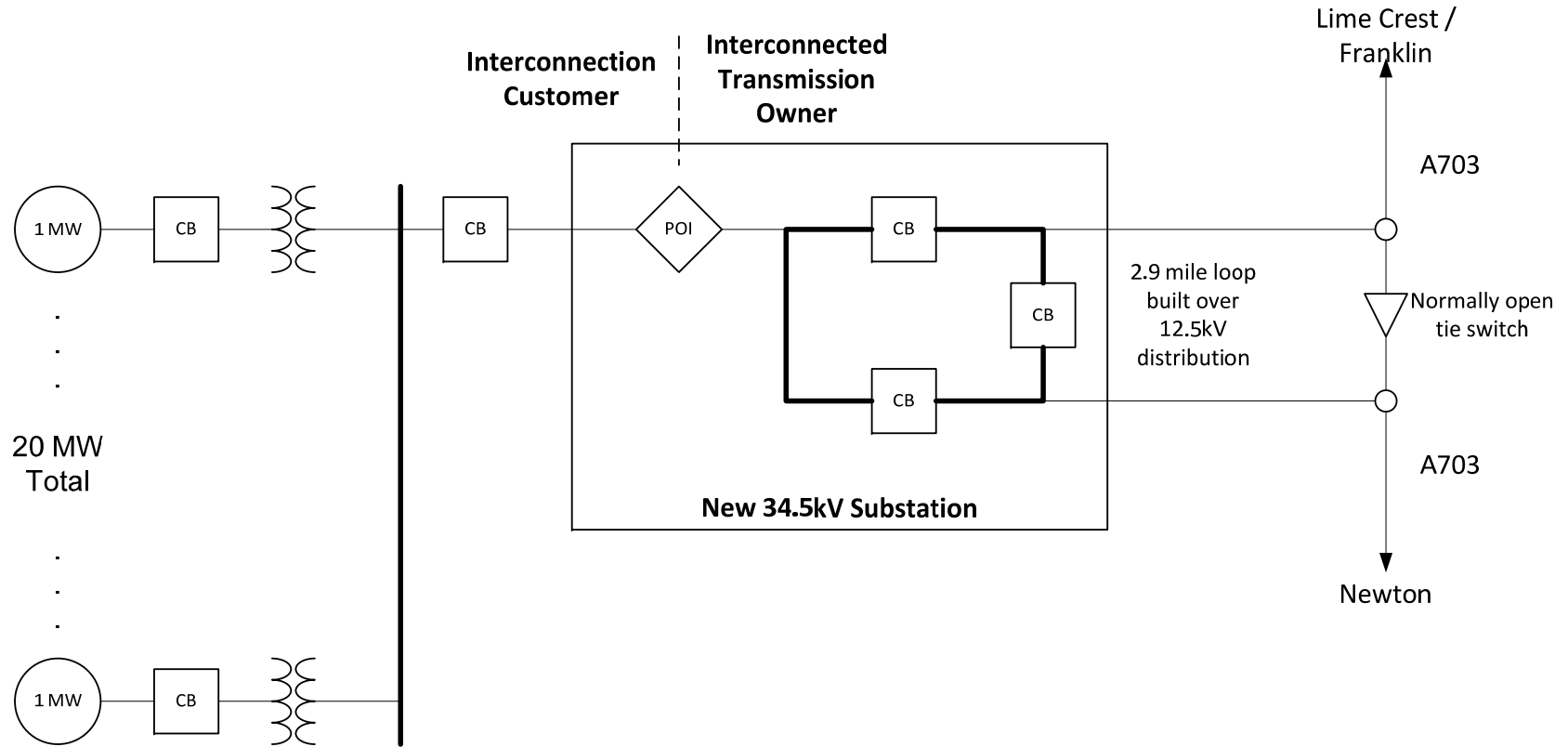

Attachment 4 Estimated Costs

Facility	Connection Facility	Cost
New 34.5kV Substation	<ul style="list-style-type: none"> • Construct New 34.5 kV Substation for 3 Breaker Ring Bus • Include Control Building for Relay Panels, SCADA, etc. • Install Three 34.5 kV Circuit Breakers - Standard 3000 Amp, 40 kA Interrupting Capability each • Install Six New Disconnect Switches for Circuit Breakers- Standard 2000 Amp each • Install One New Disconnect Switch for Radial Generator Attachment - Standard 2000 Amp each • Install 795 ACSR Substation Conductor or Bus-bar as Needed • Install Three Line Termination Structures for the two 34.5 KV Lines and Generator Attachment • Install Drop Loops for the Two Attachment Lines and the Generator - 795 ACSR Wire • Miscellaneous Protection, Metering, RTU, SCADA 	\$ 3,113,700
Newton 34.5kV	<ul style="list-style-type: none"> • Upgrade the KD-10 relays to Schweitzer • Include SEL-311B 	\$ 70,400
Newton-Franklin (A703) 34.5kV	<ul style="list-style-type: none"> • Construct approximately 0.3 miles of new looped overhead 34.5kV line from a point on the A703 34.5kV line (Franklin-Newton), This new line will be build on newly acquired Right-of-Way with 50' wide tree trimming rights. • Construct approximately 2.6 miles of new overbuild overhead 34.5kV looped line. • Will include two loop poles on JC's main line, install 14 new poles on newly acquired Right-of-Way, replacement of 58 existing distribution poles with taller subtransmission poles and overbuild new 34.5kV subtransmission tap line, new switches on both legs from the tap point to the generator, (single blade disconnects included in estimate), install normally open tie switches between the legs of the proposed tap pole, (single blade disconnects included in estimate), two new intermediate poles between the overbuild line and the customer's substation, leads to customer's new termination structures, and all necessary guying, etc. • Transfer the existing distribution facilities to the new transmission structures. • No estimate for Right-of-Way investigation and engineering is included. Developer is responsible for providing new ROW for the new line and verifying or providing valid rights to JCP&L to overbuild the existing distribution lines, both with 50' wide tree trimming rights.. • No environmental review was conducted as part of this cost estimate. If environmental permitting is needed, an additional \$50,000 will be added to estimate 	\$ 5,166,000
Total Estimated Costs		\$ 8,350,100

Attachment 5

FirstEnergy Revenue Metering Requirements For Generation Facilities Connected 46 kV and Lower

This document addresses the revenue metering requirements for new generation-only facilities connected to FirstEnergy (FE) system voltages 46 kV and lower. This document is not intended for existing retail or wholesale load facilities where behind-the-meter generation is being installed.

The FE operating company (FEOC) shall provide, own, operate, test, and maintain the revenue metering equipment at the Interconnection Customer's (IC) expense. FE reserves the right to review each proposed generation facility design and determine if the IC shall provide, own, operate, test, and maintain the revenue metering equipment at the IC's expense for engineering reasons.

The revenue metering equipment includes, but is not limited to, current transformers, voltage transformers, secondary wires, meter socket, bidirectional revenue meter, and associated devices.

The revenue metering equipment shall be located at the Point of Interconnection (POI) unless otherwise agreed to by FE and the IC. The revenue metering will be compensated for electrical energy losses if it is not located at the POI.

The IC must provide FE with a facility one line, the estimated bi-directional power flow at the revenue metering point, and any loss compensation data.

The IC shall provide and install the mounting structures (or enclosures) and conduits necessary for the metering installation unless otherwise agreed to by the FEOC. The conduit shall be 1-1/2 inch galvanized rigid steel conduit. Flexible galvanized steel (liquid tight) conduit may be used between instrument transformers. The FEOC will install the wiring in the conduit between the instrument transformers and the meter socket.

The IC shall mount the instrument transformers unless otherwise agreed to by the FEOC. The instrument transformers and meter socket shall be installed in a location that is readily accessible to authorized FEOC representatives. If for any reason the meter socket and/or associated devices must be mounted in a weatherproof enclosure, it shall be provided and installed by the IC. The meter socket shall be installed generally within 50 feet of the instrument transformers unless an alternate design has been approved by the FEOC. The meter socket shall be mounted such that the centerline of the meter is approximately five feet above final grade. Where vehicle traffic may interfere with or damage any revenue metering equipment, the IC must install concrete filled steel barrier posts to protect such equipment.

The bidirectional revenue meter provided and installed by the FEOC will record billing data in intervals typically fifteen minutes or thirty minutes. The IC shall provide, at its sole cost and expense, the installation, operation, and maintenance of the communication link required by the FE billing data collection system for access to the meter. The specifications for the typical telephone communication link are as follows:

- Standard voice grade (analog) with dial tone. No digital telephone lines are permitted.
- Two-pair or four-conductor with RJ-11 / Male termination. The FEOC will make final connection to the meter.
- Must be able to receive incoming calls.
- Must be a direct line to the meter with no operator interception or operation required.
- Install the telephone line and associated conduit between the telephone company source and the meter socket or enclosure.
- The telephone line must be tagged with a phone number, including the area code.
- The telephone line must be installed and operational prior to the IC's service being energized.

The IC shall, at its expense, install, own, operate, test, and maintain any metering and telemetry equipment that may be required to provide real-time meter data to FE or PJM.

The FEOC will provide the IC access to bidirectional kWh and kVARh pulses from the FEOC meter at the IC's expense if requested.

The IC shall provide FE with prior notification of any modifications at the facility that could affect the FEOC revenue meter measurements (substation reconfigurations, generator additions, etc).