

**PJM Generator Interconnection
X1-080 Poe-Suffolk 115 kV
135 MW Capacity / 135 MW Energy
Feasibility Study Report**

*July 2011
DMS #656482v1*

Introduction

This Feasibility Study has been prepared in accordance with the PJM Open Access Transmission Tariff, §36.2, as well as the Feasibility Study Agreement between Interconnection Customer (IC), and PJM Interconnection, LLC (PJM), Transmission Provider (TP). The Interconnected Transmission Owner (ITO) is Virginia Electric and Power Company. Prince George Electric Cooperative is an affected system operator.

Preface

The intent of this Feasibility Study is to determine a plan, with preliminary cost and construction time estimates, to connect the subject generation interconnection project to the PJM network at a location specified by IC. As a requirement for interconnection, IC may be responsible for the cost of constructing Network Upgrades, which are facility additions, or upgrades to existing facilities, that are needed to maintain the reliability of the PJM and the underlying system. All facilities required for interconnection of a generation interconnection project must be designed to meet ITO technical specifications.

The Feasibility Study estimates do not include the feasibility, cost, or time required to obtain property rights and permits for construction of the required facilities. IC is responsible for its right of way, real estate, and construction permit issues.

General

Queue project X1-080 was studied as a(n) 135 MW (135 MW of which was Capacity) injection into ITO system at the Suffolk 115 kV substation. Project X1-080 was evaluated for compliance with reliability criteria for summer peak conditions in 2015. Two options were evaluated.

Option 1 Network Impacts:

Generator Deliverability

(Single or N-1 contingencies for the Capacity portion only of the interconnection)

No problems identified.

Multiple Facility Contingency

(Double Circuit Tower Line Contingencies only with full energy output. Stuck Breaker and Bus Fault contingencies will be applied during the Impact Study)

No problems identified.

Contribution to Previously Identified Overloads

(Overloads initially caused by prior Queue positions with additional contribution to overloading by this project. This project may have % allocation of cost responsibility which will be calculated and reported for the Impact Study.)

The Fredericksburg 230 kV-Cranes Corner 230 kV 230 kV line (from bus 314137 to bus 314134 ckt 1) loads from 100.35% to 100.57% (DC power flow) of its emergency rating (637 MVA) for the single contingency '8LDYSMTH_8POSSUM_026'. This project contributes approximately 8.35 MW to the thermal violation.

```
CONTINGENCY '8LDYSMTH_8POSSUM_026'  
DISCONNECT BRANCH FROM BUS 314911 TO BUS 314922 CKT 1 /* 500/500KV, AREA 345/345.  
END
```

The section of 230 kV line located between Fredericksburg and Cranes Corner Substation needs to be re-conducted to mitigate the overload condition. The cost of upgrading this 5 mile line is 2.2-\$4.9M and is expected to take six months to complete.

Short Circuit

(Report Overduty breakers here)

No problems identified.

Energy Portion of Interconnection Request

PJM also studied the delivery of the energy portion of the surrounding generation. Any potential problems identified below are likely to result in operational restrictions to the project under study. The IC can proceed with network upgrades to eliminate the operational restriction at their discretion by submitting a Transmission Interconnection request.

Note: Only the most severely overloaded conditions are listed. There is no guarantee of full delivery of energy for this project by fixing only the conditions listed in this section. With a Transmission Interconnection Request, a subsequent analysis will be performed which analyzes all overload conditions associated with the overloaded element(s)

identified. As a result of the aggregate energy resources in the area, the following violations were identified.

No problems identified.

Option 2 Network Impacts:

Generator Deliverability

(Single or N-1 contingencies for the Capacity portion only of the interconnection)

No problems identified.

Multiple Facility Contingency

(Double Circuit Tower Line Contingencies only with full energy output. Stuck Breaker and Bus Fault contingencies will be applied during the Impact Study)

No problems identified.

Contribution to Previously Identified Overloads

(Overloads initially caused by prior Queue positions with additional contribution to overloading by this project. This project may have % allocation of cost responsibility which will be calculated and reported for the Impact Study.)

The Fredericksburg 230 kV-Cranes Corner 230 kV 230 kV line (from bus 314137 to bus 314134 ckt 1) loads from 100.35% to 100.56% (DC power flow) of its emergency rating (637 MVA) for the single contingency '8LDYSMTH_8POSSUM_026'. This project contributes approximately 8.35 MW to the thermal violation.

```
CONTINGENCY '8LDYSMTH_8POSSUM_026'  
DISCONNECT BRANCH FROM BUS 314911 TO BUS 314922 CKT 1 /* 500/500KV, AREA 345/345.  
END
```

The section of 230 kV line located between Fredericksburg and Cranes Corner Substation needs to be re-conducted to mitigate the overload condition. The cost of upgrading this 5 mile line is 2.2-\$4.9M and is expected to take six months to complete.

Short Circuit

(Report Overdutied breakers here)

No problems identified.

Energy Portion of Interconnection Request

PJM also studied the delivery of the energy portion of the surrounding generation. Any potential problems identified below are likely to result in operational restrictions to the project under study. The IC can proceed with network upgrades to eliminate the

operational restriction at their discretion by submitting a Transmission Interconnection request.

Note: Only the most severely overloaded conditions are listed. There is no guarantee of full delivery of energy for this project by fixing only the conditions listed in this section. With a Transmission Interconnection Request, a subsequent analysis will be performed which analyzes all overload conditions associated with the overloaded element(s) identified. As a result of the aggregate energy resources in the area, the following violations were identified.

No problems identified.

ITO Analysis

ITO assessed the impact of the proposed Queue Project X1-080 interconnection as a 135 MW of energy (135 Capacity) on the ITO Transmission System. The system was assessed using the summer 2015 RTEP case provided to ITO by PJM, this 135 MW capacity injection occurred at the New Bohemia Substation. This analysis did include the impacts of the generation capacity for all higher order queue generators within the ITO Transmission System. When performing a generation analysis, ITO's main analysis will be load flow study results under single contingency (both normal and stressed system conditions) and import/export system conditions. ITO criteria considers a transmission facility overloaded if it exceeds 94% of its emergency rating under normal and stressed system conditions. For import/export studies, ITO considers a transmission facility overloaded if it exceeded 100% of its emergency rating. A full listing of ITO's Planning Criteria and interconnection requirements can be found in the ITO's Facility Connection Requirements which are publicly available at: <http://www.dom.com>.

As part of its generation impact analysis ITO routinely evaluates the impact that a proposed new generation resource will have under maximum generation conditions and import/export system conditions. The results of these studies is discussed in more detail below.

Option 1 (135 MW at New Bohemia Line #106)

This option will require IC to develop an agreement with Prince George Electric Cooperative to interconnect and wheel power through their transmission system to the Point of Interconnection on ITO's Transmission System located at the New Bohemia Delivery Point on Line #106. The net capacity and energy delivered to the PJM System will be measured at that location.

- 1) The first being when local generation including the proposed X1-080 Facility is operated at their maximum capability. The result of this study is shown below.

Normal overload of Line #106 (Poe - New Bohemia) 113.5 MVA on a 118 MVA STE Rating (96.5%). This overload will increase as the system load decreases since power flow study is based on peak loading conditions.

- 2) The second being import and export conditions into and out of the ITO System. Any new facility that is interconnected with the ITO System should not significantly decrement FCITC between utilities. The results of these studies can be found in Tables A and B.

Table A: Import Study Results

Import Study Results			
Area	Summer 2015	Summer 2015 with X1-080	Limiting Element
AEP	2000+	2000+	None
APS	2000+	2000+	None
CPL	2000+	2000+	None
PJM	2000+	2000+	None

Table B: Export Study Results

Export Study Results			
Area	Summer 2015	Summer 2015 with X1-080	Limiting Element
AEP	2000+	2000+	None
APS	2000+	2000+	None
CPL	2000+	2000+	None
PJM	2000+	2000+	None

ITO's Planning Criteria indicates a need to have approximately 2000 MW of import and export capability. The

results of these import and export studies are indicate that the proposed generation facility will not impact ITO's import or export capability.

Attachment Facilities:

Primary attachment is with Prince George Electric Cooperative since they own the tap line from ITO's Line #106 to their New Bohemia Delivery Point.

The ITO will need to install metering and associated equipment at the proposed IC's substation compensated to the POI. Estimated cost \$150,000 dollars.

Network Upgrades:

Upgrade the section of Line #106 between Poe - New Bohemia Substations (approximately 2.9 miles) to a rating of at least 160 MVA. Estimated cost \$ 3,000,000 dollars.

Install an islanding scheme between Poe Substation and proposed Interconnection Substation. Estimated cost \$500,000 dollars.

Proposed One-Line

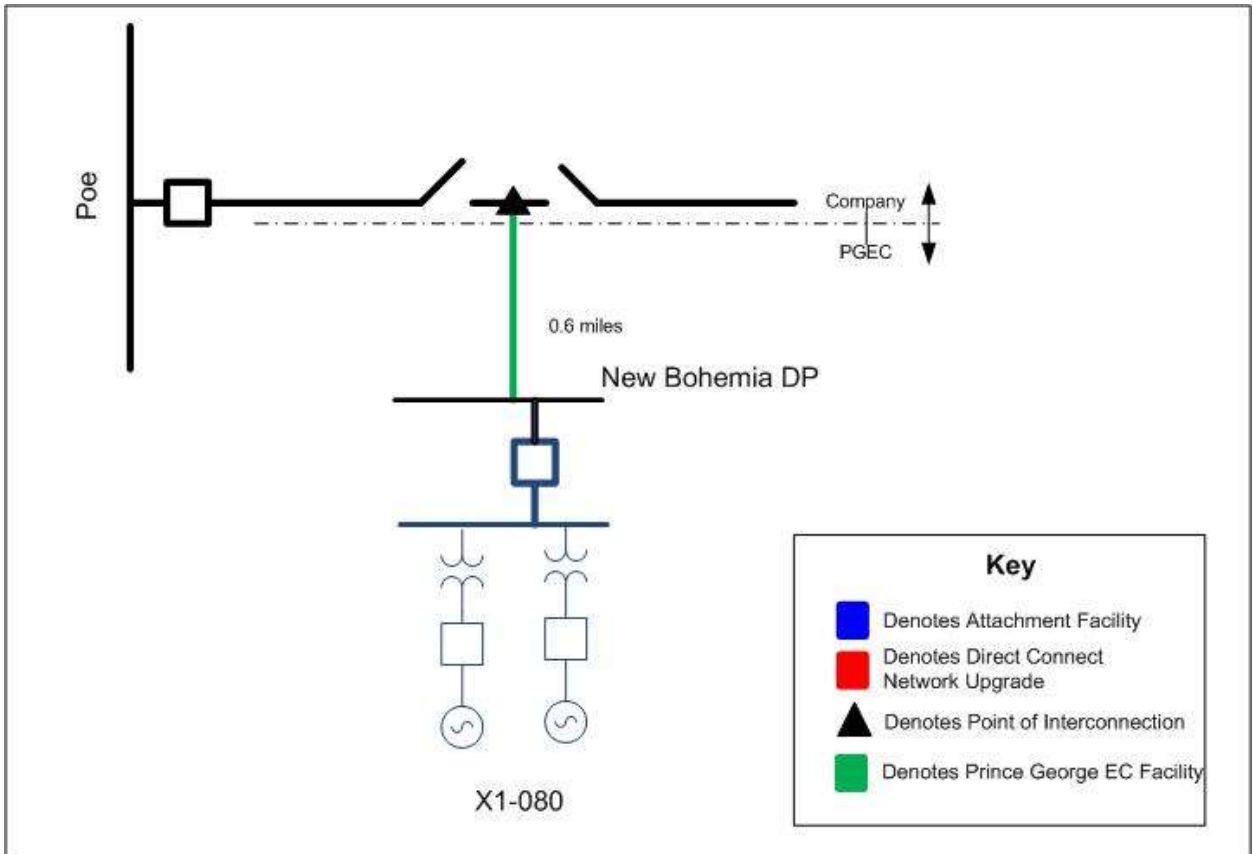

Option Two: 67.5 MW at New Bohemia DP Line #106 and 67.5 MW new Substation located on Line #15(near New Bohemia DP):

This option will still require the IC to develop an agreement with Prince George Electric Cooperative to interconnect and wheel a portion of the power generated by the proposed facility through the PGEC transmission system to the Point of Interconnection on ITO's Transmission System located at the New Bohemia Delivery Point on Line #106. The net capacity and energy delivered to the PJM System will be measured at that location.

1. The first being when local generation including the proposed X1-080 Facility is operated at their maximum capability. The result of this study is shown below.

None

2. The second being import and export conditions into and out of the ITO System. Any new facility that is interconnected with the ITO System should not significantly decrement FCITC between utilities. The results of these studies can be found in Tables A and B.

Table A: Import Study Results

Import Study Results			
Area	Summer 2015	Summer 2015 with X1-080	Limiting Element
AEP	2000+	2000+	None
APS	2000+	2000+	None
CPL	2000+	2000+	None
PJM	2000+	2000+	None

Table B: Export Study Results

Export Study Results			
Area	Summer 2015	Summer 2015 with X1-080	Limiting Element
AEP	2000+	2000+	None
APS	2000+	2000+	None
CPL	2000+	2000+	None
PJM	2000+	2000+	None

ITO's Planning Criteria indicates a need to have approximately 2000 MW of import and export capability. The results of these import and export studies are indicate that the proposed generation facility will not impact ITO's import or export capability.

Attachment Facilities:

One point of attachment is with Prince George Electric Cooperative since they own the tap line from ITO's Line #106 to their New Bohemia Delivery Point.

The ITO will need to install metering and associated equipment at the proposed IC's substation compensated to the POI. Estimated cost \$150,000 dollars.

The second point of attachment is a new interconnection substation tapped off of Line #15.

The ITO will need to install metering and associated equipment at the proposed IC's substation. Estimated cost \$150,000 dollars.

The IC will need to either build or contract with PGEC to build an approximately 1.7 mile long 115 kV line (attachment facility) between ITO's transmission system and their proposed generation site.

Network Upgrades:

Build a three breaker 115 kV ring bus to interconnect the proposed facility with ITO's Transmission System. Since the proposed Attachment Facility is greater than 1 mile a breakers are required per the ITO's Facility Connection Requirements.

Estimate Cost \$2,500,000

Install an islanding scheme between Poe Substation and proposed Interconnection Substation. Estimated cost \$ 700,000 dollars.

Proposed One-Line

