

***PJM Generator Interconnection Request
Queue #X2-040
Wurno (Cloyd's Mountain Sanitary Landfill)
34.5kV
Feasibility/Impact Study***

**667550
October 2011**

X2-040 Wurno (Cloyd's Mountain Sanitary Landfill)

Feasibility/Impact Study Report

Request

Industrial Power Generation Company, LLC (INGENCO) has requested an impact study for a proposed 6.0 MW distributed generation (DG) interconnection with PJM Interconnection, LLC via the Appalachian Power Company (APCO) distribution system. According to the application, data sheets, and one-line provided by INGENCO, the DG installation will initially consist of two generator groups with a total of 4.2 MW (5.3 MVA @ 80% pf with Automated Voltage Regulators (AVR)) with plans to add additional generators in the future that would bring the total plant maximum output to 6.0 MW (7.5 MVA @ 80% pf with AVR). The proposed DG will be installed at the Cloyd's Mountain Sanitary Landfill and will generate electricity by burning methane gas from the landfill. It is the customer's intention to parallel with the utility grid via a primary connection to an existing APCO 34.5kV distribution circuit and to export power to the utility grid. See Figure #1. The system will have the capability to operate 24 hours a day for seven days a week. Pending results of the impact study and appropriate testing, INGENCO plans for the DG to be in-service on June 1, 2012.

The APCO 34.5kV circuit that will connect with the proposed generator is the Dublin Circuit originating from Wurno Substation in Pulaski, VA. Applicable APCO maps will include notes regarding the co-generation installation.

Disclaimer

The contents of this impact study apply only to the unit described in INGENCO's Distributed Generation PJM Interconnection Feasibility Study Agreement X2-040. All modeling is based on a primary metered installation near the Cloyd's Mountain Sanitary Landfill, 7100 Cloyd's Mountain Rd, Dublin, VA.

This review is limited to equipment affecting the APCO system operations. The customer must take all necessary steps to assure compliance with all laws, ordinances, building codes and other applicable regulations. APCO granting approval of the requested connection is not an endorsement of a particular design nor does it assure fitness of the DG to accomplish an intended function.

The customer is expected to understand and comply with IEEE 1547 concerning the DG installation and its requirements for interconnection with the utility grid.

Modeling and Assumptions

It is assumed the customer has received a copy of the Customer Guide To The Interconnection Of Distributed Resources To The American Electric Power (AEP) Distribution System document to guide them through the application process.

The Cloyd's Mountain Sanitary Landfill is served by the Dublin 34.5kV Circuit from the Wurno #1, 138-34.5kV, 30 MVA substation transformer. The Wurno substation has two 138-34.5kV, 30 MVA transformers (#1 and #3) and two 34.5kV distribution buses with a 34.5kV bus tie between them. The bus tie is maintained normally open but operated so that either T1 or T3 can serve both buses at any given time. The Dublin circuit is a radial configured, three-phase, multi-grounded, four-wire, wye system. The nominal primary voltage is 34.5kV L-L, 19.9kV L-G. The landfill presently takes four (4) three-phase (277/480v) and three (3) single phase (120/240v) secondary voltage services from APCO which will continue to remain separate from the co-generation interconnection after the DG installation.

The proposed generator system will initially consist of two parallel groups of six Stamford HCI434E/444E synchronous methane gas generators rated 352 kW (440 KVA @ 80% pf with AVR) each. The DG output will be at 480 volts with an initial maximum output of 4.2 MW (5.28 MVA @ 80% pf with AVR). INGENCO has communicated their plan to gradually grow from the initial 4 MW to a maximum output of 6 MW.

The 480 volt generator output will be stepped up to 34.5kV by two customer owned 2500 kVA, 0.48/34.5kV padmount transformers and will be connected to the existing APCO 34.5kV distribution circuit by customer owned conductor. The customer's facilities should include appropriate recloser protection installed as close to the Point of Common Coupling (PCC) as practical to minimize exposure to existing customers on the Wurno/Dublin circuit. The customer recloser will need to coordinate with APCO's circuit protection scheme (800 amp, G&W Viper, 34.5kV T/S reclosers). The PCC will be an APCO owned overhead primary meter installation located within one span of the existing overhead distribution circuit and connected to a 3-phase, 600 Amp, customer owned, gang operated load break (GOLB) switch. APCO will also install a 3-phase, 600 Amp, GOLB switch on the APCO side of the primary meter installation. The PCC will also be the point of demarcation between APCO and INGENCO owned facilities.

The Wurno/Dublin 34.5 kV circuit voltage is regulated at the substation bus. Data provided by INGENCO indicate that the 480 volt generators will be equipped with appropriate voltage regulation. The DG system will be operated in parallel with the AEP System and the customer intends to export power to the utility grid.

Analysis

The system conditions of concern are:

1. Generator interconnection location and line exposure.
2. Generator fault current contribution.
3. Generator effect on voltage and power flow for the Dublin circuit during peak and light load.
4. Generator effect on power flow for the Wurno substation transformers during peak and light load.

Generator Location and Line Exposure

The DG location for the impact study model is approximately 1000' north of APCO pole #37810357000038 near the end of the Wurno/Dublin 34.5kV distribution circuit. The DG will be connected through the aforementioned customer owned facilities and a primary meter installation located within one span (typically <300') of the APCO circuit. The DG impact was modeled at the 34.5kV PCC.

A primary concern of this DG location is the amount of exposure of the proposed interconnection location to events typical of a multi-phase radial distribution system such as momentary interruptions, permanent interruptions, and voltage sags. The Wurno substation and distribution circuit has been a good reliability performer in the past 12 months (ending June, 2011) relative to the rest of the APCO system. Reliability data indicates that the last 12 months have resulted in the best outage performance for the Dublin circuit over the most recent five year time span, however, recent performance is no guarantee of future performance. This is promoted by the relatively sparse tree cover along the route of the distribution line serving the Cloyd's Mountain Landfill relative to other similar length distribution circuits in APCO; however, the vast open farm lands and elevation of Cloyd's Mountain make the area distribution susceptible to lightning strikes. Significant lightning protection is encouraged on the DG Operator's line protection equipment.

Transmission logs indicate that there have been no recorded momentary or sustained outages on the 138kV line serving the Wurno substation in the past 12 months. Outage records only indicate one sustained outage to the Cloyd's Mountain Landfill on the distribution system in the past 12 months. In addition to the sustained outage, there were two recorded momentary outages (< 5 min) on the Dublin circuit breakers which would have also interrupted the DG operation. APCO does not maintain momentary operation data on the circuit line protective equipment located outside the substation, thus there may have been additional momentary operations that would have affected the proposed DG location. APCO utilizes three phase line recloser installations that operate in single phase mode. Three phase customers are expected to maintain their own loss-of-phase protection. There are a total of four (4) main line recloser installations between the Dublin circuit breaker and the proposed DG location. There are also numerous tap-line devices along the main line which are coordinated with the main line reclosers to provide additional momentary operations to clear temporary faults. In addition to the one sustained outage to the Landfill, there were a total of 53 sustained outages elsewhere on the Dublin circuit in the past 12 months. Of those, approximately 20 outages involved primary line devices involved in dual coordination with upstream devices. Typically, 75% of distribution line faults are temporary in nature, thus statistically there could have been as many as 80 temporary faults that were cleared by line protective devices compared to the 20 sustained outages. It is not known how many of those temporary operations would have also interrupted the proposed DG location and is only shared here in a desire for full disclosure of the potential reliability impact to the proposed DG. As part of this proposal, APCO will set up main line reclosers (replacements) with a sequence coordination scheme that eliminates most operations at that location for faults beyond any tap-line reclosers that might be located down line from the main line reclosers. However, dual coordination between fused tap lines and the main line reclosers will remain in place providing one operation to clear temporary faults occurring beyond the fuse. Tap line fuses can be changed out to line relsers for an additional expense if the DG customer desires, but that cost is not included in the proposed line facilities at the end of this report.

An additional concern that the DG Operator should be aware of is the potential voltage sag caused by faults on 34.5kV distribution circuits, which tend to experience more voltage sag during faults than 12kV circuits. APCO does not have readily available data on the magnitude of voltage sags on the Dublin circuit caused by faults on the circuit, but it is known that industrial customers with sensitive equipment have been susceptible to voltage sags not detectable by most commercial and residential customers. Sensitive customers have even been known to detect voltage sag on the substation bus caused by faults on other circuits connected to the same bus. There is one other,

relatively short, circuit connected to the Wurno #1 34.5kV bus. Given the potential number of momentary operations across the Dublin circuit, nuisance trips caused by temporary voltage sags could be a concern for the DG given the sensitive nature of the IEEE-1547 protection settings.

While past performance has been relatively good, the sheer amount of line length between the transmission source and the proposed DG location presents a significant exposure to the effects of both in-line and tap-line protective equipment operations that could trip the DG off-line considering the sensitive requirements of IEEE-1547. The Wurno substation does not have 138kV line breakers and is connected in-line to a 12.92 mile 138kV line which is protected by high-speed 138kV breakers located at the terminal substations. In addition, there are 12.3 primary line miles and four (4) line recloser installations between the Dublin 34.5kV distribution circuit breaker at Wurno substation and the proposed DG location.

Generator Fault Current Contribution

The maximum available APCO contribution to a three-phase bolted fault (LLL) at APCO pole #37810357000038 near the customer PCC is 1,071 amps symmetrical. The maximum available AEP contribution to a single-phase fault (LG) at the same location is 794 amps symmetrical.

When the maximum proposed INGenco generation is connected to the APCO distribution grid, the total maximum three-phase bolted fault (LLL) at APCO pole #37810357000038 at 34.5 kV is 1,874 amps symmetrical and the total maximum single-phase bolted fault (LG) at the same location is 1,733 amps symmetrical. The maximum fault current contribution of the DG installation near APCO pole #37810357000038 is proportionately significant but still well within the tolerance level of the Wurno/Dublin 34.5kV distribution circuit. These values are subject to change if APCO distribution system enhancements and/or substation enhancements are made in the future. These values are also subject to change if the customer changes their equipment.

The customer responsibilities include providing adequate protection to APCO facilities due to events arising from the operation of the generation under all APCO distribution system operating conditions. The customer is responsible for protecting their own facility under all APCO distribution system operating conditions, whether the generator is connected to the APCO grid or not, including but not limited to:

1. Abnormal voltage or frequency
2. Loss of a single phase of supply
3. Equipment failure
4. Distribution system faults
5. Lightning and switching surges
6. Excessive harmonic voltages
7. Excessive negative sequence voltages
8. Separation from supply
9. Loss of synchronization

INGenco shall provide adequate protection to comply with IEEE 1547 to clear a generation source for all types of faults on the APCO system including any breaker failure events. Adequate protection requires that all fault types are cleared before equipment damage occurs to APCO facilities. Automatic reclosing is applied to APCO transmission and distribution circuits serving the

area. When the APCO source breakers trip, INGENCO shall ensure that their generation equipment is disconnected from APCO facilities in accordance with requirements established in IEEE 1547 prior to automatic reclosure by APCO. INGENCO is solely responsible for the protection of their equipment during automatic reclosing by APCO.

AEP will require communication from the customer site in order to monitor connection status, real power output, reactive power output and voltage at the point of DG connection as stated in section 4.1.6 of IEEE-1547. A standard telephone line such as is available at the Cloyd's Mountain Landfill may be adequate and AEP Telecom can provide assistance to INGENCO on choosing a low cost communications solution when the project moves forward.

Generator Effect on Distribution Circuit Steady State

The generator output has negligible effect on the utility voltage at peak and light load demand levels. The generation effect on power flow does adversely impact some local APCO distribution facilities during both light and peak steady state loading. The last 3.0 miles of distribution line serving the Cloyd's Mountain Landfill consists of 4-#2AA conductor and is operated at 12.47kV through a fused bank of 3-500kVA, 19.9/7.2kV step-down transformers and a bank of 3-35A hydraulic reclosers. The proposed generator output, both initial and maximum capacity, will overload the conductor, the step-down transformers, and 12kV line protection on the existing 3.0 mile Cloyd's Mountain tap at 12kV. The step-down transformer bank on the Cloyd's Mtn. tap will need to be removed and the line converted to 34.5kV operation. The tap line reclosers will need to be replaced with an 800A, three phase, G&W Viper, T/S electronic recloser. In order to upgrade the existing protection scheme, two additional upstream recloser banks (100A and 140A hydraulic) will have to be upgraded as well.

Generator Effect on Distribution Substation Steady State

The Wurno #1 and Wurno #3 transformers at Wurno Substation are lightly loaded during the fall and spring months. Wurno substation is designed with a normally open 34.5kV bus tie between Wurno #1 and Wurno #3 transformers which is used for both maintenance and emergency outages to either transformer. Load levels on the Wurno #1 transformer during light load periods dip to as low as 2.2 MVA. During light load conditions on Wurno #1, the generated load of the DG system will be more than the load on the Dublin 34.5kV circuit and the Wurno #1 34.5kV distribution bus. Given that either transformer can carry either one or both distribution buses, any combination of existing circuit breakers at Wurno station during light load periods could result in reverse power flow onto the transmission system through either Wurno #1 or Wurno #3 transformer. The existing Wurno #1 Load-Tap-Changer (LTC) control does not have reverse power flow capability and given the periodic but eminent reverse power flow through the Wurno #1 substation transformer, the LTC control will need to be replaced with a co-gen capable scheme. The Wurno #3 bus is regulated via single phase bus voltage regulators with controls that presently do not have reverse power flow capability. To maintain operational integrity of the 34.5kV bus tie capability and ensure the same level of substation reliability for APCO customers during transformer contingency and maintenance, the Wurno #3 bus voltage regulator controls will also need to be replaced.

The proposed DG output is not expected to have any adverse affects on AEP 138kV transmission facilities.

Summary

The contents of this impact study apply only to the units described in the PJM interconnection application submitted by INGENCO for a DG interconnection on APCO's Wurno/Dublin 34.5kV distribution circuit which serves the Cloyd's Mountain Sanitary Landfill near Dublin, VA. All modeling is based on assumed generation location near pole number #37810357000038. The cost to repair any damage resulting from system conditions caused by the installation and/or operation of the DG will be borne by the owner of the generation facility. The proposed generation interconnection consists of synchronous methane gas generators with an initial maximum output of 4.2 MW with plans to gradually grow to a maximum output of 6 MW. Customer owned transformation will step the DG output of 480v up to 34.5kV and connect to existing APCO distribution via approximately 1000' of customer installed and owned primary line, GOAB switch, and a three phase electronic recloser protection. APCO will install a GOAB switch and a 34.5kV primary meter installation which will also serve as the PCC. The DG interconnection will be metered at 34.5kV and will include appropriate communications to APCO operations. No adverse system impact on feeder voltage regulation was found as a result of this impact study. It has been determined that the fault current contributions from the proposed generators are within the tolerance levels of the aforementioned APCO distribution circuit. Both the initial and final proposed DG output will require upgrades to the thermal capability of the existing APCO distribution system presently serving the Cloyd's Mountain location.

Facilities

To accommodate both the initial and the final proposed DG output on the APCO distribution system, the following improvements to the Wurno/Dublin 34.5kV distribution circuit will be required:

- Install pole and approx 100' of 4-#2AA to new GOAB pole.
- Install 3-phase, 34.5kV, 600 A, GOAB switch on APCO side of Primary Meter installation.
- Install pole and approx 100' of 4-#2AA to new Primary Meter pole.
- Install 34.5kV, Primary Meter.
- Install communication (some APCO expense may be avoided if phone line provided).
- Remove the 3-167 kVA, 34/12kV step-down transformers on poles 379-540, 541, & 542.
- Replace existing 3-35H reclosers on pole 379-543 with 3ph, G&W Viper T/S recloser.
- Convert line from pole 379-540 to end of line (approx 3 miles) to 34.5kV insulation.
- Convert the following transformer installations to 34.5kV:
 - Pole # 356-6 - 75 kVA Single Phase
 - Pole # 356-8 - (3) 25 kVA 480/277 Y
 - Pole # 356-26 - 10 kVA Single Phase
 - Pole # 356-28 - (3) 25 kVA 480/277 Y
 - Pole # 356-18 - 100 kVA Single Phase
 - Pole # 356-19 - (3) 25 kVA 480/277 Y
 - Pole # 356-38 - (3) 50 kVA 480/277 Y
- Replace existing 3-100DV reclosers on pole 404-168 with a 3ph, G&W Viper T/S recloser.
- Replace existing 3-140DV reclosers on pole 428-5 with a 3ph, G&W Viper T/S recloser.
- Replace existing Wurno #1 LTC control with co-gen capable scheme.
- Replace existing Wurno #3 bus voltage regulator controls with co-gen capable scheme.

Note that the improvements and associated cost provided here do not include any of the work required by INGENCO to extend and connect their generation to the PCC. The preliminary estimated cost of APCO distribution substation and circuit improvements is \$169,900 (circuit) + \$157,300 (substation) = **\$327,200 (Total)**.

Abnormal distribution system events will be addressed on an individual basis through the APCO system operator. Corrective action shall be based on the judgment of the APCO system operator. Possible corrective action can include but is not limited to generation isolation from the distribution system.

This review has been limited to items which may affect the APCO system or to suggestions which may improve operations. The customer must take all necessary steps to assure compliance with all laws, ordinances, building codes and other applicable regulations. Approval of this connection by APCO, when granted, is not an endorsement of a particular design nor does it assure fitness to accomplish an intended function.

Figure #1

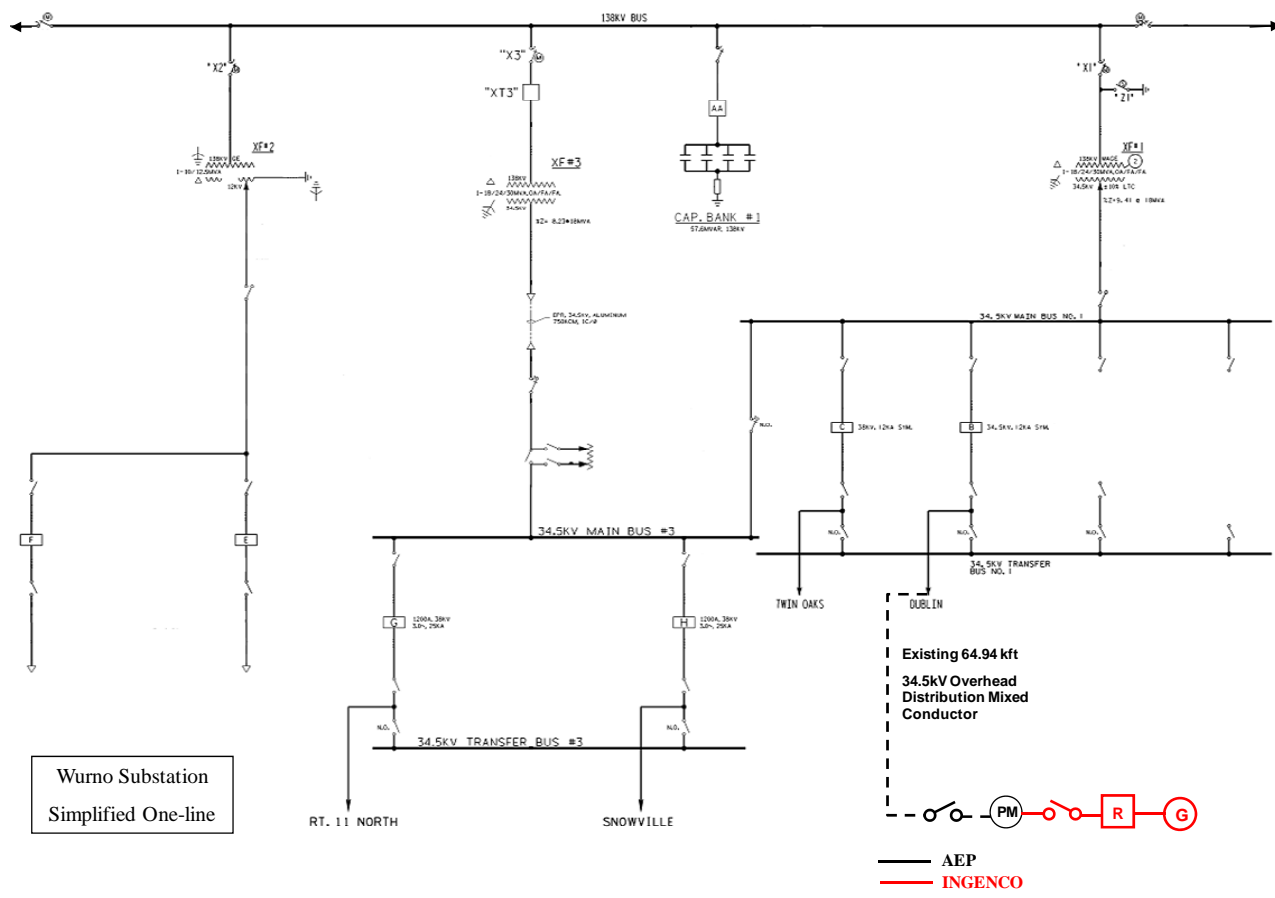

Network Impacts

Queue project X1-040 was studied as a(n) 360.0 MW (46.8 MW of which was Capacity) injection into AEP's system at the 50.0% tap between Collingwood and Forrest G. Hiple Substation 345kV Bus345.0 kV line. Project X1-040 was evaluated for compliance with reliability criteria for summer peak conditions in 2015.

Potential transmission network impacts are as follows:

Generator Deliverability

(Single or N-1 contingencies for the Capacity portion only of the interconnection)

No problems identified

Multiple Facility Contingency

(Double Circuit Tower Line, Line with Failed Breaker and Bus Fault contingencies for the full energy output)

No problems identified

Short Circuit

(Summary form of Cost allocation for breakers will be inserted here if any)

No problems identified

Contribution to Previously Identified Overloads

(This project contributes to the following contingency overloads, i.e. "Network Impacts", identified for earlier generation or transmission interconnection projects in the PJM Queue)

None

New System Reinforcements

(Upgrades required to mitigate reliability criteria violations, i.e. Network Impacts, initially caused by the addition of this project generation)

None

Contribution to Previously Identified System Reinforcements

(Overloads initially caused by prior Queue positions with additional contribution to overloading by this project. This project may have a % allocation cost responsibility which will be calculated and reported for the Impact Study)

(Summary form of Cost allocation for transmission lines and transformers will be inserted here if any)

No problems identified.