

***PJM Generator Interconnection Request
Queue #X2-009 & X2-055
Cedar Grove-Clifton 230kV
Feasibility/Impact Study Report***

**February 2012
#686416
Version 2 February 2012**

X2-009 & X2-055 Cedar Grove-Clifton 230kV

Feasibility/Impact Study

General

H-P Energy Resources has proposed increasing the rating of the two Cedar Grove-Clifton circuits to from 893 to approximately 1093 MVA by reconductoring the circuit with 1590 ACSS wire. Their intention is to upgrade one circuit under the X2-009 queue request and upgrade the second circuit under the X2-055 queue request. H-P Energy Resources also proposed increasing the rating on the Clifton-Athenia portion of the circuit to the same rating.

The intent of the Impact study is to determine system reinforcements and associated costs and construction time estimates required to facilitate the addition of the new generating plant to the transmission system. The reinforcements include the direct connection of the generator to the system and any network upgrades necessary to maintain the reliability of the transmission system.

Direct Connection

To reductor each circuit from Cedar Grove to Clifton (3.325 miles each for a total of 6.65 miles for two circuits), using 1590 ACSS conductor, will cost a total of **\$4,448,750**. The total lead time for this reductoring is 20 weeks. See Figure #1.

To reductor each circuit from Cedar Grove to Athenia (3.825 miles each for a total of 7.65 miles for two circuits), will cost a total of **\$5,163,750**. The total lead time for this reductoring is 26 weeks.

The total cost of reductoring both lines is **\$5,163,500**. The cost of reductoring one of the lines from Cedar Grove to Athenia is half that cost or **\$2,581,875**. The cost of reductoring one line from Cedar Grove to Clifton is **\$2,224,375** and from Clifton to Athenia **\$337,500**.

Figure #1

**X2-009 & X2-055
Cedar Grove-Clifton-Athenia 230kV**

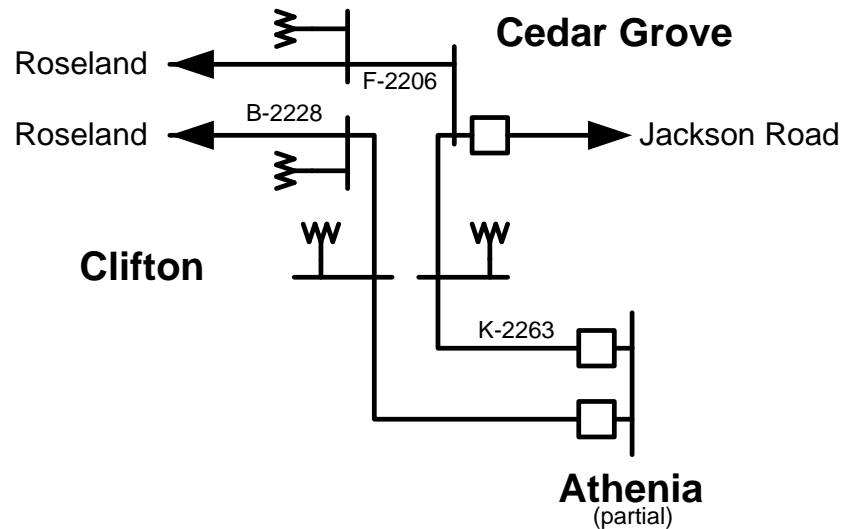

Network Impacts

The Queue Project #X2-009 & X2-055 were studied as a(n) reconductoring of the Cedar Grove-Clifton-Athenia 138kV circuit. Project #X2-009 & X2-055 were evaluated for compliance with reliability criteria for summer peak conditions in 2015. Potential network impacts were as follows:

Generator Deliverability

(Single or N-1 contingencies for the Capacity portion only of the interconnection)

No problems identified

Multiple Facility Contingency

(Double Circuit Tower Line, Line with Failed Breaker and Bus Fault contingencies for the full energy output)

No problems identified

Short Circuit

(Summary form of Cost allocation for breakers will be inserted here if any)

No problems identified.

System Reinforcements

None.

Contribution to Previously Identified System Reinforcements

(Overloads initially caused by prior Queue positions with additional contribution to overloading by this project. This project may have a % allocation cost responsibility which will be calculated and reported for the Impact Study)

None.

***PJM Generator Interconnection Request
Queue #X2-009 & X2-055
Cedar Grove-Clifton 230kV
Feasibility/Impact Study Report***

**February 2012
#686416**

X2-009 & X2-055 Cedar Grove-Clifton 230kV **Feasibility/Impact Study**

General

H-P Energy Resources has proposed increasing the rating of the two Cedar Grove-Clifton circuits to from 893 to approximately 1093 MVA by reconductoring the circuit with 1590 ACSS wire. Their intention is to upgrade one circuit under the X2-009 queue request and upgrade the second circuit under the X2-055 queue request. H-P Energy Resources also proposed increasing the rating on the Clifton-Athenia portion of the circuit to the same rating.

The intent of the Impact study is to determine system reinforcements and associated costs and construction time estimates required to facilitate the addition of the new generating plant to the transmission system. The reinforcements include the direct connection of the generator to the system and any network upgrades necessary to maintain the reliability of the transmission system.

Direct Connection

To reductor each circuit from Cedar Grove to Clifton (3.325 miles each for a total of 6.65 miles for two circuits), using 1590 ACSS conductor, will cost a total of **\$4,448,750**. The total lead time for this reductoring is 20 weeks. See Figure #1.

To reductor each circuit from Cedar Grove to Athenia (3.825 miles each for a total of 7.65 miles for two circuits), will cost a total of **\$5,163,750**. The total lead time for this reductoring is 26 weeks.

The total cost of reductoring both lines is **\$9,612,500**. The cost of reductoring one of the lines from Cedar Grove to Athenia is half that cost or **\$4,806,250**. The cost of reductoring one line from Cedar Grove to Clifton is **\$2,224,375** and from Clifton to Athenia **\$2,881,750**.

Figure #1

**X2-009 & X2-055
Cedar Grove-Clifton-Athenia 230kV**

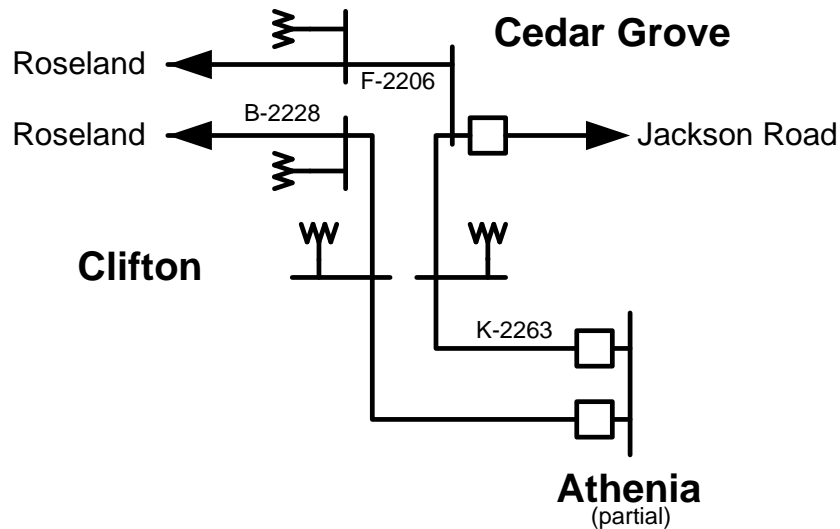

Network Impacts

The Queue Project #X2-009 & X2-055 were studied as a(n) reconductoring of the Cedar Grove-Clifton-Athenia 138kV circuit. Project #X2-009 & X2-055 were evaluated for compliance with reliability criteria for summer peak conditions in 2015. Potential network impacts were as follows:

Generator Deliverability

(Single or N-1 contingencies for the Capacity portion only of the interconnection)

No problems identified

Multiple Facility Contingency

(Double Circuit Tower Line, Line with Failed Breaker and Bus Fault contingencies for the full energy output)

No problems identified

Short Circuit

(Summary form of Cost allocation for breakers will be inserted here if any)

No problems identified.

System Reinforcements

None.

Contribution to Previously Identified System Reinforcements

(Overloads initially caused by prior Queue positions with additional contribution to overloading by this project. This project may have a % allocation cost responsibility which will be calculated and reported for the Impact Study)

None.