

***Generation Interconnection
Combined Feasibility and System Impact
Study Report***

For

***PJM Generation Interconnection Request
Queue Position Y1-080***

Dorchester 12kV

August 2012

Preface

The intent of the Feasibility Study is to determine a plan, with approximate cost and construction time estimates, to connect the subject generation interconnection project to the PJM network at a location specified by the Interconnection Customer. As a requirement for interconnection, the Interconnection Customer may be responsible for the cost of constructing: Network Upgrades, which are facility additions, or upgrades to existing facilities, that are needed to maintain the reliability of the PJM system. All facilities required for interconnection of a generation interconnection project must be designed to meet the technical specifications (on PJM web site) for the appropriate transmission owner.

In some instances an Interconnection Customer may not be responsible for 100% of the identified network upgrade cost because other transmission network uses, e.g. another generation interconnection or merchant transmission upgrade, may also contribute to the need for the same network reinforcement. The possibility of sharing the reinforcement costs with other projects may be identified in the Feasibility Study, but the actual allocation will be deferred until the System Impact Study is performed.

Study estimates do not include the feasibility, cost, or time required to obtain property rights and permits for construction of the required facilities. The project developer may be responsible for the right of way, real estate, and construction permit issues. For properties currently owned by Transmission Owners, the costs may be included in the study.

General

OneEnergy Cambridge, LLC, the Interconnection Customer (IC), has proposed a 3.38 MWE (1.28 MWC; 3.38 MW MFO) solar powered generating facility to be located near Cambridge, Dorchester County, Maryland. PJM evaluated the Y1-080 project's impact on the transmission system by studying it as a 3.38 MW injection into the Delmarva Power and Light (DPL) system at the Airey 69kV substation. The project was evaluated for compliance with reliability criteria for summer peak conditions in 2015. The planned in-service date, as stated in the Attachment N, is November 1, 2013.

Attachment Facilities and local upgrades (if required) along with cost, schedule, and terms and conditions to interconnect Y1-080 will be specified in a separate two party interconnection agreement between the Choptank Electric Cooperative (CEC) and the Interconnection Customer.

Point of Interconnection

Y1-080 will interconnect with the DPL transmission system at the Airey 69/12 kV substation which is adjacent to DPL's West Cambridge-Vienna 69kV circuit. The Airey substation is owned by the Choptank Electric Cooperative (CEC). The physical interconnection for the Y1-080 project is at the CEC 12kV distribution system at the Airey substation (see Attachment 1).

Direct Connection Requirements

Transmission Owner Scope of Work

There is no direct connection scope of work for Delmarva Power and Light Company.

Interconnection Customer Scope of Work

The Interconnection Customer assumes full responsibility for design and construction of all facilities associated with the Y1-080 generating station and the direct connection line on the IC side of the Point of Interconnection.

The IC will be required to install metering and telemetry equipment to provide revenue metering and real-time telemetry data to PJM. The requirements for this equipment are listed in Appendix 2, Section 8 of Attachment O to the PJM Tariff, as well as PJM Manuals 01 and 14D. Protective relaying and metering design and installation must comply with PHI.

Transmission Network Impacts

Potential transmission network impacts are as follows:

Generator Deliverability

*(Single or N-1 contingencies for the **Capacity** portion only of the interconnection)*

None

Multiple Facility Contingency

*(Double Circuit Tower Line, Line with Failed Breaker and, Bus Fault contingencies for the **Full** energy output.*

None

Contribution to Previously Identified Overloads

(This project contributes to the following contingency overloads, i.e. “Network Impacts”, identified for earlier generation or transmission interconnection projects in the PJM Queue)

None

Short Circuit

No issues identified.

Stability Analysis

Not required due to project size.

New System Reinforcements

(Upgrades required to mitigate reliability criteria violations, i.e. “Network Impacts,” initially caused by the addition of this project’s generation)

None

Contribution to Previously Identified System Reinforcements

(Overloads initially caused by prior Queue positions with additional contribution to overloading by this project. The costs identified below represent the total to complete the reinforcement, not necessarily this project’s cost. Actual cost allocations will be deferred until the System Impact Study is performed.)

None

Potential Congestion due to Local Energy Deliverability

(PJM also studied the delivery of the energy portion of the surrounding generation. Any potential problems identified below are likely to result in operational restrictions to the project under study. The developer can proceed with Network Upgrades to eliminate the operational restriction at their discretion by submitting a Transmission Interconnection Request. Note: Only the most severely overloaded conditions are listed below. There is no guarantee of full deliverability for this project by fixing only the conditions listed in this section. With a Transmission Interconnection Request, a subsequent analysis will be performed which analyzes all overload conditions associated with the identified overloaded element(s). As a result of the aggregate energy resources in the area, the following violations were identified:

These are **not** required reliability upgrades.

None

Attachment 1

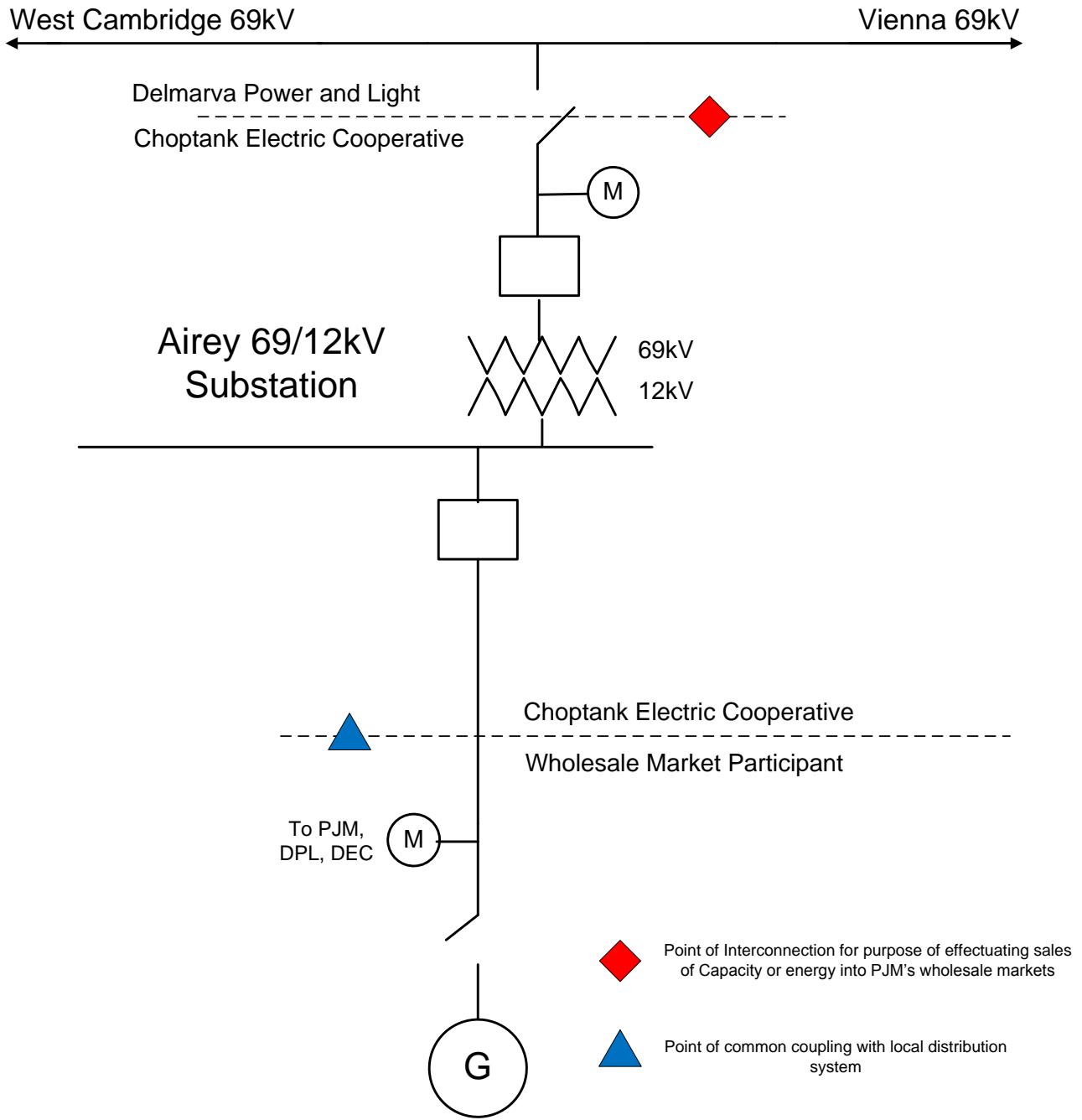

Y1-080